

VALVE OPERATION & SYSTEM DESIGN

**CONTINUING EDUCATION
PROFESSIONAL DEVELOPMENT COURSE**



**Technical
Learning
College**

Printing and Saving Instructions

It is recommended that you download this pdf document and assignment to your computer desktop and open it with Adobe Acrobat DC reader.

Adobe Acrobat DC reader is a free computer software program and you can find it at Adobe Acrobat's website.

You can complete the course by viewing the course on your computer or you can print it out. This course booklet does not have the assignment (the test). Please visit our website and download the assignment (the test).

Printing Instructions: Once you have purchased the program, we will give you permission to print this document. If you are going to print this document, it was designed to be printed double-sided or duplexed but can be printed single-sided.

You can obtain a printed version from TLC for an additional \$129.95 plus shipping charges.

Internet Link to Assignment...

<http://www.abctlc.com/downloads/PDF/ValveOperationandSystemDesignASSIGNMENT.pdf>

State Approval Listing Link, check to see if your State accepts or has pre-approved this course. Not all States are listed. Not all courses are listed. Do not solely trust our list for it may be outdated. It is your sole responsibility to ensure this course is accepted for credit. No refunds.

Professional Engineers, most states will accept our courses for credit but we do not official list the States or Agencies.

State Approval Listing URL...

<http://www.abctlc.com/downloads/PDF/CEU%20State%20Approvals.pdf>

All downloads are electronically tracked and monitored for security purposes.



Some States and many employers require the final exam to be proctored.

Do not solely depend on TLC's Approval list for it may be outdated.

A second certificate of completion for a second State Agency \$50 processing fee.

Most of our students prefer to do the assignment in Word and e-mail or fax the assignment back to us. We also teach this course in a conventional hands-on class. Call us and schedule a class today.

Responsibility

This course contains EPA's federal rule requirements. Please be aware that each state implements drinking water/wastewater/safety regulations that may be more stringent than EPA's or OSHA's regulations. Check with your state environmental agency for more information. You are solely responsible in ensuring that you abide with your jurisdiction or agency's rules and regulations.

Copyright Notice

1999-2020 Technical Learning College (TLC) No part of this work may be reproduced or distributed in any form or by any means without TLC's prior written approval. Permission has been sought for all images and text where we believe copyright exists and where the copyright holder is traceable and contactable. Other materials including text and artwork are in the public domain or fair use (the state of belonging or being available to the public as a whole, and therefore not subject to copyright.) All material that is not credited or acknowledged or referenced in the rear of this course is the copyright of Technical Learning College. All other unacknowledged references are in the Water/ Wastewater Sampling and Water Chemistry Courses. Most unaccredited photographs have been taken by TLC instructors or TLC students. All written, graphic, photographic or other material is provided for educational information only. We will be pleased to hear from any copyright holder and will make good on your work if any unintentional copyright infringements were made as soon as these issues are brought to the editor's attention. This educational training course and assignment is intended for educational purposes only. Every possible effort was made to ensure that all information provided in this course is accurate. Therefore, Technical Learning College accepts no responsibility or liability whatsoever for the application or misuse of any information included herein.

Requests for acknowledgements or permission to make copies shall be made to the following address: TLC, P.O. Box 3060, Chino Valley, AZ 86323

Information in this document is subject to change without notice. TLC is not liable for errors or omissions appearing in this document.

Contributing Editors

James L. Six Received a Bachelor of Science Degree in Civil Engineering from the University of Akron in June of 1976, Registered Professional Engineer in the State of Ohio, Number 45031 (Retired), Class IV Water Supply Operator issued by Ohio EPA, Number WS4-1012914-08, Class II Wastewater Collection System Operator issued by Ohio EPA, Number WC2-1012914-94

Joseph Camerata has a BS in Management with honors (magna cum laude). He retired as a Chemist in 2006 having worked in the field of chemical, environmental, and industrial hygiene sampling and analysis for 40 years.

James Bevan, Water Quality Inspector S.M.E. Twenty years of experience in the environmental field dealing with all aspects of water regulations on the federal, state, and local levels. Teacher and Proctor in Charge for Backflow Certification Testing at the ASETT Center in Tucson for the past 15 years and possess an Arizona Community College, Special Teaching Certificate in Environmental Studies.

Dr. Pete Greer S.M.E., Retired biology instructor, chemistry and biological review.

Jack White, Environmental, Health, Safety expert, City of Phoenix. Art Credits.

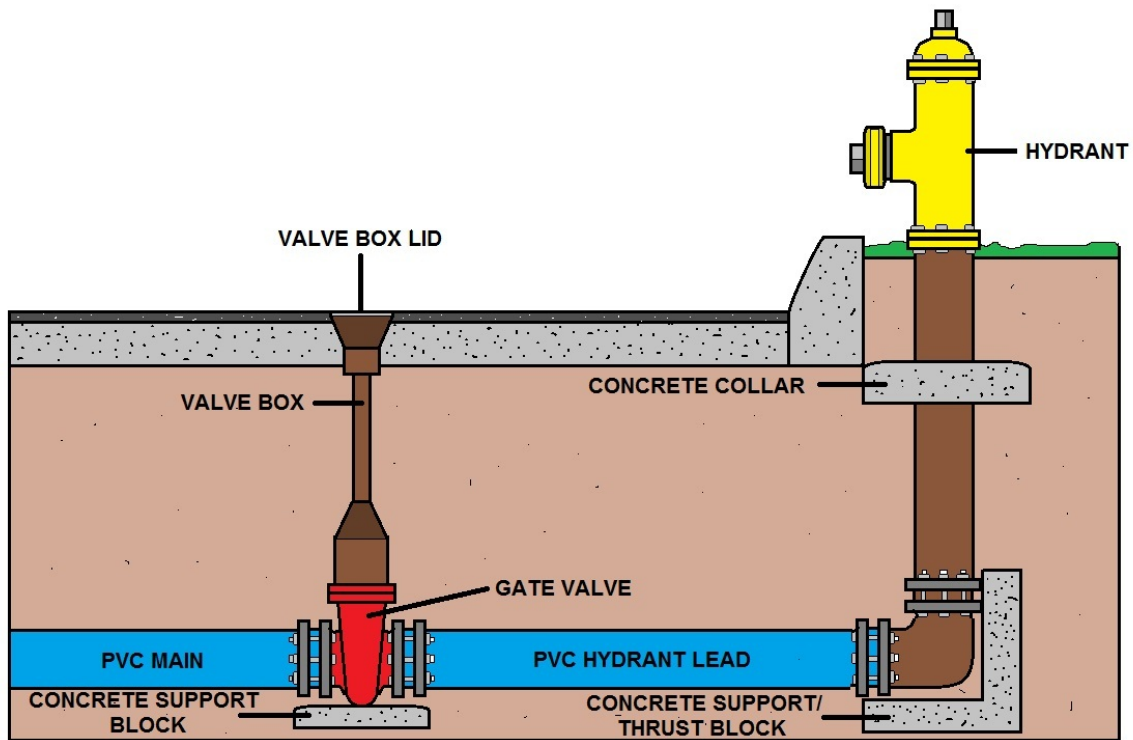

PROPER FIRE HYDRANT AND ISOLATING GATE VALVE INSTALLATION

Important Information about this Manual

This manual has been prepared to educate operators in the general education of valves, valve system design, valve operation, and hydraulic principles including basic mechanical training and different valve related applications. For most students, the study of valving and hydraulics is quite large, requiring a major effort to bring it under control.

This manual should not be used as a guidance document for employees who are involved with cross-connection control. It is not designed to meet the requirements of the United States Environmental Protection Agency (**EPA**) or the Department of Labor-Occupational Safety and Health Administration (**OSHA**) or your state environmental or health agency. Technical Learning College or Technical Learning Consultants, Inc. make no warranty, guarantee or representation as to the absolute correctness or appropriateness of the information in this manual and assumes no responsibility in connection with the implementation of this information.

It cannot be assumed that this manual contains all measures and concepts required for specific conditions or circumstances. This document should be used for educational purposes and is not considered a legal document. Individuals who are responsible for hydraulic equipment, cross-connection control, backflow prevention or water distribution should obtain and comply with the most recent federal, state, and local regulations relevant to these sites and are urged to consult with OSHA, the EPA and other appropriate federal, state and local agencies.

Technical Learning College's Scope and Function

Welcome to the Program,

Technical Learning College (TLC) offers affordable continuing education for today's working professionals who need to maintain licenses or certifications. TLC holds several different governmental agency approvals for granting of continuing education credit.

TLC's delivery method of continuing education can include traditional types of classroom lectures and distance-based courses or independent study. TLC's distance based or independent study courses are offered in a print - based distance educational format. We will beat any other training competitor's price for the same CEU material or classroom training.

Our courses are designed to be flexible and for you to finish the material at your convenience. Students can also receive course materials through the mail. The CEU course or e-manual will contain all your lessons, activities and instruction to obtain the assignments. All of TLC's CEU courses allow students to submit assignments using e-mail or fax, or by postal mail. (See the course description for more information.)

Students have direct contact with their instructor—primarily by e-mail or telephone. TLC's CEU courses may use such technologies as the World Wide Web, e-mail, CD-ROMs, videotapes and hard copies. (See the course description.) Make sure you have access to the necessary equipment before enrolling; i.e., printer, Microsoft Word and/or Adobe Acrobat Reader. Some courses may require proctored closed-book exams, depending upon your state or employer requirements.

Flexible Learning

At TLC, there are no scheduled online sessions or passwords you need contend with, nor are you required to participate in learning teams or groups designed for the "typical" younger campus based student. You will work at your own pace, completing assignments in time frames that work best for you. TLC's method of flexible individualized instruction is designed to provide each student the guidance and support needed for successful course completion.

Course Structure

TLC's online courses combine the best of online delivery and traditional university textbooks. You can easily find the course syllabus, course content, assignments, and the post-exam (Assignment). This student-friendly course design allows you the most flexibility in choosing when and where you will study.

Classroom of One

TLC offers you the best of both worlds. You learn on your own terms, on your own time, but you are never on your own. Once enrolled, you will be assigned a personal Student Service Representative who works with you on an individualized basis throughout your program of study. Course specific faculty members (S.M.E.) are assigned at the beginning of each course providing the academic support you need to successfully complete each course. Please call or email us for assistance.

Satisfaction Guaranteed

We have many years of experience, dealing with thousands of students. We assure you, our customer satisfaction is second to none. This is one reason we have taught more than 20,000 students.

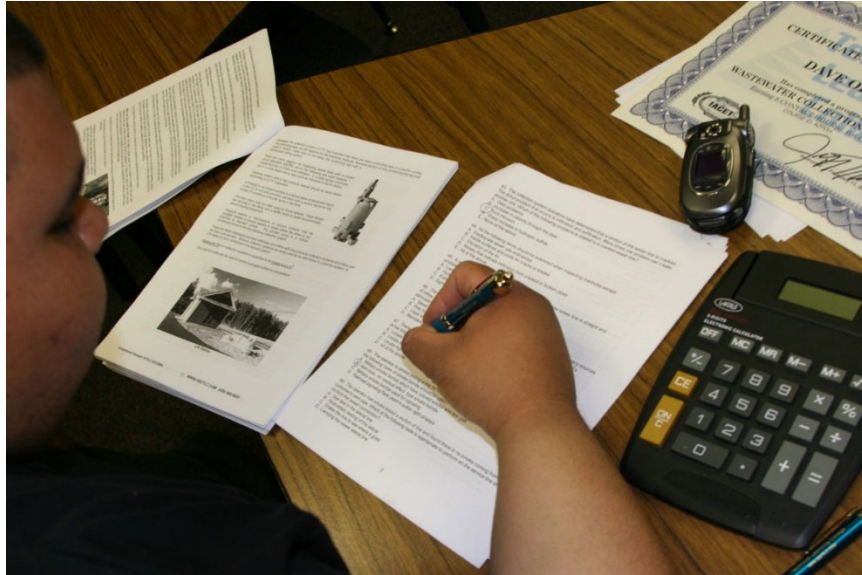

We welcome you to do the electronic version of the assignment and submit the answer key and registration to us either by fax or e-mail. If you need this assignment graded and a certificate of completion within a 48-hour turn around, prepare to pay an additional rush charge of \$50.

Contact Numbers
Fax (928) 468-0675
Email Info@tlch2o.com
Telephone (866) 557-1746

CEU Course Description

VALVE OPERATION & SYSTEM DESIGN CEU TRAINING COURSE

This short technical continuing education course will address the function, application and selection of various valves (control devices) used in every stage of the water treatment cycle from raw water intake to the treated wastewater discharge. This course will cover criteria for selecting and applying check valves, air relief, automatic valves on wells, in raw water pumping stations, in the water treatment plant, and in potable water storage and distribution systems as well as in sewage lift stations, on force mains, in wastewater treatment plants, on effluent and reuse pumping.

This course will also review hydraulic fundamentals and principles. Following this short course, the student will develop an understanding of the engineering science pertaining to liquid pressure and flow. This course will cover the basics of hydraulic fundamentals commonly related to the study of the mechanical properties of water in relationship to valves or valving. This course will also examine hydrostatics or fluid mechanics as well as the history and development of pumps, valving, hydraulics and the science of fluids. This training course will present several familiar topics in hydraulics and hydrostatics which often appear in most educational expositions of introductory science, and which are also of historical interest and can enliven a student's educational experience. ***You will not need any other materials for this course.***

Water Distribution, Well Drillers, Pump Installers, Water Treatment Operators, Wastewater Treatment Operators, Wastewater Collection Operators, Industrial Wastewater Operators and General Backflow Assembly Testers. The target audience for this course is the person interested in working in a water or wastewater treatment or distribution/collection facility and/or wishing to maintain CEUs for certification license or to learn how to do the job safely and effectively, and/or to meet education needs for promotion.

The topics which will be covered by this short CEU course include:

- Basic surge pressure wave theory.
- Linear Valves.
- Rotary Valves.
- Pressure Relief and Pressure regulating Valves.
- Check Valves.
- Surge preventing pump control valves, Surge protecting anticipator and relief valves.
- Pumping cost comparisons for pump stations.
- Pressure control, Level control and Flow control.
- Cavitation causes and solutions.
- Valve sizing considerations.
- Automatic air valves for water and sewage systems.
- Various and Interesting Hydraulic Principles.



Final Examination for Credit

Opportunity to pass the final comprehensive examination is limited to three attempts per course enrollment

Prerequisites: None

Course Procedures for Registration and Support

All of Technical Learning College's correspondence courses have complete registration and support services offered. Delivery of services will include, e-mail, web site, telephone, fax and mail support. TLC will attempt immediate and prompt service.

When a student registers for a distance or correspondence course, he/she is assigned a start date and an end date. It is the student's responsibility to note dates for assignments and keep up with the course work. If a student falls behind, he/she must contact TLC and request an end date extension in order to complete the course. It is the prerogative of TLC to decide whether to grant the request. All students will be tracked by a unique number will be assigned to the student.

Instructions for Assignment

The **Valve Operation & System Design** CEU training course uses a multiple choice type answer key. You can find a copy of the answer key in the back of this course manual in a Word format on TLC's website under the Assignment Page. You can also find complete course support under the Assignment Page.

You can write your answers in this manual or type out your own answer key. TLC would prefer that you type out and e-mail the final exam to TLC, but it is not required.

Feedback Mechanism (examination procedures)

Each student will receive a feedback form as part of their study packet. You will be able to find this form in the rear of the course or lesson.

Security and Integrity

All students are required to do their own work. All lesson sheets and final exams are not returned to the student to discourage sharing of answers. Any fraud or deceit and the student will forfeit all fees and the appropriate agency will be notified.

Grading Criteria

TLC will offer the student either pass/fail or a standard letter grading assignment. If TLC is not notified, you will only receive a pass/fail notice.

Required Texts

The **Valve Operation & System Design** CEU training course will not require any other materials. This course comes complete. No other materials are needed.

Recordkeeping and Reporting Practices

TLC will keep all student records for a minimum of seven years. It is your responsibility to give the completion certificate to the appropriate agencies.

You will have 90 days from receipt of this manual to complete in order to receive your Continuing Education Units (**CEUs**) or Professional Development Hours (**PDHs**). A score of 70% or better is necessary to pass this course. If you should need any assistance, please email all concerns and the final test to: info@tlch2o.com.

Educational Mission

The educational mission of TLC is:

To provide TLC students with comprehensive and ongoing training in the theory and skills needed for the environmental education field,

To provide TLC students opportunities to apply and understand the theory and skills needed for operator certification and environmental education,

To provide opportunities for TLC students to learn and practice environmental educational skills with members of the community for the purpose of sharing diverse perspectives and experience,

To provide a forum in which students can exchange experiences and ideas related to environmental education,

To provide a forum for the collection and dissemination of current information related to environmental education, and to maintain an environment that nurtures academic and personal growth.



Please call TLC if you need any assistance with this course or assignment.

Always check with your State agency to see if this course is accepted.

Toll Free (866) 557-1746

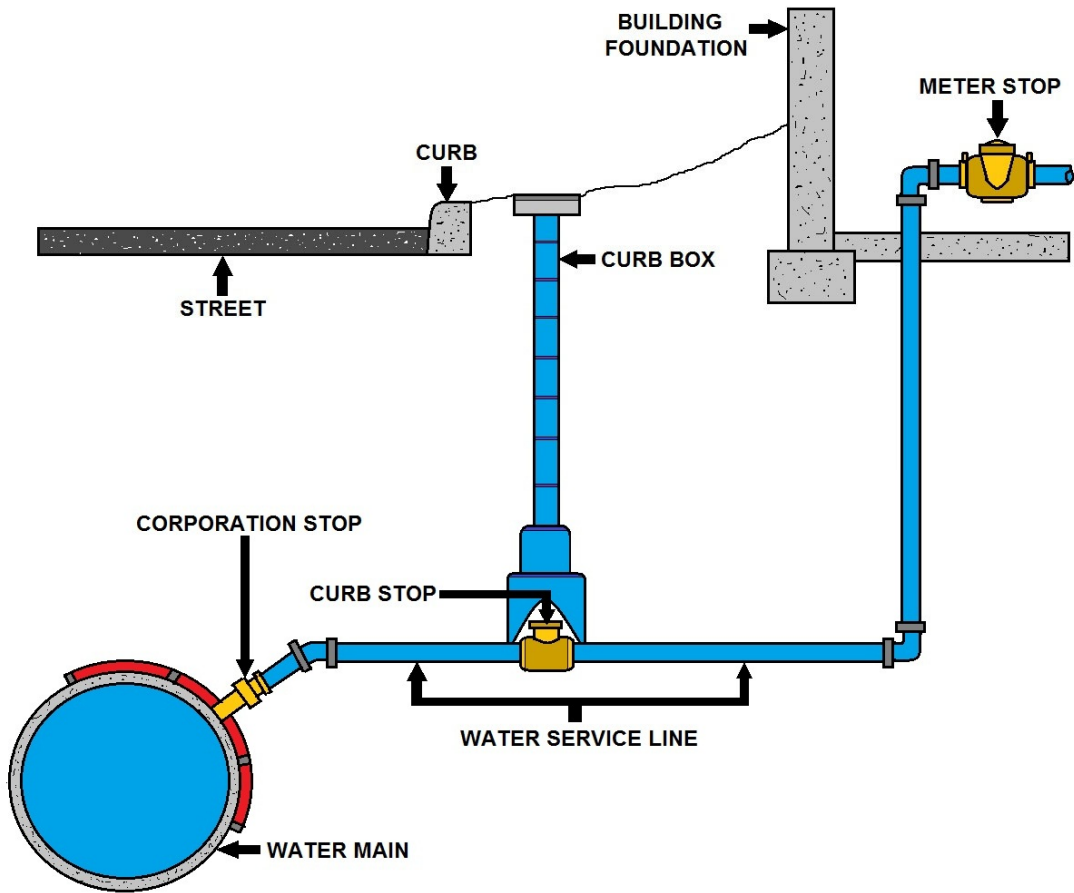

ONE VARIATION OF COMMON WATER METER INSTALLATION METHOD

TABLE OF CONTENTS

Introduction	17
System Layouts.....	19
Classifications.....	21
Valve Glossary.....	31
Rotary Valves.....	33
Bellow Seal	35
Ball Stop Valves.....	39
Butterfly.....	43
Butterfly Problems.....	45
Actuators.....	47
Air Relief Valves.....	49
Pressure Reducing.....	53
Altitude Valve.....	64
Check Valve.....	65
Valve Exercising.....	67
Water Hammer.....	69
Hydraulic Principles.....	71
Atmospheric Pressure.....	72
Barometric Loop.....	73
Geometric Arguments.....	76
Vacuum.....	77
Archimedes.....	81
Development Hydraulics.....	89
Pascal's Law.....	93
Bernoulli's Principles.....	95
Hydraulic Lever.....	97
Dudley Castle Engine.....	99
Hydrostatic Paradox.....	103
How Buoyancy Works.....	104
Hydrometer	107
Backflow Introduction.....	109
Actual Events.....	110
Cross-Connections.....	113
Pressure Vacuum Breaker.....	122
Reduced Pressure Principle Assembly.....	124
Distribution Section.....	127
New EPA Rules.....	131
Distribution Water Quality.....	139
Types of Joints.....	143
Glossary.....	151
Appendixes.....	193
Math Exercise.....	215

Common Hydraulic Terms

Head

The height of a column or body of fluid above a given point expressed in linear units. Head is often used to indicate gauge pressure. Pressure is equal to the height times the density of the liquid.

Head, Friction

The head required to overcome the friction at the interior surface of a conductor and between fluid particles in motion. It varies with flow, size, type, and conditions of conductors and fittings, and the fluid characteristics.

Head, Static

The height of a column or body of fluid above a given point.

Hydraulics

Engineering science pertaining to liquid pressure and flow.

Hydrokinetics

Engineering science pertaining to the energy of liquid flow and pressure.

Pascal's Law

A pressure applied to a confined fluid at rest is transmitted with equal intensity throughout the fluid.

Pressure

The application of continuous force by one body upon another that it is touching; compression. Force per unit area, usually expressed in pounds per square inch (Pascal or bar).

Pressure, Absolute

The pressure above zone absolute, i.e. the sum of atmospheric and gauge pressure. In vacuum related work it is usually expressed in millimeters of mercury. (mmHg).

Pressure, Atmospheric

Pressure exerted by the atmosphere at any specific location. (Sea level pressure is approximately 14.7 pounds per square inch absolute, 1 bar = 14.5 psi.)

Pressure, Gauge

Pressure differential above or below ambient atmospheric pressure.

Pressure, Static

The pressure in a fluid at rest.



A cut-away of a ball valve. The ball is made of plastic in this valve. The balls are not perfectly round but are egg shaped or elongated to make a good seal. A Ball valve has a full bore opening. A Ball Valve can be used for Chlorine only if it is a vented valve.



Introduction to Valves and Operation

System design depends on the area that you live. You may be a flatlander, like in Texas, and the services could be spread out for miles. You may live in the Rocky Mountain area and have many fluctuating elevations. Some areas may only serve residents on a part time basis and water will sit for long periods of time, while other areas may have a combination of peaks and valleys with short and long distances of service. Before you design the system you need to ask yourself some basic questions.

1. ***What is the source of water?***
2. ***What is the population?***
3. ***What kind of storage will I need for high demand and emergencies?***
4. ***How will the pressure be maintained?***

System Elements

The elements of a water distribution system include: distribution mains, arterial mains, storage reservoirs, and system accessories. These elements and accessories are described as follows:

DISTRIBUTION MAINS Distribution mains are the pipelines that make up the distribution system. Their function is to carry water from the water source or treatment works to users.

ARTERIAL MAINS Arterial mains are distribution mains of large size. They are interconnected with smaller distribution mains to form a complete gridiron system.

STORAGE RESERVOIRS Storage reservoirs are structures used to store water. They also equalize the supply or pressure in the distribution system. A common example of a storage reservoir is an aboveground water storage tank.

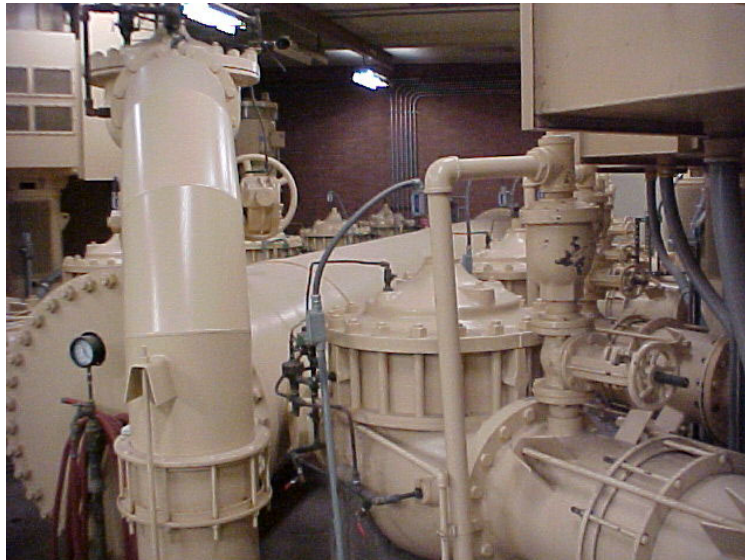

The inside of a booster pump station, notice the PRV with air relief valve.

Commonly found system accessories include the following:

Booster stations are used to increase water pressure from storage tanks for low-pressure mains.

Valves control the flow of water in the distribution system by isolating areas for repair or by regulating system flow or pressure. We will explore this component later in this course.



Two different styles of Gate Valves.

Top photograph is valve ready for a valve replacement. Bottom photograph is OS&Y commonly found on fire lines. (Outside Screw and Yoke) As the gate is lifted or opened, the stem will rise. Gate valves should be only be used in the distribution system for main line isolation.



System Layouts

There are three general ways systems are laid out to deliver water (Picture your quarter section layouts). They include:

- A. Tree systems
- B. Loop or Grid systems
- C. Dead-end systems. ***Taste and odor problems.***

Tree System

Older water systems frequently were expanded without planning and developed into a treelike system. This consists of a single main that decreases in size as it leaves the source and progresses through the area originally served. Smaller pipelines branch off the main and divide again, much like the trunk and branches of a tree.

A treelike system is not desirable because the size of the old main limits the expansion of the system needed to meet increasing demands. In addition, there are many dead ends in the system where water remains for long periods, causing undesirable tastes and odors in nearby service lines.

The most reliable means to provide water for firefighting is by designing redundancy into the system. There are several advantages gained by laying out water mains in a loop or grid, with feeder and distributor mains interconnecting at roadway intersections and other regular intervals.



Always remember to use shoring and proper safety equipment when working underground. You should also wear your hard hats as well. We are professionals and need to look like it. Bottom photograph 15 feet deep and no way out. Let's think before doing work.



Distribution Valves

The purpose of installing shutoff valves in water mains at various locations within the distribution system is to allow sections of the system to be taken out of service for repairs or maintenance, without significantly curtailing service over large areas.

Valves should be installed at intervals not greater than 5,000 feet in long supply lines, and 1,500 feet in main distribution loops or feeders. All branch mains connecting to feeder mains or feeder loops should have valves installed as close to the feeders as practical. In this way, branch mains can be taken out of service without interrupting the supply to other locations.



In the areas of greatest water demand or when the dependability of the distribution system is particularly important, valve spacing of 500 feet may be appropriate.

At intersections of distribution mains, the number of valves required is normally one less than the number of radiating mains. The valve omitted from the line is usually the one that principally supplies flow to the intersection.

Shutoff valves should be installed in standardized locations (that is, the northeast corner of intersections or a certain distance from the center line of streets), so they can be easily found in emergencies. All buried small- and medium-sized valves should be installed in valve boxes. For large shutoff valves (about 30 inches in diameter and larger), it may be necessary to surround the valve operator or entire valve within a vault or manhole to allow repair or replacement.

Classification of Valves

There are two major classifications of water valves: **Rotary and Linear**. Linear is a fancy word for up and down or blade movement.

Gate Valve Linear Valve *Our primary Linear valve*
The most common valve in the distribution system. Primarily used for main line shut downs. Should be exercised on annual basis.

Gate valves are used when a straight-line flow of fluid and minimum flow restriction are needed. Gate valves are so-named because the part that either stops or allows flow through the valve acts somewhat like a gate. The gate is usually wedge-shaped. When the valve is wide open, the gate is fully drawn up into the valve bonnet. This leaves an opening for flow through the valve the same size as the pipe in which the valve is installed.



Therefore, there is little pressure drop or flow restriction through the valve. Gate valves are not suitable for throttling purposes. The control of flow is difficult because of the valve's design, and the flow of fluid slapping against a partially open gate can cause extensive damage to the valve. Except as specifically authorized, gate valves should not be used for throttling.



Normal day, get used to working in the mud.

The Singing Key

Dr. Rusty recommends that you listen to the Valve Key when shutting down a Gate valve. You will easily hear it sing as you shut the water off or leak by. It is very easy to create a water hammer when opening or closing a Gate valve. Always take your time when operating a Gate valve or any valve. I know that most of you will not listen to me and you will end up breaking plastic water services and customer's water lines at first. Next, you'll move up to water main breaks. We like to blame the Fire Department or Street Sweepers for water hammers, and they should be blamed, but most water hammers are created by water personnel. Yes, I said it. A great example is watching a rookie shut down or open a fire hydrant. These young rookies like to turn the hydrant on or off as fast as possible, like the Firemen do. Pretty soon, the hydrant starts chattering and pumping. The ground feels like an earthquake and the rookie pretends that nothing is happening. We've all done this and if you haven't, you've probably never worked in the field.

Problems

Valve Jammed Open

Dr. Rusty recommends that opened valves should not be jammed-tight on the backseat.

Always back the valve-off a quarter turn from the fully opened position.

Note that motor operated valves coast inevitably to the backseat by tripping on a limit switch. Valves should not be back seated on torque.

Valve Jammed Closed

Variations in the temperature and/or pressure of the working fluid are often the cause of a valve failing to open.

Thermal binding can occur in high temperature situations depending on the seat and wedge material, length of exposure and closing torque applied. Thermal binding can cause galling on the valve sealing surfaces as well as on the guides.

A valve can lock in the closed position when high pressure enters the cavity and has no way to escape. This is known as over-pressurization.

If Excessive Torque is Needed to Work the Valve

Variations in the temperature and/or pressure of the working fluid are often the cause of a valve failing to open.

Thermal binding can occur in high temperature situations depending on the seat and wedge material, length of exposure and closing torque applied. Thermal binding can cause galling on the valve sealing surfaces as well as on the guides. A valve can lock in the closed position when high pressure enters the cavity and has no way to escape. This is known as over-pressurization. We will cover this in a later section.

Single direction sealing gate valves have a nameplate on the side of the valve that has a relief hole or pressure equalizer. This should be the high pressure side when the valve is closed.



Here is a 4 inch broken gate valve with serious Tuberculation. The valve is broken closed. The rust particles are sharp and can easily cut the water service worker. The flange bolts or Tee bolts were cut off to replace this valve. The rubber gasket will leave a black ink like stain on your clothes and in the water line as well.



Notice the corrosion inside this cast iron main.

This corrosion is caused by chemical changes produced by electricity or electrolysis. We call this type of corrosion tuberculation. It is a protective crust of corrosion products that have built up over a pit caused by the loss of metal, due to corrosion or electrolysis. This type of corrosion will decrease the C-Factor and the carrying capacity in a pipe. Crenothrix bacteria or Red-Iron bacteria will live in the bioslime in this type of tuberculation.

For dealing with this bacteria—there are two methods: the fast method, super chlorinate and flush forever. Or, replace the line with a nice plastic water main. It is up to your supervisor, but remember the nasty bacteria in the water. No one that knows about this problem will ever drink water from the house service. We need to do a better job.



Gate valve storage procedures. Always store a gate valve with the gate up or opened. Not like this photograph. Sunlight will destroy the rubbers with ultraviolet radiation. Dr. Rusty recommends that you keep the valves covered and clean and I want you to do the same. We are professionals and must remember the final outcome. We provide drinking water to the public. Notice the two different styles of flange fittings.

Knife Gate Valve

Always follow standard safety procedures when working on a valve. Install the valve so that the arrows on both sides of the body are in the direction of positive pressure differential.

The preferred orientation is with the stem vertical and the handwheel pointing up. The opposite orientation is not recommended, because fiber and dirt can build-up in the bonnet.

Service connections are used to connect individual buildings or other plumbing systems to the distribution system mains. See the Angle stop.

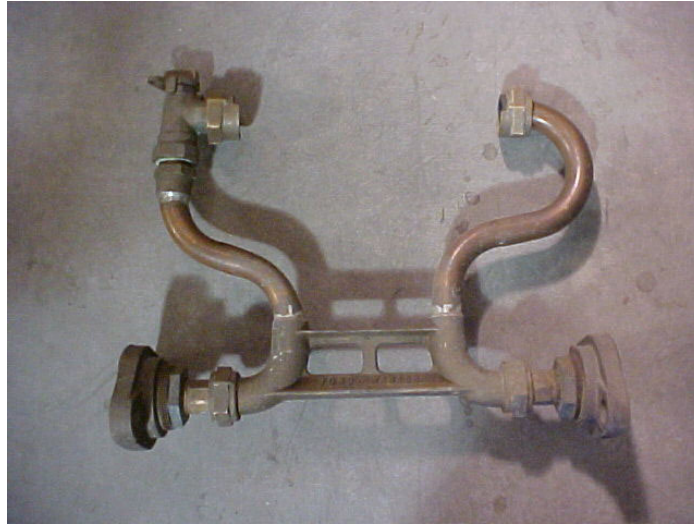

Water Meter Re-setter, Riser or sometimes referred to as a copper yoke. There is also a cast iron version which is best broken off with two sledge or cocking hammers when it's time to replace or retrofit the service. You almost always replace a yoke stop hot. A Yoke stop is an Angle Stop most of the time but I've seen a nasty galvanized valve that is also used in this situation.



Common distribution fittings: Single check, Poly Pig, 1 inch repair clamp, 4 inch full circle clamp, T- Bolt and a corp. and saddle. Note from Dr. Rusty, Single checks are not a backflow assembly and will probably stick open over time. I know that most systems will pay for these but unless you replace or test these checks, they will not hold up. Most fitting salesmen will not tell you this little tidbit. Notice the Corp, it is a ball type valve.



Ductile pipe cement-lined iron pipe. I've seen thousands of dollars of pipe that is dropped or moved with the front bucket of a backhoe and destroyed. This destroys the interior protection of the pipe, causing leaks which will start in a few years. I know that some of you welcome this as job security. These nitwits need job security, but water professionals do not need crappy work to keep them employed. Always protect and store all types of pipe covered and in a pipe rack. This goes for the proper storage of rubbers as well.



Flex Coupling--sometimes referred to as a Dayton; used to join pipes or to "cut-in a valve." You will learn that you can use different sizes to join pipe or even file out the inside diameter to adjust to larger pipes like ACP. This flex coupling only has three bolts. I like four or more for work with larger pipe work. Dr. Rusty's trick, when working on a water line, I like to turn the valves on slowly to fill the water main as the flex couplings are being tightened. This allows the air to escape and for you to find leaks. It also allows debris in the main to flush out.



Here is a four-way pipe cutting tool used for iron pipe. Be careful not to break the wheels by over-tightening. I personally like 4-Ways because of the nice cut. You will learn to recognize the distinct snap of cut pipe. The only drawback to these cutters is cutting a small section out of the main. You may need to make two or three more cuts and break the section out with a cocking hammer. It will easily cut ductile, galvanized, and even plastic. Plastic pipe cutters utilize sharper cutting wheels. Rookies like to thread the pipe rather than cut the pipe. It is fun to watch and good to tease these rookies about it. Especially if they have just finished jumping a stop with the valve closed or no ball. Good times for sure in the crazy Distribution field.

Photograph on right, difficult to see, these are pipe crimpers. These will easily and effectively stop flow in copper or plastic pipe in tubing less than 2 inches. The only problem is dealing with the crimp when you are finished. I suggest placing a flex coupling over the crimp in plastic and completely cutting the crimped area out when done in copper pipe.





Top photograph, two gate valves blew out, you can see the kickers or thrust blocks remaining in the back ground. Bottom photograph, a tapping machine and a new gate valve. These tapping machines are very, very expensive.



Valve Glossary

Here are some of the common valves and related information.

Air and Vacuum relief valve: Both of these functions are in one valve. These valves can combine three functions; they can allow large amounts of air to escape during the filling of a pipeline, permits air to enter a pipeline that is being drained and allow entrained air to escape while a line is operating under pressure. Distribution system water quality can be adversely affected by improperly constructed or poorly located blowoffs of vacuum/air relief valves. Air relief valves in the distribution system lines must be placed in locations that cannot be flooded. This is to prevent water contamination. The common customer complaint of Milky Water is sometimes solved by the installation of these air relief valves.

Altitude valve: Are often used on supply lines to elevated tanks or standpipes. These close automatically when the tank is full and open when the pressure on the inlet side is less than that on the tank side of the valve. These valves control the high water level and prevent overflow. Altitude-Control Valve is designed to, 1. Prevent overflows from the storage tank or reservoir, or 2. Maintain a constant water level as long as water pressure in the distribution system is adequate.

Butterfly valve: Has a movable disc as large as the full bore opening of the valve.

Check valve: Are often used on the discharge side of pumps to prevent backflow.

Gate valve: Is a linear valve used to isolate sections of the water main, to permit emergency repairs without interruption of water service to customers.

Pressure sustaining valve: Maintains constant downstream pressure regardless of fluctuating demand. The valve is usually a globe design controlled by a diaphragm with the diaphragm assembly being the only moving part in the valve. Can also be used as an automatic flow-control valve.

Pressure regulating valve: A valve that controls water pressure by restricting flows. The pressure downstream of the valve regulates the amount of flow. Usually these valves are of the globe valve design. **Pressure Regulation Valves** control water pressure and operate by restricting flows. They are used to deliver water from a high pressure to a low-pressure system. The pressure downstream from the valve regulates the amount of flow. Usually, these valves are of the globe design and have a spring-loaded diaphragm that sets the size of the opening.

Pressure relief: The simplest type of surge pressure relief is a pressure relief valve. These valves respond to pressure variations at their inlets.

What screen size and protection should air vacuum release valves have above and below ground?

Vents should be screened to keep out birds and animals that may contaminate the water. A screen with 1/4 mesh openings is required. Some vents have flap valves that will operate to relieve excess pressure or vacuum if the screen becomes blocked.

What types of water contamination problems could result from improper installation of air vacuum and relief valves?

All overflow, blow off, or cleanout pipes should be turned downward to prevent entrance of rain and should have removable #24-mesh screens to prevent the entrance of birds, insects, rodents, and contaminating materials.

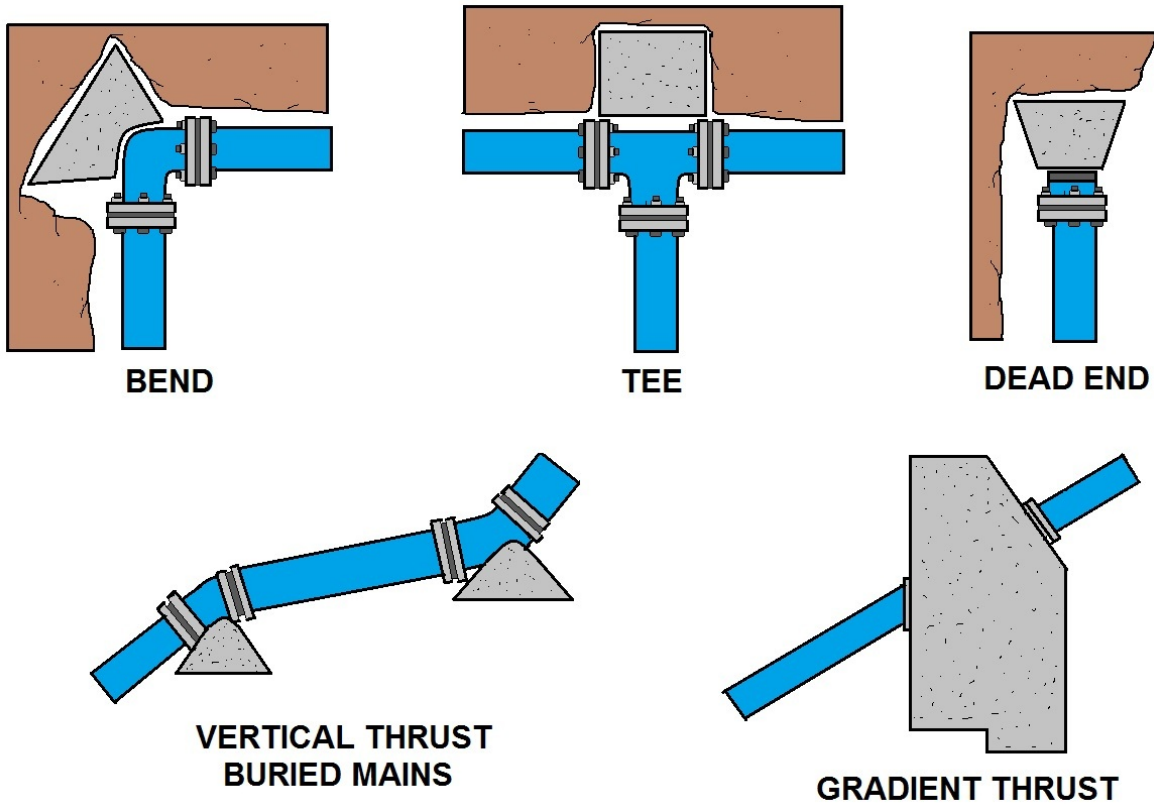

PROPER THRUST BLOCKING PROCEDURES

Common Rotary Valves

Globe Valve *Rotary Valve*

Primarily used for flow regulation, and works similar to a faucet. They are rare to find in most distribution systems, but can be found at treatment plants. Always follow standard safety procedures when working on a valve.

Most Globes have compact **OS & Y** type, bolted bonnet, rising stems with renewable seat rings. The disc results with most advanced design features provide the ultimate in dependable, economical flow control.

Globe valves should usually be installed with the inlet below the valve seat. For severe throttling service, the valve may be installed so that the flow enters over the top of the seat and goes down through it. Note that in this arrangement, the packings will be constantly pressurized. If the valve is to be installed near throttling service, verify with an outside contractor or a skilled valve technician. Globe valves, per se, are not suitable for throttling service.

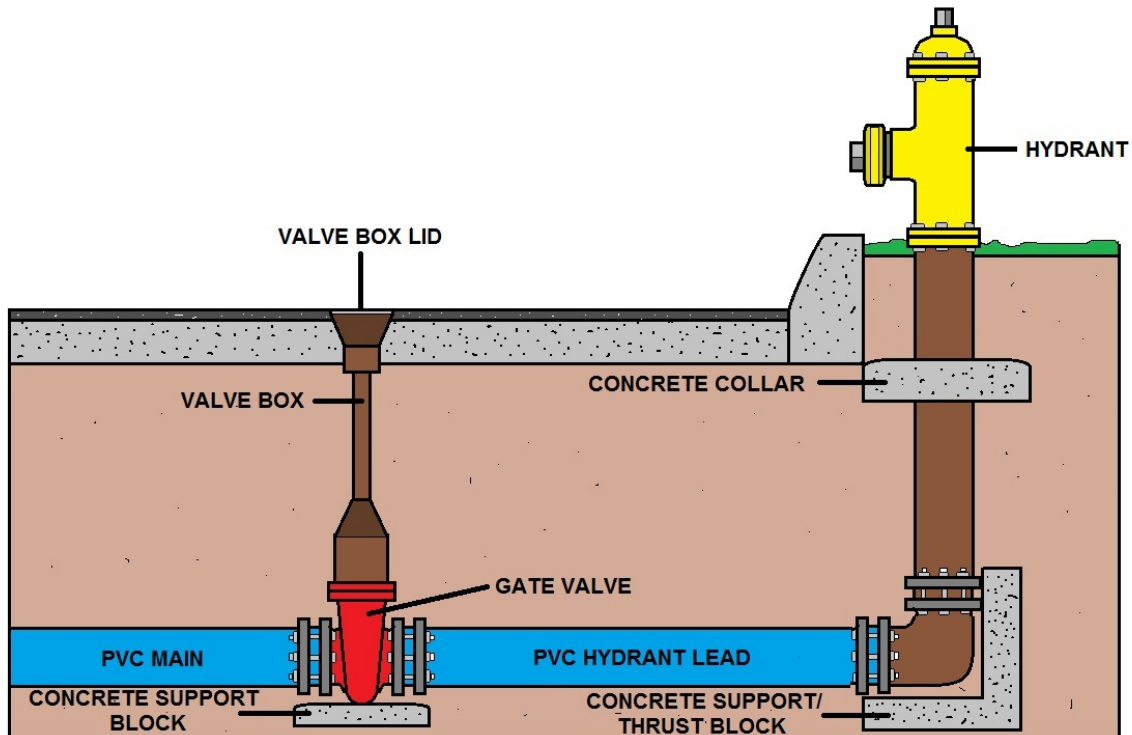

PROPER FIRE HYDRANT AND ISOLATING GATE VALVE INSTALLATION

The valve should be welded onto the line with the disc in the fully closed position. Leaving it even partially open can cause distortion and leaking. Allow time for the weld to cool before operating the valve the first time in the pipeline.

The preferred orientation of a globe valve is upright. The valve may be installed in other orientations, but any deviation from vertical is a compromise. Installation upside down is not recommended because it can cause dirt to accumulate in the bonnet.

Globe Valve Problems and Solutions

If the valve stem is improperly lubricated or damaged--Disassemble the valve and inspect the stem. Acceptable deviation from theoretical centerline created by joining center points of the ends of the stem is 0.005"/ft of stem. Inspect the threads for any visible signs of damage.

Small grooves less than 0.005" can be polished with an Emory cloth. Contact specialized services or an outside contractor if run-out is unacceptable or large grooves are discovered on the surface of the stem.

If the valve packing compression is too tight--Verify the packing bolt torque and adjust if necessary.

Foreign debris is trapped on threads and/or in the packing area.--This is a common problem when valves are installed outdoors in sandy areas and the areas not cleaned before operating.

Always inspect threads and packing area for particle obstructions; even seemingly small amounts of sand trapped on the drive can completely stop large valves from cycling.

The valve may stop abruptly when a cycle is attempted. With the line pressure removed from the valve, disconnect the actuator, gear operator or handwheel and inspect the drive nut, stem, bearings and yoke bushing.

Contaminated parts should be cleaned with a lint-free cloth using alcohol, varsol or equivalent. All parts should be re-lubricated before re-assembled. If the valves are installed outdoors in a sandy area, it may be desirable to cover the valves with jackets.

If the valve components are faulty or damaged--contact specialized services or an outside contractor.

If the valve's handwheel is too small--Increasing the size of the handwheel will reduce the amount of torque required to operate the valve. If a larger handwheel is installed, the person operating the valve must be careful not to over-torque the valve when closing it.

Bellow Seal Valve

Always follow standard safety procedures when working on a valve.

Bellows seal valves provide a complete hermetic seal of the working fluid. They are used in applications where zero leakage of the working fluid into the environment is permitted.

Bellows seal valves are specially modified versions of the standard valves. The installation information that applies to gate and globe valves will apply to bellows seal valves.

A packing leak signifies that the bellows has ruptured or the bellows-assembly weld has a crack. Dr. Rusty does not recommend repairing or reusing a damaged bellows. Instead, Dr. Rusty suggests replacing the entire bonnet assembly including bellows and stem.

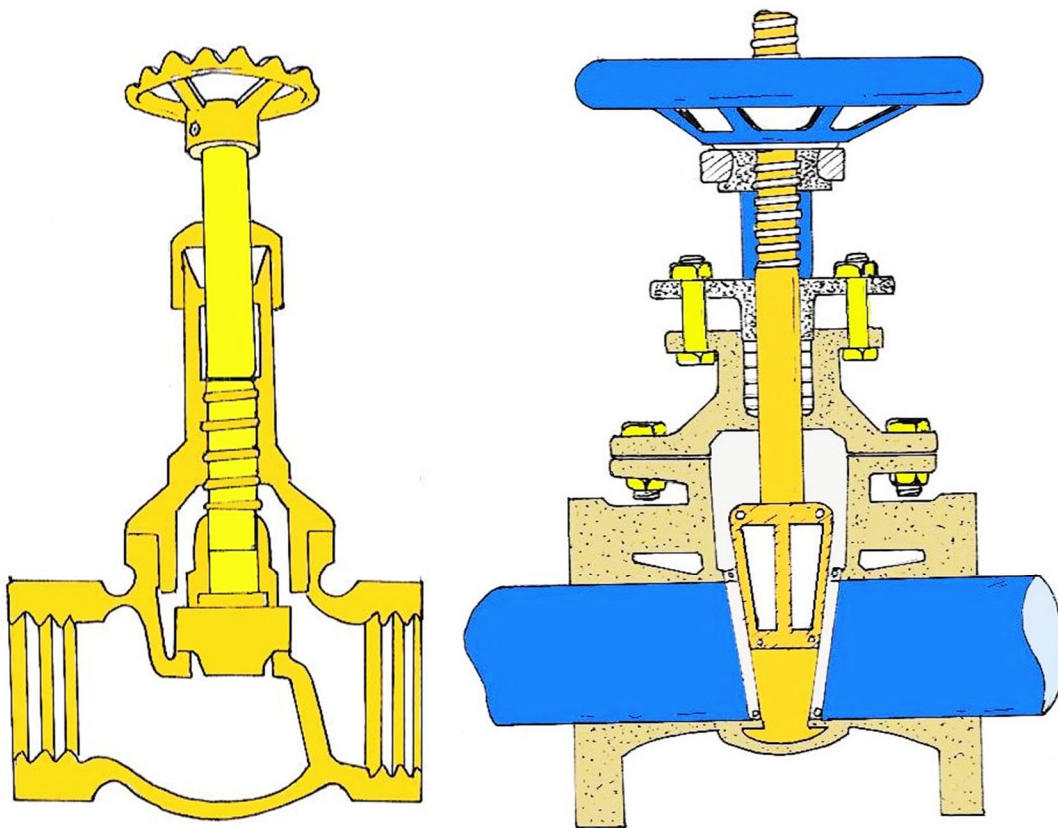

GLOBE VALVE VS RISING STEM GATE VALVE

Bellow's style Globe valve on left, Gate valve on right.

Pressure Sustaining Valve

Pressure sustaining valves are used to sustain the system pressure to a predetermined maximum level. The applications balance the pressure distribution throughout the whole system by maintaining the minimum pressure for high altitude users. Pressure sustaining valves are also used to prevent discharging of the pipe system when any user starts to operate. More in a few more pages.

Pressure Reducing Valve

Pressure reducing valves maintain a predetermined outlet pressure which remains steady and unaffected by either changing of inlet pressure and/or various demands. Pressure Reducing Valves are self-contained control valves which do not require external power. More in a few more pages.

Insertion Valves Rotary Valve

You know sometimes you can obtain a shut down and you have two choices. Do it hot or cut in an insertion or inserting valve. An Insertion valve is normally a Gate Valve that is made to be installed on a hot water main. A few years ago, this was a serious feat. First, you had to pour ten yards of mud or cement and come back and cut the valve in. No longer. The Insertion valve machine and tap works like a tapping sleeve. The only difference is that the tap points up and not to the side. I recommend that any major system budget money to purchase this equipment. It will pay for itself on the first job. Otherwise, contract the work out. You can see in the photograph a manually operated tapping machine. I prefer the electric. Note: see the sweet shoring shield set-up. It is rare to see a nice shoring job.



Hydro-Stop valve insertion machine

Needle Valves *Rotary Valve*

A needle valve, as shown on the right, is used to make relatively fine adjustments in the amount of fluid flow. The distinguishing characteristic of a needle valve is the long, tapered, needle-like point on the end of the valve stem. This "needle" acts as a disk. The longer part of the needle is smaller than the orifice in the valve seat and passes through the orifice before the needle seats. This arrangement permits a very gradual increase or decrease in the size of the opening. Needle valves are often used as component parts of other, more complicated valves. For example, they are used in some types of reducing valves.

Plug Valves *Rotary Valve*

Plug valves are extremely versatile valves that are found widely in low-pressure sanitary and industrial applications, especially petroleum pipelines, chemical processing and related fields, and power plants. They are high capacity valves that can be used for directional flow control, even in moderate vacuum systems. They can safely and efficiently handle gas and liquid fuel, and extreme temperature flow, such as boiler feed water, condensate, and similar elements. They can also be used to regulate the flow of liquids containing suspended solids (slurries).

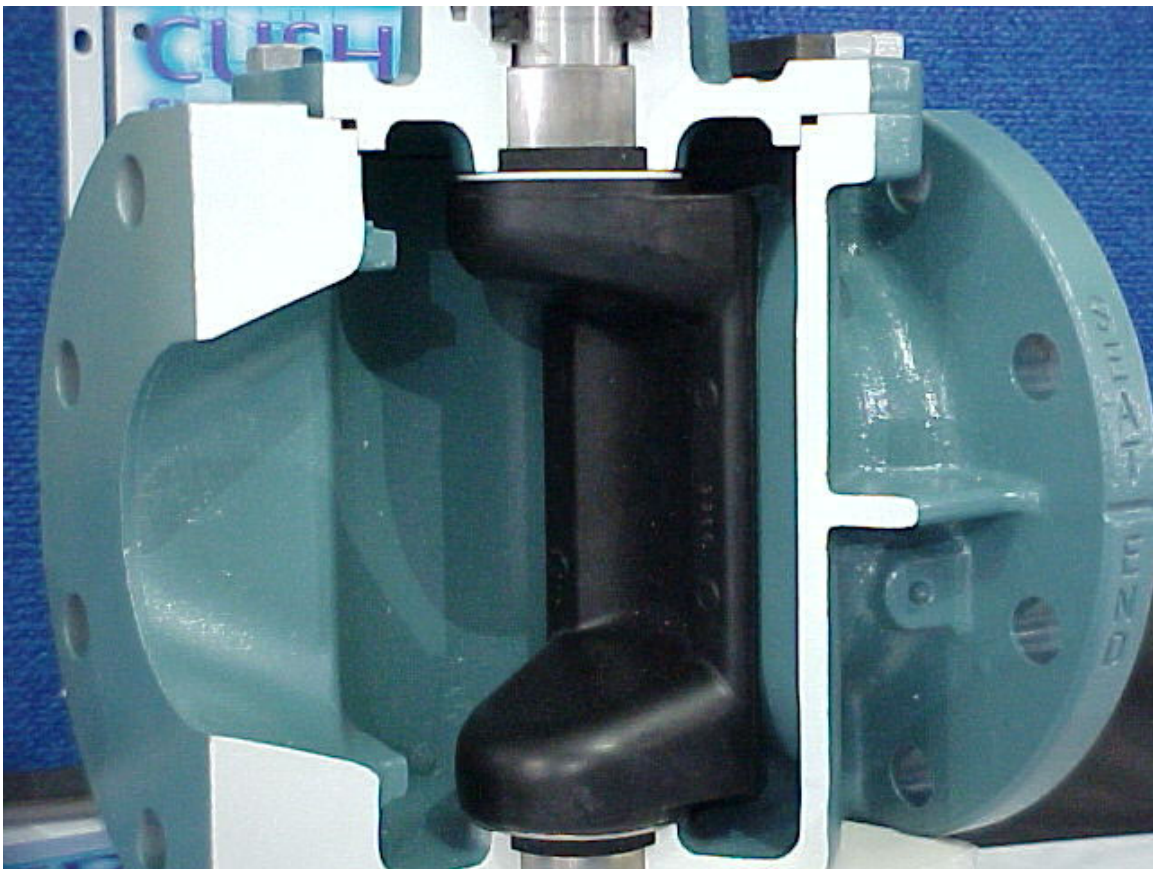

Cut-away of a Plug Valve.

Angle Stops Rotary Valve

When working in tight areas, you sometimes need a tight fitting valve. This is an excellent place for an Angle Stop or Angle valve. If you ever have to jump an Angle valve on hot, first dismantle the bottom compression fitting and the rubber and slide it on the water line. Sometimes the bottom compression fitting will have a set-screw and some operators like to tighten it to the pipe or service before jumping the stop. Either way, it will work. Always have a helper if jumping any service larger than 1 inch.



Get in there and jump that corp! It is best to use a broomstick and stab the corp if possible. Another good trick to get a 5 foot section of plastic 2 inch pipe and cover the corp. This will also pump the hole dry as you turn off the corp or the main line. It is called the “old vacuum trick”.

Ball or Corporation Stop *Rotary Valve* *Small Valves 2 inches and smaller*

Most commonly found on customer or water meters. All small backflow assemblies will have two Ball valves. It is the valve that is either fully on or fully off; and the one that you use to test the abilities of a water service rookie. The best trick is to remove the ball from the Ball valve and have a rookie *Jump a Stop*. The Corp is usually found at the water main on a saddle. Some people say that the purpose of the Corp is to regulate the service. I don't like that explanation. No one likes to dig up the street to regulate the service and Ball valves are only to be used fully on or fully off.



Most ball valves are the quick-acting type. They require only a 90-degree turn to either completely open or close the valve. However, many are operated by planetary gears. This type of gearing allows the use of a relatively small handwheel and operating force to operate a fairly large valve. Always follow standard safety procedures when working on a valve.

The gearing does, however, increase the operating time for the valve. Some ball valves also contain a swing check located within the ball to give the valve a check valve feature. The brass ball valve is often used for house appliance and industry appliance; the size range is 1/4"-4".

Brass or zinc is common for body, brass or iron for stem, brass or iron for ball, aluminum, stainless steel, or iron for handle including a Teflon seal in the ball housing.

Flush the pipeline before installing the valve. Debris allowed to remain in the pipeline (such as weld spatters, welding rods, bricks, tools, etc.) can damage the valve.

After installation, cycle the valve a minimum of three times and re-torque bolts as required. Ensure that the valve is in the open position and the inside of the body bore of the valve body/body end is coated with a suitable spatter guard.





Bird's eye view of the coveted stainless steel ball.



Removing the ball is very difficult. I think they use a robot to tighten the rear nut to keep you from removing it. I recommend that you always use pipe dope or Teflon tape when installing a Stop. I know a lot of you think that brass or bronze will make up the slack, but pipe dope, or Teflon dope or tape makes a nicer job and makes for an easier removal.

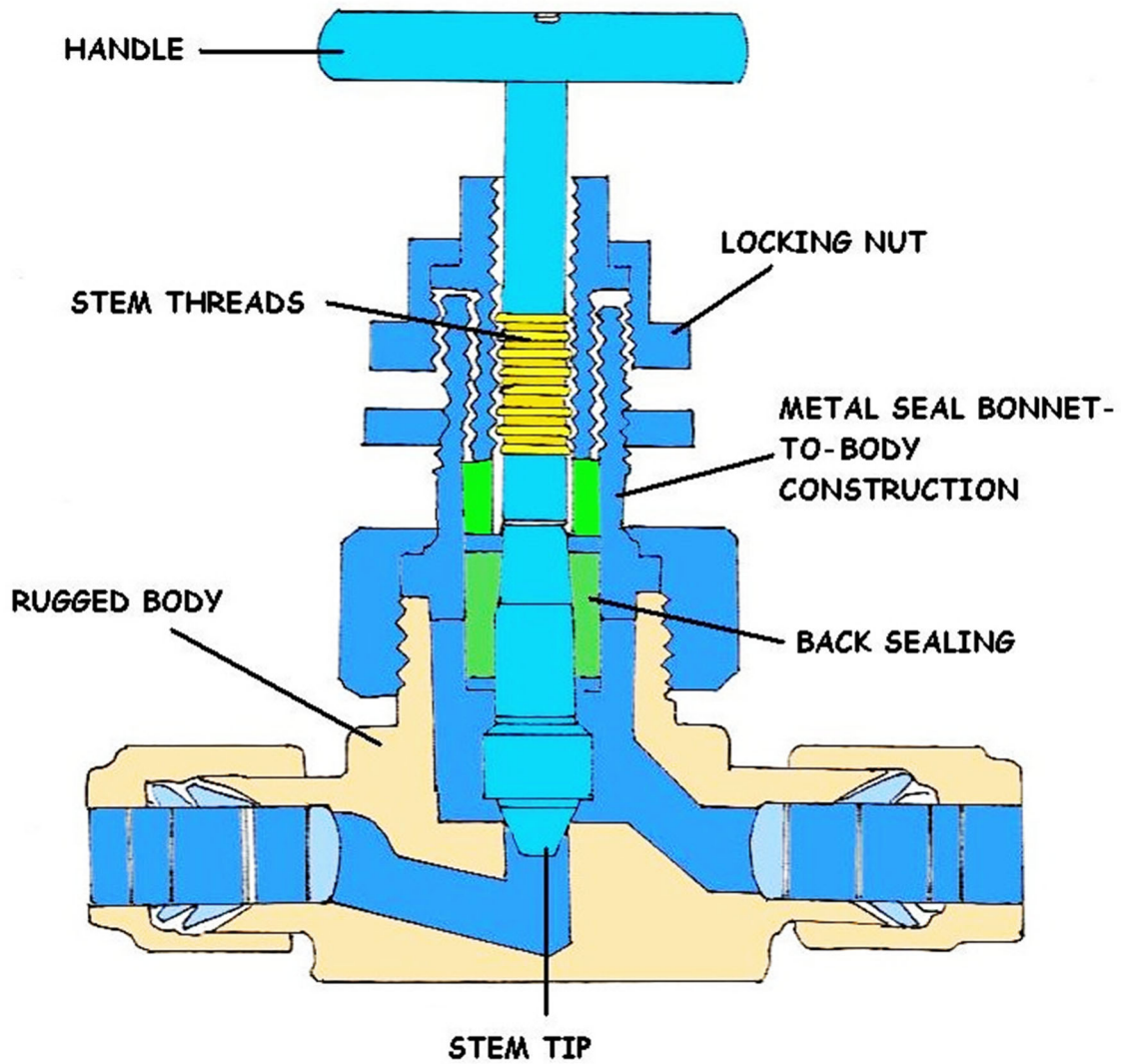

NEEDLE VALVE DIAGRAM

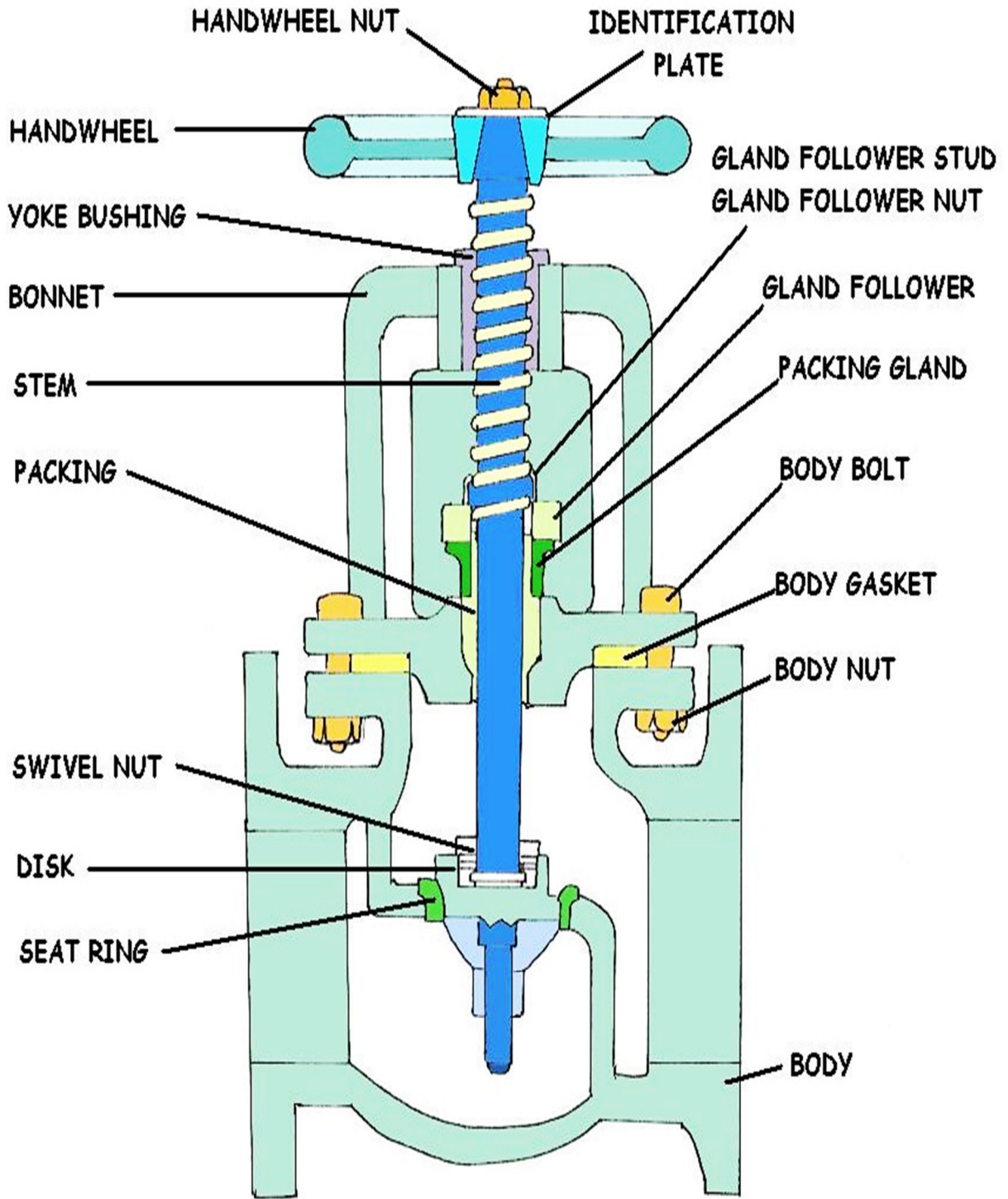

EXPANDED GLOBE VALVE DIAGRAM

Butterfly Valve Rotary Valve

Usually a huge water valve found in both treatment plants and throughout the distribution system. If the valve is not broken, it is relatively easy to operate. It is usually accompanied with a Gate valve used as a by-pass to prevent water hammer. When I was a Valve man, it seemed that every Bypass valve was broken closed when near a Butterfly valve.

These are rotary type of valves usually found on large transmission lines. They may also have an additional valve beside it known as a "**bypass valve**" to prevent a water hammer.

Some of these valves can require 300-600 turns to open or close. Most Valvemmen (or the politically correct term "Valve Operators") will use a machine to open or close a Butterfly Valve. The machine will count the turns required to open or close the valve.

Butterfly valves should be installed with the valve shaft horizontal or inclined from vertical. Always follow standard safety procedures when working on a valve.

The valve should be mounted in the preferred direction, with the "HP" marking. Thermal insulation of the valve body is recommended for operating temperatures above 392°F (200°C). The valve should be installed in the closed position to ensure that the laminated seal in the disc is not damaged during installation.

If the pipe is lined, make sure that the valve disc does not contact the pipe lining during the opening stroke. Contact with lining can damage the valve disc.

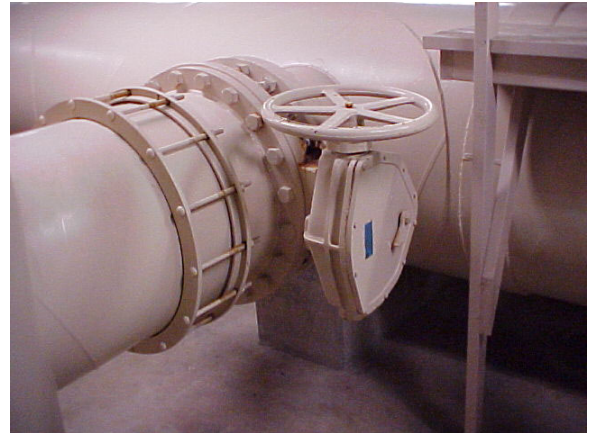

54 inch Butterfly valve on a huge transmission line. Nice job but no shoring, no ladder or valve blocking.



FEATURES & ADVANTAGES

AWWA C504, CLASS 150B, BUTTERFLY VALVES

BODY

Heavy duty cast iron furnished standard, with ductile iron available as an extra cost option. Flanged Valves are bored and drilled per ANSI B16.1, Class 125. Mechanical Joint Valves are machined per ANSI/AWWA C111A2.1.1. Wafer Valves are machined to fit between ANSI B16.1, Class 125 flanges.

SHAFT

Corrosion resistant stainless steel per ASTM A276 Type 304 furnished standard or type 316 furnished as an extra cost option. One piece design on valves sizes 3" to 8" and two piece design 10" and up. Shafts are sized to meet AWWA C504 for Class 150B Butterfly Valves.

BEARINGS

(Upper and Lower)
Fiberglass reinforced nylon bearings are low friction, self-lubricating and provide exceptionally long life.

DISC

Corrosion resistant ASTM A276, Type 316 stainless steel sizes 3", 4" and 6". High strength ASTM-A536, 65-45-12 ductile iron with a 316 stainless steel edge per AWWA C504 and fusion bond epoxy coating on sizes 8" and up. Streamlined lens-shaped disc provides minimum headloss. Discs are attached to shafts with 316 stainless steel tapered dowel pins.

SHAFT SEALS

(Upper and Lower)
Buna-N (Nitrile) Chevron V backing is self adjusting and provides exceptionally long life.

RESILIENT BODY SEAT

Standard Material is Buna-N (Nitrile) Rubber, permanently bonded to the iron body and tested per AWWA Standard C504.

SELF CENTERING

DISC-NO ADJUSTMENT NECESSARY

Flats milled into the vulcanized rubber body seat mate with machined flats on the disc to provide positive centering of the disc in the body. Accurate centering of the disc in the body assures maximum seat life.

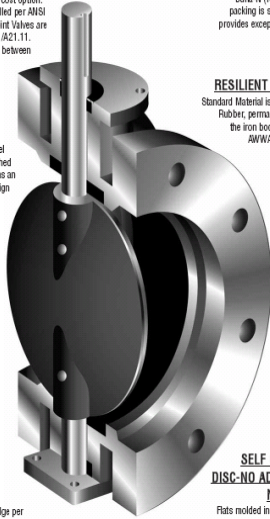

Bulletin BF150-2

AWWA STANDARD C-504 BUTTERFLY VALVES

FLANGED
WITH WORM GEAR
ACTUATOR & HANDWHEEL

WAFER
WITH 10 POSITION LEVER

M.J.
WITH TRAVELING NUT
ACTUATOR & 2" SQ. NUT

GA Industries Inc.

GA Industries Inc.

 MANUFACTURERS OF GOLDEN ANGELO PRODUCTS

ACTUATION METHODS

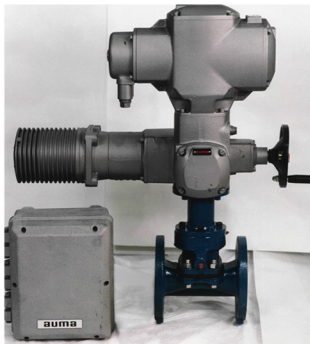

- Standard Handwheel
- Chainwheel Operated
- Square Nut
- Pneumatic
- Electric

Butterfly Valve Problems

A butterfly valve may have jerky operation for the following reasons:

If the packing is too tight--Loosen the packing torque until it is only hand tight. Tighten to the required level and then cycle the valve. Re-tighten, if required. CAUTION: Always follow safety instructions when operating on valve.

If the shaft seals are dirty or worn out--Clean or replace components, as per assembly-disassembly procedure. CAUTION: Always follow safety instructions when operating on a valve.

If the shaft is bent or warped--The shaft must be replaced. Remove valve from service and contact an outside contractor or your expert fix-it person.

If the valve has a pneumatic actuator, the air supply may be inadequate--Increase the air supply pressure to standard operating level. Any combination of the following may prevent the valve shaft from rotating:

If the actuator is not working--Replace or repair the actuator as required. Please contact specialized services or an outside contractor for assistance.

If the valve is packed with debris--Cycle the valve and then flush to remove debris. A full cleaning may be required if flushing the valve does not improve valve shaft rotation. Flush or clean valve to remove the debris.



A broken 54 inch Butterfly and a worker inside the water main preparing the interior surface. Notice, this is a Permit Required Confined Space. Hot work permit is also required. Side note, there is a plastic version of the 54 and 60 inch Butterfly valve.



Here at a water treatment plant, we can see both valve actuators control devices and Butterfly valves as well. Bottom photograph is a cut-away of an actuator and mechanism.

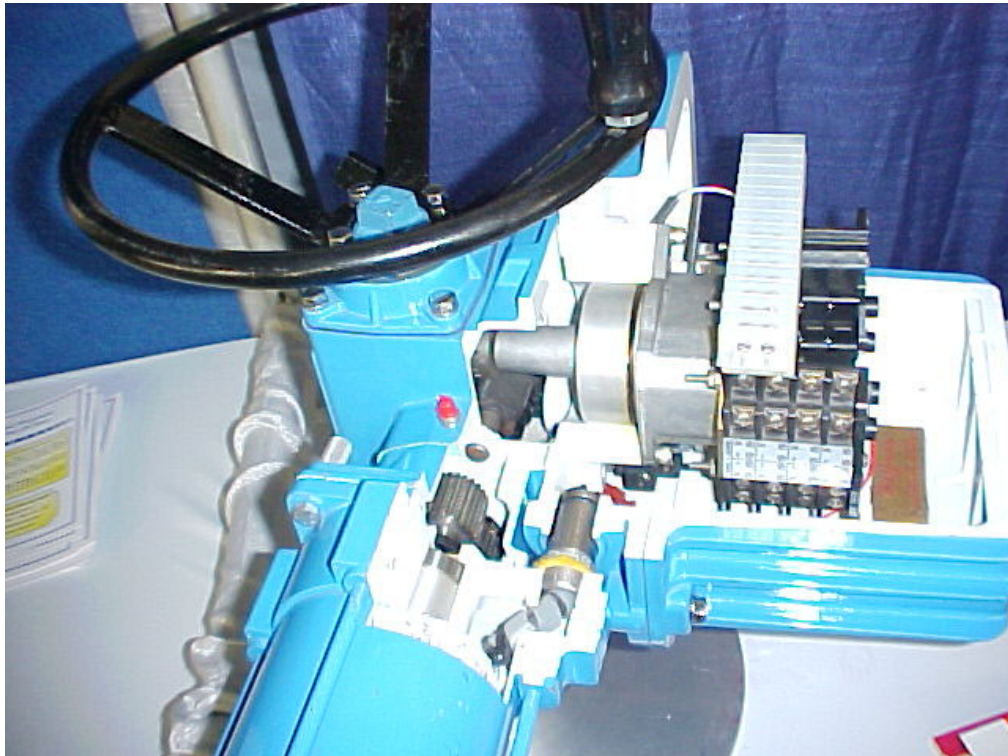

Actuators and Control Devices

Directional control valves route the fluid to the desired actuator. They usually consist of a spool inside a cast iron or steel housing. The spool slides to different positions in the housing, and intersecting grooves and channels route the fluid based on the spool's position.

The spool has a central (neutral) position maintained with springs; in this position the supply fluid is blocked, or returned to tank. Sliding the spool to one side routes the hydraulic fluid to an actuator and provides a return path from the actuator to the tank. When the spool is moved to the opposite direction the supply and return paths are switched. When the spool is allowed to return to the neutral (center) position the actuator fluid paths are blocked, locking it in position.

Directional control valves are usually designed to be stackable, with one valve for each hydraulic cylinder, and one fluid input supplying all the valves in the stack.

Tolerances are very tight in order to handle the high pressure and avoid leaking, spools typically have a clearance with the housing of less than a thousandth of an inch. The valve block will be mounted to the machine's frame with a three point pattern to avoid distorting the valve block and jamming the valve's sensitive components.

The spool position may be actuated by mechanical levers, hydraulic pilot pressure, or solenoids which push the spool left or right. A seal allows part of the spool to protrude outside the housing, where it is accessible to the actuator.

The main valve block is usually a stack of off the shelf directional control valves chosen by flow capacity and performance. Some valves are designed to be proportional (flow rate proportional to valve position), while others may be simply on-off. The control valve is one of the most expensive and sensitive parts of a hydraulic circuit.

Pressure reducing valves reduce the supply pressure as needed for various circuits. Pressure relief valves are used in several places in hydraulic machinery: on the return circuit to maintain a small amount of pressure for brakes, pilot lines, etc.; on hydraulic cylinders, to prevent overloading and hydraulic line/seal rupture; on the hydraulic reservoir, to maintain a small positive pressure which excludes moisture and contamination.

Sequence valves control the sequence of hydraulic circuits; to insure that one hydraulic cylinder is fully extended before another starts its stroke, for example. Shuttle valves provide a logical function.

Check valves are one way valves, allowing an accumulator to charge and maintain its pressure after the machine is turned off, for example.

Pilot controlled Check valves are one way valves that can be opened (for both directions) by a foreign pressure signal. For instance, if the load should not be held by the check valve anymore. Often the foreign pressure comes from the other pipe that is connected to the motor or cylinder.

Counterbalance valves. A counterbalance valve is, in fact, a special type of pilot controlled check valve. Whereas the check valve is open or closed, the counterbalance valve acts a bit like a pilot controlled flow control.

Cartridge valves are in fact the inner part of a check valve; they are off the shelf components with a standardized envelope, making them easy to populate a proprietary valve block. They are available in many configurations: on/off, proportional, pressure relief, etc. They generally screw into a valve block and are electrically controlled to provide logic and automated functions.

Hydraulic fuses are in-line safety devices designed to automatically seal off a hydraulic line if pressure becomes too low, or safely vent fluid if pressure becomes too high.

Auxiliary valves. Complex hydraulic systems will usually have auxiliary valve blocks to handle various duties unseen to the operator, such as accumulator charging, cooling fan operation, air conditioning power, etc... They are usually custom valves designed for a particular machine, and may consist of a metal block drilled with ports and channels. Cartridge valves are threaded into the ports and may be electrically controlled by switches or a microprocessor to route fluid power as needed.



Here is an Operator who is very fortunate to be able to utilize electronic or SCADA control of the valves at a modern treatment facility.

Why use automatic air valves?

- Increase flow capacity
- Reduce pumping costs (less electricity)
- Lessen the effect of water hammer.
- Prevent vacuum damage, such as pipeline collapse, seal failure, contamination and cross connection.
- Keep the lines full to reduce corrosion of the pipe.



Air pockets reduce the cross sectional area of the pipe available to transmit the fluid, similar to partially closed valves. The velocity will increase at all air pockets and therefore the system head loss also increases.

The flow in the pipeline will push the air pocket down the pipe. The location of air valves should be at the point of the anticipated air pocket during flowing conditions.

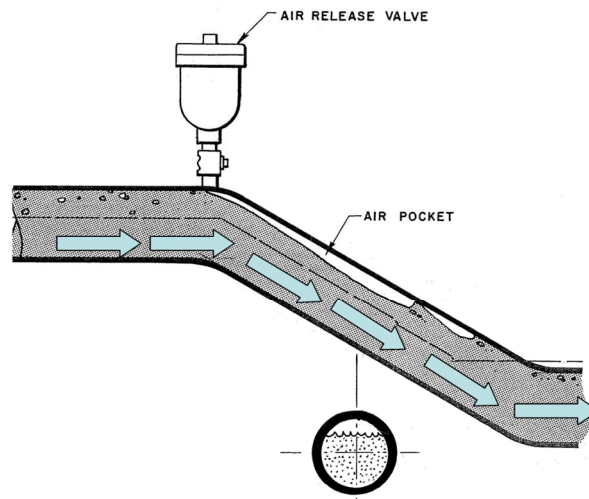

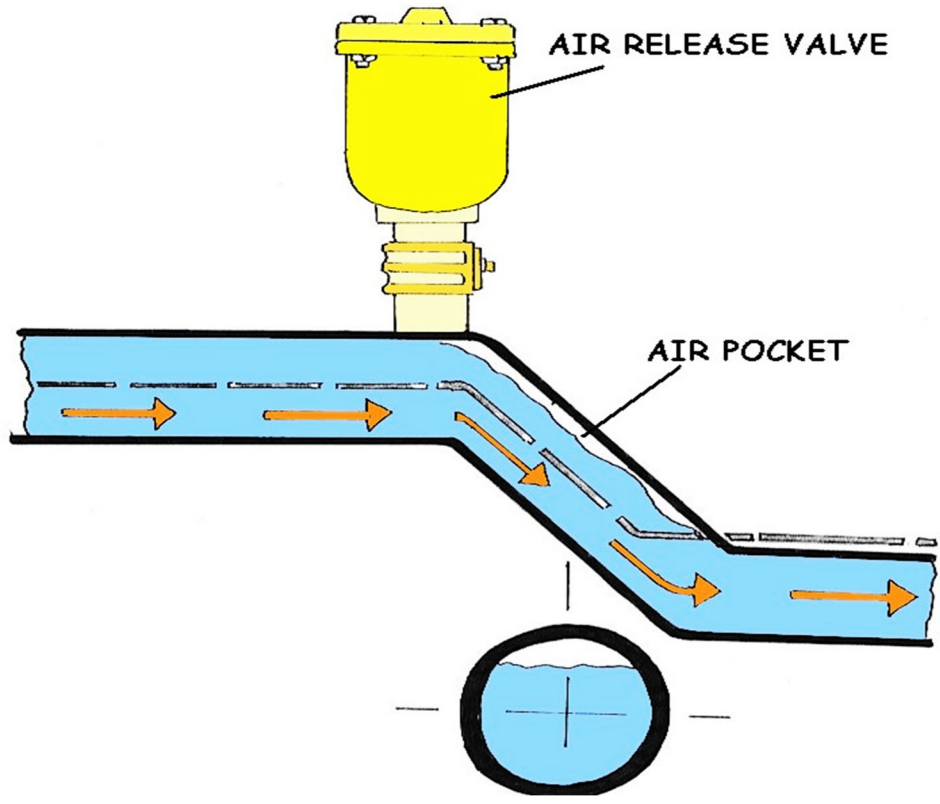
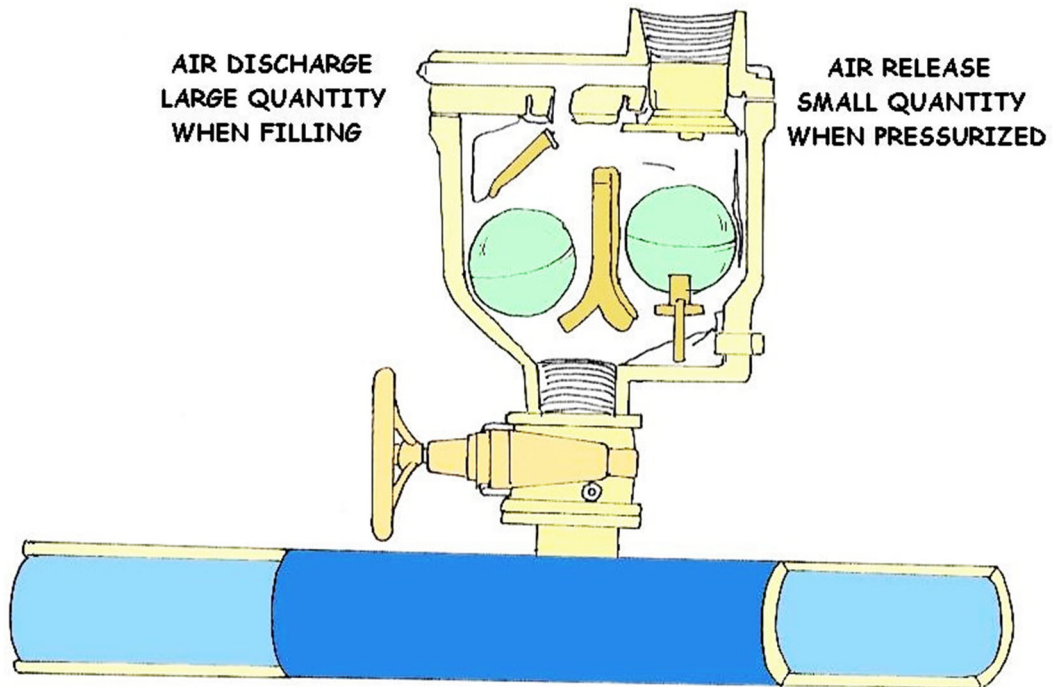

COMBINATION AIR RELIEF VALVE

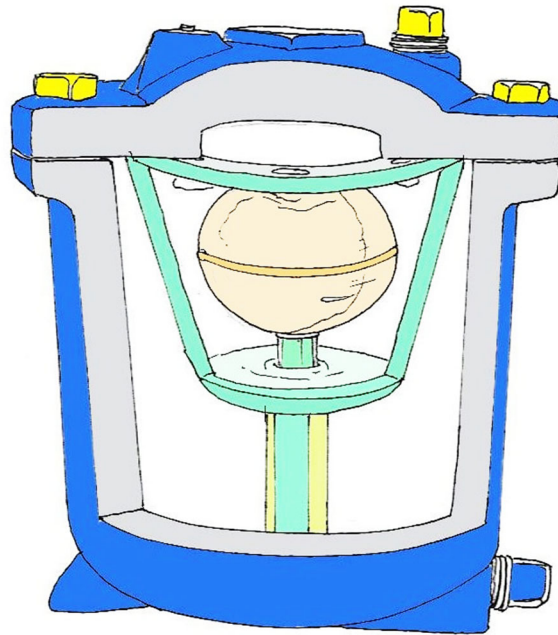

INTERNAL VIEW OF COMBINATION AIR VALVE

- Exhaust air as water fills the pipe; closes when the pipe is full and water enters the valve lifting the float against the seat.
- Does not reopen unless the line pressure falls below atmospheric pressure due to a line break or pipeline draining. The float drops and air is admitted into the pipe to minimize vacuum formation.
- The large size outlet orifice (normally equal to the inlet orifice) sized about $1/6^{\text{th}}$ to $1/8^{\text{th}}$ of the nominal pipe size to purge air and relieve vacuum.
- Locate at high points and between the pump and check valve.

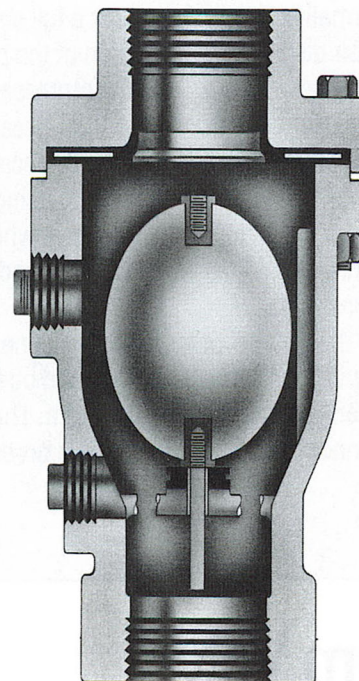

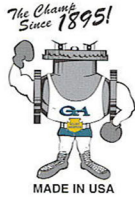

KINETIC vs. CONVENTIONAL COMBINATION AIR VALVES

KINETIC DESIGN

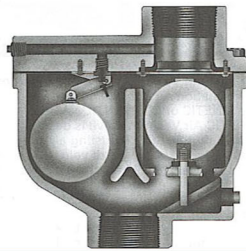

CONVENTIONAL DESIGN

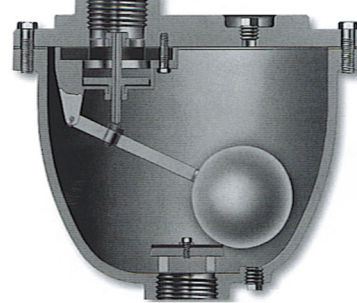

Size	Length	Width	Height	Weight
1"	6-1/4"	3-7/8"	7-1/4"	16 Lb
2"	9"	4-3/4"	9-3/8"	30 Lb
3"	12-3/8"	6-5/8"	12-1/4"	65 Lb
4"	15-1/4"	8-1/4"	13-1/4"	120 Lb

Size	Length	Width	Height	Weight
1"	11"	7"	10"	35 Lb
2"	14"	8"	12-1/4"	75 Lb
3"	16"	10"	15-1/2"	100 Lb
4"	18"	11"	17"	170 Lb

AIR/VACUUM BREAKING VALVES

SILENT CHECK TYPE

- Normally closed.
- Opens to admit air when pipe vacuum exceeds spring.
- Re-closes when pipe pressure returns to atmospheric.
- Can be supplied with small orifice for slow air release.

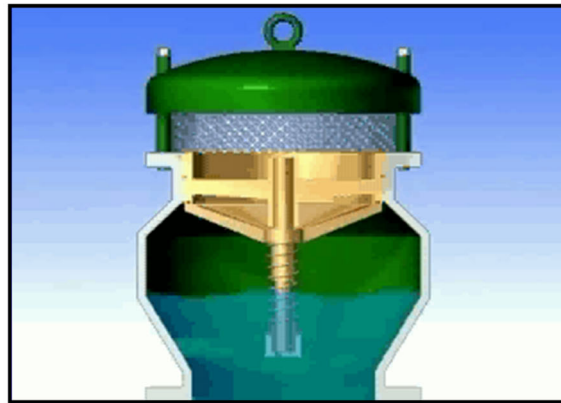

Pressure Reducing Valves - *Rotary Valve*

Pressure Relief Valve

Pressure relief valves are used to release excess pressure that may develop as a result of a sudden change in the velocity of the water flowing in the pipe.

PRVs assist in a variety of functions, from keeping system pressures safely below a desired upper limit to maintaining a set pressure in part of a circuit. Types include relief, reducing, sequence, counterbalance, and unloading. All of these are normally closed valves, except for reducing valves, which are normally open. For most of these valves, a restriction is necessary to produce the required pressure control. One exception is the externally piloted unloading valve, which depends on an external signal for its actuation.

The most practical components for maintaining secondary, lower pressure in a hydraulic system are pressure-reducing valves. Pressure-reducing valves are normally open, 2-way valves that close when subjected to sufficient downstream pressure. There are two types: direct acting and pilot operated.

Direct acting - A pressure-reducing valve limits the maximum pressure available in the secondary circuit regardless of pressure changes in the main circuit, as long as the work load generates no back flow into the reducing valve port, in which case the valve will close.

The pressure-sensing signal comes from the downstream side (secondary circuit). This valve, in effect, operates in reverse fashion from a relief valve (which senses pressure from the inlet and is normally closed). As pressure rises in the secondary circuit, hydraulic force acts on area A of the valve, closing it partly. Spring force opposes the hydraulic force, so that only enough oil flows past the valve to supply the secondary circuit at the desired pressure. The spring setting is adjustable.

When outlet pressure reaches that of the valve setting, the valve closes except for a small quantity of oil that bleeds from the low-pressure side of the valve, usually through an orifice in the spool, through the spring chamber, to the reservoir. Should the valve close fully, leakage past the spool could cause pressure build-up in the secondary circuit.

To avoid this, a bleed passage to the reservoir keeps it slightly open, preventing a rise in downstream pressure above the valve setting. The drain passage returns leakage flow to reservoir. (Valves with built-in relieving capability also are available to eliminate the need for this orifice.)

Constant and Fixed Pressure Reduction

Constant-pressure-reducing valves supply a preset pressure, regardless of main circuit pressure, as long as pressure in the main circuit is higher than that in the secondary. These valves balance secondary-circuit pressure against the force exerted by an adjustable spring which tries to open the valve. When pressure in the secondary circuit drops, spring force opens the valve enough to increase pressure and keep a constant reduced pressure in the secondary circuit. Fixed pressure reducing valves supply a fixed amount of pressure reduction regardless of the pressure in the main circuit. For instance, assume a valve is set to provide reduction of 250 psi.

If main system pressure is 2,750 psi, reduced pressure will be 2,500 psi; if main pressure is 2,000 psi, reduced pressure will be 1,750 psi. This valve operates by balancing the force exerted by the pressure in the main circuit against the sum of the forces exerted by secondary circuit pressure and the spring. Because the pressurized areas on both sides of the poppet are equal, the fixed reduction is that exerted by the spring.

How do Pressure Relief Valves Operate?

Most pressure relief valves consist of a main valve and pilot control system. The basic main Cla-Val valve is called a Hytrol Valve.

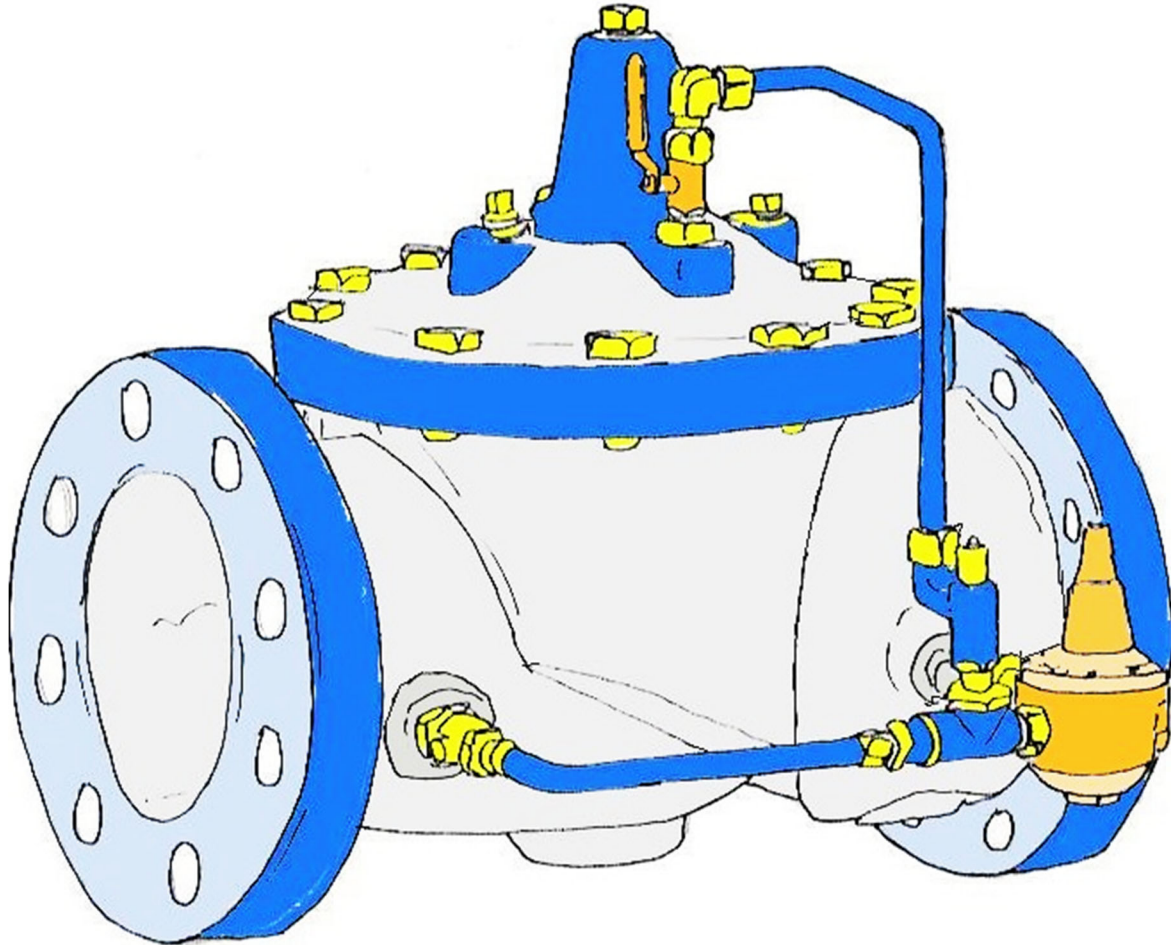

PRESSURE REDUCING VALVE EXAMPLE

When no pressure is in the valve, the spring and the weight of the diaphragm assembly holds the valve closed.

Often a small box can be connected to an existing pilot PRV valve to control the main Pressure Reducing Valve on the pipe network. This single box contains both the control electronics and an integral data logger to save the cost and space of having both a controller and a separate data logger. There are basically two types of PRV controllers, either time-based (to reduce the pipe pressure at low demand times, e.g. at night) or flow modulated controllers which can realize leakage savings throughout the day and night (by adjusting the pressure according to the demand to prevent excessive pressure at any time of the day or night).

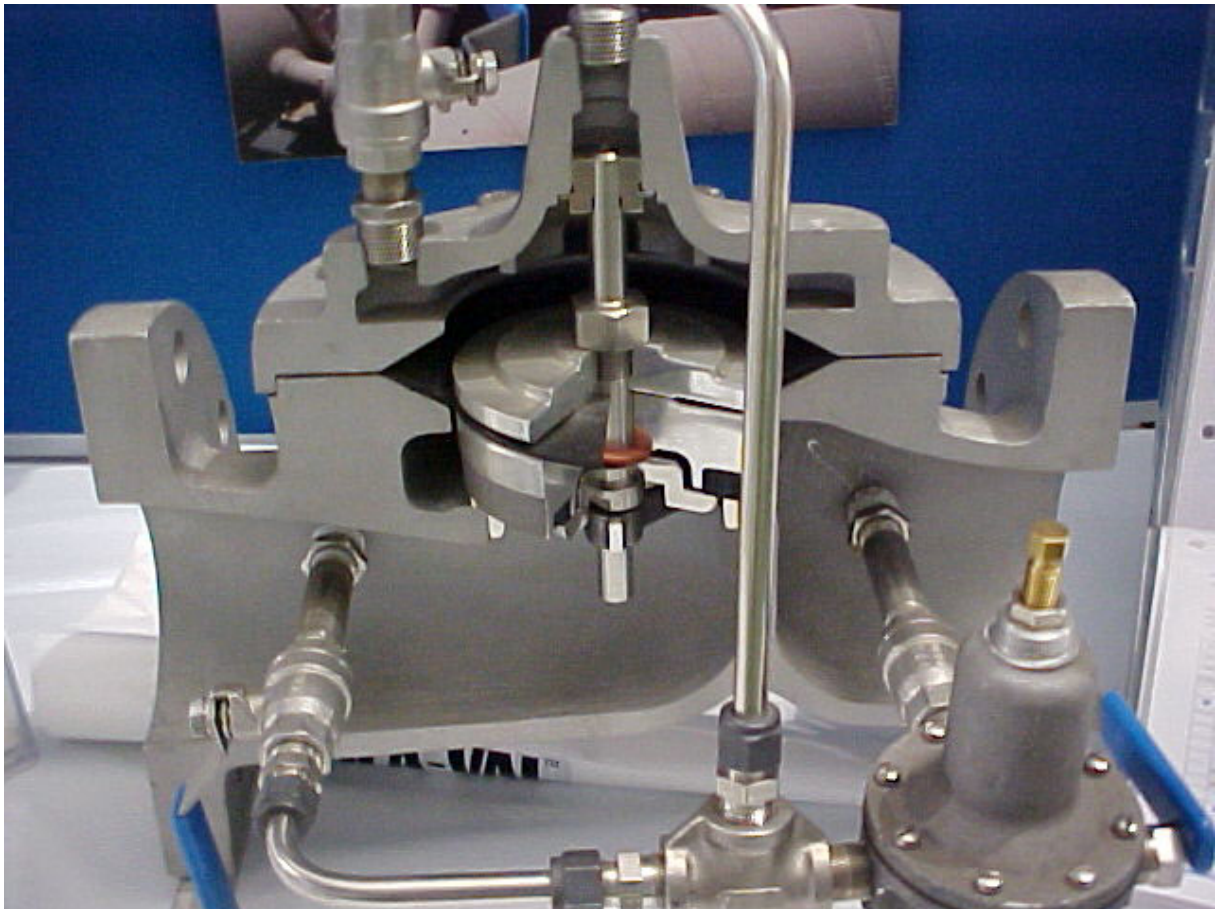

Municipal water distribution systems often have widely varying flow rates ranging from 7:00 am peak demand (or even fire-flow) to minimal 2:00am demand. One valve size cannot accurately control the wide range of flows.

A low flow bypass pressure reducing valve is often used to control pressure at the low flow conditions. Both valves are open at maximum flow demand. The small valve is set at a slightly higher pressure than the larger valve.

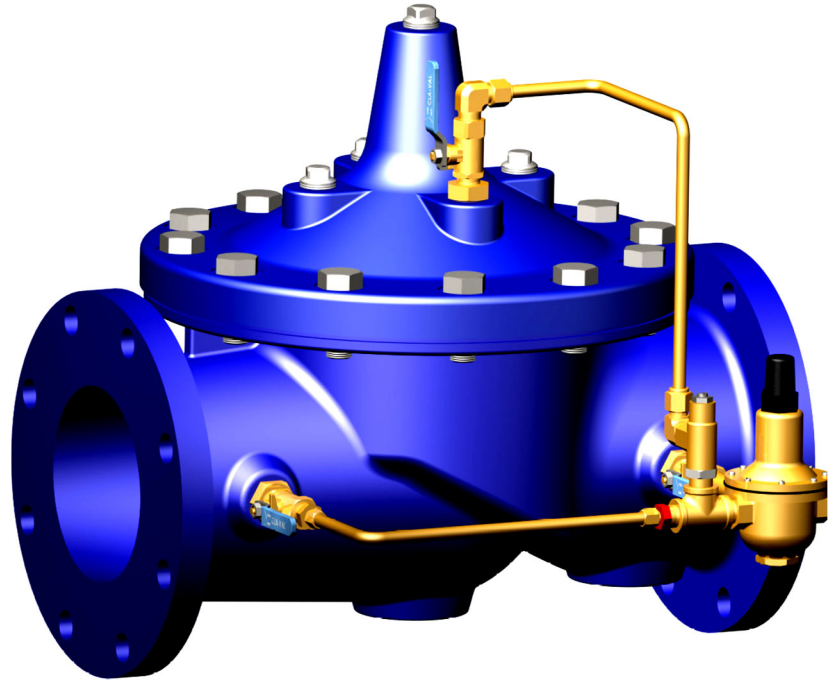

Pressure Reducing Valve

- Holds downstream pressure to a pre-determined limit.
- Optional check feature.
- Fully supported frictionless diaphragm.

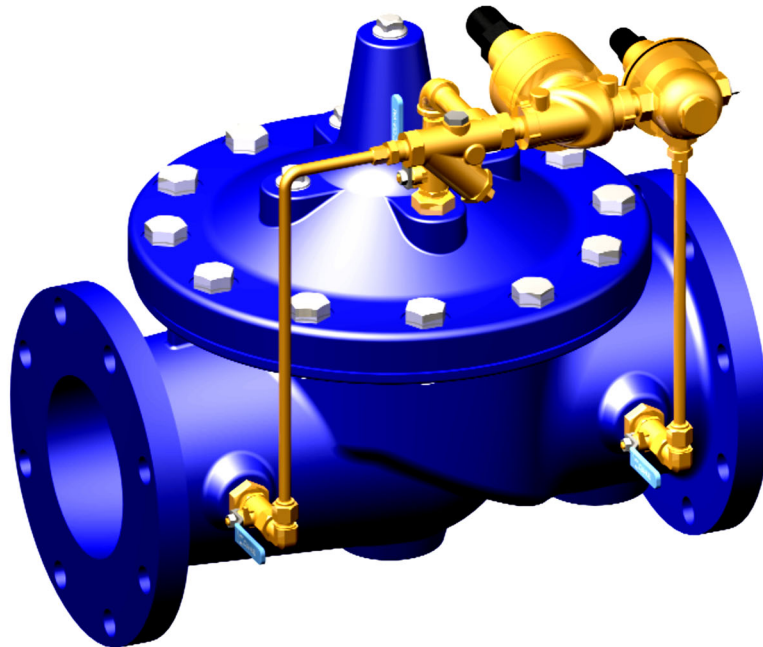

Pressure Reducing/Pressure Sustaining Control Valve

- Maintains downstream pressure regardless of fluctuating demand and sustains upstream pressure to a pre-set minimum.
- Optional check feature.

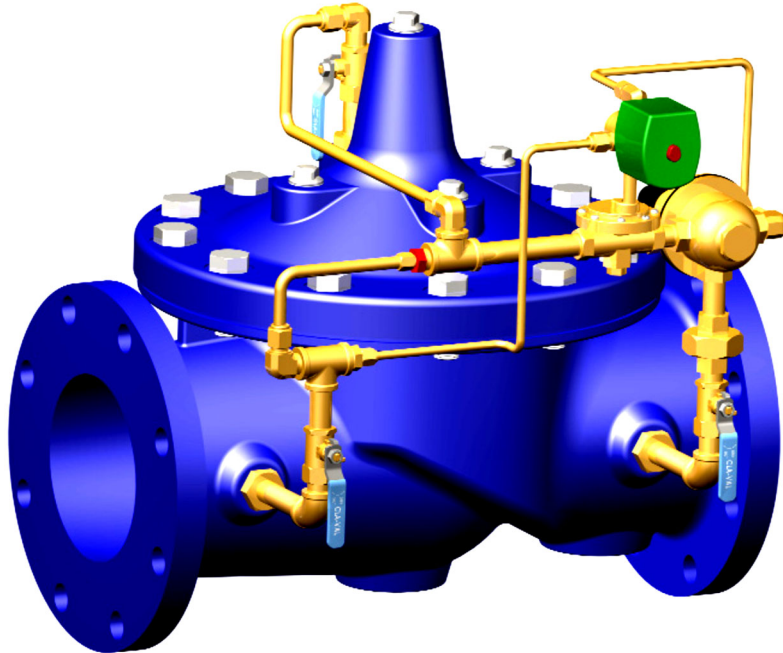

Pressure Reducing & Solenoid Shut-Off Valve Cla-Val 93 Series

- Ideal for reducing high transmission line pressures to lower distribution system pressures.
- Solenoid can be remotely activated.

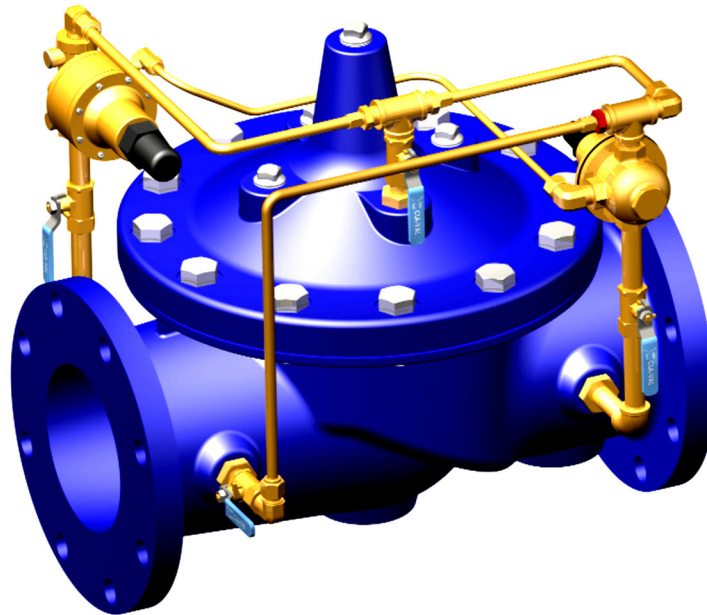

Pressure Reducing & Surge Control Valve Cla-Val 94 Series

- Integral surge pilot opens to prevent rapid pressure increases.
- Optional check feature.

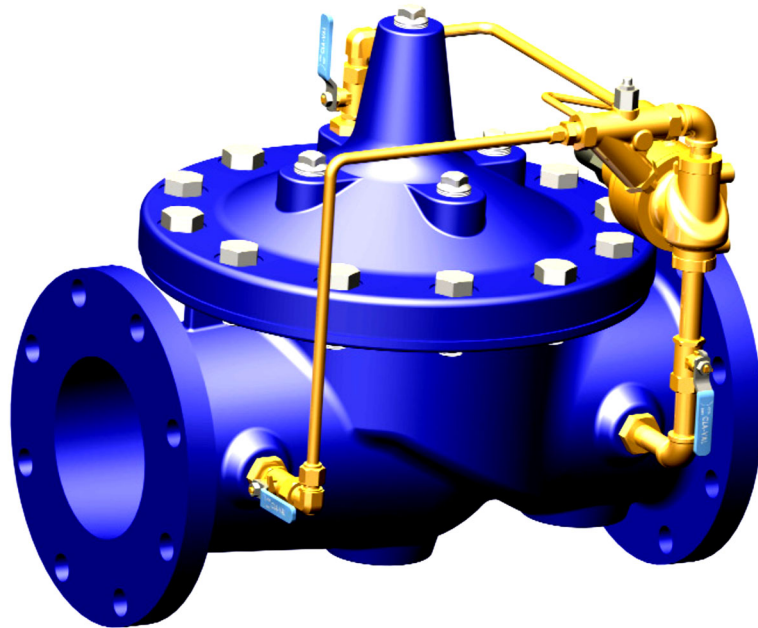

Pressure Relief/Pressure Sustaining Valve Cla-Val 50 Series

- Completely automatic operation.
- Accurate pressure control.
- Fast opening maintains line pressure.
- Slow closing prevents surges.
- Optional check feature.

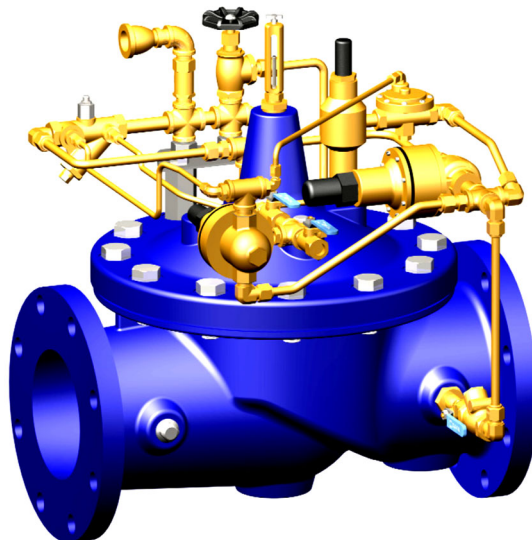

Surge Anticipator Valve Cla-Val 52 Series

- Protects pumping equipment and pipelines from damage caused by rapid flow velocity changes.
- Opens on initial low pressure wave.
- Closes slowly to prevent subsequent surges.



Float Valve Cla-Val 124 Series

- Accurate and repeatable level control in tanks to pre-set high and low points
- Reliable drip-tight shut-off.
- On-Off non-modulating action.
- Use Model 428-01 for modulating service.

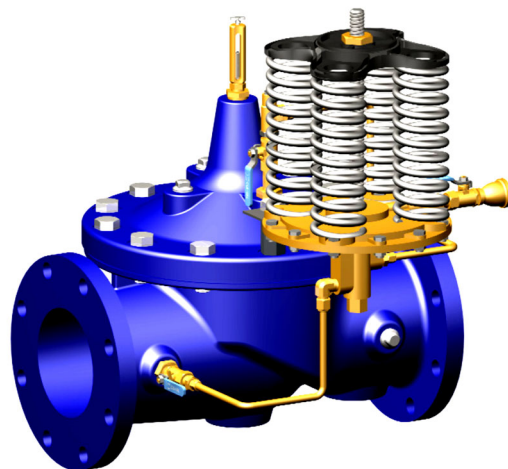

Altitude Control Valve Cla-Val 210 Series

- Provides accurate and repeatable tank level control.
- Optional check valve feature.
- Delayed opening option available.
- One-way and two-way flow pilot systems available.

Incoming pressure fluctuates between 100 to 130 psi

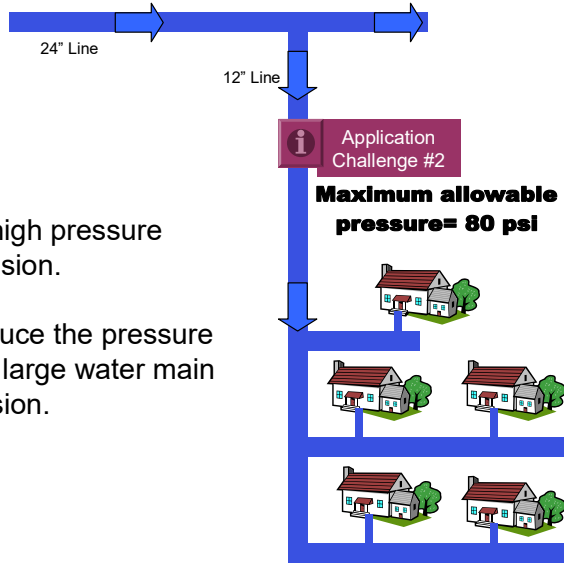

A small branch line tee's off a large high pressure water main to feed water to a subdivision.

Automatically (without electricity) reduce the pressure from a range of 100 to 130 psi in the large water main to not exceed 80 psi into the subdivision.

SOLUTION

A Pressure Reducing Valve will reduce a higher variable upstream pressure to a uniform maximum downstream pressure by throttling in response to changes in the downstream pressure which result from changes in flow demand.

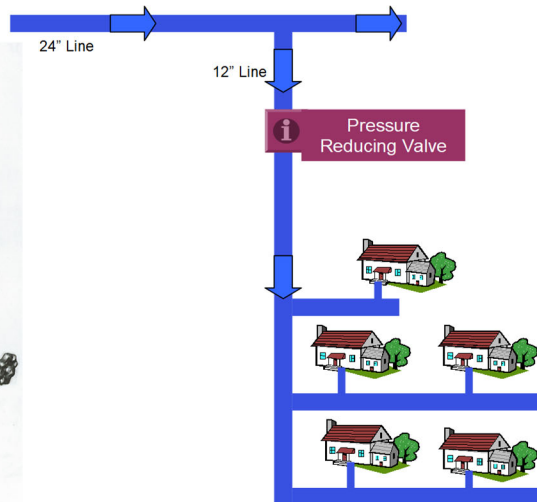
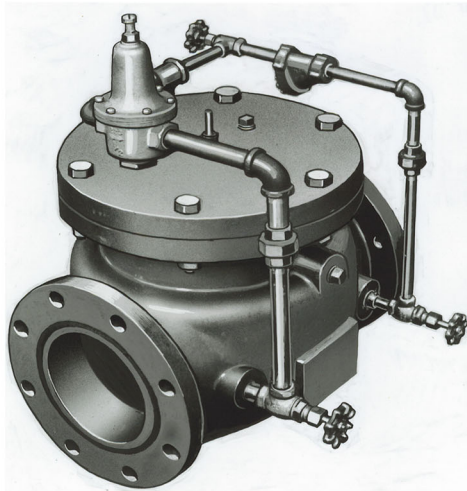

SERIES 2000 Features

1. Full-ported for high capacity
2. Stainless trim - Standard
3. Stainless steel vee-ports for precise low flow control
4. 1- 1/2" through 3" - Screwed NPT connections
2" through 12"- 125# Flanged connections
5. Globe or angle body, both use identical internal parts
6. Only one moving part
7. No rubber diaphragms to fatigue, rot, rupture or fail.
8. Drop-tight closure
9. Streamlined body for low inherent headloss
10. 100% tested for reliability
11. Easily maintained in the line
12. Many options available

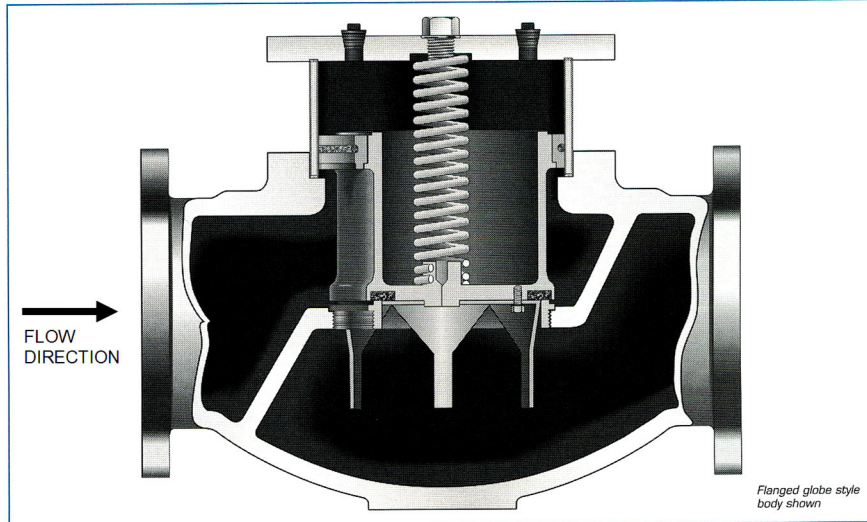

SERIES 2000 Features

1. Full-ported for high capacity
2. Stainless trim - Standard
3. Stainless steel vee-ports for precise low flow control
4. 1- 1/2" through 3" - Screwed NPT connections
2" through 12"- 125# Flanged connections
5. Globe or angle body, both use identical internal parts
6. Only one moving part
7. No rubber diaphragm to fatigue, rot, rupture or fail.
8. Drop-tight closure
9. Streamlined body for low inherent headloss
10. 100% tested for reliability
11. Easily maintained in the line
12. Many options available

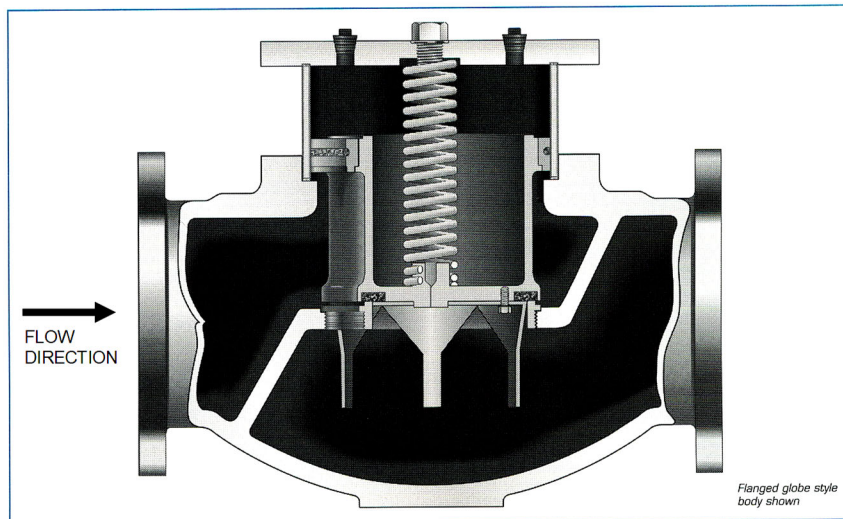

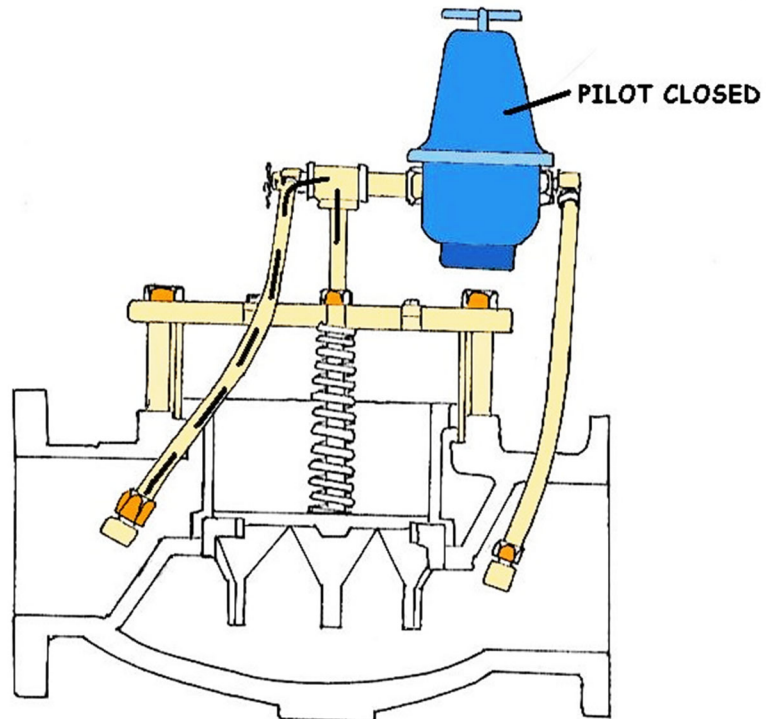

**REDUCED PRESSURE VALVE OPERATION
ABOVE – VALVE CLOSED, BELOW – VALVE OPENED**

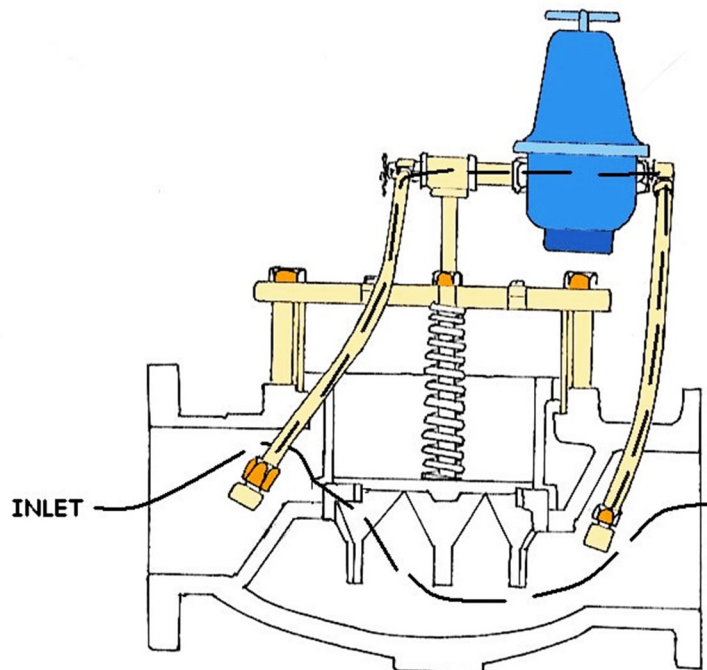

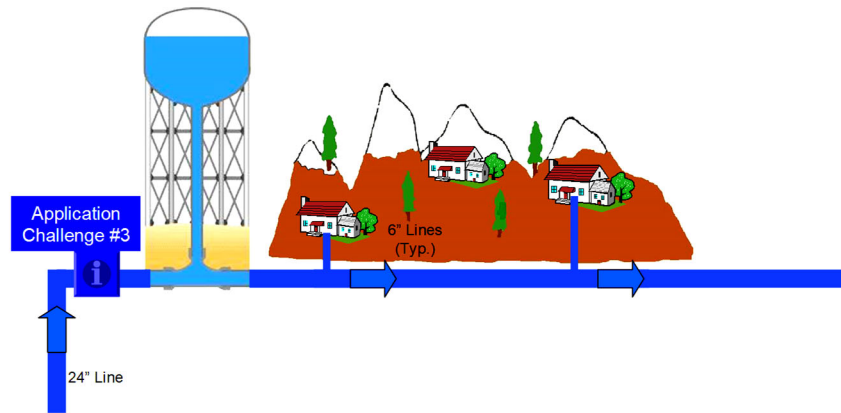

Automatically (and without electricity) control the water level in an elevated water storage tank, such that the tank does not overflow when completely filled and is automatically replenished as water is used from the tank.



Proposed Solution



This valve will:

1. Close on maximum tank level to prevent overflow.
2. Open when the tank head drops 6" to 12" to refill the tank.

Two different valve configurations:

1. Single Acting (Tank fill only)
2. Double Acting (Tank fill and drain)

COMMON ALTITUDE VALVE OPTIONS

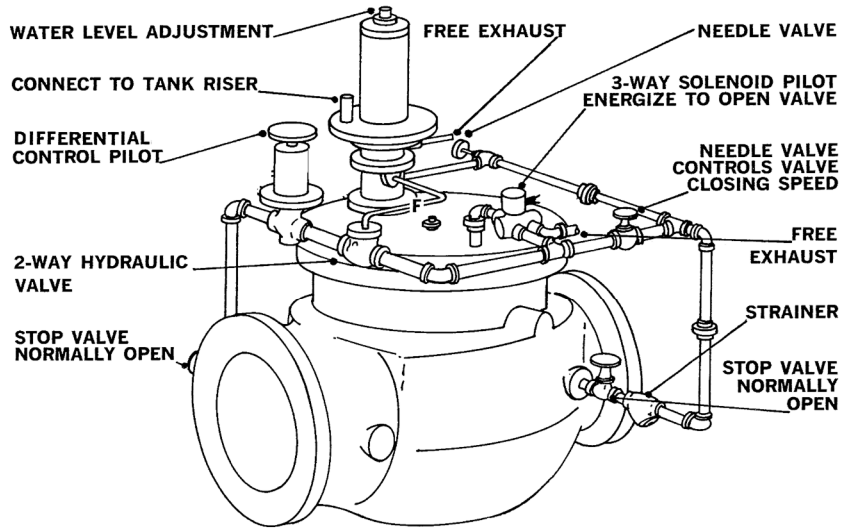

Solenoid Pilot- Provides remote override of the altitude pilot via an electrical switch control to open (or close) the main valve. Useful for diverting water from filling the tank to other demand, such as fire fighting



Differential Control Pilot- Allows tank level to drop several feet before refilling to prevent stale tank water.

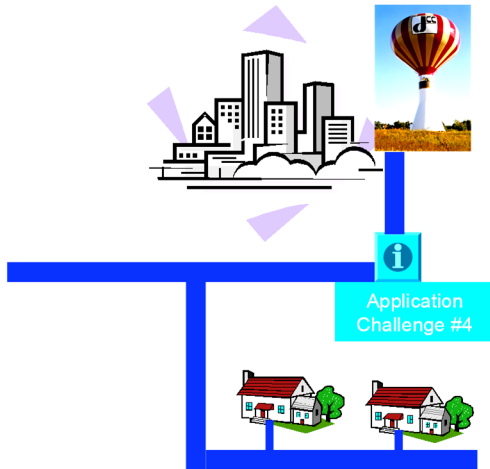

Provide water from a large municipality water system to the storage tank of a small town without overflowing the tank or exceeding the permitted flow rate.

Related In Plant Valves

COMMONLY USED PUMP CHECK VALVES

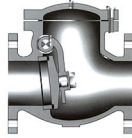

Plain Swing check valve



Lever and Spring Swing check valve



Lever and Weight Swing check valve

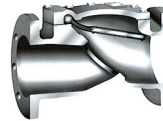

Rubber Flapper Swing check valve

Surge Relief valves are not usually employed due to short pipe runs in the plant.



A beautiful swing check valve. Swing checks need to be maintained. I hate finding a swing check that is both buried and forgotten, rusted in place or, my favorite, the check was removed.

Check Valves are not backflow preventors. The big difference is a legal term, "Backflow Prevention Assembly" that means two independent mechanical acting check valves with two independent shut offs which are checked annually by a certified general tester. We will explore the differences later. If I had to use a check valve, I would choose plastic and would check this device every six months because I don't trust them. Why? Because everything that is mechanical is subject to failure. Lots of nasties in the water, too. The bottom left photograph--a cut-away of a handsome spring loaded check valve. Right photograph--this looks like a check valve but really is a RP backflow preventor. Notice the smaller one in the background. Very bottom--A fireline check valve. This is probably the most political valve I can think of. Yes, I said political. Fire regulations are a whole new empire to work inside.



Valve Exercising Sub-Section

Valve exercising should be done once per year (especially main line valves) to detect malfunctioning valves and to prevent valves from becoming inoperable due to freezing or build-up of rust or corrosion. A valve inspection should include drawing valve location maps to show distances (ties) to the valves from specific reference points (telephone poles, stonelines, etc.).

Hydrants are designed to allow water from the distribution system to be used for fire-fighting purposes.

Bottom of a dry barrel fire hydrant--there is a drainage hole on the back of this hydrant, sometimes referred to as a "weep hole". Below is an "Airport Runway" type of hydrant. These are difficult to find.

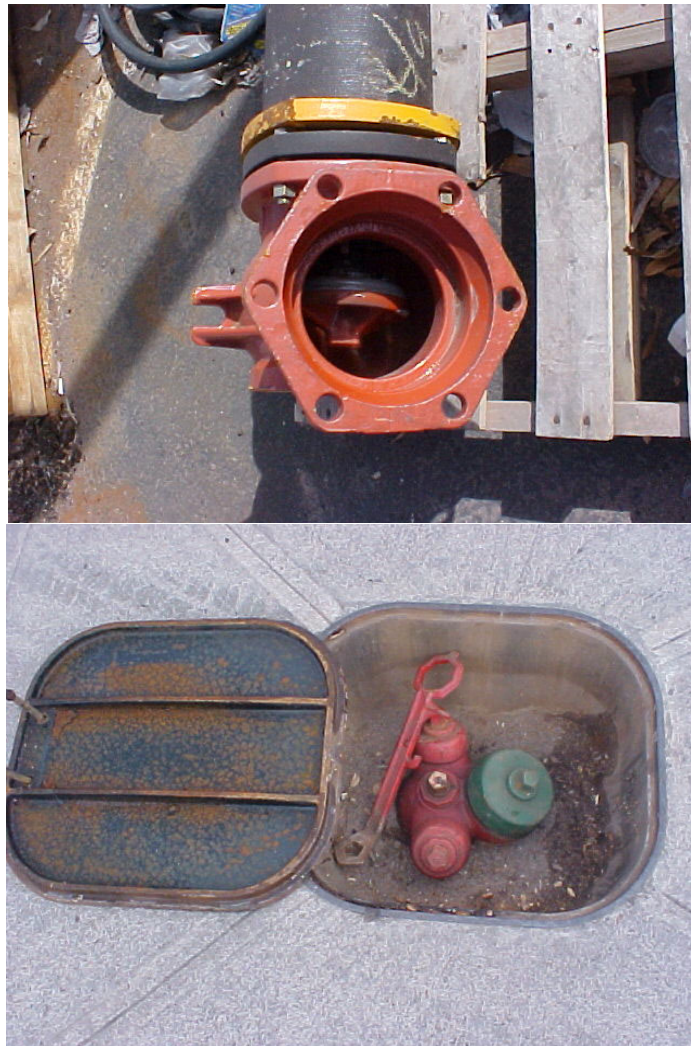

Here are Common Valve Operation Problems

Valve stem is improperly lubricated or damaged--I always like to find a bent brass stem. Just a small bend will make most valves difficult to operate. This also applies to misplaced valve boxes. It is best to disassemble the valve and inspect the stem. Acceptable deviation from theoretical centerline created by joining center points of the ends of the stem is 0.005"/ft of stem. Inspect the threads for any visible signs of damage. Small grooves less than 0.005" can be polished with an Emory cloth. Contact specialized services or an outside contractor if run-out is unacceptable or large grooves are discovered on the surface of the stem.

Valve packing compression is too tight--Verify the packing bolt torque and adjust if necessary.

Foreign debris is trapped on threads and/or in the packing area. This is a common problem when valves are installed outdoors in sandy areas and in areas not cleaned before operating. Always inspect threads and packing area for particle obstructions; even seemingly small amounts of sand trapped on the drive can completely stop large valves from cycling. The valve may stop abruptly when a cycle is attempted. With the line pressure removed from the valve, disconnect the actuator, gear operator or handwheel and inspect the drive nut, stem, bearings and yoke bushing.

Contaminated parts should be cleaned with a lint-free cloth using alcohol, varsol or equivalent. All parts should be re-lubricated before re-assembly. If the valves are installed outdoors in a sandy area, it may be desirable to cover the valves with jackets.

Valve components are faulty or damaged--If you suspect that the valve components are damaged or faulty, contact the supply house or warehouse. Most valve salesmen will try to keep your business and do whatever possible to do so. In the last ten years only one manufacturer did not replace a faulty valve. It is one of the largest makers of water valves and blew me off. It was clearly a bad valve to begin with. Sad part of this story is that the large American valve companies have to deal with aggressive Chinese valve companies that will make things right to keep your business. Most of these valves that I have seen are great for most water and wastewater work. They have nice finishes and even come in stainless steel--Probably made from recycled American cars. I just hate to switch over to anything other than American but I guess we are living in a Global market.

The handwheel is too small--Increasing the size of the handwheel will reduce the amount of torque required to operate the valve. If a larger handwheel is installed, the person operating the valve must be careful not to over-torque the valve when closing it. Most Valve operators will have a set of special keys for the operation of most valves but a small wheel can present problems as well as no hand wheel.

Dr. Rusty's commentary. Over the years and at most systems, it seems that the institutional knowledge that most of the old timers have is priceless and under appreciated by most management. The reason I say this is most experienced Valvemen or Valve Operators know their system better than any map or GIS system. Don't throw these people under the bus!

Slam, Surge and Water Hammer

When a valve is closed *instantaneously* there is a corresponding *instantaneous* pressure rise, causing a water hammer.

Water hammer (or, more generally, fluid hammer) is a pressure surge or wave caused by the kinetic energy of a fluid in motion when it is forced to stop or change direction suddenly. It depends on the fluid compressibility where there are sudden changes in pressure. For example, if a valve is closed suddenly at the end of a pipeline system a water hammer wave propagates in the pipe. Moving water in a pipe has kinetic energy proportional to the mass of the water in a given volume times the square of the velocity of the water.

The Effects of Water Hammer And Pulsations

Quick closing valves, positive displacement pumps, and vertical pipe runs can create damaging pressure spikes, leading to blown diaphragms, seals and gaskets, and also destroyed meters and gauges. Liquid, for all practical purposes, is not compressible; any energy that is applied to it is instantly transmitted. This energy becomes dynamic in nature when a force such as a quick closing valve or a pump applies velocity to the fluid.

Surge (Water Hammer)

Surge (or water hammer, as it is commonly known) is the result of a sudden change in liquid velocity. Water hammer usually occurs when a transfer system is quickly started, stopped or is forced to make a rapid change in direction. Any of these events can lead to catastrophic system component failure. Without question, the primary cause of water hammer in process applications is the quick closing valve, whether manual or automatic. A valve closing in 1.5 sec. or less depending upon valve size and system conditions causes an abrupt stoppage of flow. The pressure spike (acoustic wave) created at rapid valve closure can be high as five(5) times the system working pressure.

For this reason, most pipe-sizing charts recommend keeping the flow velocity at or below 5 ft/s (1.5 m/s). If the pipe is suddenly closed at the outlet (downstream), the mass of water before the closure is still moving forward with some velocity, building up a high pressure and shock waves. In domestic plumbing this is experienced as a loud bang resembling a hammering noise. Water hammer can cause pipelines to break or even explode if the pressure is high enough.

Air traps or stand pipes (open at the top) are sometimes added as dampers to water systems to provide a cushion to absorb the force of moving water in order to prevent damage to the system. (At some hydroelectric generating stations, what appears to be a water tower is actually one of these devices.) The water hammer principle can be used to create a simple water pump called a hydraulic ram.

On the other hand, when a valve in a pipe is closed, the water downstream of the valve will attempt to continue flowing, creating a vacuum that may cause the pipe to collapse or implode. This problem can be particularly acute if the pipe is on a downhill slope. To prevent this, air and vacuum relief valves, or air vents, are installed just downstream of the valve to allow air to enter the line and prevent this vacuum from occurring. Unrestricted, this pressure spike or wave will rapidly accelerate to the speed of sound in liquid, which can exceed 4000 ft/sec. It is possible to estimate the pressure increase by the following formula.

Water Hammer Formula: $P = (0.070) (V) (L) / t + P1$

Where P = Increase in pressure
P1 = Inlet Pressure
V = Flow velocity in ft/sec
t = Time in sec.(Valve closing time)
L = Upstream Pipe Length in feet

Here's an example of pressure hammer when closing an EASMT solenoid valve, with a 50 ft long upstream pipe connection:

L = 50 ft
V = 5.0 ft / sec(recommended velocity for PVC piping design)
t = 40 ms(solenoid valve closing time is approx. 40-50 ms)
P1 = 50 psi inlet pressure

therefore, $P = 0.07 \times 5 \times 50 / 0.040 + P1$
or $P = 437.5 \text{ psi} + P1$

Total Pressure = $437.5 + 50 = 487.5 \text{ psi}$

Pulsation

Pulsation generally occurs when a liquid's motive force is generated by reciprocating or peristaltic positive displacement pumps. It is most commonly caused by the acceleration and deceleration of the pumped fluid. This uncontrolled energy appears as pressure spikes.

Vibration is the visible example of pulsation and is the culprit that usually leads the way to component failure. Unlike centrifugal pumps (which produce normally non-damaging high-frequency but low-amplitude pulses), the amplitude is the problem because it's the pressure spike.

The peak, instantaneous pressure required to accelerate the liquid in the pipe line can be greater than ten (10) times the steady state flow pressure produced by a centrifugal pump. Damage to seals gauges, diaphragms, valves and joints in piping result from the pressure spikes created by the pulsating flow.

Remedy

Suggest that you install a pulsation dampener or surge tank. Dampeners provide the most cost efficient and effective choice to prevent the damaging effects of pulsation. A surge suppressor is in design essentially the same as pulsation dampener. The difference primarily lies in sizing and pressurizing.

The most current pulsation dampener design is the hydro-pneumatic dampener, consisting of a pressure vessel containing a compressed gas, generally air or Nitrogen separated from the process liquid by a bladder or diaphragm. The dampener is installed as close as possible to the pump or quick closing valve and is charged to 85% of the liquid line pressure. Proper sizing of the pulsation or surge suppressor requires several calculations.

Hydraulic Principles Section

Definition: **Hydraulics** is a branch of engineering concerned mainly with moving liquids. The term is applied commonly to the study of the mechanical properties of water, other liquids, and even gases when the effects of compressibility are small. Hydraulics can be divided into two areas, hydrostatics and hydrokinetics.

Hydraulics: *The Engineering science pertaining to liquid pressure and flow.*

The word **hydraulics** is based on the Greek word for water, and originally covered the study of the physical behavior of water at rest and in motion. Use has broadened its meaning to include the behavior of all liquids, although it is primarily concerned with the motion of liquids.

Hydraulics includes the manner in which liquids act in tanks and pipes, deals with their properties, and explores ways to take advantage of these properties.

Hydrostatics, the consideration of liquids at rest, involves problems of buoyancy and flotation, pressure on dams and submerged devices, and hydraulic presses. The relative incompressibility of liquids is one of its basic principles. Hydrodynamics, the study of liquids in motion, is concerned with such matters as friction and turbulence generated in pipes by flowing liquids, the flow of water over weirs and through nozzles, and the use of hydraulic pressure in machinery.

Hydrostatics

Hydrostatics is about the pressures exerted by a fluid at rest. Any fluid is meant, not just water. Research and careful study on water yields many useful results of its own, however, such as forces on dams, buoyancy and hydraulic actuation, and is well worth studying for such practical reasons. Hydrostatics is an excellent example of deductive mathematical physics, one that can be understood easily and completely from a very few fundamentals, and in which the predictions agree closely with experiment.

There are few better illustrations of the use of the integral calculus, as well as the principles of ordinary statics, available to the student. A great deal can be done with only elementary mathematics. Properly adapted, the material can be used from the earliest introduction of school science, giving an excellent example of a quantitative science with many possibilities for hands-on experiences.

The definition of a fluid deserves careful consideration. Although time is not a factor in hydrostatics, it enters in the approach to hydrostatic equilibrium. It is usually stated that a fluid is a substance that cannot resist a shearing stress, so that pressures are normal to confining surfaces.

Geology has now shown us clearly that there are substances which can resist shearing forces over short time intervals, and appear to be typical solids, but which flow like liquids over long time intervals. Such materials include wax and pitch, ice, and even rock.



A ball of pitch, which can be shattered by a hammer, will spread out and flow in months. Ice, a typical solid, will flow in a period of years, as shown in glaciers, and rock will flow over hundreds of years, as in convection in the mantle of the earth.

Shear earthquake waves, with periods of seconds, propagate deep in the earth, though the rock there can flow like a liquid when considered over centuries. The rate of shearing may not be strictly proportional to the stress, but exists even with low stress.

Viscosity may be the physical property that varies over the largest numerical range, competing with electrical resistivity. There are several familiar topics in hydrostatics which often appears in expositions of introductory science, and which are also of historical interest and can enliven their presentation. Let's start our study with the principles of our atmosphere.

Atmospheric Pressure

The atmosphere is the entire mass of air that surrounds the earth. While it extends upward for about 500 miles, the section of primary interest is the portion that rests on the earth's surface and extends upward for about 7 1/2 miles. This layer is called the troposphere.

If a column of air 1-inch square extending all the way to the "**top**" of the atmosphere could be weighed, this column of air would weigh approximately 14.7 pounds at sea level. Thus, atmospheric pressure at sea level is approximately 14.7 psi.

As one ascends, the atmospheric pressure decreases by approximately 1.0 psi for every 2,343 feet. However, below sea level, in excavations and depressions, atmospheric pressure increases. Pressures under water differ from those under air only because the weight of the water must be added to the pressure of the air.

Atmospheric pressure can be measured by any of several methods. The common laboratory method uses the mercury column barometer. The height of the mercury column serves as an indicator of atmospheric pressure. At sea level and at a temperature of 0° Celsius (**C**), the height of the mercury column is approximately 30 inches, or 76 centimeters. This represents a pressure of approximately 14.7 psi. The 30-inch column is used as a reference standard.

Another device used to measure atmospheric pressure is the aneroid barometer. The aneroid barometer uses the change in shape of an evacuated metal cell to measure variations in atmospheric pressure. The thin metal of the aneroid cell moves in or out with the variation of pressure on its external surface. This movement is transmitted through a system of levers to a pointer, which indicates the pressure.

The atmospheric pressure does not vary uniformly with altitude. It changes very rapidly. Atmospheric pressure is defined as the force per unit area exerted against a surface by the weight of the air above that surface.

In the diagram on the following page, the pressure at point "**X**" increases as the weight of the air above it increases. The same can be said about decreasing pressure, where the pressure at point "**X**" decreases if the weight of the air above it also decreases.

Top of the Atmosphere

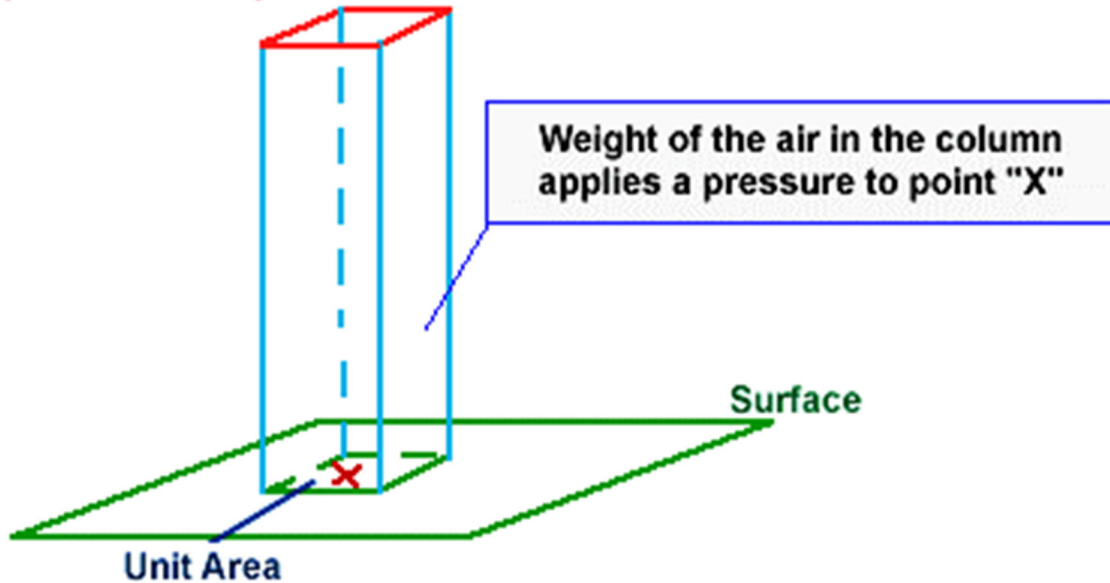

Barometric Loop

The barometric loop consists of a continuous section of supply piping that abruptly rises to a height of approximately 35 feet and then returns back down to the originating level. It is a loop in the piping system that effectively protects against backsiphonage. It may not be used to protect against back-pressure.

Its operation, in the protection against backsiphonage, is based upon the principle that a water column, at sea level pressure, will not rise above 33.9 feet. In general, barometric loops are locally fabricated, and are 35 feet high.

Pressure may be referred to using an absolute scale, pounds per square inch absolute (**psia**), or gauge scale, (**psiag**). Absolute pressure and gauge pressure are related.

Absolute pressure is equal to gauge pressure plus the atmospheric pressure. At sea level, the atmospheric pressure is 14.7 psia.

Absolute pressure is the total pressure. Gauge pressure is simply the pressure read on the gauge.

If there is no pressure on the gauge other than atmospheric, the gauge will read zero. Then the absolute pressure would be equal to 14.7 psi, which is the atmospheric pressure.

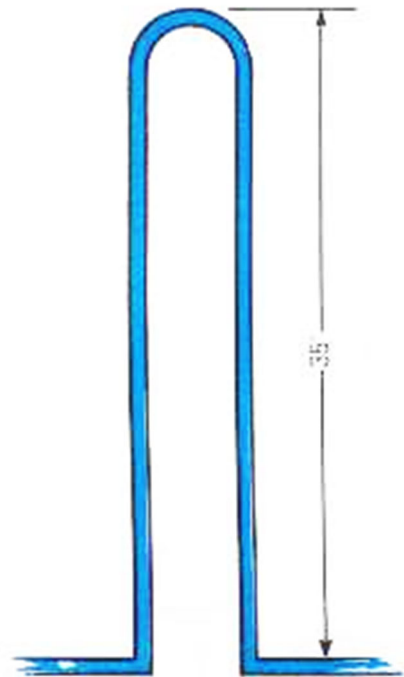

Pressure

By a fluid, we have a material in mind like water or air, two very common and important fluids. Water is incompressible, while air is very compressible, but both are fluids. Water has a definite volume; air does not. Water and air have low viscosity; that is, layers of them slide very easily on one another, and they quickly assume their permanent shapes when disturbed by rapid flows. Other fluids, such as molasses, may have high viscosity and take a long time to come to equilibrium, but they are no less fluids. The coefficient of viscosity is the ratio of the shearing force to the velocity gradient. Hydrostatics deals with permanent, time-independent states of fluids, so viscosity does not appear, except as discussed in the Introduction.

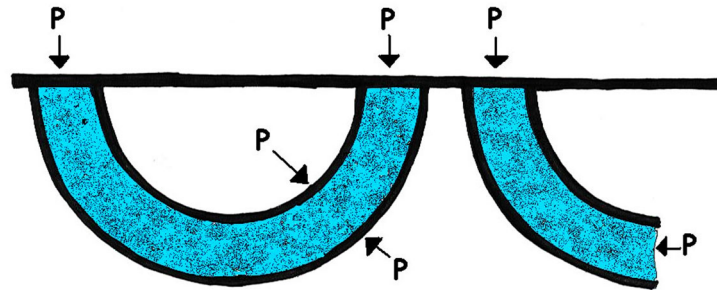

EQUALITY OF PRESSURE – CURTAIN RINGS

A fluid, therefore, is a substance that cannot exert any permanent forces tangential to a boundary. Any force that it exerts on a boundary must be normal to the boundary. Such a force is proportional to the area on which it is exerted, and is called a pressure. We can imagine any surface in a fluid as dividing the fluid into parts pressing on each other, as if it were a thin material membrane, and so think of the pressure at any point in the fluid, not just at the boundaries. In order for any small element of the fluid to be in equilibrium, the pressure must be the same in all directions (or the element would move in the direction of least pressure), and if no other forces are acting on the body of the fluid, the pressure must be the same at all neighboring points.

Therefore, in this case the pressure will be the same throughout the fluid, and the same in any direction at a point (Pascal's Principle). Pressure is expressed in units of force per unit area such as dyne/cm², N/cm² (pascal), pounds/in² (psi) or pounds/ft² (psf). The axiom that if a certain volume of fluid were somehow made solid, the equilibrium of forces would not be disturbed, is useful in reasoning about forces in fluids.

On earth, fluids are also subject to the force of gravity, which acts vertically downward, and has a magnitude $\gamma = \rho g$ per unit volume, where g is the acceleration of gravity, approximately 981 cm/s² or 32.15 ft/s², ρ is the density, the mass per unit volume, expressed in g/cm³, kg/m³, or slug/ft³, and γ is the specific weight, measured in lb/in³, or lb/ft³ (pcf). Gravitation is an example of a body force that disturbs the equality of pressure in a fluid. The presence of the gravitational body force causes the pressure to increase with depth, according to the equation $dp = \rho g dh$, in order to support the water above. We call this relation the barometric equation, for when this equation is integrated, we find the variation of pressure with height or depth. If the fluid is incompressible, the equation can be integrated at once, and the pressure as a function of depth h is $p = \rho gh + p_0$.

The density of water is about 1 g/cm^3 , or its specific weight is 62.4 pcf. We may ask what depth of water gives the normal sea-level atmospheric pressure of 14.7 psi, or 2117 psf.

This is simply $2117 / 62.4 = 33.9 \text{ ft}$ of water. This is the maximum height to which water can be raised by a suction pump, or, more correctly, can be supported by atmospheric pressure. Professor James Thomson (brother of William Thomson, Lord Kelvin) illustrated the equality of pressure by a "curtain-ring" analogy shown in the diagram. A section of the toroid was identified, imagined to be solidified, and its equilibrium was analyzed.

The forces exerted on the curved surfaces have no component along the normal to a plane section, so the pressures at any two points of a plane must be equal, since the fluid represented by the curtain ring was in equilibrium.

The diagram illustrates the equality of pressures in orthogonal directions. This can be extended to any direction whatever, so Pascal's Principle is established. This demonstration is similar to the usual one using a triangular prism and considering the forces on the end and lateral faces separately.

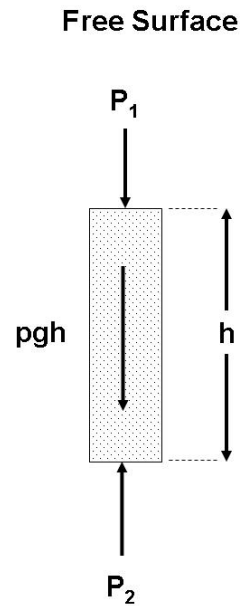

Increase of Pressure with Depth

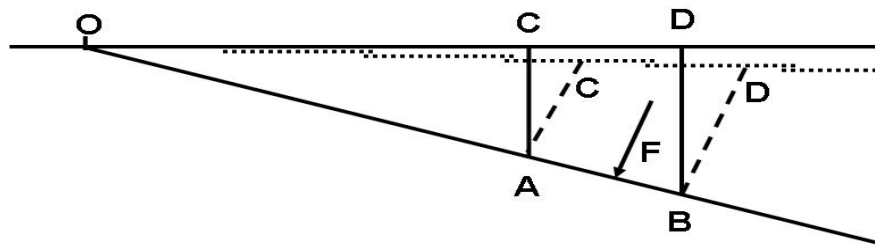

THRUST ON A PLANE

Free Surface Perpendicular to Gravity

When gravity acts, the liquid assumes a free surface perpendicular to gravity, which can be proved by Thomson's method. A straight cylinder of unit cross-sectional area (assumed only for ease in the arithmetic) can be used to find the increase of pressure with depth. Indeed, we see that $p_2 = p_1 + \rho gh$. The upper surface of the cylinder can be placed at the free surface if desired. The pressure is now the same in any direction at a point, but is greater at points that lie deeper. From this same figure, it is easy to prove Archimedes' Principle that the buoyant force is equal to the weight of the displaced fluid, and passes through the center of mass of this displaced fluid.

Geometric Arguments

Ingenious geometric arguments can be used to substitute for easier, but less transparent arguments using calculus. For example, the force acting on one side of an inclined plane surface whose projection is AB can be found as in the diagram on previous page. O is the point at which the prolonged projection intersects the free surface. The line AC' perpendicular to the plane is made equal to the depth AC of point A, and line BD' is similarly drawn equal to BD. The line OD' also passes through C', by proportionality of triangles OAC' and OAD'.

Therefore, the thrust F on the plane is the weight of a prism of fluid of cross-section AC'D'B, passing through its centroid normal to plane AB. Note that the thrust is equal to the density times the area times the depth of the center of the area; its line of action does not pass through the center, but below it, at the center of thrust. The same result can be obtained with calculus by summing the pressures and the moments.

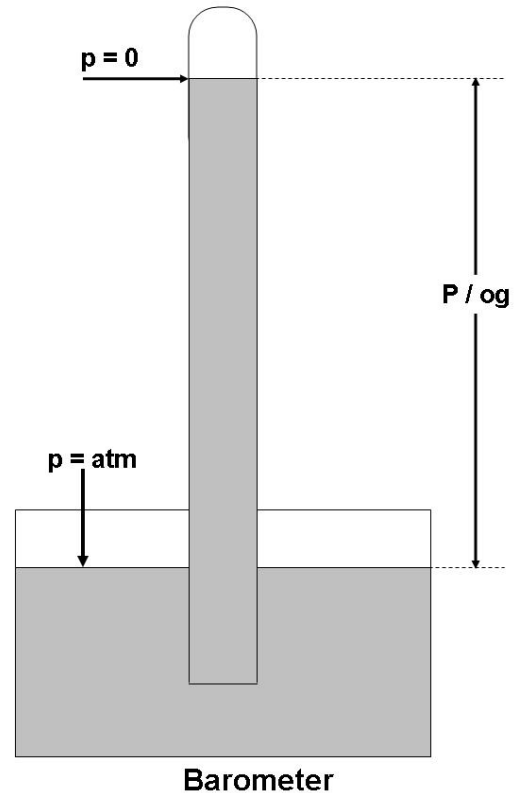

Atmospheric Pressure and its Effects

Suppose a vertical pipe is stood in a pool of water, and a vacuum pump applied to the upper end. Before we start the pump, the water levels outside and inside the pipe are equal, and the pressures on the surfaces are also equal and are equal to the atmospheric pressure.

Now start the pump. When it has sucked all the air out above the water, the pressure on the surface of the water inside the pipe is zero, and the pressure at the level of the water on the outside of the pipe is still the atmospheric pressure. Of course, there is the vapor pressure of the water to worry about if you want to be precise, but we neglect this complication in making our point. We require a column of water 33.9 ft high inside the pipe, with a vacuum above it, to balance the atmospheric pressure. Now do the same thing with liquid mercury, whose density at 0 °C is 13.5951 times that of water. The height of the column is 2.494 ft, 29.92 in, or 760.0 mm.

Standard Atmospheric Pressure

This definition of the standard atmospheric pressure was established by Regnault in the mid-19th century. In Britain, 30 in. Hg (inches of mercury) had been used previously. As a practical matter, it is convenient to measure pressure differences by measuring the height of liquid columns, a practice known as manometry. The barometer is a familiar example of this, and atmospheric pressures are traditionally given in terms of the length of a mercury column. To make a barometer, the barometric tube, closed at one end, is filled with mercury and then inverted and placed in a mercury reservoir. Corrections must be made for temperature, because the density of mercury depends on the temperature, and the brass scale expands for capillarity if the tube is less than about 1 cm in diameter, and even slightly for altitude, since the value of g changes with altitude. The vapor pressure of mercury is only 0.001201 mmHg at 20°C, so a correction from this source is negligible. For the usual case of a mercury column ($\alpha = 0.000181792$ per °C) and a brass scale ($\alpha = 0.0000184$ per °C) the temperature correction is -2.74 mm at 760 mm and 20°C. Before reading the barometer scale, the mercury reservoir is raised or lowered until the surface of the mercury just touches a reference point, which is mirrored in the surface so it is easy to determine the proper position.

An aneroid barometer uses a partially evacuated chamber of thin metal that expands and contracts according to the external pressure. This movement is communicated to a needle that revolves in a dial. The materials and construction are arranged to give a low temperature coefficient. The instrument must be calibrated before use, and is usually arranged to read directly in elevations.

An aneroid barometer is much easier to use in field observations, such as in reconnaissance surveys. In a particular case, it would be read at the start of the day at the base camp, at various points in the vicinity, and then finally at the starting point, to determine the change in pressure with time. The height differences can be calculated from $h = 60,360 \log(P/p) [1 + (T + t - 64)/986]$ feet, where P and p are in the same units, and T , t are in °F.

An absolute pressure is referring to a vacuum, while a gauge pressure is referring to the atmospheric pressure at the moment. A negative gauge pressure is a (partial) vacuum. When a vacuum is stated to be so many inches, this means the pressure below the atmospheric pressure of about 30 in. A vacuum of 25 inches is the same thing as an absolute pressure of 5 inches (of mercury).

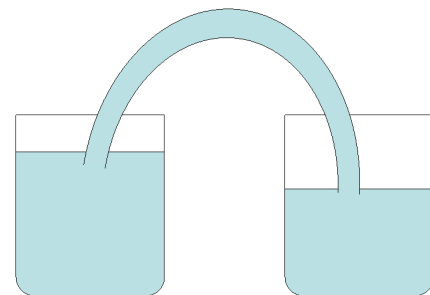

Siphon

Vacuum

The term **vacuum** indicates that the absolute pressure is less than the atmospheric pressure and that the gauge pressure is negative. A complete or total vacuum would mean a pressure of 0 psia or -14.7 psig. Since it is impossible to produce a total vacuum, the term vacuum, as used in this document, will mean all degrees of partial vacuum. In a partial vacuum, the pressure would range from slightly less than 14.7 psia (0 psig) to slightly greater than 0 psia (-14.7 psig).

Backsiphonage results from atmospheric pressure exerted on a liquid, forcing it toward a supply system that is under a vacuum.

Water Pressure

The weight of a cubic foot of water is 62.4 pounds per square foot. The base can be subdivided into 144-square inches with each subdivision being subjected to a pressure of 0.433 psig. Suppose you placed another cubic foot of water on top of the first cubic foot. The pressure on the top surface of the first cube which was originally atmospheric, or 0 psig, would now be 0.4333 psig as a result of the additional cubic foot of water. The pressure of the base of the first cubic foot would be increased by the same amount of 0.866 psig or two times the original pressure.

Pressures are very frequently stated in terms of the height of a fluid. If it is the same fluid whose pressure is being given, it is usually called "head," and the factor connecting the head and the pressure is the weight density ρg . In the English engineer's system, weight density is in pounds per cubic inch or cubic foot. A head of 10 ft is equivalent to a pressure of 624 psf, or 4.33 psi. It can also be considered an energy availability of ft-lb per lb. Water with a pressure head of 10 ft can furnish the same energy as an equal amount of water raised by 10 ft. Water flowing in a pipe is subject to head loss because of friction.

Take a jar and a basin of water. Fill the jar with water and invert it under the water in the basin. Now raise the jar as far as you can without allowing its mouth to come above the water surface. It is always a little surprising to see that the jar does not empty itself, but the water remains with no visible means of support. By blowing through a straw, one can put air into the jar, and as much water leaves as air enters. In fact, this is a famous method of collecting insoluble gases in the chemical laboratory, or for supplying hummingbird feeders. It is good to remind oneself of exactly the balance of forces involved.

Another application of pressure is the siphon. The name is Greek for the tube that was used for drawing wine from a cask. This is a tube filled with fluid connecting two containers of fluid, normally rising higher than the water levels in the two containers, at least to pass over their rims. In the diagram, the two water levels are the same, so there will be no flow. When a siphon goes below the free water levels, it is called an inverted siphon. If the levels in the two basins are not equal, fluid flows from the basin with the higher level into the one with the lower level, until the levels are equal.

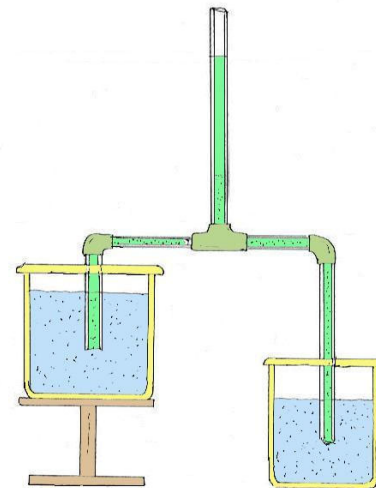

PASCAL'S SIPHON

A siphon can be made by filling the tube, closing the ends, and then putting the ends under the surface on both sides. Alternatively, the tube can be placed in one fluid and filled by sucking on it. When it is full, the other end is put in place. The analysis of the siphon is easy, and should be obvious. The pressure rises or falls as described by the barometric equation through the siphon tube.

There is obviously a maximum height for the siphon which is the same as the limit of the suction pump, about 34 feet. Inverted siphons are sometimes used in pipelines to cross valleys. Differences in elevation are usually too great to use regular siphons to cross hills, so the fluids must be pressurized by pumps so the pressure does not fall to zero at the crests.

Liquids at Rest

In studying fluids at rest, we are concerned with the transmission of force and the factors which affect the forces in liquids. Additionally, pressure in and on liquids and factors affecting pressure are of great importance.

Pressure and Force

Pressure is the force that pushes water through pipes. Water pressure determines the flow of water from the tap. If pressure is not sufficient then the flow can reduce to a trickle and it will take a long time to fill a kettle or a cistern.

The terms **force** and **pressure** are used extensively in the study of fluid power. It is essential that we distinguish between the terms.

Force means a total push or pull. It is the push or pull exerted against the total area of a particular surface and is expressed in pounds or grams. Pressure means the amount of push or pull (force) applied to each unit area of the surface and is expressed in pounds per square inch (lb/in²) or grams per square centimeter (gm/cm²). Pressure maybe exerted in one direction, in several directions, or in all directions.

Computing Force, Pressure, and Area

A formula is used in computing force, pressure, and area in fluid power systems. In this formula, P refers to pressure, F indicates force, and A represents area. Force equals pressure times area. Thus, the formula is written:

$$A = \frac{F}{P}$$

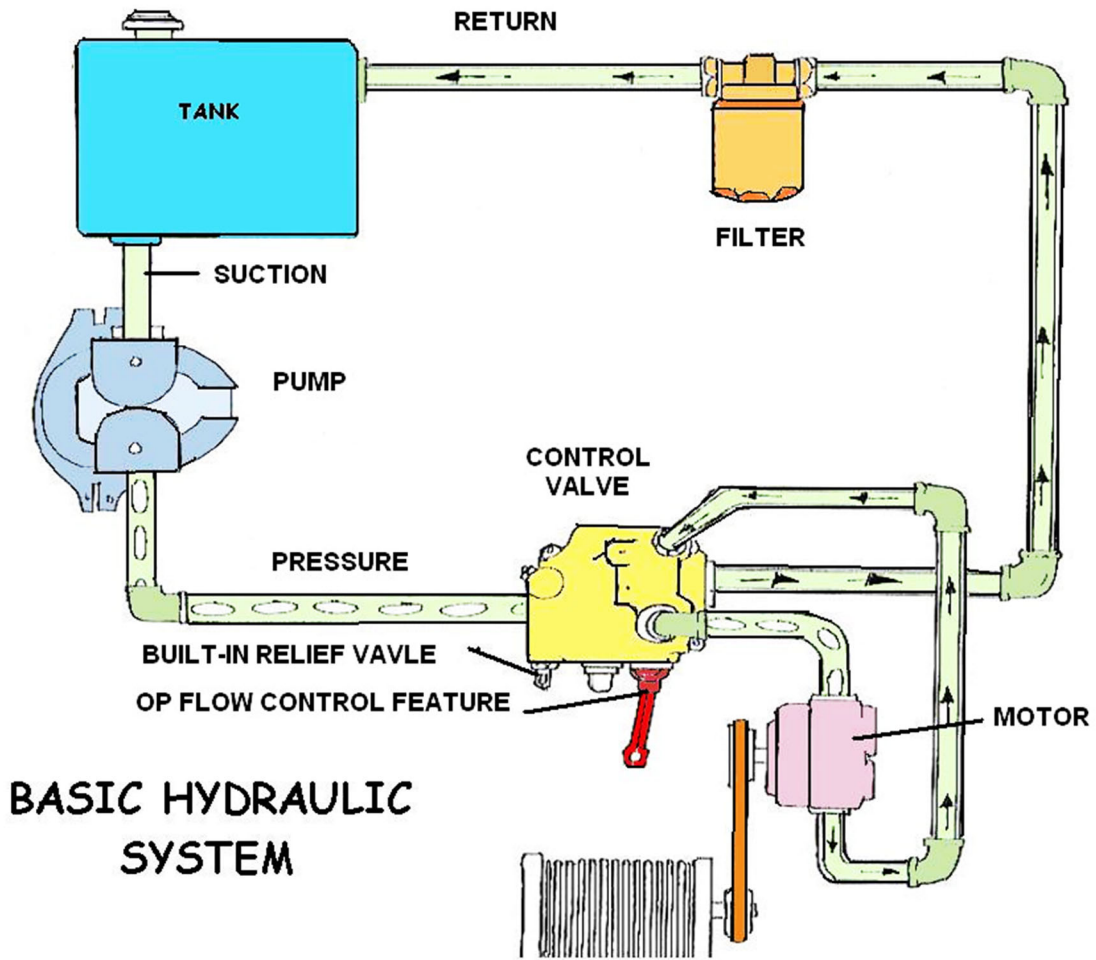

BASIC HYDRAULIC SYSTEM

Archimedes



ARCHIMEDES

Archimedes

Born	About 287 BC in Syracuse, Sicily. At the time, Syracuse was an independent Greek city-state with a 500-year history.
Died	212 or 211 BC in Syracuse when it was being sacked by a Roman army. He was killed by a Roman soldier who did not know who he was.
Education	Probably studied in Alexandria, Egypt, under the followers of Euclid.
Family	His father was an astronomer named Phidias and he was probably related to Hieron II, the king of Syracuse. It is not known whether he was married or had any children.
Inventions	Many war machines used in the defense of Syracuse, compound pulley systems, planetarium, water screw (possibly), water organ (possibly), burning mirrors (very unlikely).
Fields of Science Initiated	Hydrostatics, static mechanics, pycnometry (the measurement of the volume or density of an object). He is called the "father of integral calculus" and also the "father of mathematical physics".
Major Writings	On plane equilibriums, Quadrature of the parabola, On the sphere and cylinder, On spirals, On conoids and spheroids, On floating bodies, Measurement of a circle, The Sandreckoner, On the method of mechanical problems.
Place in History	Generally regarded as the greatest mathematician and scientist of antiquity and one of the three greatest mathematicians of all time (together with Isaac Newton (English 1643-1727) and Carl Friedrich Gauss (German 1777-1855)).

Archimedes was a great mathematician of ancient times. His greatest contributions were in geometry. He also spent some time in Egypt, where he invented the machine now called Archimedes' screw, which was a mechanical water pump. Among his most famous works is *Measurement of the Circle*, where he determined the exact value of pi between the two fractions, $3 \frac{10}{71}$ and $3 \frac{1}{7}$. He got this information by inscribing and circumscribing a circle with a 96-sided regular polygon.

Archimedes made many contributions to geometry in his work in the areas of plane figures and in the areas of area and volumes of curved surfaces. His methods started the idea for calculus which was "invented" 2,000 years later by Sir Isaac Newton and Gottfried Wilhelm von Leibniz. Archimedes proved that the volume of an inscribed sphere is two-thirds the volume of a circumscribed cylinder. He requested that this formula/diagram be inscribed on his tomb.

His works (that survived) include:

- Measurement of a Circle
- On the Sphere and Cylinder
- On Spirals

- The Sand Reckoner

The Roman's highest numeral was a myriad (10,000). Archimedes was not content to use that as the biggest number, so he decided to conduct an experiment using large numbers.

The question: How many grains of sand there are in the universe?

He made up a system to measure the sand. While solving this problem, Archimedes discovered something called powers. The answer to Archimedes' question was one with 62 zeros after it (1×10^{62}).

When numbers are multiplied by themselves, they are called powers.

Some powers of two are:

$$1 = 0 \text{ power} = 2^0$$

$$2 = 1^{\text{st}} \text{ power} = 2^1$$

$$2 \times 2 = 2^{\text{nd}} \text{ power (squared)} = 2^2$$

$$2 \times 2 \times 2 = 3^{\text{rd}} \text{ power (cubed)} = 2^3$$

$$2 \times 2 \times 2 \times 2 = 4^{\text{th}} \text{ power} = 2^4$$

There are short ways to write exponents. For example, a short way to write 81 is 3^4 . This is read as three to the fourth power.

- On Plane Equilibriums
- On Floating Bodies

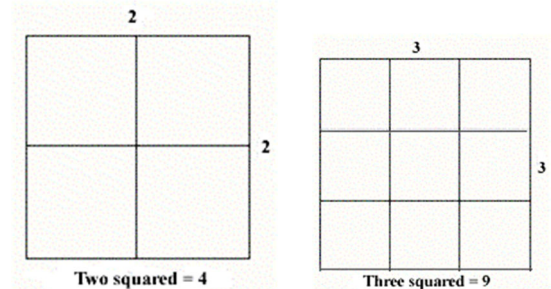

This problem was after Archimedes had solved the problem of King Hiero's gold crown. He experimented with liquids. He discovered *density* and *specific gravity*.

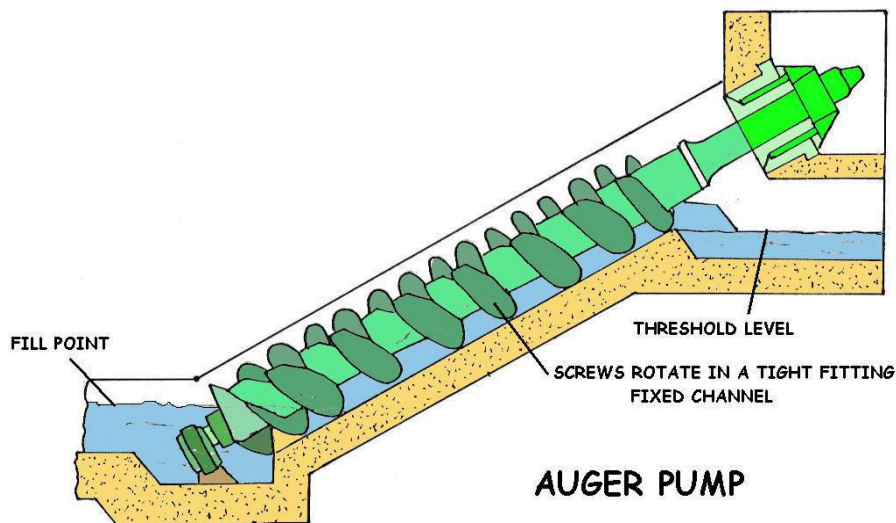

This pump is at least 2,000 years old.

The Archimedes Screw (also called an Archimedes Snail) was used for irrigation and powered by horses, people, mules, etc. This pump is even used today, although rarely! The helix revolves inside a tube (only the bottom of the tube is shown) and the water rises accordingly. Whether or not it was actually invented by Archimedes is certainly debatable, though his overall brilliance is not.

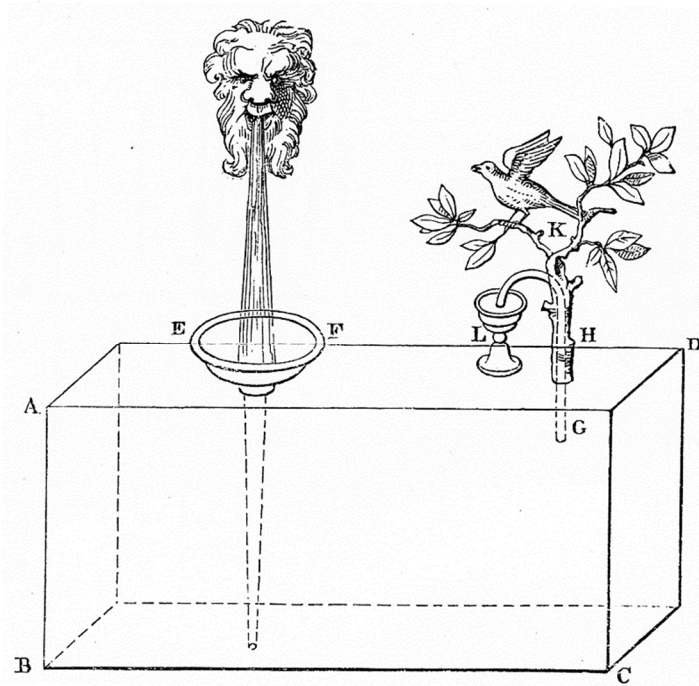

Inventions of Heron of Alexandria, above picture. The flow of water into a sealed container forces air out through a small bent tube. The air, bubbling into a cup of water, sounds like a bird singing. (The Pneumatics of Hero of Alexandria, page 29)

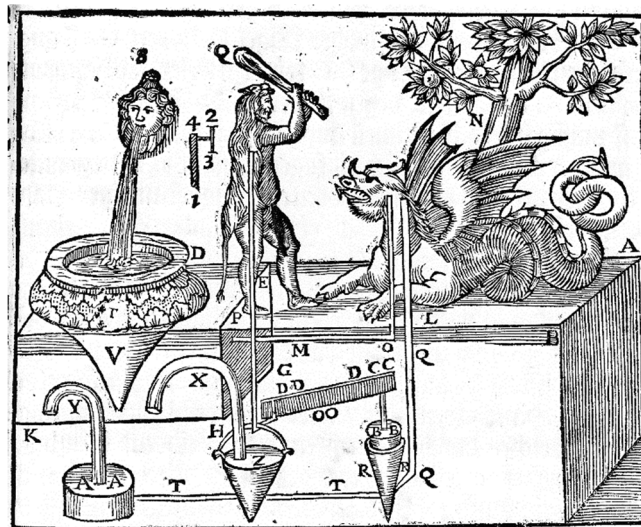

When the human figure is turned toward the dragon, a valve between the two sealed chambers under the figure closes. However if the human figure is rotated to the side, the valve connecting the two chambers opens, water flows from the top to the bottom chamber, and suction is created in the pipe leading from the upper chamber to the dragon's mouth. Because of this suction, the dragon appears to drink if a cup of water is held up to its mouth. (Buch von Luft-Und Wasser-Kunsten, page 3)

Heron of Alexandria

Heron, or Hiero, was a scientist and inventor in Alexandria. Heron wrote many books on mathematics, physics, geometry, and mechanics. The 'Pneumatica' describes mechanical devices operated by compressed air, water or steam, such as a fire engine, a water organ, and the aeolipile, which is the first steam-powered engine. His device consisted of a sphere mounted on a boiler by an axial shaft and having two canted nozzles to produce a rotary motion from the escaping steam. The later steam engines of the 18th century were partly based on this design. He was a Greek mathematician who was mainly interested in practical studies in mechanics and engineering. He dealt with a number of such problems in his work Dioptra. He is best known today for Proposition 1.8 of his Metrica, which is now known as Heron's formula.

The manuscript had been lost for centuries until a fragment was discovered in 1894, followed by a complete copy in 1896. The aeolipile (known as Hero's engine) was a rocket-like reaction engine and the first recorded steam engine.

It was created almost two millennia before the industrial revolution. Hero's steam engine was used to open temple doors, and as a toy, but the principles behind it were not well understood, and its full potential was not realized for well over a millennium.

The first vending machine was also one of his constructions, when a coin was introduced via a slot on the top of the machine; a set amount of Holy Water was dispensed. This was included in his list of inventions in his book, "Mechanics and Optics". When the coin was deposited, it fell upon a pan attached to a lever. The lever opened up a valve which let some water flow out. The pan continued to tilt with the weight of the coin until it fell off, at which point a counter-weight would snap the lever back up and turn off the valve. A windwheel operating an organ, marking probably the first instance of wind powering a machine in history.

Hero also invented many mechanisms for the Greek theater, including an entirely mechanical play almost ten minutes in length, powered by a binary-like system of ropes, knots, and simple machines operated by a rotating cylindrical cogwheel. The sound of thunder was produced by the mechanically-timed dropping of metal balls onto a hidden drum.

In Optics, Hero formulated the Principle of the Shortest Path of Light: If a ray of light propagates from point A to point B within the same medium, the path-length followed is the shortest possible. It was nearly 1000 years later that Ibn al-Haytham expanded the principle to both reflection and refraction, and the principle was not stated in this form until Pierre de Fermat did so in 1662; the most modern form is that the path is at an extremum.

A standalone fountain that operates under self-contained hydrostatic energy. (Heron's fountain)
Mathematics

Heron described a method of iteratively computing the square root. It is also called the Babylonian method, because the Babylonians also probably knew of it before Heron wrote it down.

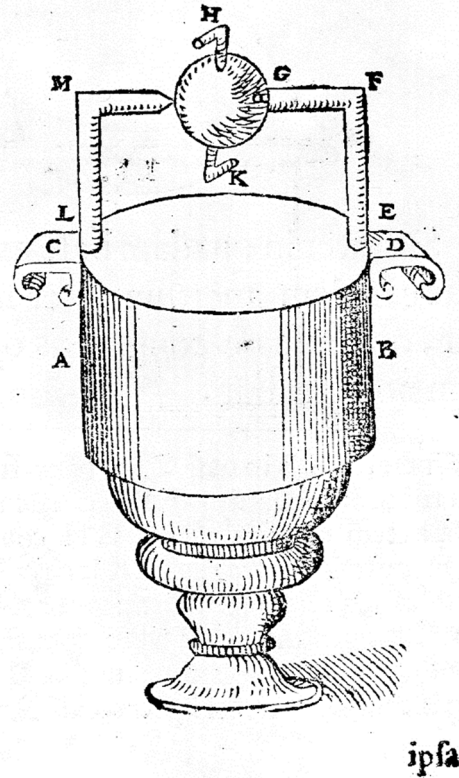
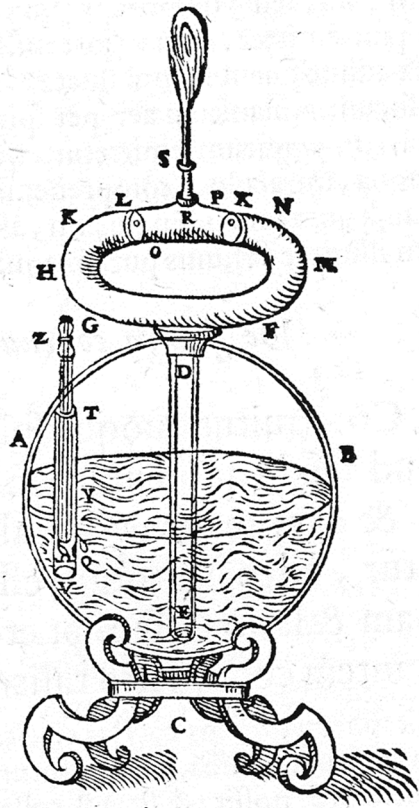

On the left hand side, a water jet produced by mechanically compressed air. (Pneumatics, page 23, OR *Spiritualium Liber*, page 19.)

On the right hand side, steam, produced in a heated pot, is fed into a ball that is held on 2 pivots, which spins when the steam exits via bent tubes. This device is one of the earliest suggestions of the steam engine. (*Spiritualium Liber*, page 52)

Hero in the History of Hydraulics Collection:

- * *Spiritualium Liber*, Latin translation of Hero's *Pneumatics*, published 1575, Urbino, Italy. (Call number QC 142 H54)
- * *De Gli Automati, Overo Machine Se Moventi* (Italian translation of Hero's *Mechanics*, published 1601 in Venice, Italy) (Call number: TJ215 H4)
- * *Buch von Lufft-Und Wasser-Kunsten* (German translation of Hero's *Pneumatics*, published 1688, Frankfurt) (Call number: Q147 H4)
- * *The Pneumatics of Hero of Alexandria* (English translation, published London, 1851) (Call number: QC 142 H52)



DANIEL BERNOULLI (1700-1782)

Daniel Bernoulli was born in Groningen, in the Netherlands, into a family of distinguished mathematicians. The Bernoulli family came originally from Antwerp, at that time in the Spanish Netherlands, but emigrated to escape the Spanish persecution of the Huguenots. After a brief period in Frankfurt the family moved to Basel, in Switzerland.

Daniel was the son of Johann Bernoulli (one of the "early developers" of calculus), nephew of Jakob Bernoulli (who "was the first to discover the theory of probability"), and older brother of Johann II. Daniel Bernoulli was described by W. W. Rouse Ball as "by far the ablest of the younger Bernoullis". He is said to have had a bad relationship with his father, Johann. Upon both of them entering and tying for first place in a scientific contest at the University of Paris, Johann, unable to bear the "shame" of being compared as Daniel's equal, banned Daniel from his house.

Johann Bernoulli also plagiarized some key ideas from Daniel's book *Hydrodynamica* in his own book *Hydraulica* which he backdated to before *Hydrodynamica*. Despite Daniel's attempts at reconciliation, his father carried the grudge until his death.

When Daniel was seven, his younger brother Johann II Bernoulli was born. Around schooling age, his father, Johann Bernoulli, encouraged him to study business, there being poor rewards awaiting a mathematician. However, Daniel refused, because he wanted to study mathematics. He later gave in to his father's wish and studied business.



BLAISE PASCAL (1623-1662)

Blaise Pascal (19 June 1623 – 19 August 1662) was a French mathematician, physicist, inventor, writer and Christian philosopher. He was a child prodigy who was educated by his father, a tax collector in Rouen. Pascal's earliest work was in the natural and applied sciences where he made important contributions to the study of fluids, and clarified the concepts of pressure and vacuum by generalizing the work of Evangelista Torricelli. Pascal also wrote in defense of the scientific method.

In 1642, while still a teenager, he started some pioneering work on calculating machines. After three years of effort and fifty prototypes, he invented the mechanical calculator. He built 20 of these machines (called Pascal's calculator and later pascaline) in the following ten years. Pascal was an important mathematician, helping create two major new areas of research: he wrote a significant treatise on the subject of projective geometry at the age of 16, and later corresponded with Pierre de Fermat on probability theory, strongly influencing the development of modern economics and social science. Following Galileo and Torricelli, in 1646 he refuted Aristotle's followers who insisted that nature abhors a vacuum. Pascal's results caused many disputes before being accepted.

In 1646, he and his sister Jacqueline identified with the religious movement within Catholicism known by its detractors as Jansenism. His father died in 1651. Following a mystical experience in late 1654, he had his "second conversion", abandoned his scientific work, and devoted himself to philosophy and theology. His two most famous works date from this period: the *Lettres provinciales* and the *Pensées*, the former set in the conflict between Jansenists and Jesuits. In this year, he also wrote an important treatise on the arithmetical triangle. Between 1658 and 1659 he wrote on the cycloid and its use in calculating the volume of solids. Pascal had poor health especially after his 18th year and his death came just two months after his 39th birthday.

Development of Hydraulics

Although the modern development of hydraulics is comparatively recent, the ancients were familiar with many hydraulic principles and their applications. The Egyptians and the ancient people of Persia, India, and China conveyed water along channels for irrigation and domestic purposes, using dams and sluice gates to control the flow. The ancient Cretans had an elaborate plumbing system. Archimedes studied the laws of floating and submerged bodies. The Romans constructed aqueducts to carry water to their cities.

After the breakup of the ancient world, there were few new developments for many centuries. Then, over a comparatively short period, beginning near the end of the seventeenth century, Italian physicist, Evangelista Torricelle, French physicist, Edme Mariotte, and later, Daniel Bernoulli conducted experiments to study the elements of force in the discharge of water through small openings in the sides of tanks and through short pipes. During the same period, Blaise Pascal, a French scientist, discovered the fundamental law for the science of hydraulics. Pascal's law states that increase in pressure on the surface of a confined fluid is transmitted undiminished throughout the confining vessel or system.

For Pascal's law to be made effective for practical applications, it was necessary to have a piston that "fit exactly." It was not until the latter part of the eighteenth century that methods were found to make these snugly fitted parts required in hydraulic systems.

This was accomplished by the invention of machines that were used to cut and shape the necessary closely fitted parts and, particularly, by the development of gaskets and packings. Since that time, components such as valves, pumps, actuating cylinders, and motors have been developed and refined to make hydraulics one of the leading methods of transmitting power.

Liquids are almost incompressible. For example, if a pressure of 100 pounds per square inch (**psi**) is applied to a given volume of water that is at atmospheric pressure, the volume will decrease by only 0.03 percent. It would take a force of approximately 32 tons to reduce its volume by 10 percent; however, when this force is removed, the water immediately returns to its original volume. Other liquids behave in about the same manner as water.

Another characteristic of a liquid is the tendency to keep its free surface level. If the surface is not level, liquids will flow in the direction which will tend to *make* the surface level.

Evangelista Torricelli

Evangelista Torricelli (1608-1647), Galileo's student and secretary, and a member of the Florentine Academy of Experiments, invented the mercury barometer in 1643, and brought the weight of the atmosphere to light. The mercury column was held up by the pressure of the atmosphere, not by horror vacui as Aristotle had supposed. Torricelli's early death was a blow to science, but his ideas were furthered by Blaise Pascal (1623-1662).

Pascal had a barometer carried up the 1465 m high Puy de Dôme, an extinct volcano in the Auvergne just west of his home of Clermont-Ferrand in 1648 by Périer, his brother-in-law. Pascal's experimentum crucis is one of the triumphs of early modern science. The Puy de Dôme is not the highest peak in the Massif Central--the Puy de Sancy, at 1866 m is, but it was the closest. Clermont is now the centre of the French pneumatics industry.

Burgomeister of Magdeburg

The remarkable Otto von Guericke (1602-1686), Burgomeister of Magdeburg, Saxony, took up the cause, making the first vacuum pump, which he used in vivid demonstrations of the pressure of the atmosphere to the Imperial Diet at Regensburg in 1654. Famously, he evacuated a sphere consisting of two well-fitting hemispheres about a foot in diameter, and showed that 16 horses, 8 on each side, could not pull them apart. An original vacuum pump and hemispheres from 1663 are shown at the right (photo edited from the Deutsches Museum; see right). He also showed that air had weight, and how much force it required to separate evacuated hemispheres. Then, in England, Robert Hooke (1635-1703) made a vacuum pump for Robert Boyle (1627-1691). Christian Huygens (1629-1695) became interested in a visit to London in 1661 and had a vacuum pump built for him. By this time, Torricelli's doctrine had triumphed over the Church's support for horror vacui. This was one of the first victories for rational physics over the illusions of experience, and is well worth consideration.



Pascal demonstrated that the siphon worked by atmospheric pressure, not by horror vacui. The two beakers of mercury are connected by a three-way tube as shown, with the upper branch open to the atmosphere. As the large container is filled with water, pressure on the free surfaces of the mercury in the beakers pushes mercury into the tubes. When the state shown is reached, the beakers are connected by a mercury column, and the siphon starts, emptying the upper beaker and filling the lower. The mercury has been open to the atmosphere all this time, so if there were any horror vacui, it could have flowed in at will to soothe itself.

Torr

The mm of mercury is sometimes called a torr after Torricelli, and Pascal also has been honored by a unit of pressure, a newton per square meter or 10 dyne/cm^2 . A cubic centimeter of air weighs 1.293 mg under standard conditions, and a cubic meter 1.293 kg, so air is by no means even approximately weightless, though it seems so.

The weight of a sphere of air as small as 10 cm in diameter is 0.68 g, easily measurable with a chemical balance. The pressure of the atmosphere is also considerable, like being 34 ft under water, but we do not notice it. A bar is 10^6 dyne/cm^2 , very close to a standard atmosphere, which is 1.01325 bar. In meteorology, the millibar, mb, is used. $1 \text{ mb} = 1.333 \text{ mmHg} = 100 \text{ Pa} = 1000 \text{ dyne/cm}^2$.

A kilogram-force per square centimeter is $981,000 \text{ dyne/cm}^2$, also close to one atmosphere. In Europe, it has been considered approximately 1 atm, as in tire pressures and other engineering applications. As we have seen, in English units the atmosphere is about 14.7 psi, and this figure can be used to find other approximate equivalents. For example, $1 \text{ psi} = 51.7 \text{ mmHg}$. In Britain, tons per square inch has been used for large pressures.

The ton in this case is 2240 lb, not the American short ton. $1 \text{ tsi} = 2240 \text{ psi}$, $1 \text{ tsf} = 15.5 \text{ psi}$ (about an atmosphere!). The fluid in question here is air, which is by no means incompressible. As we rise in the atmosphere and the pressure decreases, the air also expands.

To see what happens in this case, we can make use of the ideal gas equation of state, $p = \rho RT/M$, and assume that the temperature T is constant. Then the change of pressure in a change of altitude dh is $dp = -\rho g dh = -(\rho M/RT)gdh$, or $dp/p = -(Mg/RT)dh$.

This is a little harder to integrate than before, but the result is $\ln p = -Mgh/RT + C$, or $\ln(p/p_0) = -Mgh/RT$, or finally $p = p_0 \exp(-Mgh/RT)$. In an isothermal atmosphere, the pressure decreases exponentially. The quantity $H = RT/Mg$ is called the "height of the homogeneous atmosphere" or the scale height, and is about 8 km at $T = 273K$.

This quantity gives the rough scale of the decrease of pressure with height. Of course, the real atmosphere is by no means isothermal close to the ground, but cools with height nearly linearly at about $6.5^\circ\text{C}/\text{km}$ up to an altitude of about 11 km at middle latitudes, called the tropopause. Above this is a region of nearly constant temperature, the stratosphere, and then at some higher level the atmosphere warms again to near its value at the surface. Of course, there are variations from the average values. When the temperature profile with height is known, we can find the pressure by numerical integration quite easily.

Meteorology

The atmospheric pressure is of great importance in meteorology, since it determines the winds, which generally move at right angles to the direction of the most rapid change of pressure, that is, along the isobars, which are contours of constant pressure. Certain typical weather patterns are associated with relatively high and relatively low pressures, and how they vary with time. The barometric pressure may be given in popular weather forecasts, though few people know what to do with it.

If you live at a high altitude, your local weather reporter may report the pressure to be, say, 29.2 inches, but if you have a real barometer, you may well find that it is closer to 25 inches. At an elevation of 1500 m (near Denver, or the top of the Puy de Dôme), the atmospheric pressure is about 635 mm, and water boils at 95°C .

In fact, altitude is quite a problem in meteorology, since pressures must be measured at a common level to be meaningful. The barometric pressures quoted in the news are reduced to sea level by standard formulas that amount to assuming that there is a column of air from your feet to sea level with a certain temperature distribution, and adding the weight of this column to the actual barometric pressure. This is only an arbitrary 'fix' and leads to some strange conclusions, such as the permanent winter highs above high plateaus that are really imaginary.

Pascal's Law

The foundation of modern hydraulics was established when Pascal discovered that pressure in a fluid acts equally in all directions. This pressure acts at right angles to the containing surfaces. If some type of pressure gauge, with an exposed face, is placed beneath the surface of a liquid at a specific depth and pointed in different directions, the pressure will read the same. Thus, we can say that pressure in a liquid is independent of direction.

Pressure due to the weight of a liquid, at any level, depends on the depth of the fluid from the surface. If the exposed face of the pressure gauges are moved closer to the surface of the liquid, the indicated pressure will be less. When the depth is doubled, the indicated pressure is doubled. Thus the pressure in a liquid is directly proportional to the depth.

Consider a container with vertical sides that is 1 foot long and 1 foot wide. Let it be filled with water 1 foot deep, providing 1 cubic foot of water. 1 cubic foot of water weighs 62.4 pounds. Using this information and equation, $P = F/A$, we can calculate the pressure on the bottom of the container.

Since there are 144 square inches in 1 square foot, this can be stated as follows: the weight of a column of water 1 foot high, having a cross-sectional area of 1 square inch, is 0.433 pound. If the depth of the column is tripled, the weight of the column will be 3×0.433 , or 1.299 pounds, and the pressure at the bottom will be 1.299 lb/in² (psi), since pressure equals the force divided by the area.

Thus, the pressure at any depth in a liquid is equal to the weight of the column of liquid at that depth divided by the cross-sectional area of the column at that depth. The volume of a liquid that produces the pressure is referred to as the fluid head of the liquid. The pressure of a liquid due to its fluid head is also dependent on the density of the liquid.

Gravity

Gravity is one of the four forces of nature. The strength of the gravitational force between two objects depends on their masses. The more massive the objects are, the stronger the gravitational attraction. When you pour water out of a container, the earth's gravity pulls the water towards the ground. The same thing happens when you put two buckets of water, with a tube between them, at two different heights. You must work to start the flow of water from one bucket to the other, but then gravity takes over and the process will continue on its own.

Gravity, applied forces, and atmospheric pressure are static factors that apply equally to fluids at rest or in motion, while inertia and friction are dynamic factors that apply only to fluids in motion. The mathematical sum of gravity, applied force, and atmospheric pressure is the static pressure obtained at any one point in a fluid at any given time.

Static Pressure

Static pressure exists in addition to any dynamic factors that may also be present at the same time. Pascal's law states that a pressure set up in a fluid acts equally in all directions and at right angles to the containing surfaces. This covers the situation only for fluids at rest or practically at rest. It is true only for the factors making up static head.

Obviously, when velocity becomes a factor it must have a direction, and as previously explained, the force related to the velocity must also have a direction, so that Pascal's law alone does not apply to the dynamic factors of fluid power.

The dynamic factors of inertia and friction are related to the static factors. Velocity head and friction head are obtained at the expense of static head. However, a portion of the velocity head can always be reconverted to static head. Force, which can be produced by pressure or head when dealing with fluids, is necessary to start a body moving if it is at rest, and is present in some form when the motion of the body is arrested; therefore, whenever a fluid is given velocity, some part of its original static head is used to impart this velocity, which then exists as velocity head.

Volume and Velocity of Flow

The volume of a liquid passing a point in a given time is known as its **volume of flow** or flow rate. The volume of flow is usually expressed in gallons per minute (gpm) and is associated with relative pressures of the liquid, such as 5 gpm at 40 psi.

The **velocity of flow** or velocity of the fluid is defined as the average speed at which the fluid moves past a given point. It is usually expressed in feet per second (fps) or feet per minute (fpm). Velocity of flow is an important consideration in sizing the hydraulic lines.

Volume and velocity of flow are often considered together. With other conditions unaltered—that is, with volume of input unchanged—the velocity of flow increases as the cross section or size of the pipe decreases, and the velocity of flow decreases as the cross section increases. For example, the velocity of flow is slow at wide parts of a stream and rapid at narrow parts, yet the volume of water passing each part of the stream is the same.

Bernoulli's Principle

Bernoulli's principle thus says that a rise (fall) in pressure in a flowing fluid must always be accompanied by a decrease (increase) in the speed, and conversely, if an increase (decrease) in the speed of the fluid results in a decrease (increase) in the pressure.

This is at the heart of a number of everyday phenomena. As a very trivial example, Bernoulli's principle is responsible for the fact that a shower curtain gets "**sucked inwards**" when the water is first turned on. What happens is that the increased water/air velocity inside the curtain (relative to the still air on the other side) causes a pressure drop.

The pressure difference between the outside and inside causes a net force on the shower curtain which sucks it inward. A more useful example is provided by the functioning of a perfume bottle: squeezing the bulb over the fluid creates a low pressure area due to the higher speed of the air, which subsequently draws the fluid up. This is illustrated in the following figure.

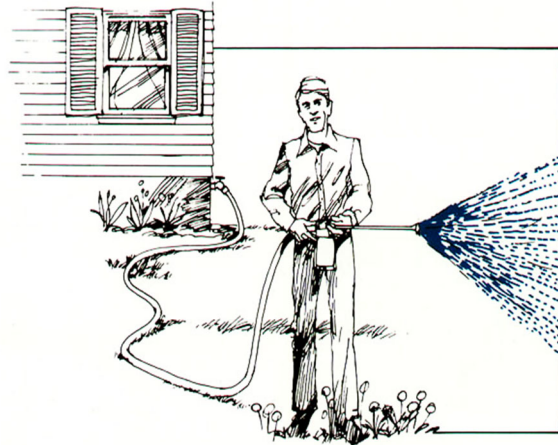

Action of a spray atomizer→

Bernoulli's principle also tells us why windows tend to explode, rather than implode in hurricanes: the very high speed of the air just outside the window causes the pressure just outside to be much less than the pressure inside, where the air is still. The difference in force pushes the windows outward, and hence they explode. If you know that a hurricane is coming it is therefore better to open as many windows as possible, to equalize the pressure inside and out.

Another example of Bernoulli's principle at work is in the lift of aircraft wings and the motion of "**curve balls**" in baseball.

In both cases the design is such as to create a speed differential of the flowing air past the object on the top and the bottom - for aircraft wings this comes from the movement of the flaps, and for the baseball it is the presence of ridges.

Such a speed differential leads to a pressure difference between the top and bottom of the object, resulting in a net force being exerted, either upwards or downwards.



Bernoulli's Equation

Glenn
Research
Center

Restrictions :

- Inviscid
- Steady
- Incompressible (low velocity)
- No heat addition.
- Negligible change in height.

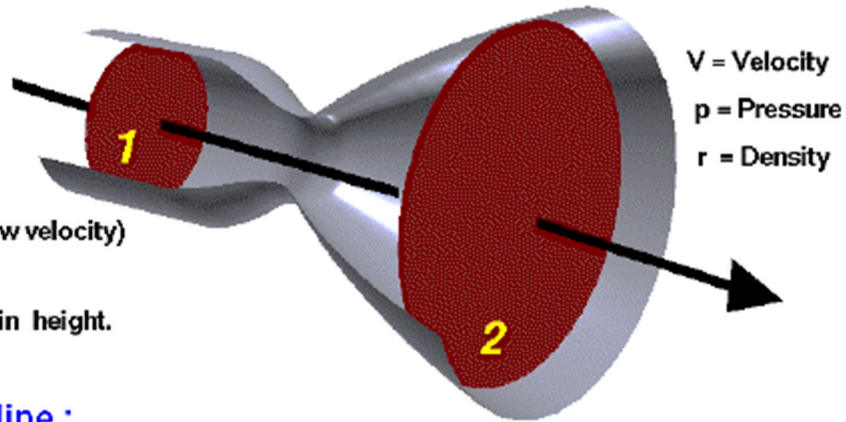

Along a streamline :

static pressure + dynamic pressure = total pressure

$$p_s + \frac{rV^2}{2} = p_t$$

$$\left(p_s + \frac{rV^2}{2} \right)_1 = \left(p_s + \frac{rV^2}{2} \right)_2$$

The Hydraulic Lever

A cylinder and piston is a chamber of variable volume, a mechanism for transforming pressure to force.

If A is the area of the cylinder, and p the pressure of the fluid in it, then $F = pA$ is the force on the piston. If the piston moves outwards a distance dx , then the change in volume is $dV = A dx$.

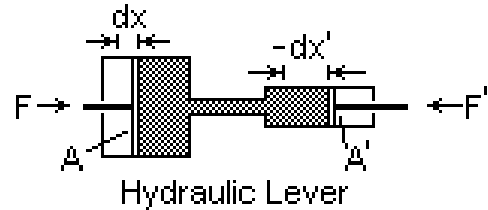

The work done by the fluid in this displacement is $dW = F dx = pA dx = p dV$. If the movement is slow enough that inertia and viscosity forces are negligible, then hydrostatics will still be valid.

A process for which this is true is called quasi-static. Now consider two cylinders, possibly of different areas A and A' , connected with each other and filled with fluid. For simplicity, suppose that there are no gravitational forces.

Then the pressure is the same, p , in both cylinders. If the fluid is incompressible, then $dV + dV' = 0$, so that $dW = p dV + p dV' = F dx + F' dx' = 0$. This says the work done on one piston is equal to the work done by the other piston: the conservation of energy. The ratio of the forces on the pistons is $F' / F = A' / A$, the same as the ratio of the areas, and the ratios of the displacements $dx' / dx = F / F' = A / A'$ is in the inverse ratio of the areas. This mechanism is the hydrostatic analogue of the lever, and is the basis of hydraulic activation.

Bramah Hydraulic Press

The most famous application of this principle is the Bramah hydraulic press, invented by Joseph Bramah (1748-1814), who also invented many other useful machines, including a lock and a toilet. Now, it was not very remarkable to see the possibility of a hydraulic press; what was remarkable was to find a way to seal the large cylinder properly.

This was the crucial problem that Bramah solved by his leather seal that was held against the cylinder and the piston by the hydraulic pressure itself.

In the presence of gravity, $p' = p + \rho gh$, where h is the difference in elevation of the two cylinders. Now, $p' dV' = -dV (p + \rho gh) = -p dV - (\rho dV)gh$, or the net work done in the process is $p' dV' + p dV = -dM gh$, where dM is the mass of fluid displaced from the lower cylinder to the upper cylinder. Again, energy is conserved if we take into account the potential energy of the fluid. Pumps are seen to fall within the province of hydrostatics if their operation is quasi-static, which means that dynamic or inertia forces are negligible.

Pumps

Pumps are used to move or raise fluids. They are not only very useful, but are excellent examples of hydrostatics. Pumps are of two general types, hydrostatic or positive displacement pumps, and pumps depending on dynamic forces, such as centrifugal pumps. Here we will only consider positive displacement pumps, which can be understood purely by hydrostatic considerations. They have a piston (or equivalent) moving in a closely-fitting cylinder and forces are exerted on the fluid by motion of the piston.

We have already seen an important example of this in the hydraulic lever or hydraulic press, which we have called quasi-static. The simplest pump is the syringe, filled by withdrawing the piston and emptied by pressing it back in, as its port is immersed in the fluid or removed from it.

More complicated pumps have valves allowing them to work repetitively. These are usually check valves that open to allow passage in one direction, and close automatically to prevent reverse flow. There are many kinds of valves, and they are usually the most trouble-prone and complicated part of a pump. The force pump has two check valves in the cylinder, one for supply and the other for delivery. The supply valve opens when the cylinder volume increases, the delivery valve when the cylinder volume decreases. The lift pump has a supply valve, and a valve in the piston that allows the liquid to pass around it when the volume of the cylinder is reduced. The delivery in this case is from the upper part of the cylinder which the piston does not enter. Diaphragm pumps are force pumps in which the oscillating diaphragm takes the place of the piston. The diaphragm may be moved mechanically, or by the pressure of the fluid on one side of the diaphragm.

Some positive displacement pumps are shown below. The force and lift pumps are typically used for water. The force pump has two valves in the cylinder, while the lift pump has a one valve in the cylinder and one in the piston. The maximum lift, or "suction," is determined by the atmospheric pressure, and either cylinder must be within this height of the free surface. The force pump, however, can give an arbitrarily large pressure to the discharged fluid, as in the case of a diesel engine injector.

A nozzle can be used to convert the pressure to velocity, to produce a jet, as for firefighting. Fire fighting force pumps usually have two cylinders feeding one receiver alternately. The air space in the receiver helps to make the water pressure uniform.

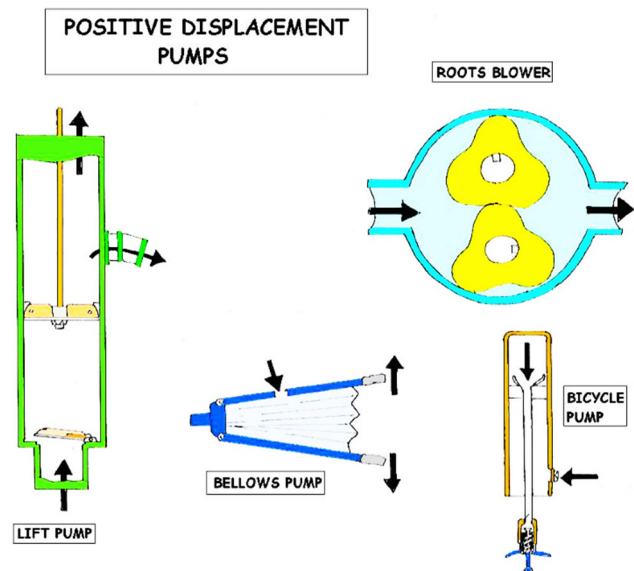

The three pumps on the right are typically used for air, but would be equally applicable to liquids. The Roots blower has no valves, their place taken by the sliding contact between the rotors and the housing. The Roots blower can either exhaust a receiver or provide air under moderate pressure, in large volumes. The bellows is a very old device, requiring no accurate machining. The single valve is in one or both sides of the expandable chamber. Another valve can be placed at the nozzle if required. The valve can be a piece of soft leather held close to holes in the chamber. The bicycle pump uses the valve on the valve stem of the tire or inner tube to hold pressure in the tire. The piston, which is attached to the discharge tube, has a flexible seal that seals when the cylinder is moved to compress the air, but allows air to pass when the movement is reversed.

Diaphragm and vane pumps are not shown, but they act the same way by varying the volume of a chamber, and directing the flow with check valves. Pumps were applied to the dewatering of mines, a very necessary process as mines became deeper. Newcomen's atmospheric engine was invented to supply the power for pumping.

Dudley Castle Engine

The first engine may have been erected in Cornwall in 1710, but the Dudley Castle engine of 1712 is much better known and thoroughly documented. The first pumps used in Cornwall were called bucket pumps, which we recognize as lift pumps, with the pistons somewhat miscalled buckets. They pumped on the up-stroke, when a clack in the bottom of the pipe opened and allowed water to enter beneath the piston. At the same time, the piston lifted the column of water above it, which could be of any length. The piston could only "suck" water 33 ft, or 28 ft more practically, of course, but this occurred at the bottom of the shaft, so this was only a limit on the piston stroke. On the down stroke, a clack in the bucket opened, allowing it to sink through the water to the bottom, where it would be ready to make another lift.

More satisfactory were the plunger pumps, also placed at the bottom of the shaft. A plunger displaced volume in a chamber, forcing the water in it through a check valve up the shaft, when it descended. When it rose, water entered the pump chamber through a clack, as in the bucket pump. Only the top of the plunger had to be packed; it was not necessary that it fit the cylinder accurately. In this case, the engine at the surface lifted the heavy pump rods on the up-stroke. When the atmospheric engine piston returned, the heavy timber pump rods did the actual pumping, borne down by their weight. A special application for pumps is to produce a vacuum by exhausting a container, called the receiver.

Hawksbee's Dual Cylinder Pump

Hawksbee's dual cylinder pump, designed in the 18th century, is the final form of the air pump invented by Guericke by 1654. A good pump could probably reach about 5-10 mmHg, the limit set by the valves. The cooperation of the cylinders made the pump much easier to work when the pressure was low. In the diagram, piston A is descending, helped by the partial vacuum remaining below it, while piston B is rising, filling with the low-pressure air from the receiver.

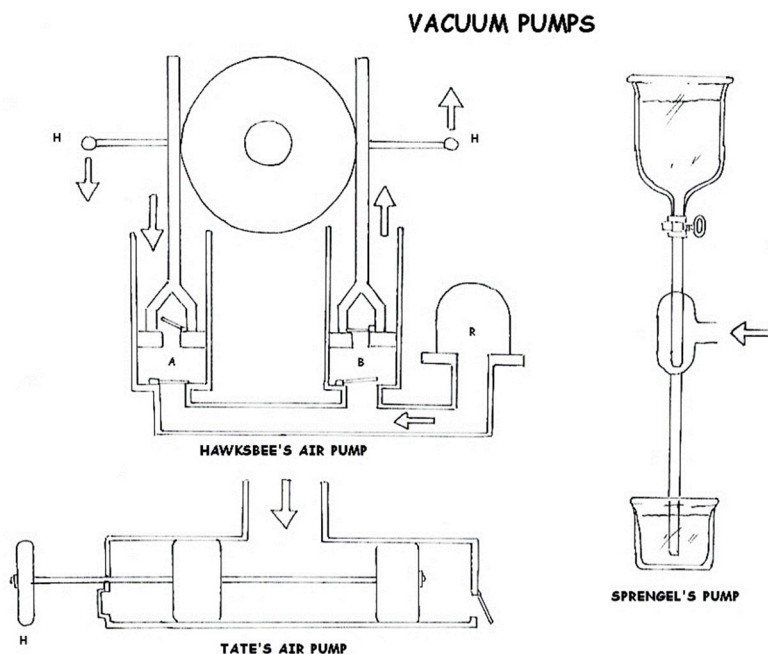

Bell-jar Receiver

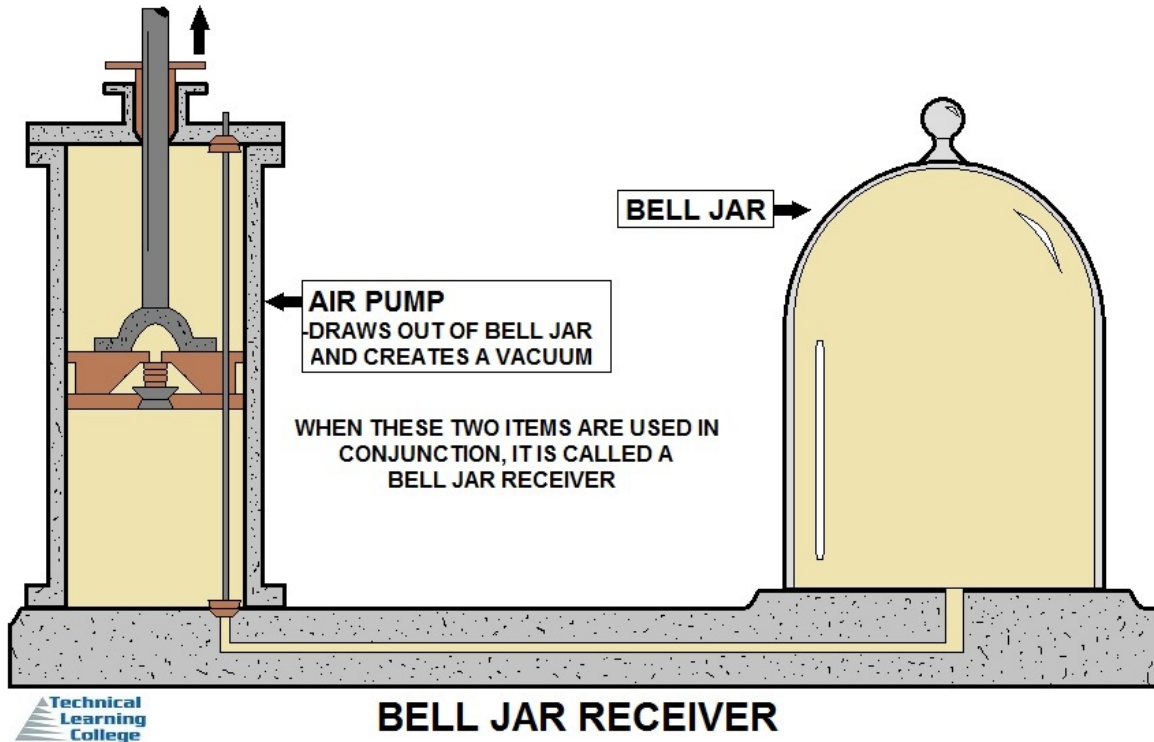

The bell-jar receiver, invented by Huygens, is shown; previously, a cumbersome globe was the usual receiver. Tate's air pump is a 19th century pump that would be used for simple vacuum demonstrations and for utility purposes in the lab. It has no valves on the low-pressure side, just exhaust valves V, V', so it could probably reach about 1 mmHg. It is operated by pushing and pulling the handle H. At the present day, motor-driven rotary-seal pumps sealed by running in oil are used for the same purpose. At the right is Sprengel's pump, with the valves replaced by drops of mercury. Small amounts of gas are trapped at the top of the fall tube as the mercury drops, and moves slowly down the fall tube as mercury is steadily added, coming out at the bottom carrying the air with it. The length of the fall tube must be greater than the barometric height, of course.

Theoretically, a vacuum of about $1 \mu\text{m}$ can be obtained with a Sprengel pump, but it is very slow and can only evacuate small volumes. Later, Langmuir's mercury diffusion pump, which was much faster, replaced Sprengel pumps, and led to oil diffusion pumps that can reach very high vacua. The column of water or hydrostatic engine is the inverse of the force pump, used to turn a large head (pressure) of water into rotary motion. It looks like a steam engine, with valves operated by valve gear, but of course is not a heat engine and can be of high efficiency.

However, it is not of as high efficiency as a turbine, and is much more complicated, but has the advantage that it can be operated at variable speeds, as for lifting. A few very impressive column of water engines were made in the 19th century, but they were never popular and remained rare. Richard Trevithick, famous for high pressure steam engines,

also built hydrostatic engines in Cornwall. The photograph at the right shows a column-of-water engine built by Georg von Reichenbach, and placed in service in 1917. This engine was exhibited in the Deutsches Museum in München as late as 1977.

It was used to pump brine for the Bavarian state salt industry. A search of the museum website did not reveal any evidence of it, but a good drawing of another brine pump with four cylinders and driven by a water wheel, also built by von Reichenbach, was found.

Solehebemaschine

This machine, a Solehebemaschine ("brine-lifting machine"), entered service in 1821. It had two pressure-operated poppet valves for each cylinder. These engines are brass to resist corrosion by the salt water. Water pressure engines must be designed taking into account the incompressibility of water, so both valves must not close at the same time, and abrupt changes of rate of flow must not be made. Air chambers can be used to eliminate shocks. Georg von Reichenbach (1771-1826) is much better known as an optical designer than as a mechanical engineer. He was associated with Joseph Fraunhofer, and they died within days of each other in 1826. He was of an aristocratic family, and was Salinenrat, or manager, of the state salt works, in southeastern Bavaria, which was centered on the town of Reichenhall, now Bad Reichenhall, near Salzburg.



The name derives from "rich in salt." This famous salt region had salt springs flowing nearly saturated brine, at 24% to 26% (saturated is 27%) salt, that from ancient times had been evaporated over wood fires. A brine pipeline to Traunstein was constructed in 1617-1619, since wood fuel for evaporating the brine was exhausted in Reichenhall. The pipeline was further extended to Rosenheim, where there was turf as well as wood, in 1818-10. Von Reichenbach is said to have built this pipeline, for which he designed a water-wheel-driven, four-barrel pump. Maximilian I, King of Bavaria, commissioned von Reichenbach to bring brine from Berchtesgaden, elevation 530 m, to Reichenhall, elevation 470 m, over a summit 943 m high.

The pump shown in the photograph pumped brine over this line, entering service in 1816. Fresh water was also allowed to flow down to the salt beds, and the brine was then pumped to the surface. This was a much easier way to mine salt than underground mining. The salt industry of Bad Reichenhall still operates, but it is now Japanese-owned.

Forces on Submerged Surfaces

Suppose we want to know the force exerted on a vertical surface of any shape with water on one side, assuming gravity to act, and the pressure on the surface of the water zero. We have already solved this problem by a geometrical argument, but now we apply calculus, which is easier but not as illuminating.

The force on a small area dA a distance x below the surface of the water is $dF = p \, dA = \rho g x \, dA$, and the moment of this force about a point on the surface is $dM = p x \, dA = \rho g x^2 \, dA$.

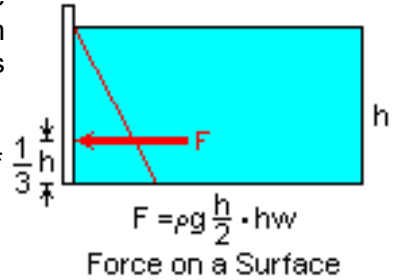

By integration, we can find the total force F , and the depth at which it acts, $c = M / F$. If the surface is not symmetrical, the position of the total force in the transverse direction can be obtained from the integral of $dM' = \rho g x y \, dA$, the moment about some vertical line in the plane of the surface. If there happens to be a pressure on the free surface of the water, then the forces due to this pressure can be evaluated separately and added to this result. We must add a force equal to the area of the surface times the additional pressure, and a moment equal to the product of this force and the distance to the centroid of the surface.

The simplest case is a rectangular gate of width w , and height h , whose top is a distance H below the surface of the water.

In this case, the integrations are very easy, and $F = \rho g w [(h + H)^2 - h^2] / 2 = \rho g H (H + 2h) / 2 = \rho g (h + H/2) H w$.

The total force on the gate is equal to its area times the pressure at its centre. $M = \rho g w [(h + H)^3 - h^3] / 3 = \rho g (H^2/3 + Hh + h^2) H w$, so that $c = (H^2/3 + Hh + h^2) / (h + H/2)$.

In the simple case of $h = 0$, $c = 2H/3$, or two-thirds of the way from the top to the bottom of the gate. If we take the atmospheric pressure to act not only on the surface of the water, but also the dry side of the gate, there is no change to this result. This is the reason atmospheric pressure often seems to have been neglected in solving sub h problems. Consider a curious rectangular tank, with one side vertical but the opposite side inclined inwards or outwards. The horizontal forces exerted by the water on the two sides must be equal and opposite, or the tank would scoot off. If the side is inclined outward, then there must be a downward vertical force equal to the weight of the water above it, and passing through the centroid of this water. If the side is inclined inward, there must be an upward vertical force equal to the weight of the 'missing' water above it. In both cases, the result is demanded by ordinary statics.

Hydrostatic Paradox

What we have here has been called the 'hydrostatic paradox.' It was conceived by the celebrated Flemish engineer Simon Stevin (1548-1620) of Brugge, the first modern scientist to investigate the statics of fluids and solids. Consider three tanks with bottoms of equal sizes and equal heights, filled with water. The pressures at the bottoms are equal, so the vertical force on the bottom of each tank is the same. But suppose that one tank has vertical sides, one has sides inclined inward, and third sides inclined outward.

Hydrostatic Paradox

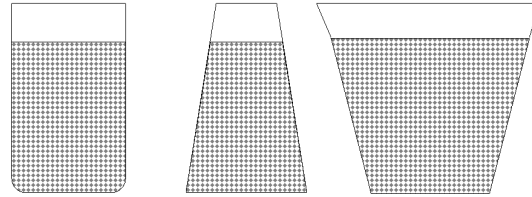

The tanks do not contain the same weight of water, yet the forces on their bottoms are equal! I am sure that you can spot the resolution of this paradox. Sometimes the forces are required on curved surfaces. The vertical and horizontal components can be found by considering the equilibrium of volumes with a plane surface equal to the projected area of the curved surface in that direction.

The general result is usually a force plus a couple, since the horizontal and vertical forces are not necessarily in the same plane. Simple surfaces, such as cylinders, spheres and cones, may often be easy to solve. In general, however, it is necessary to sum the forces and moments numerically on each element of area, and only in simple cases can this be done analytically.

If a volume of fluid is accelerated uniformly, the acceleration can be added to the acceleration of gravity. A free surface now becomes perpendicular to the total acceleration, and the pressure is proportional to the distance from this surface. The same can be done for a rotating fluid, where the centrifugal acceleration is the important quantity. The earth's atmosphere is an example. When air moves relative to the rotating system, the Coriolis force must also be taken into account. However, these are dynamic effects and are not strictly a part of hydrostatics.

Buoyancy

Archimedes, so the legend runs, was asked to determine if the goldsmith who made a golden crown for Hieron, Tyrant of Syracuse, had substituted cheaper metals for gold. The story is told by Vitruvius. A substitution could not be detected by simply weighing the crown, since it was craftily made to the same weight as the gold supplied for its construction. Archimedes realized that finding the density of the crown, that is, the weight per unit volume, would give the answer.

The weight was known, of course, and Archimedes cunningly measured its volume by the amount of water that ran off when it was immersed in a vessel filled to the brim. By comparing the results for the crown, and for pure gold, it was found that the crown displaced more water than an equal weight of gold, and had, therefore, been adulterated.

This story, typical of the charming way science was made more interesting in classical times, may or may not actually have taken place, but whether it did or not, Archimedes

taught that a body immersed in a fluid lost apparent weight equal to the weight of the fluid displaced, called Archimedes' Principle. Specific gravity, the ratio of the density of a substance to the density of water, can be determined by weighing the body in air, and then in water. The specific gravity is the weight in air divided by the loss in weight when immersed. This avoids the difficult determination of the exact volume of the sample.

How Buoyancy Works

To see how buoyancy works, consider a submerged brick, of height h , width w and length l . The difference in pressure on top and bottom of the brick is ρgh , so the difference in total force on top and bottom of the brick is simply $(\rho gh)(wl) = \rho gV$, where V is the volume of the brick.

The forces on the sides have no vertical components, so they do not matter. The net upward force is the weight of a volume V of the fluid of density ρ . Anybody can be considered made up of brick shapes, as small as desired, so the result applies in general. This is just the integral calculus in action, or the application of Professor Thomson's analogy.

Change of Ship Stability

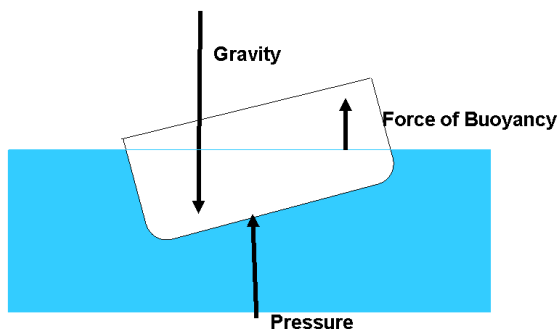

Consider a man in a rowboat on a lake, with a large rock in the boat. He throws the rock into the water. What is the effect on the water level of the lake? Suppose you make a drink of ice water with ice cubes floating in it. What happens to the water level in the glass when the ice has melted?

The force exerted by the water on the bottom of a boat acts through the centre of gravity B of the displaced volume, while the force exerted by gravity on the boat acts through its own centre of gravity A . This looks bad for the boat, since the boat's c.g. will naturally be higher than the c.g. of the displaced water, so the boat will tend to capsize.

Well, a board floats, and can tell us why. Should the board start to rotate to one side, the displaced volume immediately moves to that side, and the buoyant force tends to correct the rotation.

A floating body will be stable provided the line of action of the buoyant force passes through a point M above the c.g. of the body, called the metacentre, so that there is a restoring couple when the boat heels. A ship with an improperly designed hull will not float. It is not as easy to make boats as it might appear.

Montgolfier Brothers' Hot Air Balloon

Archimedes' Principle can also be applied to balloons. The Montgolfier brothers' hot air balloon with a paper envelope ascended first in 1783 (the brothers got Pilâtre de Rozier and Chevalier d'Arlandes to go up in it). Such "fire balloons" were then replaced with hydrogen-filled balloons, and then with balloons filled with coal gas, which was easier to obtain and did not diffuse through the envelope quite as rapidly. Methane would be a good filler, with a density 0.55 that of air. Slack balloons, like most large ones, can be contrasted with taut balloons with an elastic envelope, such as weather balloons. Slack balloons will not be filled full on the ground, and will plump up at altitude.

Balloons are naturally stable, since the center of buoyancy is above the center of gravity in all practical balloons. Submarines are yet another application of buoyancy, with their own characteristic problems. Small neoprene or natural rubber balloons have been used for meteorological observations, with hydrogen filling. A 10g ceiling balloon was about 17" in diameter when inflated to have a free lift of 40g. It ascended 480ft the first minute, 670ft in a minute and a half, and 360ft per minute afterwards, to find cloud ceilings by timing, up to 2500ft, when it subtended about 2' of arc, easily seen in binoculars.

Large sounding balloons were used to lift a radiosonde and a parachute for its recovery. An AN/AMT-2 radiosonde of the 1950's weighed 1500g, the paper parachute 100g, and the balloon 350g. The balloon was inflated to give 800g free lift, so it would rise 700-800 ft/min to an altitude of about 50,000 ft (15 km) before it burst. This balloon was about 6 ft in diameter when inflated at the surface, 3 ft in diameter before inflation. The information was returned by radio telemetry, so the balloon did not have to be followed optically. Of intermediate size was the pilot balloon, which was followed with a theodolite to determine wind directions and speeds. At night, a pilot balloon could carry a light for ceiling determinations.

Weather Balloons

The greatest problem with using hydrogen for lift is that it diffuses rapidly through many substances. Weather balloons had to be launched promptly after filling, or the desired free lift would not be obtained. Helium is a little better in this respect, but it also diffuses rapidly. The lift obtained with helium is almost the same as with hydrogen (density 4 compared to 2, where air is 28.97). However, helium is exceedingly rare, and only its unusual occurrence in natural gas from Kansas makes it available. Great care must be taken when filling balloons with hydrogen to avoid sparks and the accumulation of hydrogen in air, since hydrogen is exceedingly flammable and explosive over a wide range of concentrations. Helium has the great advantage that it is not inflammable.

The hydrogen for filling weather balloons came from compressed gas in cylinders, from the reaction of granulated aluminum with sodium hydroxide and water, or from the reaction of calcium hydroxide with water. The chemical reactions are $2Al + 2NaOH + 2H_2O \rightarrow 2NaAlO_2 + 3H_2$, or $CaH_2 + 2H_2O \rightarrow Ca(OH)_2 + 2H_2$. In the first, silicon or zinc could be used instead of aluminum, and in the second, any similar metal hydride. Both are rather expensive sources of hydrogen, but very convenient when only small amounts are required. Most hydrogen is made from the catalytic decomposition of hydrocarbons, or the reaction of hot coke with steam.

Electrolysis of water is an expensive source, since more energy is used than is recovered with the hydrogen. Any enthusiasm for a "hydrogen economy" should be tempered by the fact that there are no hydrogen wells, and all the hydrogen must be made with an input of energy usually greater than that available from the hydrogen, and often with the appearance of carbon.

Although about 60,000 Btu/lb is available from hydrogen, compared to 20,000 Btu/lb from gasoline, hydrogen compressed to 1000 psi requires 140 times as much volume for the same weight as gasoline. For the energy content of a 13-gallon gasoline tank, a 600-gallon hydrogen tank would be required. The critical temperature of hydrogen is 32K, so liquid storage is out of the question for general use.

Measurement of Specific Gravity

The specific gravity of a material is the ratio of the mass (or weight) of a certain sample of it to the mass (or weight) of an equal volume of water, the conventional reference material. In the metric system, the density of water is 1 g/cc, which makes the specific gravity numerically equal to the density. Strictly speaking, density has the dimensions g/cc, while specific gravity is a dimensionless ratio. However, in casual speech the two are often confounded.

In English units, however, density, perhaps in lb/cuft or pcf, is numerically different from the specific gravity, since the weight of water is 62.5 lb/cuft.

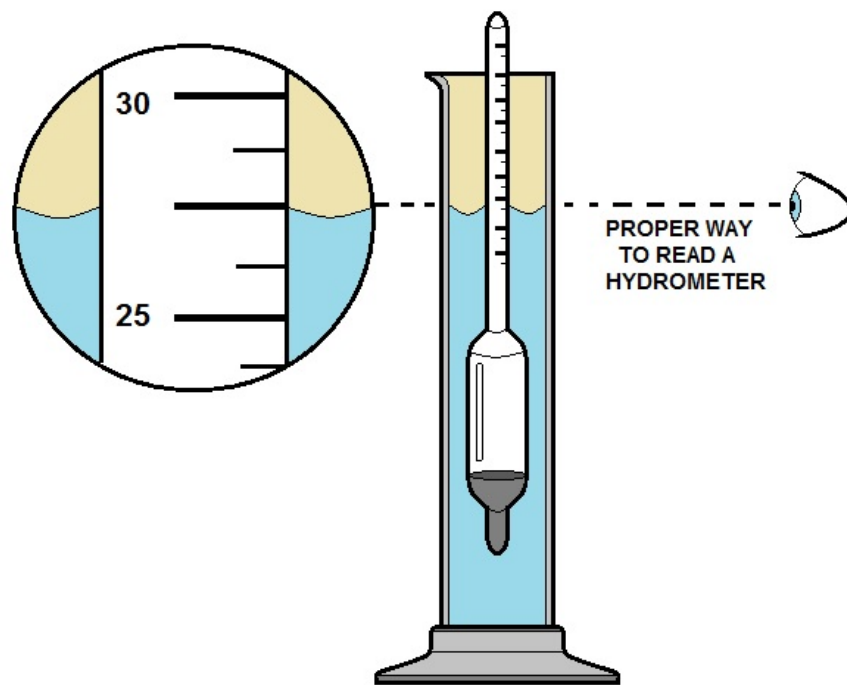

HYDROMETER

Variations

Things are complicated by the variation of the density of water with temperature, and also by the confusion that gave us the distinction between cc and ml. The milliliter is the volume of 1.0 g of water at 4°C, by definition. The actual volume of 1.0 g of water at 4°C is 0.999973 cm³ by measurement. Since most densities are not known, or needed, to more than three significant figures, it is clear that this difference is of no practical importance, and the ml can be taken equal to the cc. The density of water at 0°C is 0.99987 g/ml, at 20° 0.99823, and at 100°C 0.95838. The temperature dependence of the density may have to be taken into consideration in accurate work. Mercury, while we are at it, has a density 13.5955 at 0°C, and 13.5461 at 20°C.

The basic idea in finding specific gravity is to weigh a sample in air, and then immersed in water. Then the specific gravity is $W/(W - W')$, if W is the weight in air, and W' the weight immersed. The denominator is just the buoyant force, the weight of a volume of water equal to the volume of the sample. This can be carried out with an ordinary balance, but special balances, such as the Jolly balance, have been created specifically for this application. Adding an extra weight to the sample allows measurement of specific gravities less than 1.

Pycnometer

A pycnometer is a flask with a close-fitting ground glass stopper with a fine hole through it, so a given volume can be accurately obtained. The name comes from the Greek word meaning "density." If the flask is weighed empty, full of water, and full of a liquid whose specific gravity is desired, the specific gravity of the liquid can easily be calculated. A sample in the form of a powder, to which the usual method of weighing cannot be used, can be put into the pycnometer. The weight of the powder and the weight of the displaced water can be determined, and from them the specific gravity of the powder.

The specific gravity of a liquid can be found with a collection of small weighted, hollow spheres that will just float in certain specific gravities. The closest spheres that will just float and just sink put limits on the specific gravity of the liquid. This method was once used in Scotland to determine the amount of alcohol in distilled liquors. Since the density of a liquid decreases as the temperature increases, the spheres that float are an indication of the temperature of the liquid. Galileo's thermometer worked this way.

Hydrometer

A better instrument is the hydrometer, which consists of a weighted float and a calibrated stem that protrudes from the liquid when the float is entirely immersed. A higher specific gravity will result in a greater length of the stem above the surface, while a lower specific gravity will cause the hydrometer to float lower. The small cross-sectional area of the stem makes the instrument very sensitive. Of course, it must be calibrated against standards. In most cases, the graduations ("degrees") are arbitrary and reference is made to a table to determine the specific gravities. Hydrometers are used to determine the specific gravity of lead-acid battery electrolyte, and the concentration of antifreeze compounds in engine coolants, as well as the alcohol content of whiskey.

BRIX / BALLING HYDROMETER

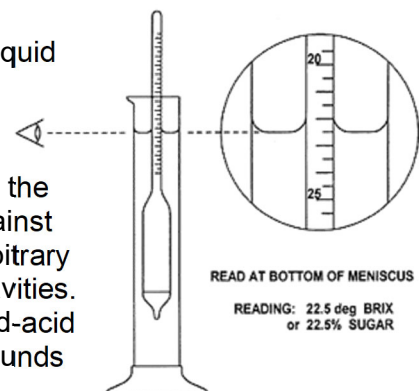

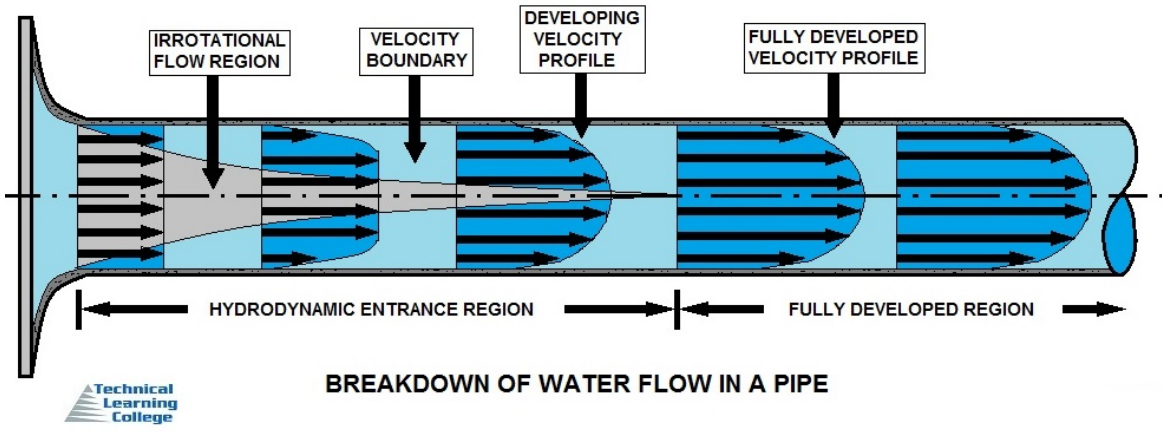

BREAKDOWN OF WATER FLOW IN A PIPE

Backflow Introduction

Backflow Prevention, also referred to as Cross-Connection Control, addresses a serious health issue. This issue was addressed on the federal level by passage of the "**Federal Safe Drinking Water Act**" as developed by the Environmental Protection Agency (E.P.A.) and passed into law on December 16, 1974.

This Act tasked each state with primary enforcement responsibility for a program to assure access to safe drinking water by all citizens. Such state program regulations as adopted are required to be at least as stringent as the federal regulations as developed and enforced by the E.P.A.

The official definition of a cross-connection is "**the link or channel connecting a source of pollution with a potable water supply.**" There are two distinct levels of concern with this issue. The first is protection of the general public and the second is protection of persons subject to such risks involving service to a single customer, be that customer an individual residence or business.

Sources of pollution which may result in a danger to health are not always obvious and such cross-connections are certainly not usually intentional. They are usually the result of oversight or a non-professional installation.

As source examples, within a business environment the pollutant source may involve the unintentional cross-connection of internal or external piping with chemical processes or a heating boiler.

In a residential environment, the pollutant source may be improper cross-connection with a landscape sprinkler system or reserve tank fire protection system. Or, a situation as simple as leaving a garden hose nozzle submerged in a bucket of liquid or attached to a chemical sprayer.

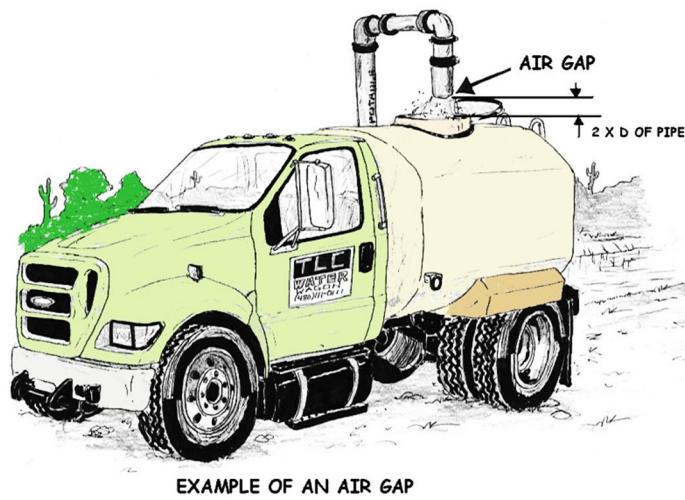

EXAMPLE OF AN AIR GAP

Another potential hazard source within any environment may be a cross-connection of piping involving a water well located on the property. This is a special concern with older residences or businesses, which may have been served by well water prior to connection to the developed water system.

There are many other potential sources of pollutant hazards. Control of cross-connections is possible but only through knowledge and vigilance. Public education is essential, for many that are educated in piping and plumbing installations fail to recognize cross-connection dangers.

Actual Backflow Events

Paraquat

In June 1983, "**yellow gushy stuff**" poured from some faucets in the Town of Woodsboro, Maryland. Town personnel notified the County Health Department and the State Water Supply Division. The State dispatched personnel to take water samples for analysis and placed a ban on drinking the Town's water.

Firefighters warned residents not to use the water for drinking, cooking, bathing, or any other purpose except flushing toilets. The Town began flushing its water system. An investigation revealed that the powerful agricultural herbicide Paraquat had backflowed into the Town's water system.

Someone left open a gate valve between an agricultural herbicide holding tank and the Town's water system and, thus, created a cross-connection. Coincidentally, water pressure in the Town temporarily decreased due to failure of a pump in the Town's water system. The herbicide Paraquat was backsiphoned into the Town's water system. Upon restoration of pressure in the Town's water system, Paraquat flowed throughout much of the Town's water system. Fortunately, this incident did not cause any serious illness or death. The incident did, however, create an expensive burden on the Town. Tanker trucks were used temporarily to provide potable water, and the Town flushed and sampled its water system extensively.

Mortuary

The chief plumbing inspector in a large southern city received a telephone call advising that blood was coming from drinking fountains at a mortuary (i.e., a funeral home). Plumbing and health inspectors went to the scene and found evidence that blood had been circulating in the potable water system within the funeral home. They immediately ordered the funeral home cut off from the public water system at the meter.

City water and plumbing officials did not think that the water contamination problem had spread beyond the funeral home, but they sent inspectors into the neighborhood to check for possible contamination. Investigation revealed that blood had backflowed through a hydraulic aspirator into the potable water system at the funeral home.

The funeral home had been using a hydraulic aspirator to drain fluids from bodies as part of the embalming process. The aspirator was directly connected to a faucet at a sink in the embalming room. Water flow through the aspirator created suction used to draw body fluids through a needle and hose attached to the aspirator.

When funeral home personnel used the aspirator during a period of low water pressure, the potable water system at the funeral home became contaminated. Instead of body fluids flowing into the wastewater system, they were drawn in the opposite direction--into the potable water system.

U.S. Environmental Protection Agency, Cross-Connection Control Manual, 1989

Recent Backflow Situations

Oregon 1993

Water from a drainage pond, used for lawn irrigation, is pumped into the potable water supply of a housing development.

California 1994

A defective backflow device in the water system of the County Courthouse apparently caused sodium nitrate contamination that sent 19 people to the hospital.

New York 1994

An 8-inch reduced pressure principle backflow assembly in the basement of a hospital discharged under backpressure conditions, dumping 100,000 gallons of water into the basement.

Nebraska 1994

While working on a chiller unit of an air conditioning system at a nursing home, a hole in the coil apparently allowed Freon to enter the circulating water, and from there into the city water system.

California 1994

The blue tinted water in a pond at an amusement park backflowed into the city water system and caused colored water to flow from homeowner's faucets.

California 1994

A film company shooting a commercial for television accidentally introduced a chemical into the potable water system.

Iowa 1994

A backflow of water from the Capitol Building chilled water system contaminates potable water with Freon.

Indiana 1994

Water main break caused a drop in water pressure, allowing anti-freeze from an air conditioning unit to backsiphon into the potable water supply.

Washington 1994

An Ethylene Glycol cooling system was illegally connected to the domestic water supply at a veterinarian hospital.

Ohio 1994

An ice machine connected to a sewer sickened dozens of people attending a convention.

2 REVERSE PRESSURE IS CAUSED BY A DROP IN WATER PRESSURE. THIS DROP CAN CAUSE CHEMICALS TO BE DRAWN INTO THE DRINKING WATER SUPPLY.

(This is referred to as: Cross Connection)

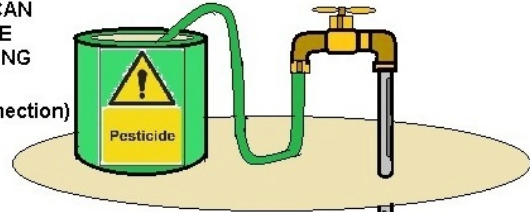

1 WATER PRESSURE IS REDUCED BY BREAK IN MAIN WATER SUPPLY

MAIN WATER SUPPLY



3 THESE CHEMICALS ENTER DRINKING WATER SUPPLY AND CAN CAUSE SERIOUS CONTAMINATION WHICH CAN ILLNESSES OR FATALITIES



Cross-Connection Terms

Cross-connection

A cross-connection is any temporary or permanent connection between a public water system or consumer's potable (i.e., drinking) water system and any source or system containing nonpotable water or other substances. An example is the piping between a public water system or consumer's potable water system and an auxiliary water system, cooling system, or irrigation system.

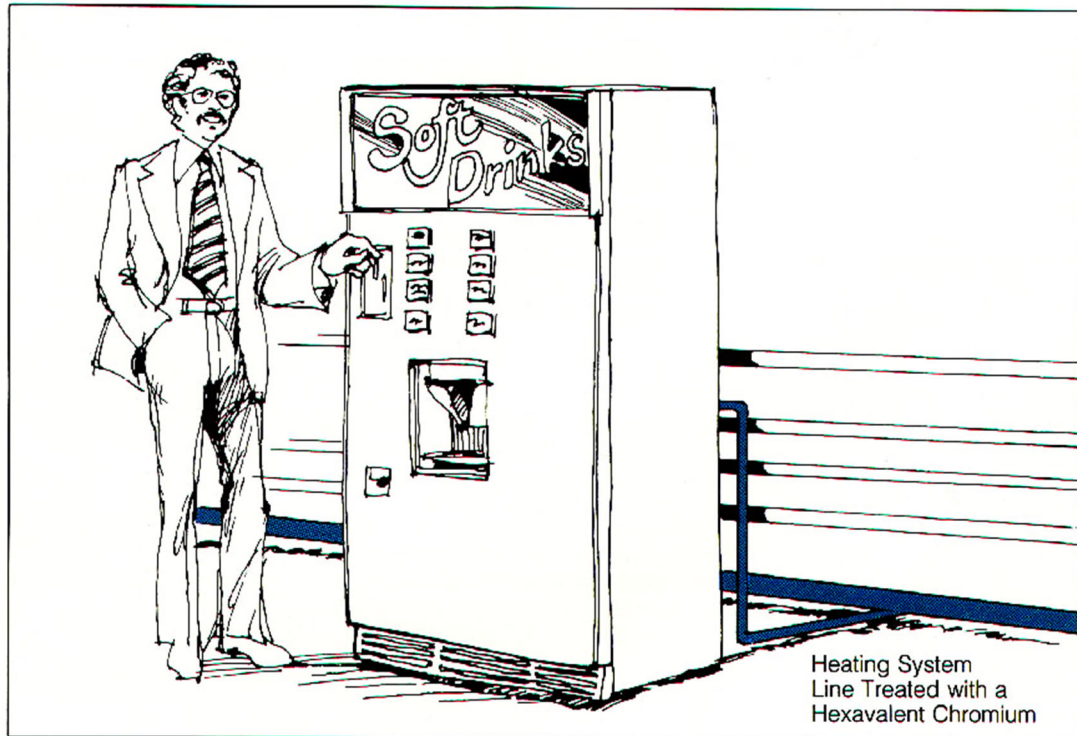

Several cross-connection have been made to soda machines, the one to worry about is when you have a copper water line hooked to CO₂ without a backflow preventer. The reason is that the CO₂ will mix in the water and create copper carbonic acid, which is deadly. This is one reason that you will see clear plastic lines at most soda machines and no copper lines. Most codes require a stainless steel RP backflow assembly at soda machines.

Common Cross-Connections

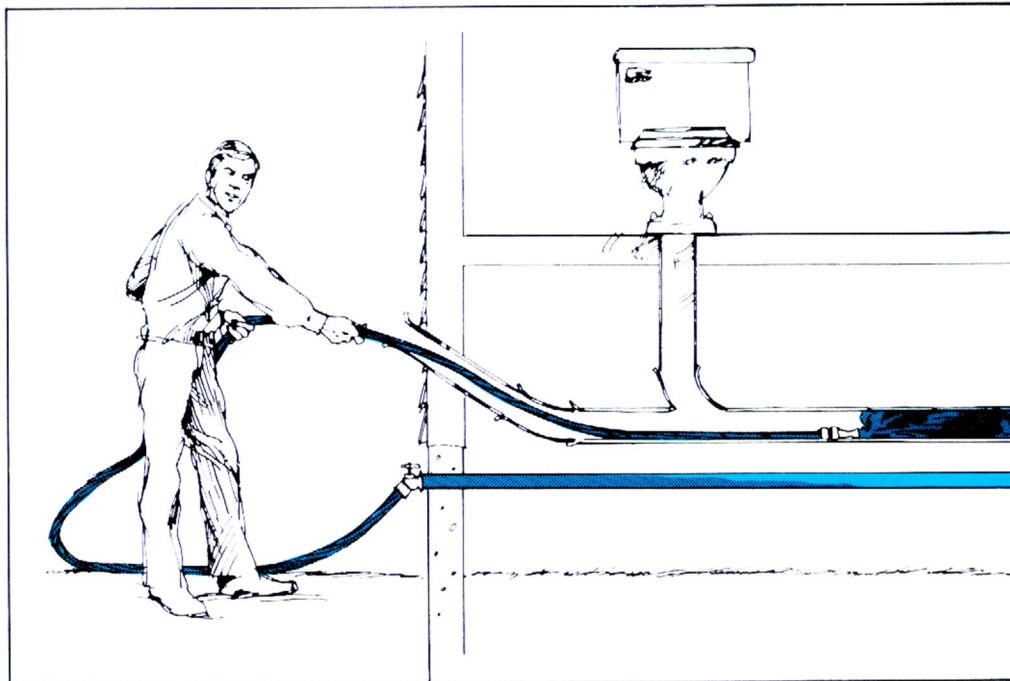
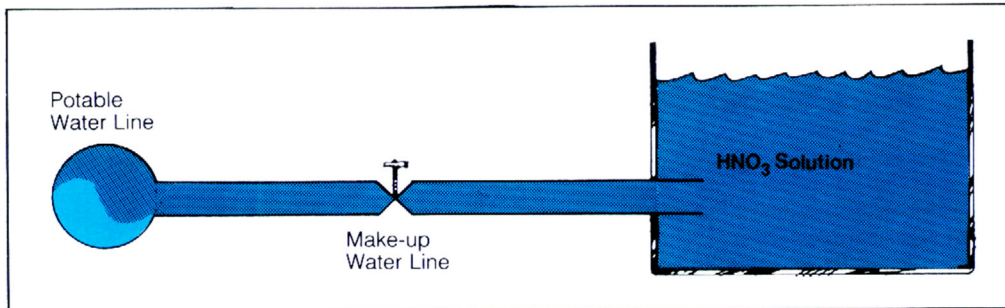
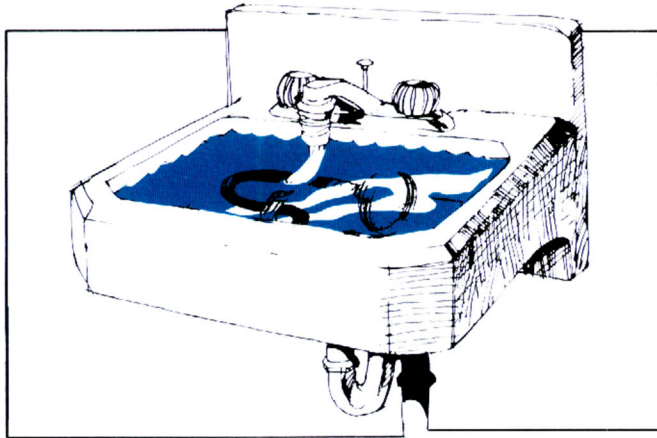

Backflow

Backflow is the undesirable reversal of flow of nonpotable water or other substances through a cross-connection and into the piping of a public water system or consumer's potable water system. There are two types of backflow--**backpressure** and **backsiphonage**.

Backsiphonage

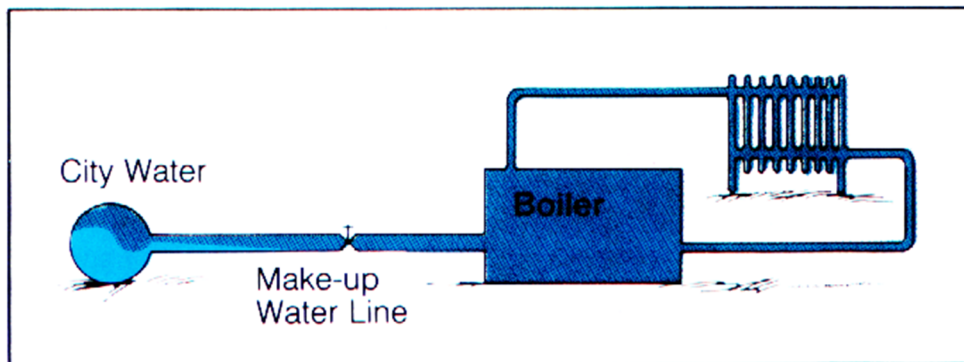

Example of backpressure being caused by heat.

Backsiphonage

Backsiphonage is backflow caused by a negative pressure (i.e., a vacuum or partial vacuum) in a public water system or consumer's potable water system. The effect is similar to drinking water through a straw.

Backsiphonage can occur when there is a stoppage of water supply due to nearby firefighting, a break in a water main, etc.

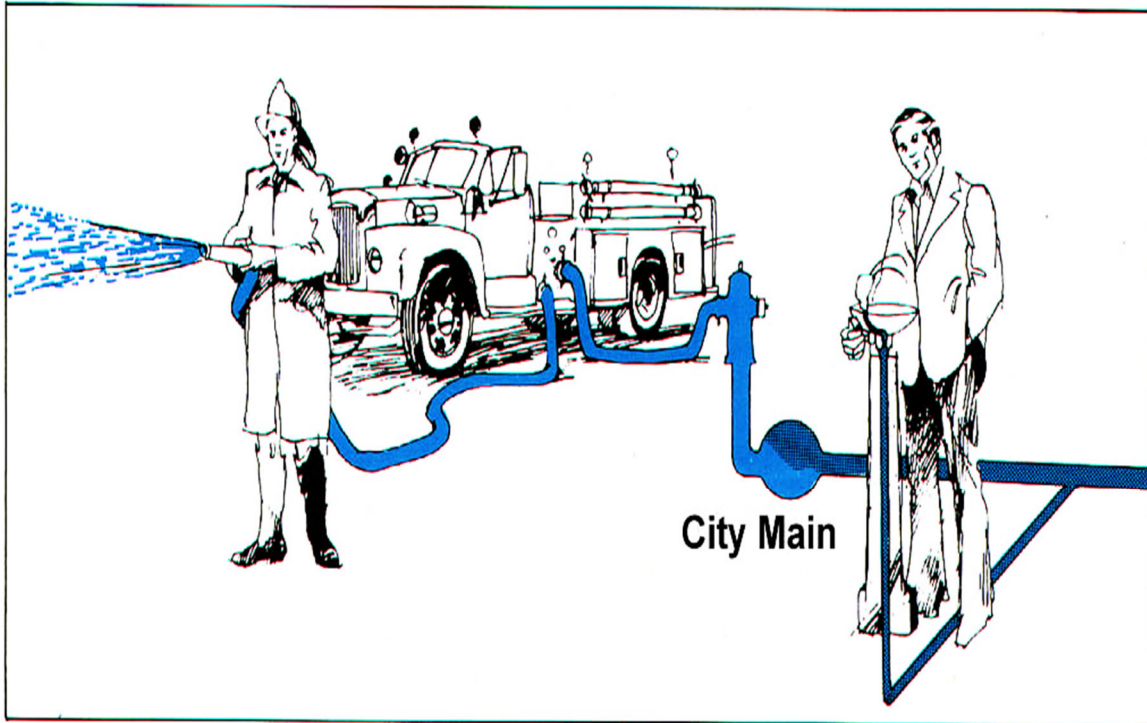

Every day, our public water system has several backsiphonage occurrences. Think of people that use water driven equipment from a device that drains water beds to pesticide applicators.

Backpressure is rarer but does happen in areas of high elevation, like tall buildings or building with pumps. A good example is the pressure exerted by a building that is 100 feet tall is about 43 PSI; the water main feeding the building is at 35 PSI.

The water will flow back to the water main. Never drink water or coffee inside a funeral home, vet clinic or hospital. Think about the plumbing system!

Backpressure

Backpressure backflow is backflow caused by a downstream pressure that is greater than the upstream or supply pressure in a public water system or consumer's potable water system. Backpressure (i.e., downstream pressure that is greater than the potable water supply pressure) can result from an increase in downstream pressure, a reduction in the potable water supply pressure, or a combination of both. Increases in downstream pressure can be created by pumps, temperature increases in boilers, etc.

Reductions in potable water supply pressure occur whenever the amount of water being used exceeds the amount of water being supplied, such as during water line flushing, firefighting, or breaks in water mains.

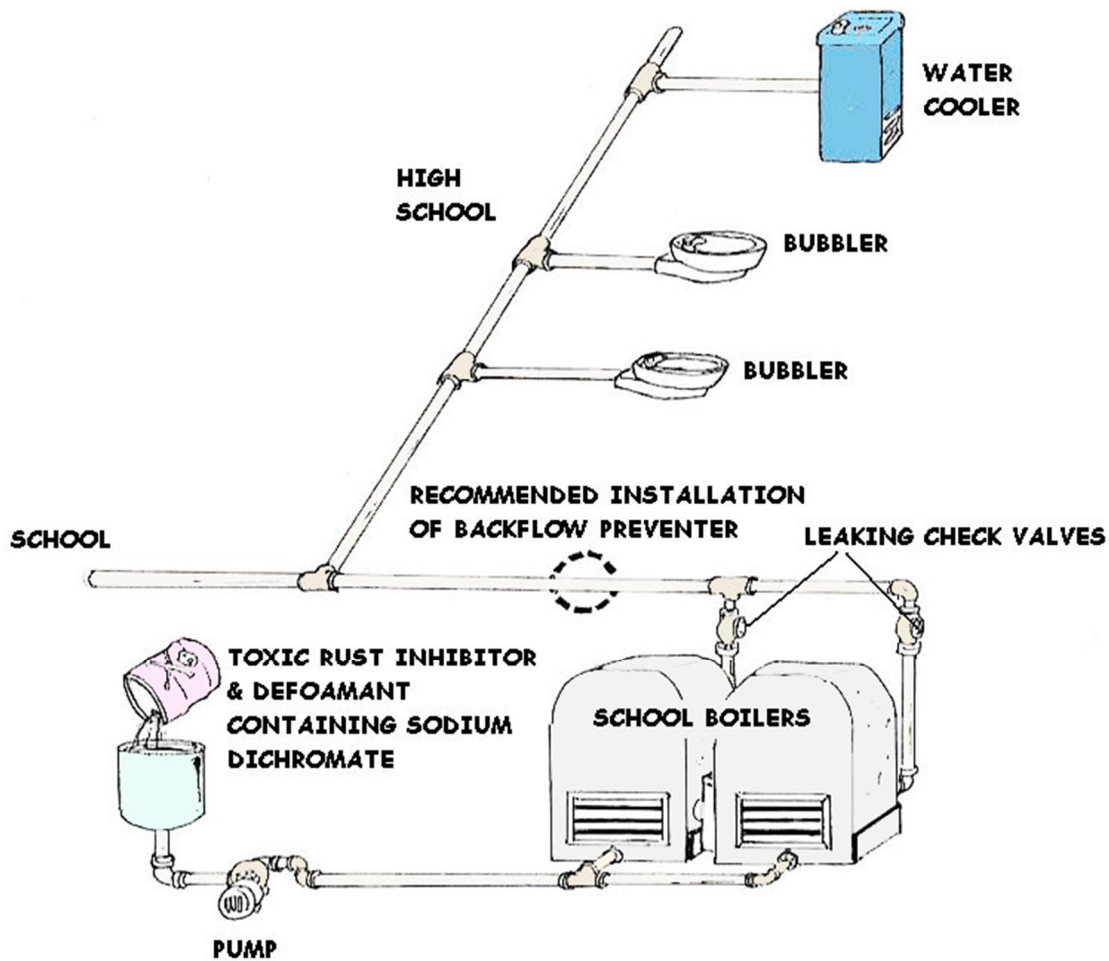

Backpressure Examples

Booster pumps, pressure vessels, elevation, heat

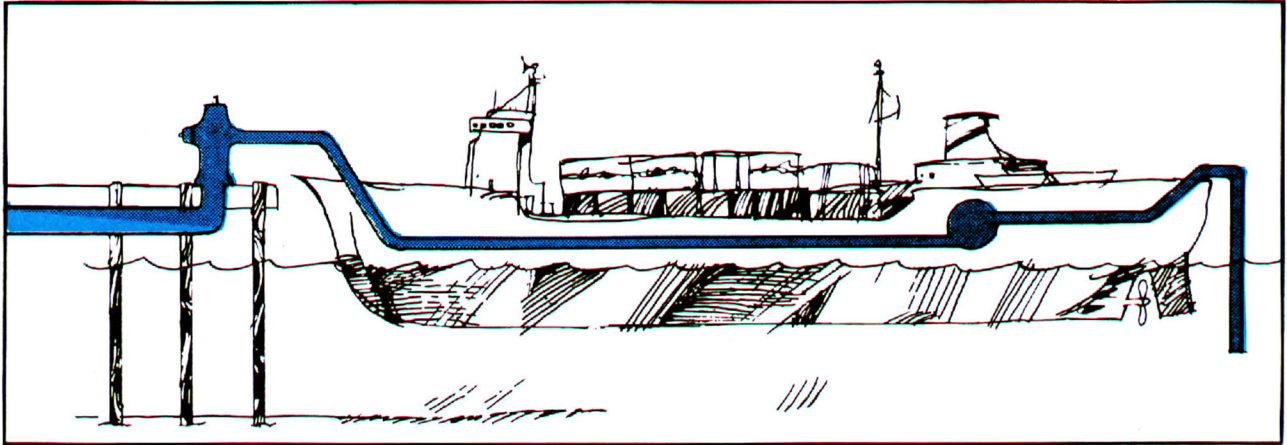

Here we see the backpressure of salt water back into the public water system from a ship's pressure pump. Most water providers are now requiring a RP assembly at the hydrant.

What is a backflow preventer?

A backflow preventer is a means or mechanism to prevent backflow. The basic means of preventing backflow is an air gap, which either eliminates a cross-connection or provides a barrier to backflow.

The basic mechanism for preventing backflow is a mechanical backflow preventer, which provides a physical barrier to backflow.

The principal types of mechanical backflow preventer are the reduced-pressure principle assembly, the pressure vacuum breaker assembly, and the double check valve assembly.

Residential Dual Check Valve

A secondary type of mechanical backflow preventer is the residential dual check valve. We do not recommend the installation of dual checks because there is no testing method or schedule for these devices.

Once these devices are in place, they, like all mechanical devices, are subject to failure and will probably be stuck open. Some type of debris will keep the device from working properly.

Types of Backflow Prevention Methods and Assemblies

Backflow Devices

Cross connections must either be physically disconnected or have an approved backflow prevention device installed to protect the public water system. There are five types of approved devices/methods:

1. **Air gap- *Is not really a device but is a method.***
2. **Atmospheric vacuum breaker**
3. **Pressure vacuum breaker**
4. **Double check valve**
5. **Reduced pressure principle backflow preventer (RP device)**

The type of device selected for a particular installation depends on several factors. First, the degree of hazard must be assessed. A high hazard facility is one in which a cross connection could be hazardous to health, such as a chrome plating shop or a sewage treatment plant. A low hazard situation is one in which a cross connection would cause only an aesthetic problem such as a foul taste or odor.

Second, the plumbing arrangement must be considered.

Third, it must be determined whether protection is needed at the water meter or at a location within the facility.

Approved Air Gap Separation (AG)

An approved air gap is a physical separation between the free flowing discharge end of a potable water supply pipeline, and the overflow rim of an open or non- pressure receiving vessel. These separations must be vertically orientated a distance of at least twice the inside diameter of the inlet pipe, but never less than one inch.

An obstruction around or near an air gap may restrict the flow of air into the outlet pipe and nullify the effectiveness of the air gap to prevent backsiphonage.

When the air flow is restricted, such as the case of an air gap located near a wall, the air gap separation must be increased.

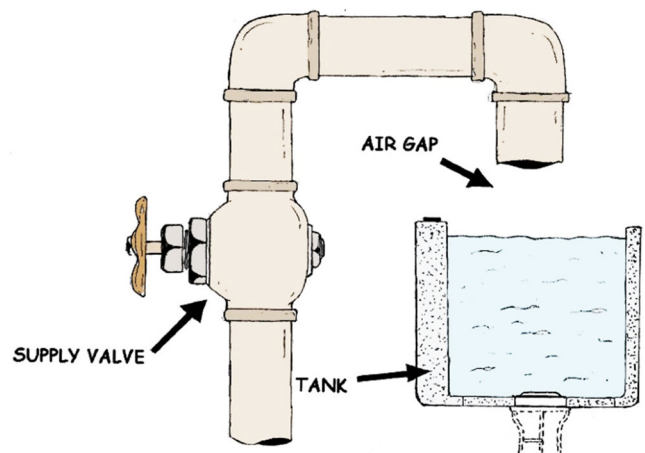



Which of these ice machine drains have an approved air gap?

Air Gap

An air gap is a physical disconnection between the free flowing discharge end of a potable water pipeline and the top of an open receiving vessel.

The air gap must be at least two times the diameter of the supply pipe and not less than one inch.

This type of protection is acceptable for high hazard installations and is theoretically the most effective protection.

However, this method of prevention can be circumvented if the supply pipe is extended.

Atmospheric Vacuum Breaker (AVB)



The Atmospheric Vacuum Breaker contains a float check (poppet), a check seat, and an air inlet port. The device allows air to enter the water line when the line pressure is reduced to a gauge pressure of zero or below. The air inlet valve is not internally loaded. To prevent the air inlet from sticking closed, the device must not be installed on the pressure side of a shutoff valve, or wherever it may be under constant pressure more than 12 hours during a 24 hour period.

Atmospheric vacuum breakers are designed to prevent backflow caused by backsiphonage only from low health hazards.

Atmospheric Vacuum Breaker Uses: Irrigation systems, commercial dishwasher and laundry equipment, chemical tanks and laboratory sinks (backsiphonage only, non-pressurized connections)

(Note: hazard relates to the water purveyor's risk assessment; plumbing codes may allow AVB for high hazard fixture isolation).

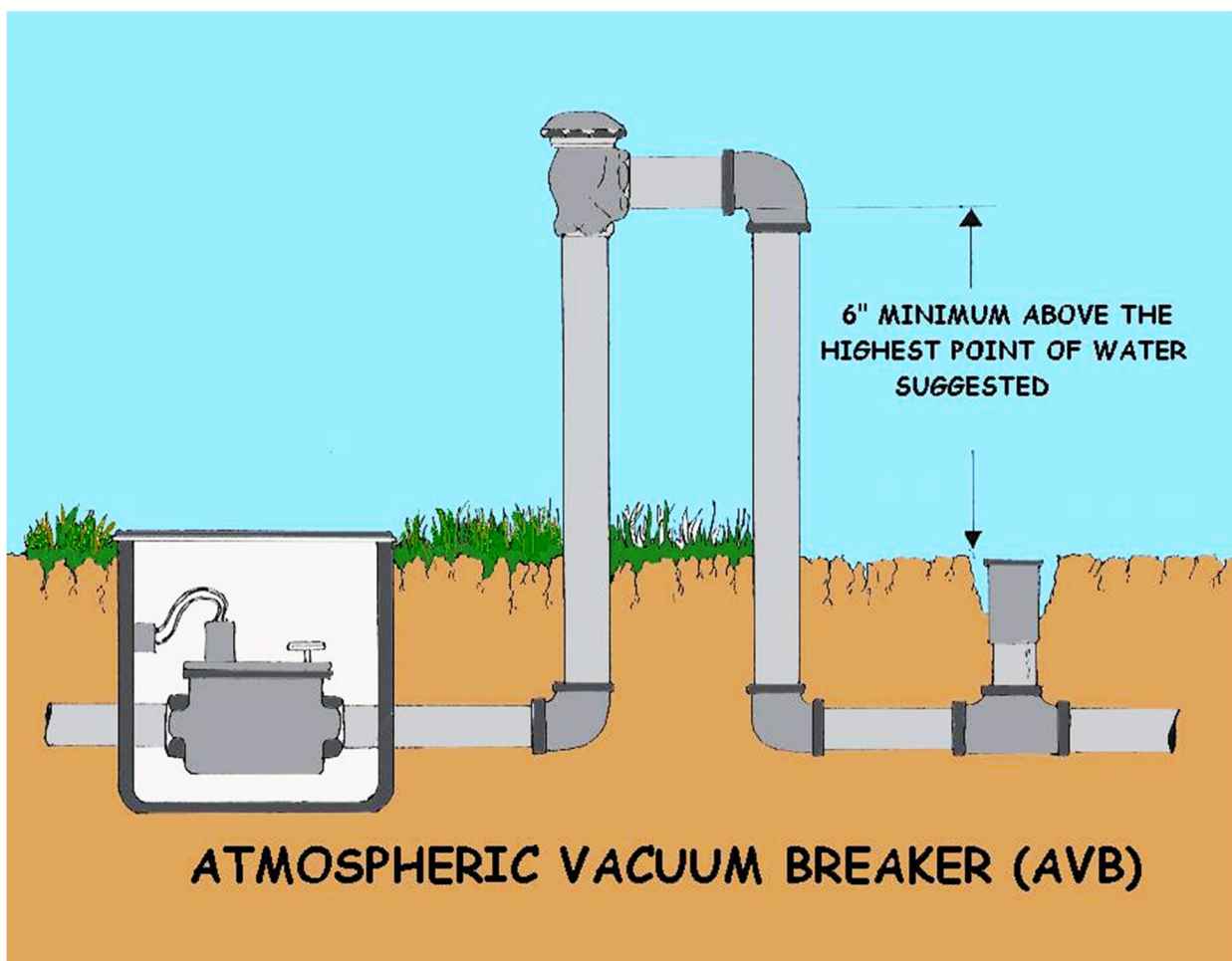

Pressure Vacuum Breaker Assembly (PVB)

The Pressure Vacuum Breaker Assembly consists of a spring loaded check valve, an independently operating air inlet valve, two resilient seated shutoff valves, and two properly located resilient seated test cocks. It shall be installed as a unit as shipped by the manufacturer. The air inlet valve is internally loaded to the open position, normally by means of a spring, allowing installation of the assembly on the pressure side of a shutoff valve.



PRESSURE VACUUM BREAKER ASSEMBLY

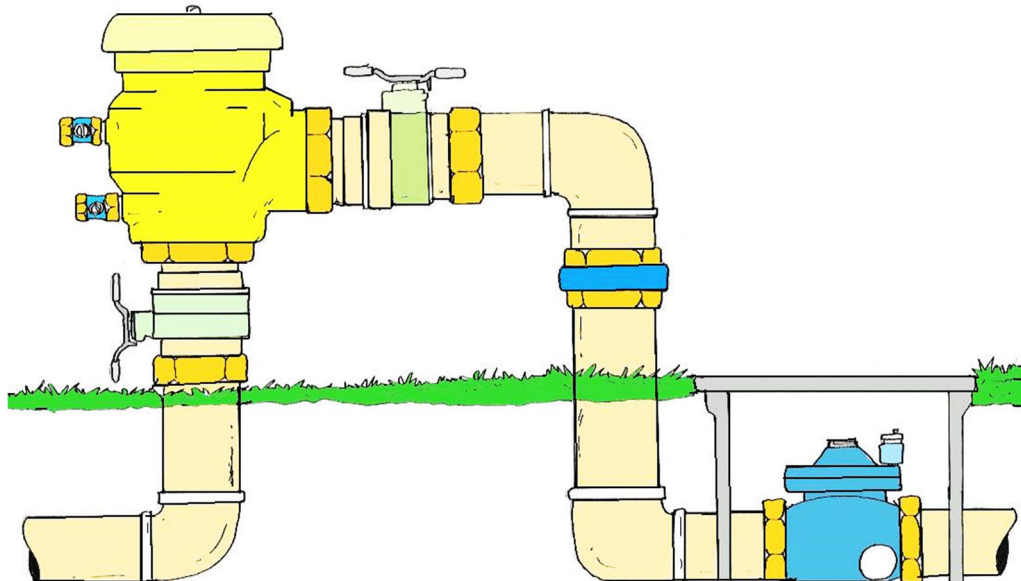

Double Check Valve Assembly (DC)

The Double Check Valve Assembly consists of two internally loaded check valves, either spring loaded or internally weighted, two resilient seated full ported shutoff valves, and four properly located resilient seated test cocks. This assembly shall be installed as a unit as shipped by the manufacturer. The double check valve assembly is designed to prevent backflow caused by backpressure and backsiphonage from low health hazards.



Reduced Pressure Backflow Assembly (RP)

The reduced pressure backflow assembly consists of two independently acting spring loaded check valves separated by a spring loaded differential pressure relief valve, two resilient seated full ported shutoff valves, and four properly located resilient seated test cocks. This assembly shall be installed as a unit shipped by the manufacturer.

During normal operation, the pressure between the two check valves, referred to as the zone of reduced pressure, is maintained at a lower pressure than the supply pressure. If either check valve leaks, the differential pressure relief valve maintains a differential pressure of at least two (2) psi between the supply pressure, and the zone between the two check valves by discharging water to atmosphere.

The reduced pressure backflow assembly is designed to prevent backflow caused by backpressure and backsiphonage from low to high health hazards. The RP needs to be installed 12 inches above the ground for testing purposes only.

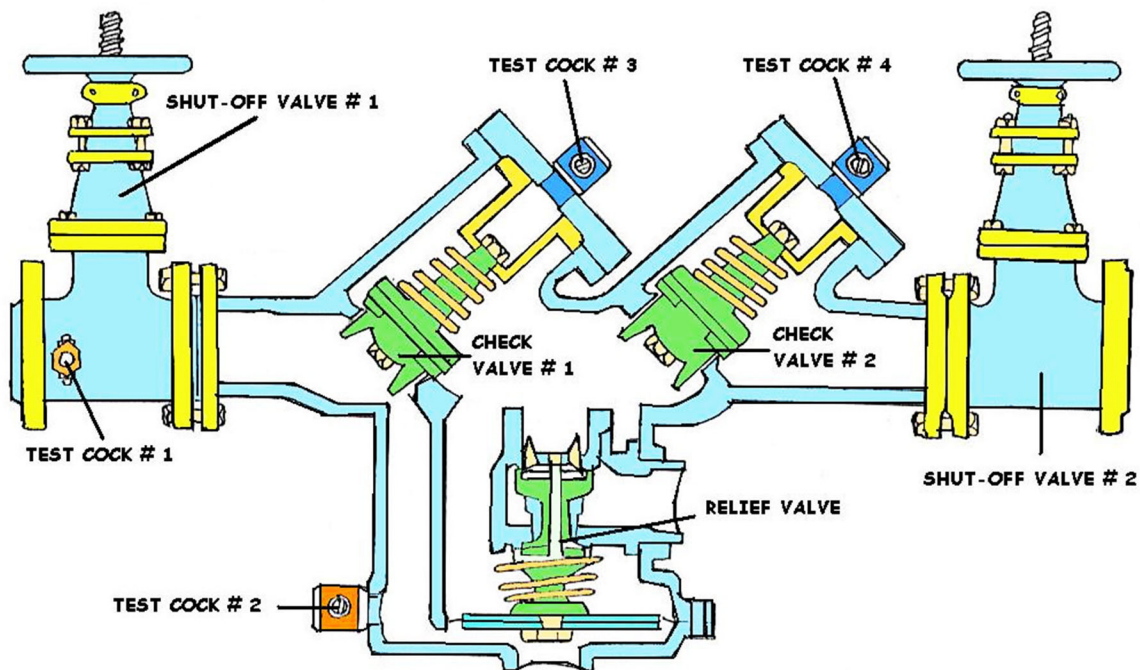

REDUCED-PRESSURE BACKFLOW ASSEMBLY

Different Styles of RPs

The RP consists of two internally loaded (weighted or spring loaded) check valves separated by a reduced pressure zone with a relief port to vent water to the atmosphere.

The reduced pressure device can be used for high hazard situations under both backpressure and backsiphonage conditions. Under normal conditions, the second check valve should prevent backflow.

However, if the second check valve fails or becomes fouled and backflow into the reduced pressure zone occurs, the relief port vents the backflow to atmosphere.

The reduced pressure zone port opens anytime pressure in the zone comes within 2 psi of the supply pressure.

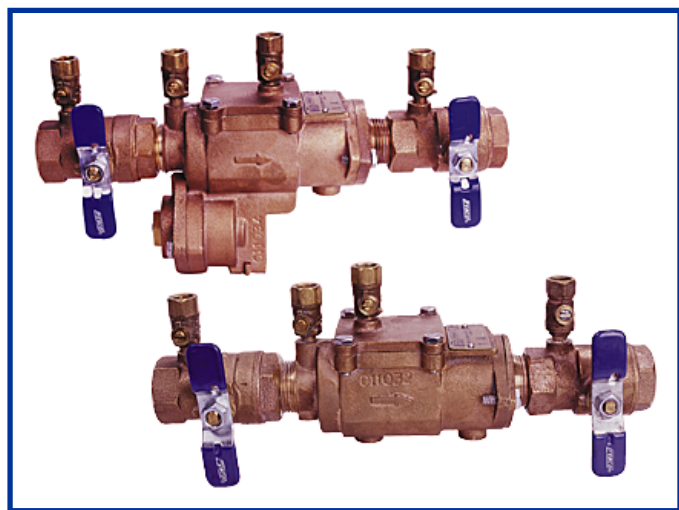
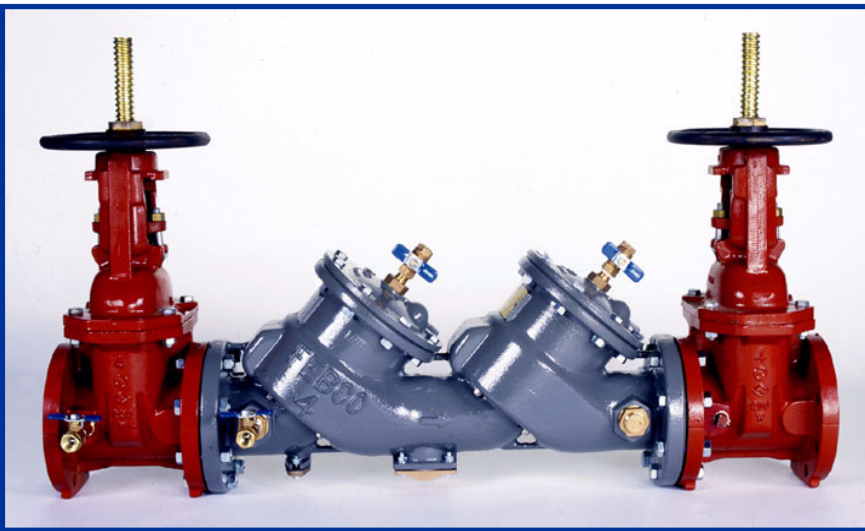

Why do Backflow Preventors have to be Tested Periodically?

Mechanical backflow preventors have internal seals, springs, and moving parts that are subject to fouling, wear, or fatigue. Also, mechanical backflow preventors and air gaps can be bypassed. Therefore, all backflow preventors have to be tested periodically to ensure that they are functioning properly. A visual check of air gaps is sufficient, but mechanical backflow preventors have to be tested with properly calibrated gauge equipment.

Backflow prevention devices must be tested annually to ensure that they work properly. It is usually the responsibility of the property owner to have this test done and to make sure that a copy of the test report is sent to the Public Works Department or Water Purveyor.

If a device is not tested annually, Public Works or the Water Purveyor will notify the property owner asking them to comply. If the property owner does not voluntarily test their device, the City may be forced to turn off water service to that property. State law requires the City to discontinue water service until testing is complete.



Leaky RP--have your assemblies tested annually or more often. Re-test after repairs and problems. A RP should not leak more that 1 or 2 minutes any more than that, there is a problem, a piece of debris or a stuck check is causing this RP's hydraulic relief port to dump.

Distribution Section



A **water supply system** or **distribution system** is a system of engineered hydrologic and hydraulic components which provide water supply. A water supply system typically includes:

1. A raw water collection point (above or below ground) where the water accumulates, such as a lake, a river, or groundwater from an underground aquifer. Raw water may be transferred using uncovered ground-level aqueducts, covered tunnels or underground water pipes to water treatment facilities.
2. Water treatment facilities. Treated water is transferred using water pipes (usually underground). We will examine these water pipe and valves.
3. Water storage facilities such as reservoirs, water tanks, or water towers. Smaller water systems may store the water in cisterns or pressure vessels. Tall buildings may also need to store water locally in pressure vessels in order for the water to reach the upper floors.
4. Additional water pressurizing components such as pumping stations may need to be situated at the outlet of underground or above ground reservoirs or cisterns (if gravity flow is impractical).
5. A interconnecting pipe network for distribution of water to the consumers (which may be private houses or industrial, commercial or institution establishments) and other usage points (such as fire hydrants). We will examine these components in detail.
6. Connections to the sewer collection system (underground pipes, or aboveground ditches in some developing countries) are generally found downstream of the water consumers, but the sewer system is considered to be a separate system, rather than part of the water supply system.

Corrosion

As water passes through the distribution system, the water quality can degrade by chemical reactions and biological processes. Corrosion of metal pipe materials in the distribution system can cause the release of metals into the water with undesirable aesthetic and health effects. Release of iron from unlined iron pipes can result in customer reports of "red water" at the tap. Release of copper from copper pipes can result in customer reports of "blue water" and/or a metallic taste. Release of lead can occur from the solder used to join copper pipe together or from brass fixtures. Copper and lead levels at the consumer's tap are regulated to protect consumer health.

Utilities will often adjust the chemistry of the water before distribution to minimize its corrosiveness. The simplest adjustment involves control of pH and alkalinity to produce a water that tends to passivate corrosion by depositing a layer of calcium carbonate. Corrosion inhibitors are often added to reduce release of metals into the water. Common corrosion inhibitors added to the water are phosphates and silicates.

Maintenance of a biologically safe drinking water is another goal in water distribution. Typically, a chlorine based disinfectant, such as sodium hypochlorite or monochloramine is added to the water as it leaves the treatment plant. Booster stations can be placed within the distribution system to ensure that all areas of the distribution system have adequate sustained levels of disinfection.

Minimum Storage

Minimum storage available for *public fire protection* should be examined in terms of the type of distribution system. It may be helpful to refer to the figures illustrating basic types of water systems. Every water system for communities over 50 population has to have a water storage component in order to provide even minimum *fire protection water supplies*.

The amount of water in storage for a given distribution system is constantly changing due to residential, business, and industrial consumption and, as needed, *Fire-flow consumption*. As previously identified, consumption varies by the time of the day and the day of the week.

197. Consequently, finished water (referring to water that has been suitably treated to meet EPA Safe Drinking Water Standards), in storage also varies by the time of day and the day of the week. The insurance community grading process is interested in the *average minimum storage* as a benchmark for both water system adequacy and reliability.

To determine minimum storage, it is necessary to maintain accurate records on storage facilities including clear wells, standpipe tanks, and *Gravity tanks*. Chart recorders linked to each storage facility typically are used to cover the capacity range of the specific *Storage tank*.

The recorded minimum amount of water in storage for each day is expressed in gallons or millions of gallons.

For each year being evaluated, all daily minimum amounts are totaled and divided by 365 days to provide the average minimum water in *Storage*.

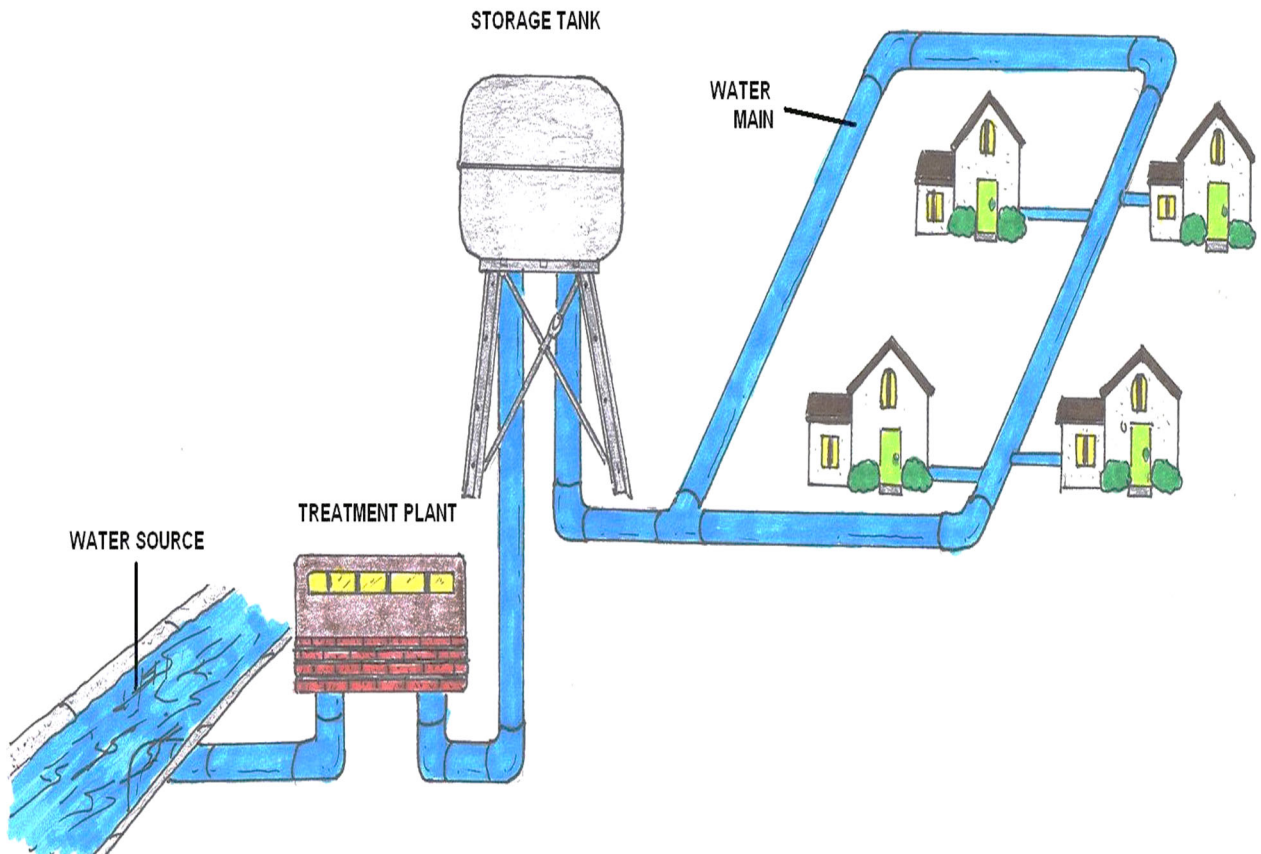

WATER SUPPLY DISTRIBUTION SYSTEM

Schematic of a Large Transmission Distribution System

The diagram above shows a typical large main or transmission distribution system. The water flows from the treatment plant into a storage reservoir. Although not every system will have a storage reservoir, it is advisable to separate stored water and source water in order to have better hydraulic flows and a more dependable system. In this case, we have an elevated storage tank.

From the storage reservoir, water flows or is pumped as needed out into the mains which carry large quantities of water toward the customer. Water is diverted to feed fire hydrants off smaller mains. Other water flows from the mains into the service lines which carry the water to the customers.

Booster stations are used to pump water where the water pressure is lower than in the rest of the system. Meters measure the flow of water through the system located at customer services.

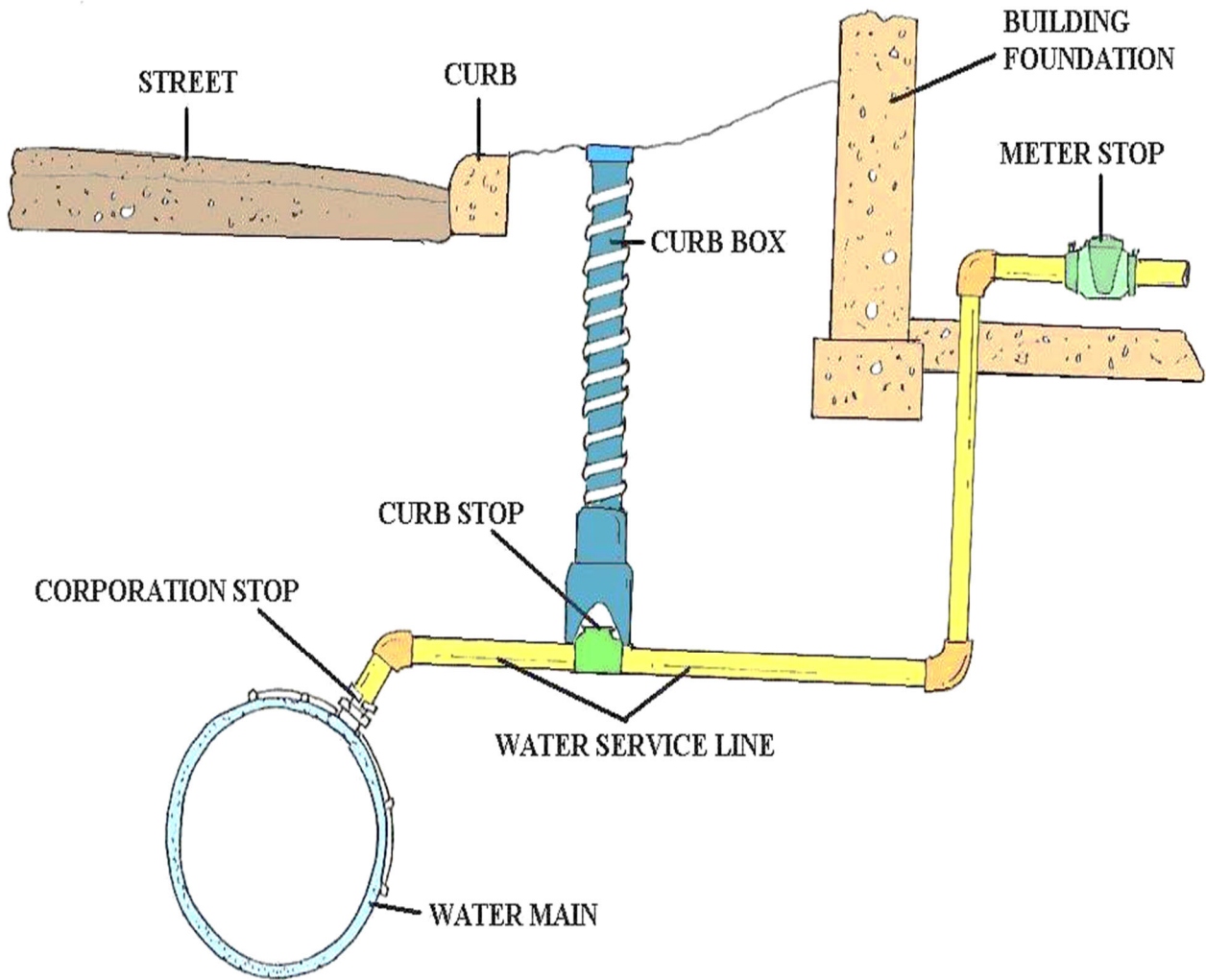

What Is the Distribution Purpose?

The water distribution system is the essential link between the water supply source and the consumer. It is not just the main that runs down your street, quite the contrary. It is an elaborate conveyance system that allows water to be moved through miles of piping before reaching your tap.

Pumps allow water to move through the system; valves allow water pressure and flow direction to be regulated along the way.

The Water Distribution is generally responsible for the maintenance of water mains, water services, fire hydrants, water valves and backflow devices located within your City's/Water Provider's service area. In short, the Distribution Division ensures that treated water is delivered to your tap.

New EPA Rules for Distribution Reduction of Lead in Drinking Water Act

Congress passed Public Law 111-380 or The Reduction of Lead in Drinking Water Act, in 2010. Effective Jan. 4, 2014.

Lead, a metal found in natural deposits, is commonly used in household plumbing materials and water service lines. The greatest exposure to lead is swallowing or breathing in lead paint chips and dust.

But lead in drinking water can also cause a variety of adverse health effects. In babies and children, exposure to lead in drinking water above the action level can result in delays in physical and mental development, along with slight deficits in attention span and learning abilities. In adults, it can cause increases in blood pressure. Adults who drink this water over many years could develop kidney problems or high blood pressure.

Lead is rarely found in source water, but enters tap water through corrosion of plumbing materials. Homes built before 1986 are more likely to have lead pipes, fixtures and solder. However, new homes are also at risk: even legally “lead-free” plumbing may contain up to 8 percent lead. The most common problem is with brass or chrome-plated brass faucets and fixtures which can leach significant amounts of lead into the water, especially hot water.

Congress enacted the Reduction of Lead in Drinking Water Act on January 4, 2011, to amend Section 1417 of the Safe Drinking Water Act (SDWA) regarding the use and introduction into commerce of lead pipes, plumbing fittings or fixtures, solder and flux.

Pervasive Environmental Contaminant

Lead is a pervasive environmental contaminant. The adverse health effects of lead exposure in children and adults are well documented, and no safe blood lead threshold in children has been identified. Lead can be ingested from various sources, including lead paint and house dust contaminated by lead paint, as well as soil, drinking water, and food. The concentration of lead, total amount of lead consumed, and duration of lead exposure influence the severity of health effects. Because lead accumulates in the body, all sources of lead should be controlled or eliminated to prevent childhood lead poisoning.

Beginning in the 1970s, lead concentrations in air, tap water, food, dust, and soil began to be substantially reduced, resulting in significantly reduced blood lead levels (BLLs) in children throughout the United States.

However, children are still being exposed to lead, and many of these children live in housing built before the 1978 ban on lead-based residential paint. These homes might contain lead paint hazards, as well as drinking water service lines made from lead, lead solder, or plumbing materials that contain lead. Adequate corrosion control reduces the leaching of lead plumbing components or solder into drinking water.

The majority of public water utilities are in compliance with the Safe Drinking Water Act Lead and Copper Rule (LCR) of 1991.

However, some children are still exposed to lead in drinking water. EPA is reviewing LCR, and additional changes to the rule are expected that will further protect public health. Childhood lead poisoning prevention programs should be made aware of the results of local public water system lead monitoring measurement under LCR and consider drinking water as a potential cause of increased BLLs, especially when other sources of lead exposure are not identified.

This review describes a selection of peer-reviewed publications on childhood lead poisoning, sources of lead exposure for adults and children, particularly children aged <6 years, and LCR. What is known and unknown about tap water as a source of lead exposure is summarized, and ways that children might be exposed to lead in drinking water are identified.

This report does not provide a comprehensive review of the current scientific literature but builds on other comprehensive reviews, including the *Toxicological Profile for Lead* and the 2005 CDC statement *Preventing Lead Poisoning Among Young Children*). When investigating cases of children with BLLs at or above the reference value established as the 97.5 percentile of the distribution of BLLs in U.S. children aged 1–5 years, drinking water should be considered as a source. The recent recommendations from the CDC Advisory Committee on Childhood Lead Poisoning Prevention to reduce or eliminate lead sources for children before they are exposed underscore the need to reduce lead concentrations in drinking water as much as possible.

Background

Lead is a relatively corrosion-resistant, dense, ductile, and malleable metal that has been used by humans for at least 5,000 years. During this time, lead production has increased from an estimated 10 tons per year to 1,000,000 tons per year, accompanying population and economic growth. The estimated average BLL for Native Americans before European settlement in the Americas was calculated as 0.016 $\mu\text{g}/\text{dL}$.

During 1999–2004, the estimated average BLL was 1.9 $\mu\text{g}/\text{dL}$ for the non-institutionalized population aged 1–5 years in the United States, approximately 100 times higher than ancient background levels, indicating that substantial sources of lead exposure exist in the environment.

January 4, 2014

On January 4, 2014, the "Reduction of Lead in Drinking Water Act" becomes effective nationwide. This amendment to the 1974 Safe Drinking Water Act reduces the allowable lead content of drinking water pipes, pipe fittings and other plumbing fixtures. Specifically, as of January 4, 2014, it shall be illegal to install pipes, pipe fittings, and other plumbing fixtures that are not "lead free." "Lead free" is defined as restricting the permissible levels of lead in the wetted surfaces of pipes, pipe fittings, other plumbing fittings and fixtures to a weighted average of not more than 0.25%.

This new requirement does not apply to pipes, pipe fittings, plumbing fittings or fixtures that are used exclusively for non-potable services such as manufacturing, industrial processing, irrigation, outdoor watering, or any other uses where water is not anticipated to be used for human consumption.

The law also excludes toilets, bidets, urinals, fill valves, flushometer valves, tub fillers, shower valves, service saddles, or water distribution main gate valves that are 2 inches in diameter or larger.

Accordingly, effective January 4, 2014, only accepted products that are "lead free" may be utilized with regards to any plumbing providing water for human consumption (unless meeting the exception outlined above). Installers and inspectors may check their products to determine if they meet these requirements by looking to see if the products are certified to the following standards:

- A. NSF/ANSI 61-G;
- B. NSF/ANSI 61, section 9-G; OR
- C. Both NSF/ANSI 61 AND NSF/ANSI 372.

As existing products may still be utilized for non-potable purposes. The burden of following these requirements shall be on installers. Plumbing inspectors (who will be covering these requirements in continuing education) shall have the right to question installers, who must be able to prove that no non-compliant products are installed on or after January 4, 2014.

What does the law say?

It reduces the maximum amount of lead that can be used in the wetted surfaces of service brass from 8 percent to 0.25 percent. It prohibits the sale of traditional brass pipe fittings, valves and meters for potable water applications as well as their installation after Jan. 4, 2014.

Does The Reduction of Lead in Drinking Water Act apply to all water infrastructure?

No. Service brass used in industrial or non-potable infrastructure is exempt from the law. Also, the law only applies to wetted surfaces. Saddles and other exterior pipe are also exempt.

Are there any exceptions to the New Regulations?

Exceptions to the new lead-free law include: pipes, pipe fittings, plumbing fittings, or fixtures, including backflow preventers, that are used exclusively for non-potable services such as manufacturing, industrial processing, irrigation, outdoor watering, or any other uses where the water is not anticipated to be used for human consumption. In addition, toilets, bidets, urinals, fill valves, flushometer valves, tub fillers, shower valves, service saddles, or water distribution main gate valves that are 2 inches in diameter or larger are excluded from the new lead-free law.

Who does the New Regulations apply to?

If you use or introduce into commerce any pipe, valves, plumbing fittings or fixtures, solder, or flux intended to convey or dispense water for human consumption, your products must comply with the law. Additionally, if you introduce into commerce solder or flux, your products must comply with the law.

If I am a homeowner, how do I know my water system is lead-free?

Many manufacturers have already complied with the January 4th, 2014 implementation date of the federal "Reduction of Lead in Drinking Water Act." Even without federal certification requirements regarding the lead content of plumbing products, California's mandate for third-party certification will be followed by most manufacturers seeking a single approval

path that covers both federal and state requirements. For that reason, it is important to use and install only clearly marked low-lead products.

If you are a homeowner and are concerned about potential lead exposure from your private water system, have your water tested by a state certified water testing laboratory in your area.

Is there a difference between low-lead and no-lead brass?

No. There are several terms flying around to refer to the low-lead service brass products – no lead, lead free, low lead, and others. They all refer to the same products: service brass with 0.25 percent or less lead on wetter surfaces.

How are the new alloys different?

Functionally, there is almost no difference. For water utilities and contractors working with the material, it will handle just like traditional service brass. The difference is in the manufacturing. Lead has traditionally been used to fill gaps, seal the surface and create a smooth pipe interior that doesn't have gaps or pits where debris can settle and erode the metal.

Instead of lead, manufacturers will have to use different and more expensive materials and take more care in the manufacturing process. That means the cost of the new low-lead brass will be 25 to 40 percent higher than traditional brass pipe fittings and meters.

What are the biggest concerns for developers, municipalities and water districts?

There are two big concerns that should inspire anyone responsible for laying water infrastructure to act soon. If you have inventory of traditional services brass, now is the time to find a place to use it.

The second concern is cost. If you don't have an inventory of traditional brass but you have upcoming projects, this might be the ideal time to start them. Order traditional brass pipe fittings and meters from suppliers who are offering their traditional service brass at steep discounts ahead of the new law. After the law goes into effect, service brass costs will skyrocket and significantly increase your costs.

Lead-free Alternatives

There are several materials that utilities should consider when selecting a lead-free meter alternative. Various options include epoxy coated ductile and cast iron, stainless steel, low lead bronze and composite.

When choosing a lead-free alternative material, utilities must consider traditional meter requirements such as strong flow capability and durability. However, the difference between lead-free and zero lead meters should also be considered. Some "lead-free" meters contain as much as 0.25 percent lead.

While a 0.25 percentage of lead in meters allows utilities to meet current regulations, implementing these "lead-free" meters could put utilities at risk for the cost of another meter change out should future regulations require complete lead elimination from water meters. Most water meters are expected to last more than 20 years, meaning that the next amendment to SDWA could come before the meter fleet must be replaced.

This could be potentially devastating for utility companies still using older systems should completely lead-free meters become mandated.

Composite Meters

Composite meters are one example of a zero lead alternative that is not susceptible to future no-lead regulations. This meter material is also gaining popularity due to its strength and cost stability. Composite meters do not depend on metal pricing fluctuations and, more importantly, have zero lead as opposed to low lead or even bronze meters.

Made of materials that have already proven their strength and durability in the automotive and valve industries, composite meters boast longevity and resistance to corrosion from aggressive water and from the chlorinated chemicals used to make water drinkable. Composite meters are also equipped to withstand the pressure required to maintain a water system.

Composite meters are constructed using a blend of plastic and fiberglass. When compared to bronze water meter products, composites are lighter and require less time and energy to manufacture, ship and install. Composite meters attached with composite threads have been found to eliminate the “friction feeling” typically experienced with metal threads and metal couplings, facilitating easier installation.

Through comprehensive testing, composite meters have demonstrated a burst pressure that is significantly greater than bronze and an equal longevity. Composite technology today allows for better, more environmentally friendly composite products that will last up to 25 years in residential applications. Manufacturers have a wide range of “lead-free” or zero lead products on the market and it is critical that utilities consider all of their options when selecting a new fleet of meters.

Most importantly, everyone deserves access to safe, clean water. It is essential that manufacturers continually develop and deliver products that meet the highest standards for safety, quality, reliability and accuracy to ensure availability to, and conservation of, this most precious resource.

Lead in Drinking Water

Lead is unlikely to be present in source water unless a specific source of contamination exists. However, lead has long been used in the plumbing materials and solder that are in contact with drinking water as it is transported from its source into homes. Lead leaches into tap water through the corrosion of plumbing materials that contain lead.

The greater the concentration of lead in drinking water and the greater amount of lead-contaminated drinking water consumed, the greater the exposure to lead. In children, lead in drinking water has been associated both with BLLs $\geq 10 \mu\text{g/dL}$ as well as levels that are higher than the U.S. GM level for children ($1.4 \mu\text{g/dL}$) but are $< 10 \mu\text{g/dL}$.

History of Studies on Lead in Water

In 1793, the Duke of Württemberg, Germany, warned against the use of lead in drinking water pipes, and in 1878, lead pipes were outlawed in the area as a result of concerns about the adverse health effects of lead in water. In the United States, the adverse health consequences of lead-contaminated water were recognized as early as 1845. A survey conducted in 1924 in the United States indicated that lead service lines were more prevalent in New England, the Midwest, Montana, New York, Oklahoma, and Texas.

A nationwide survey conducted in 1990 indicated that 3.3 million lead service lines were in use, and the areas where they were most likely to be used were, again, the Midwestern and northeastern regions of the United States. This survey also estimated that approximately 61,000 lead service lines had been removed through voluntary programs during the previous 10 years.

Research on exposure to lead in water increased as concern about the topic increased, and efforts were made to establish a level of lead in water that, at the time of the studies, was considered acceptable. A 1972 study in Edinburgh, Scotland, obtained 949 first-flush water samples (i.e., samples of water from the tap that have been standing in the plumbing pipes for at least 6 hours) matched with 949 BLLs, as well as 205 running water samples matched to 205 BLLs. No dose-response relationship could be determined when comparing BLLs with four levels of lead in both first-flush water and in running water ($<0.24 \mu\text{mol/L}$; $0.24\text{--}0.47 \mu\text{mol/L}$; $0.48\text{--}1.43 \mu\text{mol/L}$; and $\geq 1.44 \mu\text{mol/L}$).

The study concluded that the findings challenged whether it was necessary to lower the water lead concentration to <100 ppb, which at that time was the acceptable concentration established by the World Health Organization. However, the study also reported that low levels of environmental lead exposure could have adverse health effects; therefore, knowing the degree of lead exposure from household water relative to other sources is important. Another study, in 1976, of 129 randomly selected homes in Caernarvonshire, England, reported a similar finding, describing the relationship between blood and water lead as slight.

Monitoring and Reporting

To ensure that drinking water supplied by **all** public water supply systems as defined by the EPA meet Federal and State requirements, water system operators are required to collect samples regularly and have the water tested. The regulations specify minimum sampling frequencies, sampling locations, testing procedures, methods of keeping records, and frequency of reporting to the State. The regulations also mandate special reporting procedures to be followed if a contaminant exceeds an MCL.

All systems must provide periodic monitoring for microbiological contaminants and some chemical contaminants. The frequency of sampling and the chemicals that must be tested for depend on the physical size of the water system, the water source, and the history of analyses. General sampling procedures are covered in more detail under the topic of Public Health Considerations to follow.

State policies vary on providing laboratory services. Some States have laboratory facilities available to perform all required analyses or, in some cases, a certain number of the required analyses for a system. In most States, there is a charge for all or some of the

laboratory services. Sample analyses that are required and cannot be performed by a State laboratory must be taken or sent to a State-certified private laboratory.

If the analysis of a sample exceeds an MCL, resampling is required, and the State should be contacted immediately for special instructions. There is always the possibility that such a sample was caused by a sampling or laboratory error, but it must be handled as though it actually was caused by contamination of the water supply.

The results of all water analyses must be periodically sent to the State of origin. Failure to have the required analysis performed or to report the results to the State usually will result in the water system being required to provide PN. States typically have special forms for submitting data, and specify a number of days following the end of the monitoring period by which the form is due.

General Disinfection Requirements

Disinfection is absolutely required for all water systems using surface water sources. Various chemicals other than chlorine can be used for treatment of surface water, but as the water enters the distribution system, it must carry a continuous chlorine residual that will be retained throughout the distribution system. Water samples from points on the distribution system must be analyzed periodically to make sure an adequate chlorine residual is being maintained.

In spite of the fact that use of chlorine has almost completely eliminated occurrences of waterborne diseases in the United States, there is no concern for byproducts formed when chlorine reacts with naturally occurring substances in raw water (such as decaying vegetation containing humic and fulvic acids). The first group of byproduct chemicals identified was tri-halo-methane (THM), a group of organic chemicals that are known carcinogens (cancer-forming) to some animals, so they are assumed also to be carcinogenic to humans. Other byproducts of disinfection have been identified that may be harmful, and there also is concern now that disinfectants themselves may cause some adverse health reactions.

Consumer Confidence Reports

One of the very significant provisions of the 1996 SDWA amendments is the consumer confidence report (CCR) requirement. The purpose of the CCR is to provide all water customers with basic facts regarding their drinking water so that individuals can make decisions about water consumption based on their personal health. This directive has been likened to the requirement that packaged food companies disclose what is in their food product.

The reports must be prepared yearly by every community water supply system. Water systems serving more than 10,000 people must mail the report to customers. Small systems must notify customers as directed by the State primacy agency. Beginning in the year 2000, reports were to be delivered by July 1 of the calendar year.

A water system that only distributes purchased water (i.e., a satellite system) must prepare the report for their consumers. Information on the source water and chemical analyses must be furnished to the satellite system by the system selling the water (parent company).

Some States are preparing much of the information for their water systems, but the system operator still must add local information. Templates for preparing a report also are available from the American Water Works Association (AWWA) and the National Rural Water Association (NRWA).

Water system operators should keep in mind that CCRs provide an opportunity to educate consumers about the sources and quality of their drinking water. Educated consumers are more likely to help protect drinking water sources and be more understanding of the need to upgrade the water system to make their drinking water safe.

Distribution System Water Quality Problems

Turbidity

Turbidity is caused by particles suspended in water. These particles scatter or reflect light rays, making the water appear cloudy. Turbidity is expressed in nephelometric turbidity units (ntu) and a reading in excess of 5 ntu is generally noticeable to water system customers.

Besides the appearance being unpleasant to customers, turbidity in water is significant from a public health standpoint because suspended particles could shelter micro-organisms from the disinfectant and allow them to still be viable when they reach the customer.

EPA regulations direct that, for most water systems, the turbidity of water entering the distribution system must be equal or less than 0.5 ntu in at least 95 percent of the measurements taken each month. At no time may the turbidity exceed 5 ntu.

Turbidity changes in the distribution system can indicate developing problems. Increases in turbidity may be caused by changes in velocity or inadequate flushing following main replacement.

Hardness

Hardness is a measure of the concentration of calcium and magnesium in water. Water hardness usually comes from water contacting rock formations, such as water from wells in limestone formations. Soft ground water may occur where topsoil is thin and limestone formations are sparse or absent. Most surface water is of medium hardness.

Hard and soft water are both satisfactory for human consumption, but customers may object to very hard water because of the scale it forms in plumbing fixtures and on cooking utensils. Hardness is also a problem for some industrial and commercial users because of scale buildup in boilers and other equipment.

Water generally is considered most satisfactory for household use when the hardness is between 75 and 100 mg/L as calcium carbonate (CaCO₃). Water with 300 mg/L of hardness usually is considered **hard**. Very soft water of 30 mg/L or less is found in some section of the United States. Soft water usually is quite corrosive, and may have to be treated to reduce the corrosivity.



Iron

Iron occurs naturally in rocks and soils and is one of the most abundant elements. It occurs in two forms. Ferrous iron (Fe²⁺) is in a dissolved state, and water containing ferrous iron is colorless. Ferric iron (Fe³⁺) has been oxidized, and water containing it is rust-colored. Water from some well sources contains significant levels of dissolved iron, which is colorless, but rapidly turns brown as air reaches the water and oxidizes the iron.

There are no known harmful effects to humans from drinking water containing iron, but NSDWR suggest a limit of 0.5 mg/L. At high levels, the staining of plumbing fixtures and clothing becomes objectionable. Iron also provides nutrient source for some bacteria that grow in distribution systems and wells. Iron bacteria, such as *Gallionella*, cause red water, tastes and odors, clogged pipes, and pump failure.

Whenever tests on water samples show increased iron concentrations between the point where water enters the distribution system and the consumer's tap, either corrosion, iron bacteria, or both are probably taking place. If the problem is caused by bacteria, flushing mains, shock chlorination, and carrying increased residual chlorine are alternatives to consider.

Manganese

Manganese in ground water creates problems similar to iron. It does not usually discolor the water, but will stain washed clothes and plumbing fixtures black; this is very unpopular with customers. Consumption of manganese has no known harmful effects on humans, but the NSDWR recommend a concentration not to exceed 0.05 mg/L to avoid customer complaints.

Water Quality Safeguards

The **critical** safeguard for water distribution system operations are

- continuous positive pressure in the mains; 20 pounds per square inch (psi) minimum residual pressure is recommended;
- maintenance of chlorine residual;
- cross-connection control; and
- frequent testing.

Continuous positive pressure as recommended above is absolutely necessary to prevent back siphonage and the entry of contaminants into the water system. This can be achieved primarily by maintaining an adequate water supply and storage capable of meeting peak water demands. If water demands are so great during peak demand periods that pressure declines in parts of the systems, either water use must be restricted or the water system must be upgraded to be capable of supplying more water.

System pressure also may be reduced during a main break because of the large amount of escaping water. The best safeguards against having serious pressure loss during a main break are to have adequate system storage and to be well-organized to shut down the leaking section of water main swiftly. The latter involves having personnel on call at all time to respond to emergencies, knowing where all the valves are, and having a valve exercise program so that valves are sure to operate when needed.

The ultimate proof of the bacteriological safety of the water in the distribution system comes through frequent sampling. Samples collected to meet State requirements should be considered a minimum.

Additional samples should be collected following construction and repair work as well as in response to customer complaints that could be the result of water system contamination. A distribution system can become contaminated from an outside source by accident or intention in the framework of the world climate today. Contamination problems need to be identified and appropriate action taken immediately after detection.

The design and evaluation of municipal water supply systems is based on both theoretical and applied hydraulics. Hydraulics is the branch of science that defines the mathematical laws of liquids at rest and in motion. This text material is confined to fundamental principles and what is generally referred to as **applied hydraulics**.

These fundamentals are essential for understanding many of the considerations involved in the design of a municipal water supply system, the periodic testing of water systems, and the proper evaluation of water systems to assess a given community's water supply with respect to providing adequate water supplies.

A municipal water supply system has the objective of providing an adequate and reliable water supply to meet the following demands:

- residential occupancy water consumption;
- commercial occupancy water consumption;
- industrial occupancy consumption;
- municipal and educational building use;
- Needed Fire Flows (NFFs) that are available from a planned location of fire hydrants throughout the municipality; and
- water for special community needs that include parks and recreation, street cleaning, decorative water fountains, sale of water to contractors through metered water from fire hydrants, etc.

The primary objective of the following material is to present the fundamental concept of hydraulics applied to municipal water systems, in order for municipal officials and fire officials to better understand the design and evaluation of public-sector water delivery systems.

Some fundamental hydraulic problems are provided to establish principles used to meet the above objective. A number of tables and charts are provided for future reference by the user of this material in actually working with a specific water supply system.

Reference

Water Supply Systems• Vol. II: Evaluation Methods October 2008 FEMA U.S. Fire Administration Harry E. Hickey, Ph.D.

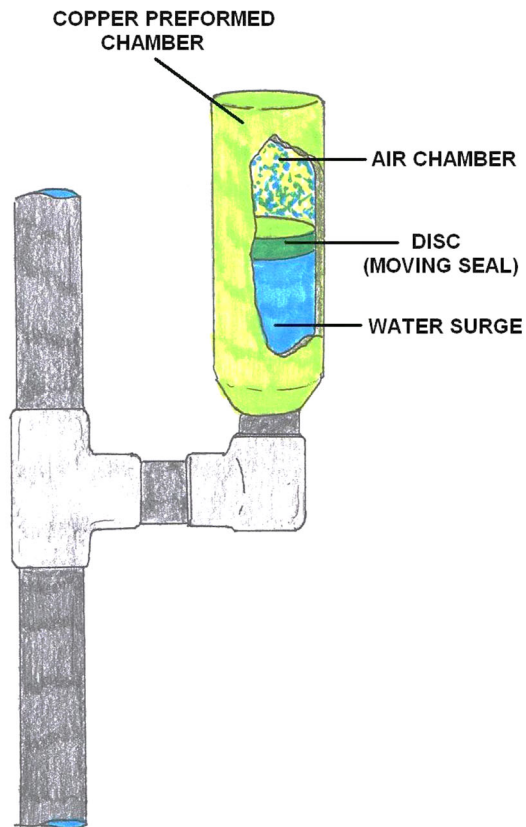

WATER HAMMER ARRESTER

A hydropneumatic device similar in principle to a shock absorber called a 'Water Hammer Arrestor' can be installed between the water pipe and the machine, to absorb the shock and stop the banging.

Water hammer has caused many water main breaks, accidents and even fatalities, but usually damage is limited to breakage of pipes or appendages. An engineer should always assess the risk of a pipeline burst. Pipelines transporting hazardous liquids or gases warrant special care in design, construction, and operation.

Types of Joints

- a) **Caulked joints.** Caulked joints for (drain, waste and vent systems only) cast iron hub-and-spigot pipe shall be firmly packed with oakum or hemp and filled with molten lead at least one-inch-deep and be firmly caulked not to extend more than 1" below the rim of the hub. Paint, varnish, or other coatings shall not be permitted on the jointing material until after a plumbing inspector has been given the opportunity to test and approve or disapprove the joint.
- b) **Threaded/Screwed Joints.** Threaded joints shall conform to American National Taper Pipe Thread, ASME B.1.20.1-1983 (General Purpose). All burrs shall be removed; pipe ends shall be reamed or filed to size of the bore and all chips shall be removed. Pipe joints compound shall be insoluble in water and non-toxic.
- c) **Wiped Joints.** Joints in lead pipe or fittings, or between lead pipe fittings and brass or copper pipe ferrules, solder nipples, or traps shall be full-wiped joints. Wiped joints shall have exposed surface on each side of the joint at least $\frac{3}{4}$ " and at least as thick as the material being joined. Wall or floor flange lead-wiped joints shall be made by using a lead ring or flange placed behind the joints at the wall or floor. Joints between lead pipe and cast iron, steel or wrought iron shall be made by means of a caulking ferrule, soldering nipple, or bushing. Note: Lead joints and lead fixtures have been banned.
- d) **Soldered Joints.** The surface to be soldered shall be cleaned bright. The joints shall be properly fluxed (lead free) and made with approved lead free solder conforming to ASTM Standard B32-1989. Joints in copper water tubing shall be made with approved cast bronze or wrought copper pressure fittings, properly soldered together. All solders or flux containing more than 0.2% lead shall bear a warning label which states that the solder or flux is not approved for private or potable water use as required by Section 4 of the federal Hazardous Substances Act (15 USC 1263). Use of this product in the making of joints or fittings in any private or public potable water system is prohibited. No part of a DWV (drain, waste and vent) system shall be joined or fitted with a solder or flux containing more than 0.2% lead. Note: Lead joints and lead fixtures have been banned.
- e) **Flared Joints.** Flared joints for plastic pipe and tubing and soft copper water tubing shall be made with approved fittings. The tubing shall be expanded with a proper flaring tool.
- f) **Hot-Poured Joints.** Hot-poured compound for clay or concrete sewer pipe shall not be water absorbent and when poured against a dry surface shall have a bond of at least 100 pounds per square inch (p.s.i.). All surfaces of the joint shall be cleaned and dried before pouring. If wet surfaces are unavoidable, a suitable primer such as oil or tar shall be applied. The compound shall not soften sufficiently to destroy effectiveness of the joint when subjected to a temperature of 160°F, and not be soluble in any of the waste carried by the drainage system. Approximately 25 percent of the joint space at the base of the socket shall be filled with jute or hemp. A pouring collar rope or other device shall be used to hold the hot compound during pouring. Each joint shall be poured in one operation until the joint is filled. Joints shall not be tested until one hour after pouring. Note: Lead joints and lead fixtures have been banned.

- g) Precast Joints. Precast collars shall be formed in both the spigot and bell of the pipe in advance of use. Prior to making joint contact, surfaces shall be cleaned. When the spigot end is inserted in the collar, it shall bind before contacting the base of the socket.
- h) Brazed Joints. Brazed joints shall be made by first cleaning the surface to be joined down to the base metal, applying flux approved for such joints and for the filler metal to be used, and making the joints by heating to a temperature sufficient to melt the approved brazing filler metal on contact. An extracted mechanical joint may be made in copper tube types K or L only for water distribution. The joint shall be made with a mechanical extraction tool and joined by brazing. To prevent the branch tube from being inserted beyond the depth of the extracted joint, depth stops shall be provided. This joint shall be for above ground use only.
- i) Cement Mortar Joints. Except for repairs, cement mortar joints are prohibited.
- j) Burned Lead (Welded). (For drain, waste and vent system only) Every burned (welded) joint shall be made in such manner that the 2 or more sections to be joined shall be uniformly fused together into one continuous piece. The thickness of the weld shall be at least as thick as the lead being joined. Note: Lead joints and lead fixtures have been banned.
- k) Bituminized Fiber Pipe Joints. Joints in bituminized fiber pipe shall be made with tapered type couplings of the same composition as the pipe. Joints between bituminized fiber pipe and metal pipe shall be made by means of an adaptor coupling caulked as required in subsection (a) of this Section.

Plastic Pipe Joints

1) Every joint in plastic piping shall be made with approved fittings by either solvent welded or fusion welded connections, compression fittings, approved insert fittings, metal clamps and screws of corrosion resistant material, or threaded joints.

2) Joints and Fittings in Plastic Pipe. Potable water piping fittings and joints shall be in accordance with the manufacturer's recommendations.

A) Polyethylene (PE) pipe shall be installed only with compression fittings, insert and clamp type fittings or thermal welded joints and fittings. All clamps shall be of corrosion resistant material. The inside diameter (I.D.) of any insert fitting shall not be less than the minimum allowable size for water service/distribution piping.

B) Polyvinyl chloride (PVC) pipe shall be installed with solvent welded or flanged joints only. The pipe shall not be threaded. Transition to metallic or other piping shall be made with the use of adaptor fittings. The fittings shall be molded from polyvinyl chloride. The primer and solvent cement used shall be in accordance with the manufacturer's recommendation for polyvinyl chloride piping.

C) Polybutylene (PB) pipe shall be installed only with insert and clamp type fittings, compression type, flanged type, or thermal welded joints and fittings. All clamps shall be of corrosion resistant material. The inside diameter (I.D.) of any insert fitting shall not be less than the minimum allowable size for water service/distribution piping.

3) Joints in Plastic Drainage. Joints in plastic drainage piping or vent piping within a building shall be solvent welded. Threaded or flanged joints may be used with adaptor fittings. The solvent cement shall be specific for the type of piping material. O-ring expansion joints are acceptable if accessible.

m) Ground Joint Connections. Ground joint connections (when accessible) may be used on the inlet or outlet side of a fixture trap or within the trap seal. Ground joint connections shall not be used in any inaccessible drainage piping.

n) No-Hub Soil Pipe Joints. Shielded joints for no-hub cast iron soil pipe shall be made with an elastomeric gasket covered by either a stainless steel shield secured by 2 or more stainless steel bands or clamps, or covered by cast iron couplings secured with stainless steel nuts and bolts. When a stainless steel shield is used, the shield and clamps shall be corrosion resistant and homogeneous throughout.

Compression Type Joints.

1) Compression type joints for hub and spigot cast iron soil pipe shall be made with neoprene insert gaskets in accordance with ASTM C564. The pipe shall comply with the specifications contained in ASTM A-74 with regard to hub and spigot dimensions and tolerances.

2) Compression type joints for copper water tube or brass tube shall be made with brass ferrules and ground joint connections.

- p) Grooved Type Mechanical Couplings.
- 1) Cut grooved type mechanical couplings, fittings and valves used on standard weight galvanized steel pipe, cast iron pipe or ductile iron pipe shall comply with the grooving dimensions of the AWWA specifications C606-78, limited to water distribution piping and downspout pipe above ground.
 - 2) Rolled grooved type mechanical couplings, fittings and valves used on standard weight galvanized steel pipe or type K or L copper tubing shall comply with the manufacturer's standard, limited to water distribution piping above ground. Fittings, couplings and valves shall be compatible with the pipe material. Transition adapters shall be dielectric type.
 - 3) Gaskets for use with potable water piping shall be fabricated from material that is non-toxic, durable and impervious.
- q) Copper Press Fittings. Copper press fittings for joining copper water tubing shall have an elastomeric o-ring that forms the joint. The fitting shall be made by pressing the socket joint under pressure in accordance with the manufacturer's installation requirements and NSF Standard 61.

Tightness Joints and Connections

Joints and connections shall be gas-tight and water-tight.

Special Joints

- a) Copper Tubing to Screwed Pipe Joints. Joints from copper tubing to threaded pipe shall be made by the use of a cast bronze or wrought copper adaptor fitting. The joint between copper tubing and the fitting shall be soldered or, if flared or compression, must be accessible.
- b) Welding or Brazing. Brazing or welding shall be in accordance with the provisions of Section 6 of the Code for Pressure Piping, ANSI B.3.1 and ANSI B.3.L.1.
- c) Slip Joints. In drainage and water piping, slip joints may be used on the inlet side of the trap or in the trap seal, and on the exposed fixture supply. Slip joints shall not be used in any inaccessible piping. Push-on angle stop valves are permitted, provided they meet the following specifications: they are installed by being pushed onto copper or CPVC; they are mechanically secured by metal tabs which grip the piping; they are sealed with o-rings; and they are capable of withstanding a water pressure of 150 pounds per square inch and a temperature of 210 degrees Fahrenheit.
- d) Expansion Joints. Expansion joints must be accessible and may be used where necessary to provide for expansion or contraction of the piping. The expansion joint material shall conform to the type piping on which it is installed.
- e) Compression type couplings shall not be used in unexposed water piping except for water services, water meter yokes and stop box connections.
- f) Grooved Type Mechanical Couplings. Grooved type mechanical couplings, in accordance with Section 890.320(p), may be used in potable water and roof drain piping. Such couplings shall not be used in waste, soil or vent piping.
- g) Plastic Pipe to Non-Plastic Pipe Joints. Joints between plastic pipe and non-plastic pipe shall be made only by one of the following methods:
 - 1) Pressure piping.
 - A) Approved insert fittings.
 - B) Threaded adaptors.
 - C) Flanges.
 - D) Flared fittings.
 - 2) Non-pressure piping - Drain Waste Vent (DWV)
 - A) Caulked lead joints with caulked adaptors.
 - B) No-hub soil pipe shielded couplings with approved adaptor having a raised bead.
 - C) Compression type joints for hub and spigot cast iron pipe.
 - D) Threaded adaptors.

Use of Joints

- a) Clay Sewer Pipe. Joints in vitrified clay pipe or between such pipe and metal pipe shall be made with a neoprene gasket and stainless steel bands.
- b) Concrete Sewer Pipe. Joints in concrete sewer pipe or between such pipe and metal pipe shall be made with a neoprene gasket and stainless steel bands.
- c) Cast Iron Pipe. A joint in cast iron water supply pipe shall be made in accordance with Section 890.320(a) and (b) or shall be a mechanical joint.
- d) Screw Pipe to Cast Iron. Joints between wrought iron, steel, brass, or copper pipe, and cast iron pipe shall be either caulked or threaded joints which are made as provided in Section 890.320 (a) or (b) and shall be made with proper adaptor fittings.
- e) Lead to Cast Iron, Wrought Iron or Steel. Joints between lead and cast iron, wrought iron, or steel pipe shall be made by means of wiped joints to a caulking ferrule, soldering nipple, or brushing.
- f) Copper Water Tube. Joints in copper tubing shall be made with cast bronze or wrought copper pressure fittings, properly soldered or brazed, or by means of compression or flared joints. Flared joints and compression fittings shall not be installed underground except for water services, water meter yokes and stop box connections.
- g) Plastic Pipe. Joints between plastic pipe and non-plastic material shall be made only with an appropriate type adaptor.
 - 1) Plastic-Commingling. There shall be no commingling of plastic materials within the same plumbing system except through the use of proper adaptors.
 - 2) Plastic Pipe. Plastic pipe shall not be installed in any tunnel or chase that contains uninsulated hot water, hot air or steam piping which causes the ambient air temperature in the tunnel or chase to exceed 180°F.
- h) Building Sewer Connections. An elastomeric coupling seal conforming to ASTM C 425 (1988), ASTM C 443 (1985), ASTM C 564 (1988), ASTM D 4161 (1986), ASTM F 477 (1985), or ASTM D 3139 (1989), ASTM D 3212 (1989), or ASTM D 412 (1980) tests may be used to adapt any 2 building sewer pipes for different materials or size changes. The flexible couplings shall be attached to the pipe with stainless steel clamps or bolts. The manufacturer's recommended method of installation shall be followed.

Unions

Unions may be used in the drainage and venting system when accessibly located above ground. Unions shall be installed in a water supply system within 5 feet of regulating equipment, water heaters, water conditioning tanks, water conditioning equipment, pumps, and similar equipment which may require service by removal or replacement. Where small equipment may be unscrewed, only one union shall be required.

a) Drainage System. Unions may be used in the trap seal and on the inlet and outlet side of the trap. Unions shall have metal to metal seats except that plastic unions may have plastic to plastic seats.

b) Water Supply System. Unions in the water supply system shall be metal to metal with ground seats, except that plastic to metal unions may utilize durable, non-toxic, impervious gaskets. Unions between copper pipe/tubing and dissimilar metals shall either be made with a brass converter fitting or be a dielectric type union.

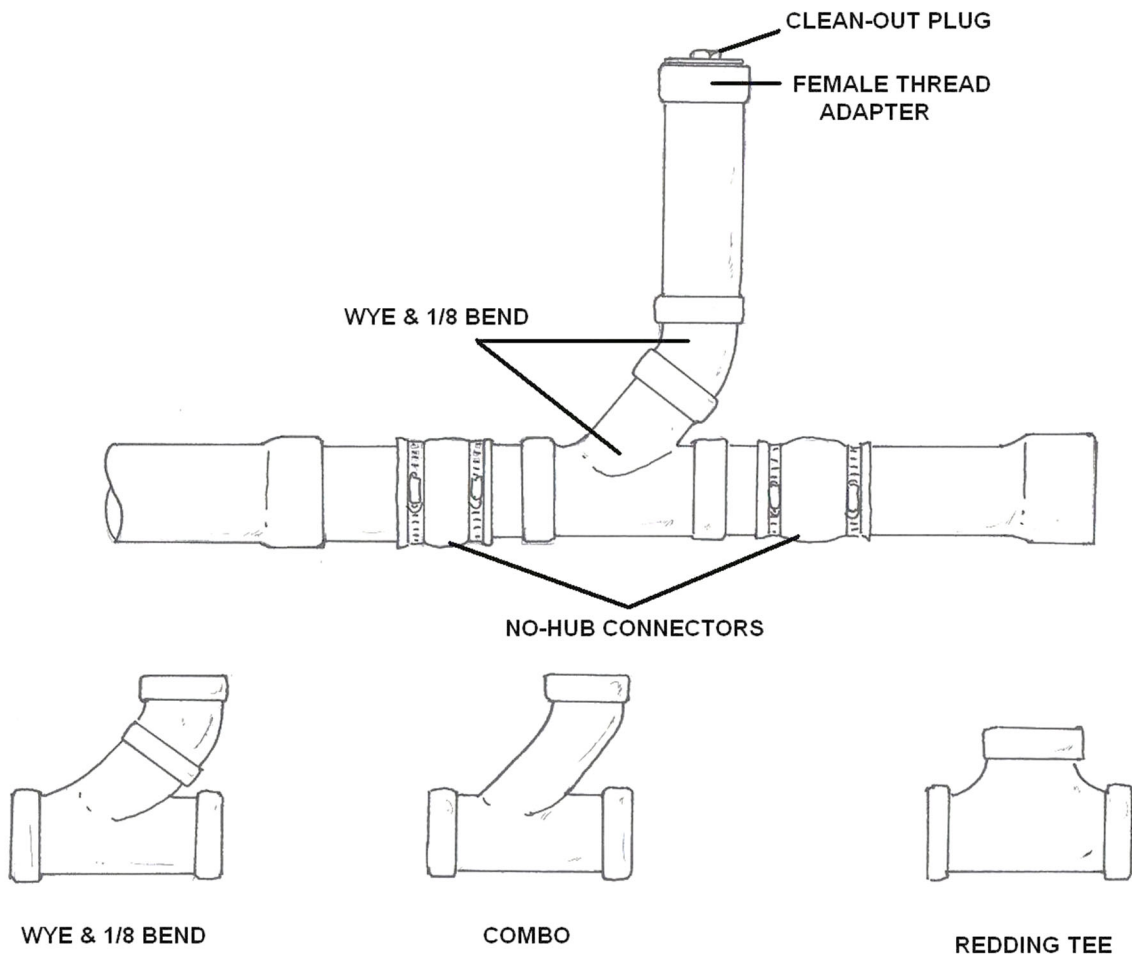

Glossary

A

Absolute Pressure: The pressure above zone absolute, i.e. the sum of atmospheric and gauge pressure. In vacuum related work it is usually expressed in millimeters of mercury. (mmHg).

Aerodynamics: The study of the flow of gases. The Ideal Gas Law - For a perfect or ideal gas the change in density is directly related to the change in temperature and pressure as expressed in the Ideal Gas Law.

Aeronautics: The mathematics and mechanics of flying objects, in particular airplanes.

Air Break: A physical separation which may be a low inlet into the indirect waste receptor from the fixture, or device that is indirectly connected. You will most likely find an air break on waste fixtures or on non-potable lines. You should never allow an air break on an ice machine.

Air Gap Separation: A physical separation space that is present between the discharge vessel and the receiving vessel, for an example, a kitchen faucet.

Altitude-Control Valve: If an overflow occurs on a storage tank, the operator should first check the altitude-control valve. Altitude-Control Valve is designed to, 1. Prevent overflows from the storage tank or reservoir, or 2. Maintain a constant water level as long as water pressure in the distribution system is adequate.

Angular Motion Formulas: Angular velocity can be expressed as (angular velocity = constant):

$$\omega = \theta / t \text{ (2a)}$$

where

ω = angular velocity (rad/s)

θ = angular displacement (rad)

t = time (s)

Angular velocity can be expressed as (angular acceleration = constant):

$$\omega = \omega_o + \alpha t \text{ (2b)}$$

where

ω_o = angular velocity at time zero (rad/s)

α = angular acceleration (rad/s²)

Angular displacement can be expressed as (angular acceleration = constant):

$$\theta = \omega_o t + 1/2 \alpha t^2 \text{ (2c)}$$

Combining 2a and 2c:

$$\omega = (\omega_o^2 + 2 \alpha \theta)^{1/2}$$

Angular acceleration can be expressed as:

$$\alpha = d\omega / dt = d^2\theta / dt^2 \text{ (2d)}$$

where

$d\theta$ = change of angular displacement (rad)
 dt = change in time (s)

Atmospheric Pressure: Pressure exerted by the atmosphere at any specific location. (Sea level pressure is approximately 14.7 pounds per square inch absolute, 1 bar = 14.5psi.)

B

Backflow Prevention: To stop or prevent the occurrence of, the unnatural act of reversing the normal direction of the flow of liquid, gases, or solid substances back in to the public potable (drinking) water supply. See Cross-connection control.

Backflow: To reverse the natural and normal directional flow of a liquid, gases, or solid substances back in to the public potable (drinking) water supply. This is normally an undesirable effect.

Backsiphonage: A liquid substance that is carried over a higher point. It is the method by which the liquid substance may be forced by excess pressure over or into a higher point. Is a condition in which the pressure in the distribution system is less than atmospheric pressure. In other words, something is "sucked" into the system because the main is under a vacuum.

Bernoulli's Equation: Describes the behavior of moving fluids along a streamline. The Bernoulli Equation can be considered to be a statement of the conservation of energy principle appropriate for flowing fluids. The qualitative behavior that is usually labeled with the term "**Bernoulli effect**" is the lowering of fluid pressure in regions where the flow velocity is increased. This lowering of pressure in a constriction of a flow path may seem counterintuitive, but seems less so when you consider pressure to be energy density. In the high velocity flow through the constriction, kinetic energy must increase at the expense of pressure energy.

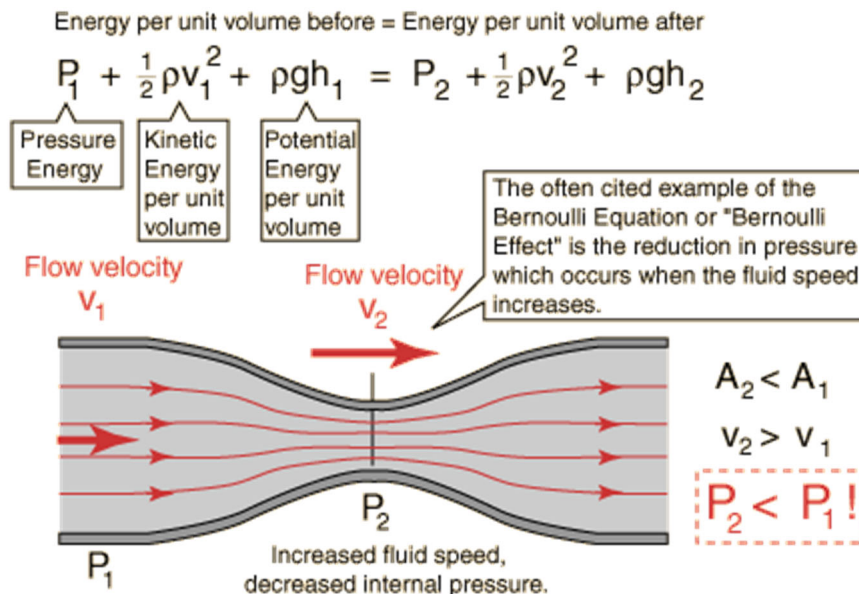

A special form of the Euler's equation derived along a fluid flow streamline is often called the **Bernoulli Equation**.

$$\frac{\partial}{\partial s} \left(\frac{v^2}{2} + \frac{p}{\rho} + g \cdot h \right) = 0 \quad (1)$$

where

v = flow speed

p = pressure

ρ = density

g = gravity

h = height

$$\frac{v^2}{2} + \frac{p}{\rho} + g \cdot h = \text{Constant} \quad (2)$$

$$\frac{v^2}{2 \cdot g} + \frac{p}{\gamma} + h = \text{Constant} \quad (3)$$

where

$$\gamma = \rho \cdot g$$

$$\frac{\rho \cdot v^2}{2} + p = \text{Constant} \quad (4)$$

$$\frac{\rho \cdot v^2}{2} = p_d \quad (5)$$

$$\frac{\rho \cdot v_1^2}{2} + p_1 = \frac{\rho \cdot v_2^2}{2} + p_2 = \text{Constant} \quad (6)$$

www.engineeringtoolbox.com

For steady state incompressible flow the Euler equation becomes (1). If we integrate (1) along the streamline it becomes (2). (2) can further be modified to (3) by dividing by gravity.

Head of Flow: Equation (3) is often referred to as the **head** because all elements have the unit of length.

Bernoulli's Equation Continued:

Dynamic Pressure

(2) and (3) are two forms of the Bernoulli Equation for steady state incompressible flow. If we assume that the gravitational body force is negligible, (3) can be written as (4). Both elements in the equation have the unit of pressure and it's common to refer the flow velocity component as the **dynamic pressure** of the fluid flow (5).

Since energy is conserved along the streamline, (4) can be expressed as (6). Using the equation we see that increasing the velocity of the flow will reduce the pressure, decreasing the velocity will increase the pressure. This phenomena can be observed in a **venturi meter** where the pressure is reduced in the constriction area and regained after. It can also be observed in a **pitot tube** where the **stagnation** pressure is measured. The stagnation pressure is where the velocity component is zero.

Bernoulli's Equation Continued:

Pressurized Tank

If the tanks are pressurized so that product of gravity and height ($g h$) is much less than the pressure difference divided by the density, (e4) can be transformed to (e6).

The velocity out from the tanks depends mostly on the pressure difference.

Example - outlet velocity from a pressurized tank

The outlet velocity of a pressurized tank where

$$p_1 = 0.2 \text{ MN/m}^2, p_2 = 0.1 \text{ MN/m}^2, A_2/A_1 = 0.01, h = 10 \text{ m}$$

can be calculated as

$$V_2 = [(2/(1-(0.01)^2) ((0.2 - 0.1) \times 10^6 / 1 \times 10^3 + 9.81 \times 10)]^{1/2} = \underline{19.9 \text{ m/s}}$$

Coefficient of Discharge - Friction Coefficient

Due to friction the real velocity will be somewhat lower than this theoretical example. If we introduce a **friction coefficient** c (coefficient of discharge), (e5) can be expressed as (e5b). The coefficient of discharge can be determined experimentally. For a sharp edged opening it may be as low as 0.6. For smooth orifices it may be between 0.95 and 1.

Bingham Plastic Fluids: **Bingham Plastic Fluids** have a yield value which must be exceeded before it will start to flow like a fluid. From that point the viscosity will decrease with increase of agitation. Toothpaste, mayonnaise and tomato catsup are examples of such products.

Boundary Layer: The layer of fluid in the immediate vicinity of a bounding surface.

Bulk Modulus and Fluid Elasticity: An introduction to and a definition of the Bulk Modulus Elasticity commonly used to characterize the compressibility of fluids.

The Bulk Modulus Elasticity can be expressed as

$$E = - dp / (dV / V) \quad (1)$$

where

E = bulk modulus elasticity

dp = differential change in pressure on the object

dV = differential change in volume of the object

V = initial volume of the object

The Bulk Modulus Elasticity can be alternatively expressed as

$$E = - dp / (d\rho / \rho) \quad (2)$$

where

$d\rho$ = differential change in density of the object

ρ = initial density of the object

An increase in the pressure will decrease the volume (1). A decrease in the volume will increase the density (2).

- The SI unit of the bulk modulus elasticity is N/m^2 (Pa)

- The imperial (BG) unit is lb_f/in^2 (psi)
- $1 \text{ lb}_f/\text{in}^2$ (psi) = $6.894 \times 10^3 \text{ N/m}^2$ (Pa)

A large Bulk Modulus indicates a relatively incompressible fluid.

Bulk Modulus for some common fluids can be found in the table below:

Bulk Modulus - E	Imperial Units - BG (psi, lb_f/in^2) $\times 10^5$	SI Units (Pa, N/m^2) $\times 10^9$
Carbon Tetrachloride	1.91	1.31
Ethyl Alcohol	1.54	1.06
Gasoline	1.9	1.3
Glycerin	6.56	4.52
Mercury	4.14	2.85
SAE 30 Oil	2.2	1.5
Seawater	3.39	2.35
Water	3.12	2.15

C

Capillarity: (or capillary action) The ability of a narrow tube to draw a liquid upwards against the force of gravity.

The height of liquid in a tube due to capillarity can be expressed as

$$h = 2 \sigma \cos\theta / (\rho g r) \quad (1)$$

where

h = height of liquid (ft, m)

σ = surface tension (lb/ft, N/m)

θ = contact angle

ρ = density of liquid (lb/ft³, kg/m³)

g = acceleration due to gravity (32.174 ft/s², 9.81 m/s²)

r = radius of tube (ft, m)

Cauchy Number: A dimensionless value useful for analyzing fluid flow dynamics problems where compressibility is a significant factor.

The Cauchy Number is the ratio between inertial and the compressibility force in a flow and can be expressed as

$$C = \rho v^2 / E \quad (1)$$

where

ρ = density (kg/m³)

v = flow velocity (m/s)

E = bulk modulus elasticity (N/m²)

The bulk modulus elasticity has the dimension pressure and is commonly used to characterize the compressibility of a fluid.

The Cauchy Number is the square root of the Mach Number

$$M^2 = Ca \quad (3)$$

where

C = Mach Number

Cavitation: Under the wrong condition, cavitation will reduce the components life time dramatically. Cavitation may occur when the local static pressure in a fluid reach a level below the vapor pressure of the liquid at the actual temperature. According to the Bernoulli Equation this may happen when the fluid accelerates in a control valve or around a pump impeller. The vaporization itself does not cause the damage - the damage happens when the vapor almost immediately collapses after evaporation when the velocity is decreased and pressure increased.

Cavitation means that cavities are forming in the liquid that we are pumping. When these cavities form at the suction of the pump several things happen all at once: We experience a loss in capacity. We can no longer build the same head (pressure). The efficiency drops. The cavities or bubbles will collapse when they pass into the higher regions of pressure causing noise, vibration, and damage to many of the components. The cavities form for five basic reasons and it is common practice to lump all of them into the general classification of cavitation.

This is an error because we will learn that to correct each of these conditions we must understand why they occur and how to fix them. Here they are in no particular order: Vaporization, Air ingestion, Internal recirculation, Flow turbulence and finally the Vane Passing Syndrome.

Avoiding Cavitation

Cavitation can in general be avoided by:

- increasing the distance between the actual local static pressure in the fluid - and the vapor pressure of the fluid at the actual temperature

This can be done by:

- reengineering components initiating high speed velocities and low static pressures
- increasing the total or local static pressure in the system
- reducing the temperature of the fluid

Reengineering of Components Initiating High Speed Velocity and Low Static Pressure

Cavitation and damage can be avoided by using special components designed for the actual rough conditions.

- Conditions such as huge pressure drops can - with limitations - be handled by Multi Stage Control Valves
- Difficult pumping conditions - with fluid temperatures close to the vaporization temperature - can be handled with a special pump - working after another principle than the centrifugal pump.

Cavitation Continued: Increasing the Total or Local Pressure in the System

By increasing the total or local pressure in the system, the distance between the static pressure and the vaporization pressure is increased and vaporization and cavitation may be avoided. The ratio between static pressure and the vaporization pressure, an indication of the possibility of vaporization, is often expressed by the Cavitation Number. Unfortunately it may not always be possible to increase the total static pressure due to system classifications or other limitations. Local static pressure in the component may then be increased by lowering the component in the system. Control valves and pumps should in general be positioned in the lowest part of the system to maximize the static head. This is common for boiler feeding pumps receiving hot condensate (water close to 100 °C) from a condensate receiver.

Cavitation Continued: Reducing the Temperature of the Fluid

The vaporization pressure is highly dependent on the fluid temperature. Water, our most common fluid, is an example:

Temperature (°C)	Vapor Pressure (kN/m ²)
0	0.6
5	0.9
10	1.2
15	1.7
20	2.3
25	3.2
30	4.3
35	5.6
40	7.7
45	9.6
50	12.5
55	15.7
60	20
65	25
70	32.1
75	38.6
80	47.5
85	57.8
90	70
95	84.5
100	101.33

As we can see - the possibility of evaporation and cavitation increases dramatically with the water temperature.

Cavitation can be avoided by locating the components in the coldest part of the system. For example, it is common to locate the pumps in heating systems at the "cold" return lines. The situation is the same for control valves. Where it is possible they should be located on the cold side of heat exchangers.

Cavitations Number: A "special edition" of the dimensionless Euler Number.

The Cavitations Number is useful for analyzing fluid flow dynamics problems where cavitations may occur. The Cavitations Number can be expressed as

$$Ca = (p_r - p_v) / 1/2 \rho v^2 \quad (1)$$

where

Ca = Cavitations number

p_r = reference pressure

(Pa)

p_v = vapor pressure of the fluid (Pa)

ρ = density of the fluid

(kg/m³)

v = velocity of fluid (m/s)

Centrifugal Pump: A pump consisting of an impeller fixed on a rotating shaft and enclosed in a casing, having an inlet and a discharge connection. The rotating impeller creates pressure in the liquid by the velocity derived from centrifugal force.

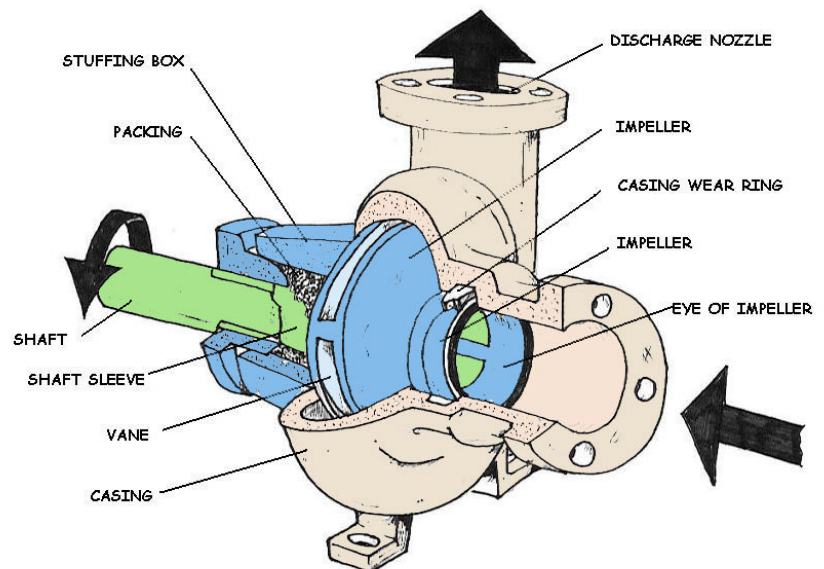

Chezy Formula: Conduits flow and mean velocity. The Chezy formula can be used to calculate mean flow velocity in conduits and is expressed as

$$v = c (R S)^{1/2} \quad (1)$$

where

v = mean velocity (m/s, ft/s)

c = the Chezy roughness and conduit coefficient

R = hydraulic radius of the conduit (m, ft)

S = slope of the conduit (m/m, ft/ft)

In general the Chezy coefficient - c - is a function of the flow Reynolds Number - Re - and the relative roughness - ϵ/R - of the channel.

ϵ is the characteristic height of the roughness elements on the channel boundary.

Coanda Effect: The tendency of a stream of fluid to stay attached to a convex surface, rather than follow a straight line in its original direction.

Colebrook Equation: The friction coefficients used to calculate pressure loss (or major loss) in ducts, tubes and pipes can be calculated with the Colebrook equation.

$$1 / \lambda^{1/2} = -2 \log ((2.51 / (Re \lambda^{1/2})) + (k / d_h) / 3.72) \quad (1)$$

where

λ = D'Arcy-Weisbach friction coefficient

Re = Reynolds Number

k = roughness of duct, pipe or tube surface (m, ft)

d_h = hydraulic diameter (m, ft)

The Colebrook equation is only valid at turbulent flow conditions.

Note that the friction coefficient is involved on both sides of the equation and that the equation must be solved by iteration.

The Colebrook equation is generic and can be used to calculate the friction coefficients in different kinds of fluid flows - air ventilation ducts, pipes and tubes with water or oil, compressed air and much more.

Common Pressure Measuring Devices: The Strain Gauge is a common measuring device used for a variety of changes such as head. As the pressure in the system changes, the diaphragm expands which changes the length of the wire attached. This change of length of the wire changes the Resistance of the wire, which is then converted to head. Float mechanisms, diaphragm elements, bubbler tubes, and direct electronic sensors are common types of level sensors.

Compressible Flow: We know that fluids are classified as Incompressible and Compressible fluids. Incompressible fluids do not undergo significant changes in density as they flow. In general, liquids are incompressible; water being an excellent example. In contrast compressible fluids do undergo density changes.

Gases are generally compressible; air being the most common compressible fluid we can find. Compressibility of gases leads to many interesting features such as shocks, which are absent for incompressible fluids. Gas dynamics is the discipline that studies the flow of compressible fluids and forms an important branch of Fluid Mechanics. In this book we give a broad introduction to the basics of compressible fluid flow.

In a compressible flow the compressibility of the fluid must be taken into account. The Ideal Gas Law - For a perfect or ideal gas the change in density is directly related to the change in temperature and pressure as expressed in the Ideal Gas Law. Properties of **Gas Mixtures** - Special care must be taken for gas mixtures when using the ideal gas law, calculating the mass, the individual gas constant or the density. The Individual and **Universal Gas Constant** - The Individual and Universal Gas Constant is common in fluid mechanics and thermodynamics.

D

Darcy-Weisbach Equation: The **pressure loss** (or major loss) in a pipe, tube or duct can be expressed with the D'Arcy-Weisbach equation:

$$\Delta p = \lambda (l / d_h) (\rho v^2 / 2) (1)$$

where

Δp = pressure loss (Pa, N/m², lb_f/ft²)

λ = D'Arcy-Weisbach friction coefficient

l = length of duct or pipe (m, ft)

d_h = hydraulic diameter (m, ft)

ρ = density (kg/m³, lb/ft³)

Note! Be aware that there are two alternative friction coefficients present in the literature. One is 1/4 of the other and (1) must be multiplied with four to achieve the correct result. This is important to verify when selecting friction coefficients from Moody diagrams.

Density: Is a physical property of matter, as each element and compound has a unique density associated with it.

Density defined in a qualitative manner as the measure of the relative "heaviness" of objects with a constant volume. For example: A rock is obviously more dense than a crumpled piece of paper of the same size. A Styrofoam cup is less dense than a ceramic cup. Density may also refer to how closely "packed" or "crowded" the material appears to be - again refer to the Styrofoam vs. ceramic cup. Take a look at the two boxes below.

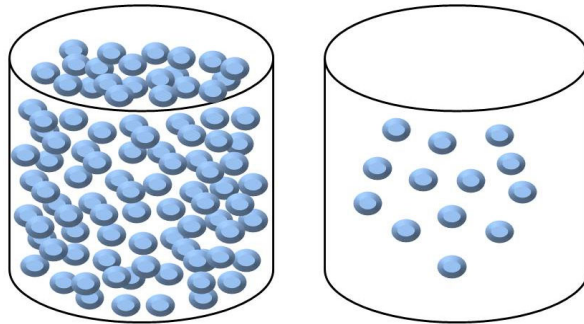

Each box has the same volume. ***If each ball has the same mass, which box would weigh more? Why?***

The box that has more balls has more mass per unit of volume. This property of matter is called density. The density of a material helps to distinguish it from other materials. Since mass is usually expressed in grams and volume in cubic centimeters, density is expressed in grams/cubic centimeter. We can calculate density using the formula:

$$\text{Density} = \text{Mass} / \text{Volume}$$

The density can be expressed as

$$\rho = m / V = 1 / v_g (1)$$

where
 ρ = density (kg/m³)
 m = mass (kg)
 V = volume (m³)
 v_g = specific volume (m³/kg)

The SI units for density are kg/m³. The imperial (BG) units are lb/ft³ (slugs/ft³). While people often use pounds per cubic foot as a measure of density in the U.S., pounds are really a measure of force, not mass. Slugs are the correct measure of mass. You can multiply slugs by 32.2 for a rough value in pounds. The higher the density, the tighter the particles are packed inside the substance. Density is a physical property constant at a given temperature and density can help to identify a substance.

Example - Use the Density to Identify the Material:

An unknown liquid substance has a mass of 18.5 g and occupies a volume of 23.4 ml. (milliliter).

The density can be calculated as

$$\begin{aligned} \rho &= [18.5 \text{ (g)} / 1000 \text{ (g/kg)}] / [23.4 \text{ (ml)} / 1000 \text{ (ml/l)} 1000 \text{ (l/m}^3\text{)}] \\ &= 18.5 \cdot 10^{-3} \text{ (kg)} / 23.4 \cdot 10^{-6} \text{ (m}^3\text{)} \\ &= \underline{790 \text{ kg/m}^3} \end{aligned}$$

If we look up densities of some common substances, we can find that ethyl alcohol, or ethanol, has a density of 790 kg/m³. Our unknown liquid may likely be ethyl alcohol!

Example - Use Density to Calculate the Mass of a Volume

The density of titanium is 4507 kg/m³. Calculate the mass of 0.17 m³ titanium!

$$\begin{aligned} m &= 0.17 \text{ (m}^3\text{)} 4507 \text{ (kg/m}^3\text{)} \\ &= \underline{766.2 \text{ kg}} \end{aligned}$$

Dilatant Fluids: Shear Thickening Fluids or Dilatant Fluids increase their viscosity with agitation. Some of these liquids can become almost solid within a pump or pipe line. With agitation, cream becomes butter and Candy compounds, clay slurries and similar heavily filled liquids do the same thing.

Disinfect: To kill and inhibit growth of harmful bacterial and viruses in drinking water.

Disinfection: The treatment of water to inactivate, destroy, and/or remove pathogenic bacteria, viruses, protozoa, and other parasites.

Distribution System Water Quality: Can be adversely affected by improperly constructed or poorly located blowoffs of vacuum/air relief valves. Air relief valves in the distribution system lines must be placed in locations that cannot be flooded. This is to prevent water contamination. The common customer complaint of Milky Water or Entrained Air is sometimes solved by the installation of air relief valves. The venting of air is not a major concern when checking water levels in a storage tank.

If the vent line on a ground level storage tank is closed or clogged up, a vacuum will develop in the tank may happen to the tank when the water level begins to lower.

Drag Coefficient: Used to express the drag of an object in moving fluid. Any object moving through a fluid will experience a drag - the net force in direction of flow due to the pressure and shear stress forces on the surface of the object.

The drag force can be expressed as:

$$F_d = c_d \frac{1}{2} \rho v^2 A \quad (1)$$

where

F_d = drag force (N)

c_d = drag coefficient

ρ = density of fluid

v = flow velocity

A = characteristic frontal area of the body

The drag coefficient is a function of several parameters as shape of the body, Reynolds Number for the flow, Froude number, Mach Number and Roughness of the Surface. The characteristic frontal area - A - depends on the body.

Dynamic or Absolute Viscosity: The viscosity of a fluid is an important property in the analysis of liquid behavior and fluid motion near solid boundaries. The viscosity of a fluid is its resistance to shear or flow and is a measure of the adhesive/cohesive or frictional properties of a fluid. The resistance is caused by intermolecular friction exerted when layers of fluids attempts to slide by another.

Dynamic Pressure: Dynamic pressure is the component of fluid pressure that represents a fluids kinetic energy. The dynamic pressure is a defined property of a moving flow of gas or liquid and can be expressed as

$$p_d = \frac{1}{2} \rho v^2 \quad (1)$$

where

p_d = dynamic pressure (Pa)

ρ = density of fluid (kg/m^3)

v = velocity (m/s)

Dynamic, Absolute and Kinematic Viscosity: The viscosity of a fluid is an important property in the analysis of liquid behavior and fluid motion near solid boundaries. The viscosity is the fluid resistance to shear or flow and is a measure of the adhesive/cohesive or frictional fluid property. The resistance is caused by intermolecular friction exerted when layers of fluids attempts to slide by another.

Viscosity is a measure of a fluid's resistance to flow.

The knowledge of viscosity is needed for proper design of required temperatures for storage, pumping or injection of fluids.

Common used units for viscosity are

- CentiPoises (cp) = CentiStokes (cSt) × Density
- SSU¹ = Centistokes (cSt) × 4.55
- Degree Engler¹ × 7.45 = Centistokes (cSt)
- Seconds Redwood¹ × 0.2469 = Centistokes (cSt)

¹centistokes greater than 50

There are two related measures of fluid viscosity - known as **dynamic (or absolute)** and **kinematic** viscosity.

Dynamic (absolute) Viscosity: The tangential force per unit area required to move one horizontal plane with respect to the other at unit velocity when maintained a unit distance apart by the fluid. The shearing stress between the layers of non-turbulent fluid moving in straight parallel lines can be defined for a Newtonian fluid as:

The dynamic or absolute viscosity can be expressed like

$$\tau = \mu \, dc/dy \quad (1)$$

where

τ = shearing stress

μ = dynamic viscosity

Equation (1) is known as the **Newton's Law of Friction**.

In the SI system the dynamic viscosity units are **N s/m²**, **Pa s** or **kg/m s** where

- $1 \text{ Pa s} = 1 \text{ N s/m}^2 = 1 \text{ kg/m s}$

The dynamic viscosity is also often expressed in the metric CGS (centimeter-gram-second) system as **g/cm.s**, **dyne.s/cm²** or **poise (p)** where

- $1 \text{ poise} = \text{dyne s/cm}^2 = \text{g/cm s} = 1/10 \text{ Pa s}$

For practical use the Poise is too large and its usual divided by 100 into the smaller unit called the **centiPoise (cP)** where

- $1 \text{ p} = 100 \text{ cP}$

Water at 68.4°F (20.2°C) has an absolute viscosity of one - 1 - centiPoise.

E

E. Coli, *Escherichia coli*: A bacterium commonly found in the human intestine. For water quality analyses purposes, it is considered an indicator organism. These are considered evidence of water contamination. Indicator organisms may be accompanied by pathogens, but do not necessarily cause disease themselves.

Elevation Head: The energy possessed per unit weight of a fluid because of its elevation. 1 foot of water will produce .433 pounds of pressure head.

Energy: The ability to do work. Energy can exist in one of several forms, such as heat, light, mechanical, electrical, or chemical. Energy can be transferred to different forms. It also can exist in one of two states, either potential or kinetic.

Energy and Hydraulic Grade Line: The hydraulic grade and the energy line are graphical forms of the Bernoulli equation. For steady, in viscid, incompressible flow the total energy remains constant along a stream line as expressed through the Bernoulli

Equation:

$$p + 1/2 \rho v^2 + \gamma h = \text{constant along a streamline (1)}$$

where

p = static pressure (relative to the moving fluid)

ρ = density

γ = specific weight

v = flow velocity

g = acceleration of gravity

h = elevation height

Each term of this equation has the dimension *force per unit area* - psi, lb/ft² or N/m².

The Head

By dividing each term with the specific weight - $\gamma = \rho g$ - (1) can be transformed to express the "head":

$$p / \gamma + v^2 / 2 g + h = \text{constant along a streamline} = H \text{ (2)}$$

where

H = the total head

Each term of this equation has the dimension length - ft, m.

The Total Head

(2) states that the sum of **pressure head** - p / γ -, **velocity head** - $v^2 / 2 g$ - and **elevation head** - h - is constant along the stream line. This constant can be called **the total head** - H -.

The total head in a flow can be measured by the stagnation pressure using a pitot tube.

Energy and Hydraulic Grade Line Continued:

The Piezometric Head

The sum of pressure head - p / γ - and elevation head - h - is called **the piezometric head**. The piezometric head in a flow can be measured through an flat opening parallel to the flow.

Energy and Hydraulic Grade Line Continued:

The Energy Line

The Energy Line is a line that represents the total head available to the fluid and can be expressed as:

$$EL = H = p / \gamma + v^2 / 2 g + h = \text{constant along a streamline (3)}$$

where
 $EL = \text{Energy Line}$

For a fluid flow without any losses due to friction (major losses) or components (minor losses) the energy line would be at a constant level. In the practical world the energy line decreases along the flow due to the losses.

A turbine in the flow will reduce the energy line and a pump or fan will increase the energy line.

The Hydraulic Grade Line

The Hydraulic Grade Line is a line that represent the total head available to the fluid minus the velocity head and can be expressed as:

$$HGL = p / \gamma + h \quad (4)$$

where
 $HGL = \text{Hydraulic Grade Line}$

The hydraulic grade line lies one velocity head below the energy line.

Entrance Length and Developed Flow: Fluids need some length to develop the velocity profile after entering the pipe or after passing through components such as bends, valves, pumps, and turbines or similar.

The Entrance Length: The entrance length can be expressed with the dimensionless **Entrance Length Number:**

$$El = l_e / d \quad (1)$$

where
 $El = \text{Entrance Length Number}$
 $l_e = \text{length to fully developed velocity profile}$
 $d = \text{tube or duct diameter}$

The Entrance Length Number for Laminar Flow

The Entrance length number correlation with the Reynolds Number for laminar flow can be expressed as:

$$El_{laminar} = 0.06 Re \quad (2)$$

where
 $Re = \text{Reynolds Number}$

The Entrance Length Number for Turbulent Flow

The Entrance length number correlation with the Reynolds Number for turbulent flow can be expressed as:

$$El_{turbulent} = 4.4 Re^{1/6} \quad (3)$$

Entropy in Compressible Gas Flow: Calculating entropy in compressible gas flow
Entropy change in compressible gas flow can be expressed as

$$ds = c_v \ln(T_2 / T_1) + R \ln(\rho_1 / \rho_2) \quad (1)$$

or

$$ds = c_p \ln(T_2 / T_1) - R \ln(p_2 / p_1) \quad (2)$$

where

ds = entropy change

c_v = specific heat capacity at a constant volume process

c_p = specific heat capacity at a constant pressure process

T = absolute temperature

R = individual gas constant

ρ = density of gas

p = absolute pressure

Equation of Continuity: The Law of Conservation of Mass states that mass can be neither created nor destroyed. Using the Mass Conservation Law on a **steady flow** process - flow where the flow rate doesn't change over time - through a control volume where the stored mass in the control volume doesn't change - implements that inflow equals outflow. This statement is called **the Equation of Continuity**. Common application where **the Equation of Continuity** can be used are pipes, tubes and ducts with flowing fluids and gases, rivers, overall processes as power plants, dairies, logistics in general, roads, computer networks and semiconductor technology and more.

The Equation of Continuity and can be expressed as:

$$m = \rho_{i1} v_{i1} A_{i1} + \rho_{i2} v_{i2} A_{i2} + \dots + \rho_{in} v_{in} A_{in} \\ = \rho_{o1} v_{o1} A_{o1} + \rho_{o2} v_{o2} A_{o2} + \dots + \rho_{om} v_{om} A_{om} \quad (1)$$

where

m = mass flow rate (kg/s)

ρ = density (kg/m³)

v = speed (m/s)

A = area (m²)

With uniform density equation (1) can be modified to

$$q = v_{i1} A_{i1} + v_{i2} A_{i2} + \dots + v_{in} A_{in} \\ = v_{o1} A_{o1} + v_{o2} A_{o2} + \dots + v_{om} A_{om} \quad (2)$$

where

q = flow rate (m³/s)

$\rho_{i1} = \rho_{i2} = \dots = \rho_{in} = \rho_{o1} = \rho_{o2} = \dots = \rho_{om}$

Example - Equation of Continuity

10 m³/h of water flows through a pipe of 100 mm inside diameter. The pipe is reduced to an inside dimension of 80 mm. Using equation (2) the velocity in the 100 mm pipe can be calculated as

$$(10 \text{ m}^3/\text{h})(1 / 3600 \text{ h/s}) = v_{100} (3.14 \times 0.1 \text{ (m)} \times 0.1 \text{ (m)} / 4)$$

or

$$v_{100} = (10 \text{ m}^3/\text{h})(1 / 3600 \text{ h/s}) / (3.14 \times 0.1 \text{ (m)} \times 0.1 \text{ (m)} / 4)$$

$$= \underline{0.35 \text{ m/s}}$$

Using equation (2) the velocity in the 80 mm pipe can be calculated

$$(10 \text{ m}^3/\text{h})(1 / 3600 \text{ h/s}) = v_{80} (3.14 \times 0.08 \text{ (m)} \times 0.08 \text{ (m)} / 4)$$

or

$$v_{100} = (10 \text{ m}^3/\text{h})(1 / 3600 \text{ h/s}) / (3.14 \times 0.08 \text{ (m)} \times 0.08 \text{ (m)} / 4)$$

$$= \underline{0.55 \text{ m/s}}$$

Equation of Mechanical Energy: The Energy Equation is a statement of the first law of thermodynamics. The energy equation involves energy, heat transfer and work. With certain limitations the mechanical energy equation can be compared to the Bernoulli Equation and transferred to the Mechanical Energy Equation in Terms of Energy per Unit Mass.

The mechanical energy equation for a **pump or a fan** can be written in terms of **energy per unit mass**:

$$p_{in} / \rho + v_{in}^2 / 2 + g h_{in} + w_{shaft} = p_{out} / \rho + v_{out}^2 / 2 + g h_{out} + w_{loss} \quad (1)$$

where

p = static pressure

ρ = density

v = flow velocity

g = acceleration of gravity

h = elevation height

w_{shaft} = net shaft energy in per unit mass for a pump, fan or similar

w_{loss} = loss due to friction

The energy equation is often used for incompressible flow problems and is called **the Mechanical Energy Equation** or **the Extended Bernoulli Equation**.

The mechanical energy equation for a **turbine** can be written as:

$$p_{in} / \rho + v_{in}^2 / 2 + g h_{in} = p_{out} / \rho + v_{out}^2 / 2 + g h_{out} + w_{shaft} + w_{loss} \quad (2)$$

where

w_{shaft} = net shaft energy out per unit mass for a turbine or similar

Equation (1) and (2) dimensions are

energy per unit mass ($\text{ft}^2/\text{s}^2 = \text{ft lb}/\text{slug}$ or $\text{m}^2/\text{s}^2 = \text{N m}/\text{kg}$)

Efficiency

According to (1) a larger amount of loss - w_{loss} - result in more shaft work required for the same rise of output energy. The efficiency of a **pump or fan process** can be expressed as:

$$\eta = (w_{shaft} - w_{loss}) / w_{shaft} \quad (3)$$

The efficiency of a **turbine process** can be expressed as:

$$\eta = w_{shaft} / (w_{shaft} + w_{loss}) \quad (4)$$

The Mechanical Energy Equation in Terms of Energy per Unit Volume

The mechanical energy equation for a **pump or a fan** (1) can also be written in terms of **energy per unit volume** by multiplying (1) with fluid density - ρ :

$$\rho_{in} + \rho v_{in}^2 / 2 + \gamma h_{in} + \rho W_{shaft} = \rho_{out} + \rho v_{out}^2 / 2 + \gamma h_{out} + W_{loss} \quad (5)$$

where

$$\gamma = \rho g = \text{specific weight}$$

The dimensions of equation (5) are

$$\text{energy per unit volume (ft.lbf/ft}^3 = \text{lb/ft}^2 \text{ or N.m/m}^3 = \text{N/m}^2)$$

The Mechanical Energy Equation in Terms of Energy per Unit Weight involves Heads

The mechanical energy equation for a **pump or a fan** (1) can also be written in terms of **energy per unit weight** by dividing with gravity - g :

$$p_{in} / \gamma + v_{in}^2 / 2 g + h_{in} + h_{shaft} = p_{out} / \gamma + v_{out}^2 / 2 g + h_{out} + h_{loss} \quad (6)$$

where

$$\gamma = \rho g = \text{specific weight}$$

$$h_{shaft} = W_{shaft} / g = \text{net shaft energy head inn per unit mass for a pump, fan or similar}$$

$$h_{loss} = W_{loss} / g = \text{loss head due to friction}$$

The dimensions of equation (6) are

$$\text{energy per unit weight (ft.lbf/lb} = \text{ft or N.m/N} = \text{m)}$$

Head is the energy per unit weight.

h_{shaft} can also be expressed as:

$$h_{shaft} = W_{shaft} / g = W_{shaft} / m g = W_{shaft} / \gamma Q \quad (7)$$

where

$$W_{shaft} = \text{shaft power}$$

$$m = \text{mass flow rate}$$

$$Q = \text{volume flow rate}$$

Example - Pumping Water

Water is pumped from an open tank at level zero to an open tank at level 10 ft. The pump adds four horsepowers to the water when pumping 2 ft³/s.

Since $v_{in} = v_{out} = 0$, $p_{in} = p_{out} = 0$ and $h_{in} = 0$ - equation (6) can be modified to:

$$h_{shaft} = h_{out} + h_{loss}$$

or

$$h_{loss} = h_{shaft} - h_{out} \quad (8)$$

Equation (7) gives:

- $$h_{shaft} = W_{shaft} / \gamma Q = (4 \text{ hp})(550 \text{ ft}\cdot\text{lb/s}/\text{hp}) / (62.4 \text{ lb}/\text{ft}^3)(2 \text{ ft}^3/\text{s}) = 17.6 \text{ ft}$$
- specific weight of water 62.4 lb/ft³
 - 1 hp (English horse power) = 550 ft. lb/s

Combined with (8):

$$h_{loss} = (17.6 \text{ ft}) - (10 \text{ ft}) = 7.6 \text{ ft}$$

The pump efficiency can be calculated from (3) modified for head:

$$\eta = ((17.6 \text{ ft}) - (7.6 \text{ ft})) / (17.6 \text{ ft}) = 0.58$$

Equations in Fluid Mechanics: Common fluid mechanics equations - Bernoulli, conservation of energy, conservation of mass, pressure, Navier-Stokes, ideal gas law, Euler equations, Laplace equations, Darcy-Weisbach Equation and the following:

The Bernoulli Equation

- The Bernoulli Equation - A statement of the conservation of energy in a form useful for solving problems involving fluids. For a non-viscous, incompressible fluid in steady flow, the sum of pressure, potential and kinetic energies per unit volume is constant at any point.

Conservation laws

- The conservation laws states that particular measurable properties of an isolated physical system does not change as the system evolves.
- Conservation of energy (including mass)
- Fluid Mechanics and Conservation of Mass - The law of conservation of mass states that mass can neither be created nor destroyed.
- The Continuity Equation - The Continuity Equation is a statement that mass is conserved.

Darcy-Weisbach Equation

- Pressure Loss and Head Loss due to Friction in Ducts and Tubes - Major loss - head loss or pressure loss - due to friction in pipes and ducts.

Euler Equations

- In fluid dynamics, the Euler equations govern the motion of a compressible, inviscid fluid. They correspond to the Navier-Stokes equations with zero viscosity, although they are usually written in the form shown here because this emphasizes the fact that they directly represent conservation of mass, momentum, and energy.

Laplace's Equation

- The Laplace Equation describes the behavior of gravitational, electric, and fluid potentials.

Ideal Gas Law

- The Ideal Gas Law - For a perfect or ideal gas, the change in density is directly related to the change in temperature and pressure as expressed in the Ideal Gas Law.
- Properties of Gas Mixtures - Special care must be taken for gas mixtures when using the ideal gas law, calculating the mass, the individual gas constant or the density.
- The Individual and Universal Gas Constant - The Individual and Universal Gas Constant is common in fluid mechanics and thermodynamics.

Navier-Stokes Equations

- The motion of a non-turbulent, Newtonian fluid is governed by the Navier-Stokes equations. The equation can be used to model turbulent flow, where the fluid parameters are interpreted as time-averaged values.

Mechanical Energy Equation

- The Mechanical Energy Equation - The mechanical energy equation in Terms of Energy per Unit Mass, in Terms of Energy per Unit Volume and in Terms of Energy per Unit Weight involves Heads.

Pressure

- Static Pressure and Pressure Head in a Fluid - Pressure and pressure head in a static fluid.

Euler Equations: In fluid dynamics, the Euler equations govern the motion of a compressible, inviscid fluid. They correspond to the Navier-Stokes equations with zero viscosity, although they are usually written in the form shown here because this emphasizes the fact that they directly represent conservation of mass, momentum, and energy.

Euler Number: The Euler numbers, also called the secant numbers or zig numbers, are defined for $|x| < \pi/2$ by

$$\operatorname{sech} x - 1 \equiv -\frac{E_1^* x^2}{2!} + \frac{E_2^* x^4}{4!} - \frac{E_3^* x^6}{6!} + \dots$$
$$\sec x - 1 \equiv \frac{E_1^* x^2}{2!} + \frac{E_2^* x^4}{4!} + \frac{E_3^* x^6}{6!} + \dots$$

where $\operatorname{sech}(z)$ the hyperbolic secant and \sec is the secant. Euler numbers give the number of odd alternating permutations and are related to Genocchi numbers. The base e of the natural logarithm is sometimes known as Euler's number. A different sort of Euler number, the Euler number of a finite complex K , is defined by

$$\chi(K) = \sum (-1)^p \operatorname{rank}(C_p(K)).$$

This Euler number is a topological invariant. To confuse matters further, the Euler characteristic is sometimes also called the "Euler number," and numbers produced by the prime-generating polynomial $x^2 - x + 41$ are sometimes called "Euler numbers" (Flannery and Flannery 2000, p. 47).

F

Fecal Coliform: A group of bacteria that may indicate the presence of human or animal fecal matter in water.

Filtration: A series of processes that physically remove particles from water.

Flood Rim: The point of an object where the water would run over the edge of something and begin to cause a flood. See Air Break.

Fluids: A fluid is defined as a substance that continually deforms (flows) under an applied shear stress regardless of the magnitude of the applied stress. It is a subset of the phases of matter and includes liquids, gases, plasmas and, to some extent, plastic solids. Fluids are also divided into liquids and gases. Liquids form a free surface (that is, a surface not created by their container) while gases do not.

The distinction between solids and fluids is not so obvious. The distinction is made by evaluating the viscosity of the matter: for example silly putty can be considered either a solid or a fluid, depending on the time period over which it is observed. Fluids share the properties of not resisting deformation and the ability to flow (also described as their ability to take on the shape of their containers).

These properties are typically a function of their inability to support a shear stress in static equilibrium. While in a solid, stress is a function of strain, in a fluid, stress is a function of rate of strain. A consequence of this behavior is Pascal's law which entails the important role of pressure in characterizing a fluid's state. Based on how the stress depends on the rate of strain and its derivatives, fluids can be characterized as: Newtonian fluids: where stress is directly proportional to rate of strain, and Non-Newtonian fluids: where stress is proportional to rate of strain, its higher powers and derivatives (basically everything other than Newtonian fluid).

The behavior of fluids can be described by a set of partial differential equations, which are based on the conservation of mass, linear and angular momentum (Navier-Stokes equations) and energy. The study of fluids is fluid mechanics, which is subdivided into fluid dynamics and fluid statics depending on whether the fluid is in motion or not. Fluid **Related Information:** The Bernoulli Equation - A statement of the conservation of energy in a form useful for solving problems involving fluids. For a non-viscous, incompressible fluid in steady flow, the sum of pressure, potential and kinetic energies per unit volume is constant at any point. Equations in Fluid Mechanics - Continuity, Euler, Bernoulli, Dynamic and Total Pressure. Laminar, Transitional or Turbulent Flow? - It is important to know if the fluid flow is laminar, transitional or turbulent when calculating heat transfer or pressure and head loss.

Friction Head: The head required to overcome the friction at the interior surface of a conductor and between fluid particles in motion. It varies with flow, size, type and conditions of conductors and fittings, and the fluid characteristics.

G

Gas: A gas is one of the four major phases of matter (after solid and liquid, and followed by plasma) that subsequently appear as solid material when they are subjected to increasingly higher temperatures. Thus, as energy in the form of heat is added, a solid (e.g., ice) will first melt to become a liquid (e.g., water), which will then boil or evaporate to become a gas (e.g., water vapor). In some circumstances, a solid (e.g., "dry ice") can directly turn into a gas: this is called sublimation. If the gas is further heated, its atoms or molecules can become (wholly or partially) ionized, turning the gas into a plasma. **Relater Gas Information:** The Ideal Gas Law - For a perfect or ideal gas the change in density is directly related to the change in temperature and pressure as expressed in the Ideal Gas Law. Properties of Gas Mixtures - Special care must be taken for gas mixtures when using the ideal gas law, calculating the mass, the individual gas constant or the density. The Individual and

Universal Gas Constant - The Individual and Universal Gas Constant is common in fluid mechanics and thermodynamics.

Gauge Pressure: Pressure differential above or below ambient atmospheric pressure.

H

Hazardous Atmosphere: An atmosphere which by reason of being explosive, flammable, poisonous, corrosive, oxidizing, irritating, oxygen deficient, toxic, or otherwise harmful, may cause death, illness, or injury.

Hazen-Williams Factor: Hazen-Williams factor for some common piping materials. Hazen-Williams coefficients are used in the Hazen-Williams equation for friction loss calculation in ducts and pipes.

Hazen-Williams Equation - Calculating Friction Head Loss in Water Pipes

Friction head loss (ft H₂O per 100 ft pipe) in water pipes can be obtained by using the empirical Hazen-Williams equation. The Darcy-Weisbach equation with the Moody diagram are considered to be the most accurate model for estimating frictional head loss in steady pipe flow. Since the approach requires a not so efficient trial and error solution, an alternative empirical head loss calculation that does not require the trial and error solutions, as the Hazen-Williams equation, may be preferred:

$$f = 0.2083 (100/c)^{1.852} q^{1.852} / d_h^{4.8655} \quad (1)$$

where

f = friction head loss in feet of water per 100 feet of pipe (ft_{H₂O}/100 ft pipe)

c = Hazen-Williams roughness constant

q = volume flow (gal/min)

d_h = inside hydraulic diameter (inches)

Note that the Hazen-Williams formula is empirical and lacks physical basis. Be aware that the roughness constants are based on "normal" condition with approximately 1 m/s (3 ft/sec).

The Hazen-Williams formula is not the only empirical formula available. Manning's formula is common for gravity driven flows in open channels.

The flow velocity may be calculated as:

$$v = 0.4087 q / d_h^2$$

where

v = flow velocity (ft/s)

The Hazen-Williams formula can be assumed to be relatively accurate for piping systems where the Reynolds Number is above 10^5 (turbulent flow).

- 1 ft (foot) = 0.3048 m
- 1 in (inch) = 25.4 mm

- 1 gal (US)/min = $6.30888 \times 10^{-5} \text{ m}^3/\text{s}$ = 0.0227 m³/h = 0.0631 dm³(liter)/s = $2.228 \times 10^{-3} \text{ ft}^3/\text{s}$ = 0.1337 ft³/min = 0.8327 Imperial gal (UK)/min

Note! The Hazen-Williams formula gives accurate head loss due to friction for fluids with kinematic viscosity of approximately 1.1 cSt. More about fluids and kinematic viscosity.

The results for the formula are acceptable for cold water at 60° F (15.6° C) with kinematic viscosity 1.13 cSt. For hot water with a lower kinematic viscosity (0.55 cSt at 130° F (54.4° C)) the error will be significant. Since the Hazen Williams method is only valid for water flowing at ordinary temperatures between 40 to 75° F, the Darcy Weisbach method should be used for other liquids or gases.

Head: The height of a column or body of fluid above a given point expressed in linear units. Head is often used to indicate gauge pressure. Pressure is equal to the height times the density of the liquid. The measure of the pressure of water expressed in feet of height of water. 1 psi = 2.31 feet of water. There are various types of heads of water depending upon what is being measured. Static (water at rest) and Residual (water at flow conditions).

Hydraulics: Hydraulics is a branch of science and engineering concerned with the use of liquids to perform mechanical tasks.

Hydrodynamics: Hydrodynamics is the fluid dynamics applied to liquids, such as water, alcohol, and oil.

I

Ideal Gas: The Ideal Gas Law - For a perfect or ideal gas the change in density is directly related to the change in temperature and pressure as expressed in the Ideal Gas Law. Properties of Gas Mixtures - Special care must be taken for gas mixtures when using the ideal gas law, calculating the mass, the individual gas constant or the density. The Individual and Universal Gas Constant - The Individual and Universal Gas Constant is common in fluid mechanics and thermodynamics.

Isentropic Compression/Expansion Process: If the compression or expansion takes place under constant volume conditions - the process is called **isentropic**. The isentropic process on the basis of the Ideal Gas Law can be expressed as:

$$p / \rho^k = \text{constant} \quad (2)$$

where

$k = c_p / c_v$ - the ratio of specific heats - the ratio of specific heat at constant pressure - c_p - to the specific heat at constant volume - c_v

Irrigation: Water that is especially furnished to help provide and sustain the life of growing plants. It comes from ditches. It is sometimes treated with herbicides and pesticides to prevent the growth of weeds and the development of bugs in a lawn and a garden.

K

Kinematic Viscosity: The ratio of absolute or dynamic viscosity to density - a quantity in which no force is involved. Kinematic viscosity can be obtained by dividing the absolute viscosity of a fluid with its mass density as

$$v = \mu / \rho \quad (2)$$

where

v = kinematic viscosity

μ = absolute or dynamic viscosity

ρ = density

In the SI-system the theoretical unit is m^2/s or commonly used **Stoke (St)** where

- $1 \text{ St} = 10^{-4} m^2/s$

Since the Stoke is an unpractical large unit, it is usual divided by 100 to give the unit called **Centistokes (cSt)** where

$$1 \text{ St} = 100 \text{ cSt}$$

$$1 \text{ cSt} = 10^{-6} m^2/s$$

Since the specific gravity of water at 68.4°F (20.2°C) is almost one - 1, the kinematic viscosity of water at 68.4°F is for all practical purposes 1.0 cSt.

Kinetic Energy: The ability of an object to do work by virtue of its motion. The energy terms that are used to describe the operation of a pump are pressure and head.

Knudsen Number: Used by modelers who wish to express a non-dimensionless speed.

L

Laminar Flow: The resistance to flow in a liquid can be characterized in terms of the viscosity of the fluid if the flow is smooth. In the case of a moving plate in a liquid, it is found that there is a layer or lamina which moves with the plate, and a layer which is essentially stationary if it is next to a stationary plate. There is a gradient of velocity as you move from the stationary to the moving plate, and the liquid tends to move in layers with successively higher speed. This is called laminar flow, or sometimes "streamlined" flow. Viscous resistance to flow can be modeled for laminar flow, but if the lamina break up into turbulence, it is very difficult to characterize the fluid flow.

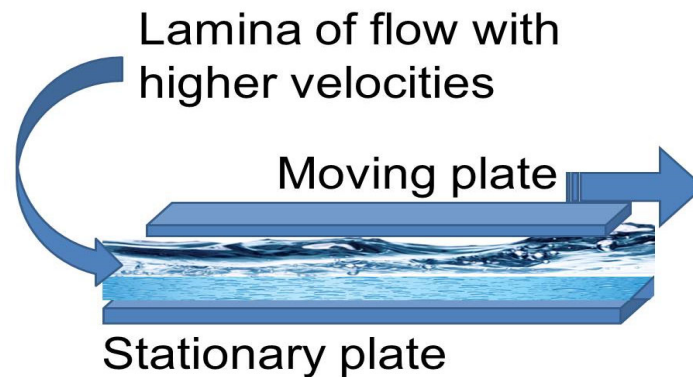

The common application of laminar flow would be in the smooth flow of a viscous liquid through a tube or pipe. In that case, the velocity of flow varies from zero at the walls to a maximum along the centerline of the vessel. The flow profile of laminar flow in a tube can be calculated by dividing the flow into thin cylindrical elements and applying the viscous force to them. Laminar, Transitional or Turbulent Flow? - It is important to know if the fluid flow is laminar, transitional or turbulent when calculating heat transfer or pressure and head loss.

Laplace's Equation: Describes the behavior of gravitational, electric, and fluid potentials.

The scalar form of Laplace's equation is the partial differential equation

$$\nabla^2 \psi = 0, \tag{1}$$

where ∇^2 is the Laplacian.

Note that the operator ∇^2 is commonly written as Δ by mathematicians (Krantz 1999, p. 16). Laplace's equation is a special case of the Helmholtz differential equation

$$\nabla^2 \psi + k^2 \psi = 0 \tag{2}$$

with $k = 0$, or Poisson's equation

$$\nabla^2 \psi = -4 \pi \rho \tag{3}$$

with $\rho = 0$.

The vector Laplace's equation is given by

$$\nabla^2 \mathbf{F} = \mathbf{0}. \tag{4}$$

A function ψ which satisfies Laplace's equation is said to be harmonic. A solution to Laplace's equation has the property that the average value over a spherical surface is equal to the value at the center of the sphere (Gauss's harmonic function theorem). Solutions have no local maxima or minima. Because Laplace's equation is linear, the superposition of any two solutions is also a solution.

Lift (Force): Lift consists of the sum of all the aerodynamic forces normal to the direction of the external airflow.

Liquids: An in-between state of matter. They can be found in between the solid and gas states. They don't have to be made up of the same compounds. If you have a variety of materials in a liquid, it is called a solution. One characteristic of a liquid is that it will fill up the shape of a container. If you pour some water in a cup, it will fill up the bottom of the cup first and then fill the rest. The water will also take the shape of the cup. It fills the bottom first because of **gravity**. The top part of a liquid will usually have a flat surface. That flat surface is because of gravity too. Putting an ice cube (solid) into a cup will leave you with a cube in the middle of the cup; the shape won't change until the ice becomes a liquid.

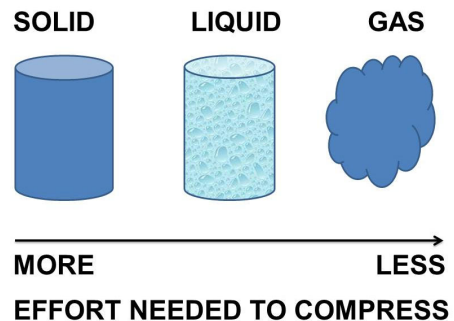

Another trait of liquids is that they are difficult to compress.

When you compress something, you take a certain amount and force it into a smaller space. Solids are very difficult to compress and gases are very easy. Liquids are in the middle but tend to be difficult. When you compress something, you force the atoms closer together. When pressure goes up, substances are compressed. Liquids already have their atoms close together, so they are hard to compress. Many shock absorbers in cars compress liquids in tubes.

A special force keeps liquids together. Solids are stuck together and you have to force them apart. Gases bounce everywhere and they try to spread themselves out. Liquids actually want to stick together. There will always be the occasional evaporation where extra energy gets a molecule excited and the molecule leaves the system. Overall, liquids have **cohesive** (sticky) forces at work that hold the molecules together. Related Liquid Information: Equations in Fluid Mechanics - Continuity, Euler, Bernoulli, Dynamic and Total Pressure

M

Mach Number: When an object travels through a medium, then its Mach number is the ratio of the object's speed to the speed of sound in that medium.

Magnetic Flow Meter: Inspection of magnetic flow meter instrumentation should include checking for corrosion or insulation deterioration.

Manning Formula for Gravity Flow: Manning's equation can be used to calculate cross-sectional average velocity flow in open channels

$$v = k_n/n R^{2/3} S^{1/2} \quad (1)$$

where

v = cross-sectional average velocity (ft/s, m/s)

$k_n = 1.486$ for English units and $k_n = 1.0$ for SI units

A = cross sectional area of flow (ft², m²)

n = Manning coefficient of roughness

R = hydraulic radius (ft, m)

S = slope of pipe (ft/ft, m/m)

The volume flow in the channel can be calculated as

$$q = A v = A k_n/n R^{2/3} S^{1/2} \quad (2)$$

where

q = volume flow (ft³/s, m³/s)

A = cross-sectional area of flow (ft², m²)

Maximum Contamination Levels or (MCLs): The maximum allowable level of a contaminant that federal or state regulations allow in a public water system. If the MCL is exceeded, the water system must treat the water so that it meets the MCL. Or provide adequate backflow protection.

Mechanical Seal: A mechanical device used to control leakage from the stuffing box of a pump. Usually made of two flat surfaces, one of which rotates on the shaft. The two flat surfaces are of such tolerances as to prevent the passage of water between them.

Mg/L: milligrams per liter

Microbe, Microbial: Any minute, simple, single-celled form of life, especially one that causes disease.

Microbial Contaminants: Microscopic organisms present in untreated water that can cause waterborne diseases.

ML: milliliter

N

Navier-Stokes Equations: The motion of a non-turbulent, Newtonian fluid is governed by the Navier-Stokes equation. The equation can be used to model turbulent flow, where the fluid parameters are interpreted as time-averaged values.

Newtonian Fluid: Newtonian fluid (named for Isaac Newton) is a fluid that flows like water—its shear stress is linearly proportional to the velocity gradient in the direction perpendicular to the plane of shear. The constant of proportionality is known as the viscosity. Water is Newtonian, because it continues to exemplify fluid properties no matter how fast it is stirred or mixed.

Contrast this with a non-Newtonian fluid, in which stirring can leave a "hole" behind (that gradually fills up over time - this behavior is seen in materials such as pudding, or to a less rigorous extent, sand), or cause the fluid to become thinner, the drop in viscosity causing it to flow more (this is seen in non-drip paints). For a Newtonian fluid, the viscosity, by definition, depends only on temperature and pressure (and also the chemical composition of the fluid if the fluid is not a pure substance), not on the forces acting upon it. If the fluid is incompressible and viscosity is constant across the fluid, the equation governing the shear stress. Related Newtonian Information: A Fluid is Newtonian if viscosity is constant applied to shear force. Dynamic, Absolute and Kinematic Viscosity - An introduction to dynamic, absolute and kinematic viscosity and how to convert between CentiStokes (cSt), CentiPouises (cP), Saybolt Universal Seconds (SSU) and degree Engler.

Newton's Third Law: Newton's third law describes the forces acting on objects interacting with each other. Newton's third law can be expressed as

- *"If one object exerts a force F on another object, then the second object exerts an equal but opposite force F on the first object"*

Force is a convenient abstraction to represent mentally the pushing and pulling interaction between objects. It is common to express forces as vectors with magnitude, direction and point of application. The net effect of two or more forces acting on the same point is the vector sum of the forces.

Non-Newtonian Fluid: Non-Newtonian fluid viscosity changes with the applied shear force.

P

Pascal's Law: A pressure applied to a confined fluid at rest is transmitted with equal intensity throughout the fluid.

Pathogens: Disease-causing pathogens; waterborne pathogens. A pathogen is a bacterium, virus or parasite that causes or is capable of causing disease. Pathogens may contaminate water and cause waterborne disease.

pCi/L- picocuries per liter: A curie is the amount of radiation released by a set amount of a certain compound. A picocurie is one quadrillionth of a curie.

pH: A measure of the acidity of water. The pH scale runs from 0 to 14 with 7 being the mid-point or neutral. A pH of less than 7 is on the acid side of the scale with 0 as the point of greatest acid activity. A pH of more than 7 is on the basic (alkaline) side of the scale with 14 as the point of greatest basic activity. pH (Power of Hydroxyl Ion Activity).

Pipeline Appurtenances: Pressure reducers, bends, valves, regulators (which are a type of valve), etc.

Peak Demand: The maximum momentary load placed on a water treatment plant, pumping station or distribution system is the Peak Demand.

Pipe Velocities: For calculating fluid pipe velocity.

Imperial units

A fluids flow velocity in pipes can be calculated with Imperial or American units as

$$v = 0.4085 q / d^2 \quad (1)$$

where

v = velocity (ft/s)

q = volume flow (US gal. /min)

d = pipe inside diameter (inches)

SI units

A fluids flow velocity in pipes can be calculated with SI units as

$$v = 1.274 q / d^2 \quad (2)$$

where

v = velocity (m/s)

q = volume flow (m³/s)

d = pipe inside diameter (m)

Pollution: To make something unclean or impure. Some states will have a definition of pollution that relates to non-health related water problems, like taste and odors. See Contaminated.

Positive Flow Report-back Signal: When a pump receives a signal to start, a light will typically be illuminated on the control panel indicating that the pump is running. In order to be sure that the pump is actually pumping water, a Positive flow report-back signal should be installed on the control panel.

Potable: Good water which is safe for drinking or cooking purposes. Non-Potable: A liquid or water that is not approved for drinking.

Potential Energy: The energy that a body has by virtue of its position or state enabling it to do work.

PPM: Abbreviation for parts per million.

Prandtl Number: The Prandtl Number is a dimensionless number approximating the ratio of momentum diffusivity and thermal diffusivity and can be expressed as

$$Pr = \nu / \alpha \quad (1)$$

where

Pr = Prandtl's number

ν = kinematic viscosity (Pa s)

α = thermal diffusivity (W/m K)

The Prandtl number can alternatively be expressed as

$$Pr = \mu c_p / k \quad (2)$$

where

μ = absolute or dynamic viscosity (kg/m s, cP)

c_p = specific heat capacity (J/kg K, Btu/(lb °F))

k = thermal conductivity (W/m K, Btu/(h ft² °F/ft))

The Prandtl Number is often used in heat transfer and free and forced convection calculations.

Pressure: An introduction to pressure - the definition and presentation of common units as psi and Pa and the relationship between them.

The pressure in a fluid is defined as

"the normal force per unit area exerted on an imaginary or real plane surface in a fluid or a gas"

The equation for pressure can be expressed as:

$$p = F / A \quad (1)$$

where

p = pressure [lb/in² (psi) or lb/ft² (psf), N/m² or kg/ms² (Pa)]

F = force [¹], N]

A = area [in² or ft², m²]

¹) In the English Engineering System special care must be taken for the force unit. The basic unit for mass is the pound mass (lb_m) and the unit for the force is the pound (lb) or pound force (lb_f).

Absolute Pressure

The **absolute pressure** - p_a - is measured relative to the *absolute zero pressure* - the pressure that would occur at absolute vacuum.

Gauge Pressure

A **gauge** is often used to measure the pressure difference between a system and the surrounding atmosphere. This pressure is often called the **gauge pressure** and can be expressed as

$$p_g = p_a - p_o \quad (2)$$

where

p_g = gauge pressure

p_o = atmospheric pressure

Atmospheric Pressure

The atmospheric pressure is the pressure in the surrounding air. It varies with temperature and altitude above sea level.

Standard Atmospheric Pressure

The **Standard Atmospheric Pressure** (atm) is used as a reference for gas densities and volumes. The Standard Atmospheric Pressure is defined at sea-level at 273°K (0°C) and is **1.01325 bar** or 101325 Pa (absolute). The temperature of 293°K (20°C) is also used.

In imperial units the Standard Atmospheric Pressure is 14.696 psi.

- $1 \text{ atm} = 1.01325 \text{ bar} = 101.3 \text{ kPa} = 14.696 \text{ psi (lb}_\#/\text{in}^2) = 760 \text{ mmHg} = 10.33 \text{ mH}_2\text{O} = 760 \text{ torr} = 29.92 \text{ in Hg} = 1013 \text{ mbar} = 1.0332 \text{ kg}_\#/\text{cm}^2 = 33.90 \text{ ftH}_2\text{O}$

Pressure Head: The height to which liquid can be raised by a given pressure.

Pressure Regulation Valves: Control water pressure and operate by restricting flows. They are used to deliver water from a high pressure to a low-pressure system. The pressure downstream from the valve regulates the amount of flow. Usually, these valves are of the globe design and have a spring-loaded diaphragm that sets the size of the opening.

Pressure Units: Since 1 Pa is a small pressure unit, the unit hectopascal (hPa) is widely used, especially in meteorology. The unit kilopascal (kPa) is commonly used designing technical applications like HVAC systems, piping systems and similar.

- $1 \text{ hectopascal} = 100 \text{ pascal} = 1 \text{ millibar}$
- $1 \text{ kilopascal} = 1000 \text{ pascal}$

Some Pressure Levels

- 10 Pa - The pressure at a depth of 1 mm of water
- 1 kPa - Approximately the pressure exerted by a 10 g mass on a 1 cm² area
- 10 kPa - The pressure at a depth of 1 m of water, or the drop in air pressure when going from sea level to 1000 m elevation
- 10 MPa - A "high pressure" washer forces the water out of the nozzles at this pressure
- 10 GPa - This pressure forms diamonds

Some Alternative Units of Pressure

- $1 \text{ bar} = 100,000 \text{ Pa}$
- $1 \text{ millibar} = 100 \text{ Pa}$

- 1 atmosphere - 101,325 Pa
- 1 mm Hg - 133 Pa
- 1 inch Hg - 3,386 Pa

A **torr** (torr) is named after Torricelli and is the pressure produced by a column of mercury 1 mm high equals to 1/760th of an atmosphere. 1 atm = 760 torr = 14.696 psi

Pounds per square inch (psi) was common in U.K. but has now been replaced in almost every country except in the U.S. by the SI units. The Normal atmospheric pressure is 14.696 psi, meaning that a column of air on one square inch in area rising from the Earth's atmosphere to space weighs 14.696 pounds.

The **bar** (bar) is common in the industry. One bar is 100,000 Pa, and for most practical purposes can be approximated to one atmosphere even if

$$1 \text{ Bar} = 0.9869 \text{ atm}$$

There are 1,000 **millibar** (mbar) in one bar, a unit common in meteorology.

$$1 \text{ millibar} = 0.001 \text{ bar} = 0.750 \text{ torr} = 100 \text{ Pa}$$

Q

R

Residual Disinfection/Protection: A required level of disinfectant that remains in treated water to ensure disinfection protection and prevent recontamination throughout the distribution system (i.e., pipes).

Reynolds Number: The Reynolds number is used to determine whether a flow is laminar or turbulent. The Reynolds Number is a non-dimensional parameter defined by the ratio of dynamic pressure (ρu^2) and shearing stress ($\mu u / L$) - and can be expressed as

$$\begin{aligned} Re &= (\rho u^2) / (\mu u / L) \\ &= \rho u L / \mu \\ &= u L / \nu \quad (1) \end{aligned}$$

where

Re = Reynolds Number (non-dimensional)

ρ = density (kg/m^3 , lb_m/ft^3)

u = velocity (m/s, ft/s)

μ = dynamic viscosity (Ns/m^2 , $\text{lb}_m/\text{s ft}$)

L = characteristic length (m, ft)

ν = kinematic viscosity (m^2/s , ft^2/s)

Richardson Number: A dimensionless number that expresses the ratio of potential to kinetic energy.

S

Sanitizer: A chemical which disinfects (kills bacteria), kills algae and oxidizes organic matter.

Saybolt Universal Seconds (or SUS, SSU): Saybolt Universal Seconds (or SUS) is used to measure viscosity. The efflux time is Saybolt Universal Seconds (SUS) required for 60 milliliters of a petroleum product to flow through the calibrated orifice of a Saybolt Universal viscometer, under carefully controlled temperature and as prescribed by test method ASTM D 88. This method has largely been replaced by the kinematic viscosity method. Saybolt Universal Seconds is also called the SSU number (Seconds Saybolt Universal) or SSF number (Saybolt Seconds Furol).

Kinematic viscosity versus dynamic or absolute viscosity can be expressed as

$$v = 4.63 \mu / SG \quad (3)$$

where

v = kinematic viscosity (SSU)

μ = dynamic or absolute viscosity (cP)

Scale: Crust of calcium carbonate, the result of unbalanced pool water. Hard insoluble minerals deposited (usually calcium bicarbonate) which forms on pool and spa surfaces and clog filters, heaters and pumps. Scale is caused by high calcium hardness and/or high pH. You will often find major scale deposits inside a backflow prevention assembly.

Shock: Also known as superchlorination or break point chlorination. Ridding a pool of organic waste through oxidization by the addition of significant quantities of a halogen.

Shock Wave: A shock wave is a strong pressure wave produced by explosions or other phenomena that create violent changes in pressure.

Solder: A fusible alloy used to join metallic parts. Solder for potable water pipes shall be lead-free.

Sound Barrier: The sound barrier is the apparent physical boundary stopping large objects from becoming supersonic.

Specific Gravity: The Specific Gravity - SG - is a dimensionless unit defined as the ratio of density of the material to the density of water at a specified temperature. Specific Gravity can be expressed as

$$SG = \rho / \rho_{H_2O} \quad (3)$$

where

SG = specific gravity

ρ = density of fluid or substance (kg/m^3)

ρ_{H_2O} = density of water (kg/m^3)

It is common to use the density of water at 4°C (39°F) as a reference - at this point the density of water is at the highest. Since Specific Weight is dimensionless it has the same value in the metric SI system as in the imperial English system (BG). At the reference point the Specific Gravity has same numerically value as density.

Example - Specific Gravity

If the density of iron is 7850 kg/m³, 7.85 grams per cubic millimeter, 7.85 kilograms per liter, or 7.85 metric tons per cubic meter - the specific gravity of iron is:

$$SG = 7850 \text{ kg/m}^3 / 1000 \text{ kg/m}^3$$

$$= \underline{7.85}$$

(the density of water is 1000 kg/m³)

Specific Weight: Specific Weight is defined as weight per unit volume. Weight is a force.

- Mass and Weight - the difference! - What is weight and what is mass? An explanation of the difference between weight and mass.

Specific Weight can be expressed as

$$\gamma = \rho g \text{ (2)}$$

where

γ = specific weight (kN/m³)

g = acceleration of gravity (m/s²)

The SI-units of specific weight are kN/m³. The imperial units are lb/ft³. The local acceleration g is under normal conditions 9.807 m/s² in SI-units and 32.174 ft/s² in imperial units.

Example - Specific Weight Water

Specific weight for water at 60 °F is 62.4 lb/ft³ in imperial units and 9.80 kN/m³ in SI-units.

Example - Specific Weight Some other Materials

Product	Specific Weight - γ	
	Imperial Units (lb/ft ³)	SI Units (kN/m ³)
Ethyl Alcohol	49.3	7.74
Gasoline	42.5	6.67
Glycerin	78.6	12.4
Mercury	847	133
SAE 20 Oil	57	8.95
Seawater	64	10.1
Water	62.4	9.80

Static Head: The height of a column or body of fluid above a given point

Static Pressure: The pressure in a fluid at rest.

Static Pressure and Pressure Head in Fluids: The pressure indicates the normal force per unit area at a given point acting on a given plane. Since there is no shearing stresses present in a fluid at rest - the pressure in a fluid is independent of direction.

For fluids - liquids or gases - at rest the pressure gradient in the vertical direction depends only on the specific weight of the fluid.

How pressure changes with elevation can be expressed as

$$dp = - \gamma dz \quad (1)$$

where

dp = change in pressure

dz = change in height

γ = specific weight

The pressure gradient in vertical direction is negative - the pressure decrease upwards.

Specific Weight: Specific Weight can be expressed as:

$$\gamma = \rho g \quad (2)$$

where

γ = specific weight

g = acceleration of gravity

In general the specific weight - γ - is constant for fluids. For gases the specific weight - γ - varies with the elevation.

Static Pressure in a Fluid: For an incompressible fluid - as a liquid - the pressure difference between two elevations can be expressed as:

$$p_2 - p_1 = - \gamma (z_2 - z_1) \quad (3)$$

where

p_2 = pressure at level 2

p_1 = pressure at level 1

z_2 = level 2

z_1 = level 1

(3) can be transformed to:

$$p_1 - p_2 = \gamma (z_2 - z_1) \quad (4)$$

or

$$p_1 - p_2 = \gamma h \quad (5)$$

where

$h = z_2 - z_1$ difference in elevation - the depth down from location z_2 .

or

$$p_1 = \gamma h + p_2 \quad (6)$$

Static Pressure and Pressure Head in Fluids Continued:

The Pressure Head

(6) can be transformed to:

$$h = (p_2 - p_1) / \gamma \quad (6)$$

h express **the pressure head** - the height of a column of fluid of specific weight - γ - required to give a pressure difference of $(p_2 - p_1)$.

Example - Pressure Head

A pressure difference of 5 psi (lbf/in²) is equivalent to

$$5 \text{ (lbf/in}^2\text{)} \cdot 12 \text{ (in/ft)} \cdot 12 \text{ (in/ft)} / 62.4 \text{ (lb/ft}^3\text{)} = \underline{11.6 \text{ ft of water}}$$

$$5 \text{ (lbf/in}^2\text{)} \cdot 12 \text{ (in/ft)} \cdot 12 \text{ (in/ft)} / 847 \text{ (lb/ft}^3\text{)} = \underline{0.85 \text{ ft of mercury}}$$

when specific weight of water is 62.4 (lb/ft³) and specific weight of mercury is 847 (lb/ft³).

Streamline - Stream Function: A streamline is the path that an imaginary particle would follow if it was embedded in the flow.

Strouhal Number: A quantity describing oscillating flow mechanisms. **The Strouhal Number** is a dimensionless value useful for analyzing oscillating, unsteady fluid flow dynamics problems.

The Strouhal Number can be expressed as

$$St = \omega l / v \text{ (1)}$$

where

St = Strouhal Number

ω = oscillation frequency

l = characteristic length

v = flow velocity

The Strouhal Number represents a measure of the ratio of inertial forces due to the unsteadiness of the flow or local acceleration to the inertial forces due to changes in velocity from one point to another in the flow field.

The vortices observed behind a stone in a river, or measured behind the obstruction in a vortex flow meter, illustrate these principles.

Stuffing Box: That portion of the pump which houses the packing or mechanical seal.

Submerged: To cover with water or liquid substance.

Supersonic Flow: Flow with speed above the speed of sound, 1,225 km/h at sea level, is said to be supersonic.

Surface Tension: Surface tension is a force within the surface layer of a liquid that causes the layer to behave as an elastic sheet. The cohesive forces between liquid molecules are responsible for the phenomenon known as surface tension. The molecules at the surface do not have other like molecules on all sides of them and consequently they cohere more strongly to those directly associated with them on the surface. This forms a surface "film" which makes it more difficult to move an object through the surface than to move it when it is completely submerged. Surface tension is typically measured in dynes/cm, the force in dynes required to break a film of length 1 cm. Equivalently, it can be stated as surface energy in ergs per square centimeter. Water at 20°C has a surface tension of 72.8 dynes/cm compared to 22.3 for ethyl alcohol and 465 for mercury.

Surface tension is typically measured in *dynes/cm* or *N/m*.

Liquid	Surface Tension	
	N/m	dynes/cm
Ethyl Alcohol	0.0223	22.3
Mercury	0.465	465
Water 20°C	0.0728	72.75
Water 100°C	0.0599	58.9

Surface tension is the energy required to stretch a unit change of a surface area. Surface tension will form a drop of liquid to a sphere since the sphere offers the smallest area for a definite volume.

Surface tension can be defined as

$$\sigma = F_s / l \quad (1)$$

where

σ = surface tension (N/m)

F_s = stretching force (N)

l = unit length (m)

Alternative Units

Alternatively, surface tension is typically measured in dynes/cm, which is

- the force in dynes required to break a film of length 1 cm
- or as surface energy J/m² or alternatively ergs per square centimeter.
- 1 dynes/cm = 0.001 N/m = 0.0000685 lb_f/ft = 0.571 10⁻⁵ lb_f/in = 0.0022 poundal/ft = 0.00018 poundal/in = 1.0 mN/m = 0.001 J/m² = 1.0 erg/cm² = 0.00010197 kg_f/m

Common Imperial units used are lb/ft and lb/in.

Water surface tension at different temperatures can be taken from the table below:

Temperature (°C)	Surface Tension - σ - (N/m)
0	0.0757
10	0.0742
20	0.0728
30	0.0712
40	0.0696
50	0.0679
60	0.0662
70	0.0644
80	0.0626
90	0.0608

Surface Tension of some common Fluids

- benzene : 0.0289 (N/m)
- diethyl ether : 0.0728 (N/m)
- carbon tetrachloride : 0.027 (N/m)
- chloroform : 0.0271 (N/m)
- ethanol : 0.0221 (N/m)
- ethylene glycol : 0.0477 (N/m)
- glycerol : 0.064 (N/m)
- mercury : 0.425 (N/m)
- methanol : 0.0227 (N/m)
- propanol : 0.0237 (N/m)
- toluene : 0.0284 (N/m)
- water at 20°C : 0.0729 (N/m)

Surge Tanks: Surge tanks can be used to control Water Hammer. A limitation of hydropneumatic tanks is that they do not provide much storage to meet peak demands during power outages and you have very limited time to do repairs on equipment.

T

Telemetry Systems: The following are common pressure sensing devices: Helical Sensor, Bourdon Tube, and Bellows Sensor. The most frequent problem that affects a liquid pressure-sensing device is air accumulation at the sensor. A diaphragm element being used as a level sensor would be used in conjunction with a pressure sensor. Devices must often transmit more than one signal. You can use several types of systems including: Polling, Scanning and Multiplexing. Transmitting equipment requires installation where temperature will not exceed 130 degrees F.

Thixotropic Fluids: Shear Thinning Fluids or Thixotropic Fluids reduce their viscosity as agitation or pressure is increased at a constant temperature. Ketchup and mayonnaise are examples of thixotropic materials. They appear thick or viscous but are possible to pump quite easily.

Transonic: Flow with speed at velocities just below and above the speed of sound is said to be transonic.

Turbidity: A measure of the cloudiness of water caused by suspended particles.

U

U-Tube Manometer: Pressure measuring devices using liquid columns in vertical or inclined tubes are called manometers. One of the most common is the water filled u-tube manometer used to measure pressure difference in pitot or orifices located in the airflow in air handling or ventilation systems.

V

Valve: A device that opens and closes to regulate the flow of liquids. Faucets, hose bibs, and Ball are examples of valves.

Vane: That portion of an impeller which throws the water toward the volute.

Vapor Pressure: For a particular substance at any given temperature there is a pressure at which the vapor of that substance is in equilibrium with its liquid or solid forms.

Velocity Head: The vertical distance a liquid must fall to acquire the velocity with which it flows through the piping system. For a given quantity of flow, the velocity head will vary indirectly as the pipe diameter varies.

Venturi: A system for speeding the flow of the fluid, by constricting it in a cone-shaped tube. Venturi are used to measure the speed of a fluid, by measuring the pressure changes from one point to another along the venture. A venturi can also be used to inject a liquid or a gas into another liquid. A pump forces the liquid flow through a tube connected to:

- A venturi to increase the speed of the fluid (restriction of the pipe diameter)
- A short piece of tube connected to the gas source
- A second venturi that decrease the speed of the fluid (the pipe diameter increase again)
- After the first venturi the pressure in the pipe is lower, so the gas is sucked in the pipe. Then the mixture enters the second venturi and slow down. At the end of the system a mixture of gas and liquid appears and the pressure rise again to its normal level in the pipe.
- This technique is used for ozone injection in water.

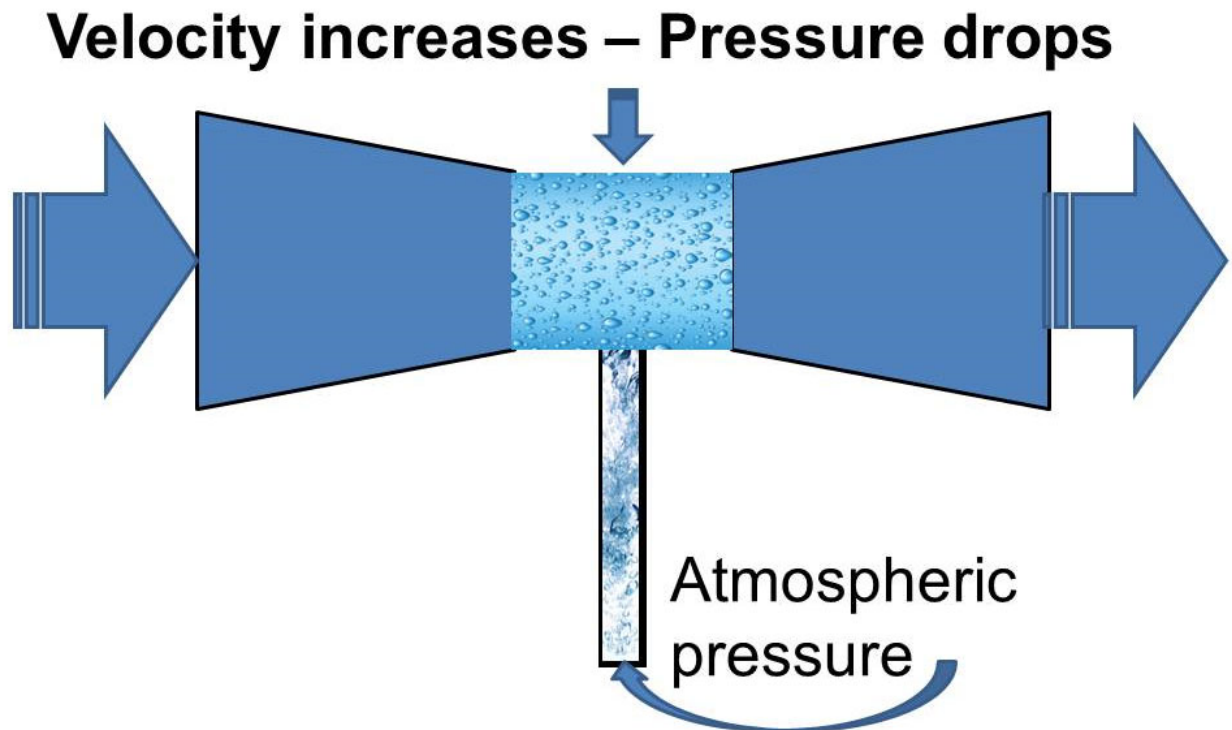

The newest injector design causes complete mixing of injected materials (air, ozone or chemicals), eliminating the need for other in-line mixers. Venturi injectors have no moving parts and are maintenance free. They operate effectively over a wide range of pressures (from 1 to 250 psi) and require only a minimum pressure difference to initiate the vacuum at the suction part. Venturis are often built in thermoplastics (PVC, PE, PVDF), stainless steel or other metals.

The cavitation effect at the injection chamber provides an instantaneous mixing, creating thousands of very tiny bubbles of gas in the liquid. The small bubbles provide an increased gas exposure to the liquid surface area, increasing the effectiveness of the process (i.e. ozonation).

Vibration: A force that is present on construction sites and must be considered. The vibrations caused by backhoes, dump trucks, compactors and traffic on job sites can be substantial.

Viscosity: Informally, viscosity is the quantity that describes a fluid's resistance to flow. Fluids resist the relative motion of immersed objects through them as well as to the motion of layers with differing velocities within them. Formally, viscosity (represented by the symbol η "eta") is the ratio of the shearing stress (F/A) to the velocity gradient ($\Delta v_x/\Delta z$ or dv_x/dz) in a fluid.

$$\eta = \left(\frac{F}{A} \right) \div \left(\frac{\Delta v_x}{\Delta z} \right) \quad \text{or} \quad \eta = \left(\frac{F}{A} \right) \div \left(\frac{dv_x}{dz} \right)$$

The more usual form of this relationship, called Newton's equation, states that the resulting shear of a fluid is directly proportional to the force applied and inversely proportional to its viscosity. The similarity to Newton's second law of motion ($F = ma$) should be apparent.

$$\frac{F}{A} = \eta \frac{\Delta v_x}{\Delta z} \quad \text{or} \quad \frac{F}{A} = \eta \frac{dv_x}{dz}$$

⇕

⇕

$$F = m \frac{\Delta v}{\Delta t} \quad \text{or} \quad F = m \frac{dv}{dt}$$

The SI unit of viscosity is the pascal second [Pa·s], which has no special name. Despite its self-proclaimed title as an international system, the International System of Units has had very little international impact on viscosity. The pascal second is rarely used in scientific and technical publications today. The most common unit of viscosity is the dyne second per square centimeter [dyne·s/cm²], which is given the name poise [P] after the French physiologist Jean Louis Poiseuille (1799-1869). Ten poise equal one pascal second [Pa·s] making the centipoise [cP] and millipascal second [mPa·s] identical.

$$\begin{aligned} 1 \text{ pascal second} &= 10 \text{ poise} = 1,000 \text{ millipascal second} \\ 1 \text{ centipoise} &= 1 \text{ millipascal second} \end{aligned}$$

There are actually two quantities that are called viscosity. The quantity defined above is sometimes called dynamic viscosity, absolute viscosity, or simple viscosity to distinguish it from the other quantity, but is usually just called viscosity. The other quantity called kinematic viscosity (represented by the symbol ν "nu") is the ratio of the viscosity of a fluid to its density.

$$v = \frac{\eta}{\rho}$$

Kinematic viscosity is a measure of the resistive flow of a fluid under the influence of gravity. It is frequently measured using a device called a capillary viscometer -- basically a graduated can with a narrow tube at the bottom. When two fluids of equal volume are placed in identical capillary viscometers and allowed to flow under the influence of gravity, a viscous fluid takes longer than a less viscous fluid to flow through the tube. Capillary viscometers are discussed in more detail later in this section.

The SI unit of kinematic viscosity is the square meter per second [m²/s], which has no special name. This unit is so large that it is rarely used. A more common unit of kinematic viscosity is the square centimeter per second [cm²/s], which is given the name stoke [St] after the English scientist George Stoke. This unit is also a bit too large and so the most common unit is probably the square millimeter per second [mm²/s] or centistoke [cSt].

Viscosity and Reference Temperatures: The viscosity of a fluid is highly temperature dependent and for either dynamic or kinematic viscosity to be meaningful, the **reference temperature** must be quoted. In ISO 8217 the reference temperature for a residual fluid is 100°C. For a distillate fluid the reference temperature is 40°C.

- For a liquid - the kinematic viscosity will **decrease** with higher temperature.
- For a gas - the kinematic viscosity will **increase** with higher temperature.

Volute: The spiral-shaped casing surrounding a pump impeller that collects the liquid discharged by the impeller.

Vorticity: Vorticity is defined as the circulation per unit area at a point in the flow field.

Vortex: A vortex is a whirlpool in the water.

W

Water Freezing: The effects of water freezing in storage tanks can be minimized by alternating water levels in the tank.

Water Storage Facility Inspection: During an inspection of your water storage facility, you should inspect the Cathodic protection system including checking the anode's condition and the connections. The concentration of polyphosphates that is used for corrosion control in storage tanks is typically 5 mg/L or less. External corrosion of steel water storage facilities can be reduced with Zinc or aluminum coatings. All storage facilities should be regularly sampled to determine the quality of water that enters and leaves the facility. One tool or piece of measuring equipment is the Jackson turbidimeter, which is a method to measure cloudiness in water.

Wave Drag: Wave drag refers to a sudden and very powerful drag that appears on aircrafts flying at high-subsonic speeds.

Water Purveyor: The individuals or organization responsible to help provide, supply, and furnish quality water to a community.

Water Works: All of the pipes, pumps, reservoirs, dams and buildings that make up a water system.

Waterborne Diseases: A disease, caused by a virus, bacterium, protozoan, or other microorganism, capable of being transmitted by water (e.g., typhoid fever, cholera, amoebic dysentery, gastroenteritis).

Weber Number: A dimensionless value useful for analyzing fluid flows where there is an interface between two different fluids.

Appendixes and Charts

Density of Common Liquids

The density of some common liquids can be found in the table below:

Liquid	Temperature - <i>t</i> - (°C)	Density - ρ - (kg/m ³)
Acetic Acid	25	1049
Acetone	25	785
Acetonitrile	20	782
Alcohol, ethyl	25	785
Alcohol, methyl	25	787
Alcohol, propyl	25	780
Ammonia (aqua)	25	823
Aniline	25	1019
Automobile oils	15	880 - 940
Beer (varies)	10	1010
Benzene	25	874
Benzyl	15	1230
Brine	15	1230
Bromine	25	3120
Butyric Acid	20	959
Butane	25	599
n-Butyl Acetate	20	880
n-Butyl Alcohol	20	810
n-Butylchloride	20	886
Caproic acid	25	921
Carbolic acid	15	956
Carbon disulfide	25	1261
Carbon tetrachloride	25	1584
Carene	25	857
Castor oil	25	956
Chloride	25	1560
Chlorobenzene	20	1106
Chloroform	20	1489
Chloroform	25	1465
Citric acid	25	1660
Coconut oil	15	924
Cotton seed oil	15	926
Cresol	25	1024
Creosote	15	1067
Crude oil, 48° API	60°F	790

Crude oil, 40° API	60°F	825
Crude oil, 35.6° API	60°F	847
Crude oil, 32.6° API	60°F	862
Crude oil, California	60°F	915
Crude oil, Mexican	60°F	973
Crude oil, Texas	60°F	873
Cumene	25	860
Cyclohexane	20	779
Cyclopentane	20	745
Decane	25	726
Diesel fuel oil 20 to 60	15	820 - 950
Diethyl ether	20	714
o-Dichlorobenzene	20	1306
Dichloromethane	20	1326
Diethylene glycol	15	1120
Dichloromethane	20	1326
Dimethyl Acetamide	20	942
N,N-Dimethylformamide	20	949
Dimethyl Sulfoxide	20	1100
Dodecane	25	755
Ethane	-89	570
Ether	25	73
Ethylamine	16	681
Ethyl Acetate	20	901
Ethyl Alcohol	20	789
Ethyl Ether	20	713
Ethylene Dichloride	20	1253
Ethylene glycol	25	1097
Fluorine refrigerant R-12	25	1311
Formaldehyde	45	812
Formic acid 10%oncentration	20	1025
Formic acid 80%oncentration	20	1221
Freon - 11	21	1490
Freon - 21	21	1370
Fuel oil	60°F	890
Furan	25	1416
Furforol	25	1155
Gasoline, natural	60°F	711
Gasoline, Vehicle	60°F	737
Gas oils	60°F	890
Glucose	60°F	1350 - 1440
Glycerin	25	1259

Glycerol	25	1126
Heptane	25	676
Hexane	25	655
Hexanol	25	811
Hexene	25	671
Hydrazine	25	795
Iodine	25	4927
Ionene	25	932
Isobutyl Alcohol	20	802
Iso-Octane	20	692
Isopropyl Alcohol	20	785
Isopropyl Myristate	20	853
Kerosene	60°F	817
Linolenic Acid	25	897
Linseed oil	25	929
Methane	-164	465
Methanol	20	791
Methyl Isoamyl Ketone	20	888
Methyl Isobutyl Ketone	20	801
Methyl n-Propyl Ketone	20	808
Methyl t-Butyl Ether	20	741
N-Methylpyrrolidone	20	1030
Methyl Ethyl Ketone	20	805
Milk	15	1020 - 1050
Naphtha	15	665
Naphtha, wood	25	960
Napthalene	25	820
Ocimene	25	798
Octane	15	918
Olive oil	20	800 - 920
Oxygen (liquid)	-183	1140
Palmitic Acid	25	851
Pentane	20	626
Pentane	25	625
Petroleum Ether	20	640
Petrol, natural	60°F	711
Petrol, Vehicle	60°F	737
Phenol	25	1072
Phosgene	0	1378
Phytadiene	25	823
Pinene	25	857
Propane	-40	583

Propane, R-290	25	494
Propanol	25	804
Propylenearbonate	20	1201
Propylene	25	514
Propylene glycol	25	965
Pyridine	25	979
Pyrrole	25	966
Rape seed oil	20	920
Resorcinol	25	1269
Rosin oil	15	980
Sea water	25	1025
Silane	25	718
Silicone oil		760
Sodium Hydroxide (caustic soda)	15	1250
Sorbaldehyde	25	895
Soya bean oil	15	924 - 928
Stearic Acid	25	891
Sulphuric Acid 95%onc.	20	1839
Sugar solution 68 brix	15	1338
Sunflower oil	20	920
Styrene	25	903
Terpinene	25	847
Tetrahydrofuran	20	888
Toluene	20	867
Toluene	25	862
Triethylamine	20	728
Trifluoroacetic Acid	20	1489
Turpentine	25	868
Water - pure	4	1000
Water - sea	77°F	1022
Whale oil	15	925
o-Xylene	20	880

$1 \text{ kg/m}^3 = 0.001 \text{ g/cm}^3 = 0.0005780 \text{ oz/in}^3 = 0.16036 \text{ oz/gal (Imperial)} = 0.1335 \text{ oz/gal (U.S.)} = 0.0624 \text{ lb/ft}^3 = 0.000036127 \text{ lb/in}^3 = 1.6856 \text{ lb/yd}^3 = 0.010022 \text{ lb/gal (Imperial)} = 0.008345 \text{ lb/gal (U.S.)} = 0.0007525 \text{ ton/yd}^3$

Dynamic or Absolute Viscosity Units Converting Table

The table below can be used to convert between common dynamic or absolute viscosity units.

Multiply by	Convert to				
Convert from	Poiseuille (Pa s)	Poise (dyne s / cm ² = g / cm s)	centiPoise	kg / m h	kg _f s / m ²
Poiseuille (Pa s)	1	10	10 ³	3.63 10 ³	0.102
Poise (dyne s / cm ² = g / cm s)	0.1	1	100	360	0.0102
centiPoise	0.001	0.01	1	3.6	0.00012
kg / m h	2.78 10 ⁻⁴	0.00278	0.0278	1	2.83 10 ⁻⁵
kg _f s / m ²	9.81	98.1	9.81 10 ³	3.53 10 ⁴	1
lb _f s / inch ²	6.89 10 ³	6.89 10 ⁴	6.89 10 ⁶	2.48 10 ⁷	703
lb _f s / ft ²	47.9	479	4.79 10 ⁴	1.72 10 ⁵	0.0488
lb _f h / ft ²	1.72 10 ⁵	1.72 10 ⁶	1.72 10 ⁸	6.21 10 ⁸	1.76 10 ⁴
lb / ft s	1.49	14.9	1.49 10 ³	5.36 10 ³	0.152
lb / ft h	4.13 10 ⁻⁴	0.00413	0.413	1.49	4.22 10 ⁻⁵
Multiply by	Convert to				
Convert from	lb _f s / inch ²	lb _f s / ft ²	lb _f h / ft ²	lb / ft s	lb / ft h
Poiseuille (Pa s)	1.45 10 ⁻⁴	0.0209	5.8 10 ⁻⁶	0.672	2.42 10 ³
Poise (dyne s / cm ² = g / cm s)	1.45 10 ⁻⁵	0.00209	5.8 10 ⁻⁷	0.0672	242
centiPoise	1.45 10 ⁻⁷	2.9 10 ⁻⁵	5.8 10 ⁻⁹	0.000672	2.42
kg / m h	4.03 10 ⁻⁸	5.8 10 ⁻⁶	1.61 10 ⁻⁹	0.000187	0.672
kg _f s / m ²	0.00142	20.5	5.69 10 ⁻⁵	6.59	2.37 10 ⁴
lb _f s / inch ²	1	144	0.04	4.63 10 ³	1.67 10 ⁷
lb _f s / ft ²	0.00694	1	0.000278	32.2	1.16 10 ⁵
lb _f h / ft ²	25	3.6 10 ³	1	1.16 10 ⁵	4.17 10 ⁸
lb / ft s	0.000216	0.0311	8.63 10 ⁻⁶	1	3.6 10 ³
lb / ft h	6 10 ⁻⁸	1.16 10 ⁵	2.4 10 ⁻⁹	0.000278	1

Friction Loss Chart

The table below can be used to indicate the friction loss - feet of liquid per 100 feet of pipe - in standard schedule 40 steel pipes.

Pipe Size (inches)	Flow Rate		Kinematic Viscosity - SSU					
	(gpm)	(l/s)	31 (Water)	100 (~Cream)	200 (~Vegetable oil)	400 (~SAE 10 oil)	800 (~Tomato juice)	1500 (~SAE 30 oil)
1/2	3	0.19	10.0	25.7	54.4	108.0	218.0	411.0
3/4	3	0.19	2.5	8.5	17.5	35.5	71.0	131.0
	5	0.32	6.3	14.1	29.3	59.0	117.0	219.0
1	3	0.19	0.8	3.2	6.6	13.4	26.6	50.0
	5	0.32	1.9	5.3	11.0	22.4	44.0	83.0
	10	0.63	6.9	11.2	22.4	45.0	89.0	165.0
	15	0.95	14.6	26.0	34.0	67.0	137.0	
	20	1.26	25.1	46	46.0	90.0	180.0	
1 1/4	5	0.32	0.5	1.8	3.7	7.6	14.8	26.0
	10	0.63	1.8	3.6	7.5	14.9	30.0	55.0
	15	0.95	3.7	6.4	11.3	22.4	45.0	84.0
1 1/2	10	0.63	0.8	1.9	4.2	8.1	16.5	31.0
	15	0.95	1.7	2.8	6.2	12.4	25.0	46.0
	20	1.26	2.9	5.3	8.1	16.2	33.0	61.0
	30	1.9	6.3	11.6	12.2	24.3	50.0	91.0
	40	2.5	10.8	19.6	20.8	32.0	65.0	121.0
2	20	1.26	0.9	1.5	3.0	6.0	11.9	22.4
	30	1.9	1.8	3.2	4.4	9.0	17.8	33.0
	40	2.5	3.1	5.8	5.8	11.8	24.0	44.0
	60	3.8	6.6	11.6	13.4	17.8	36.0	67.0
	80	5.0	1.6	3.0	3.2	4.8	9.7	18.3
2 1/2	30	1.9	0.8	1.4	2.2	4.4	8.8	16.6
	40	2.5	1.3	2.5	3.0	5.8	11.8	22.2
	60	3.8	2.7	5.1	5.5	8.8	17.8	34.0
	80	5.0	4.7	8.3	9.7	11.8	24.0	44.0
	100	6.3	7.1	12.2	14.1	14.8	29.0	55.0
3	60	3.8	0.9	1.8	1.8	3.7	7.3	13.8
	100	6.3	2.4	4.4	5.1	6.2	12.1	23.0
	125	7.9	3.6	6.5	7.8	8.1	15.3	29.0
	150	9.5	5.1	9.2	10.4	11.5	18.4	35.0
	175	11.0	6.9	11.7	13.8	15.8	21.4	40.0
	200	12.6	8.9	15.0	17.8	20.3	25.0	46.0
4	80	5.0	0.4	0.8	0.8	1.7	3.3	6.2
	100	6.3	0.6	1.2	1.3	2.1	4.1	7.8
	125	7.9	0.9	1.8	2.1	2.6	5.2	9.8

	150	9.5	1.3	2.4	2.9	3.1	6.2	11.5
	175	11.0	1.8	3.2	4.0	4.0	7.4	13.7
	200	12.6	2.3	4.2	5.1	5.1	8.3	15.5
	250	15.8	3.5	6.0	7.4	8.0	10.2	19.4
6	125	7.9	0.1	0.3	0.3	0.52	1.0	1.9
	150	9.5	0.2	0.3	0.4	0.6	1.2	2.3
	175	11.0	0.2	0.4	0.5	0.7	1.4	2.6
	200	12.6	0.3	0.6	0.7	0.8	1.6	3.0
	250	15.8	0.5	0.8	1.0	1.0	2.1	3.7
	300	18.9	1.1	8.5	10.0	11.6	12.4	23.0
8	400	25.2	1.1	1.9	2.3	2.8	3.2	6.0
	250	15.8	0.1	0.2	0.3	0.4	0.7	1.2
	300	18.9	0.3	1.2	1.4	1.5	2.5	4.6
	400	25.2	0.3	0.5	0.6	0.7	1.1	2.0
10	300	18.9	0.1	0.3	0.4	0.4	0.8	1.5
	400	25.2	0.1	0.2	0.2	0.2	0.4	0.8

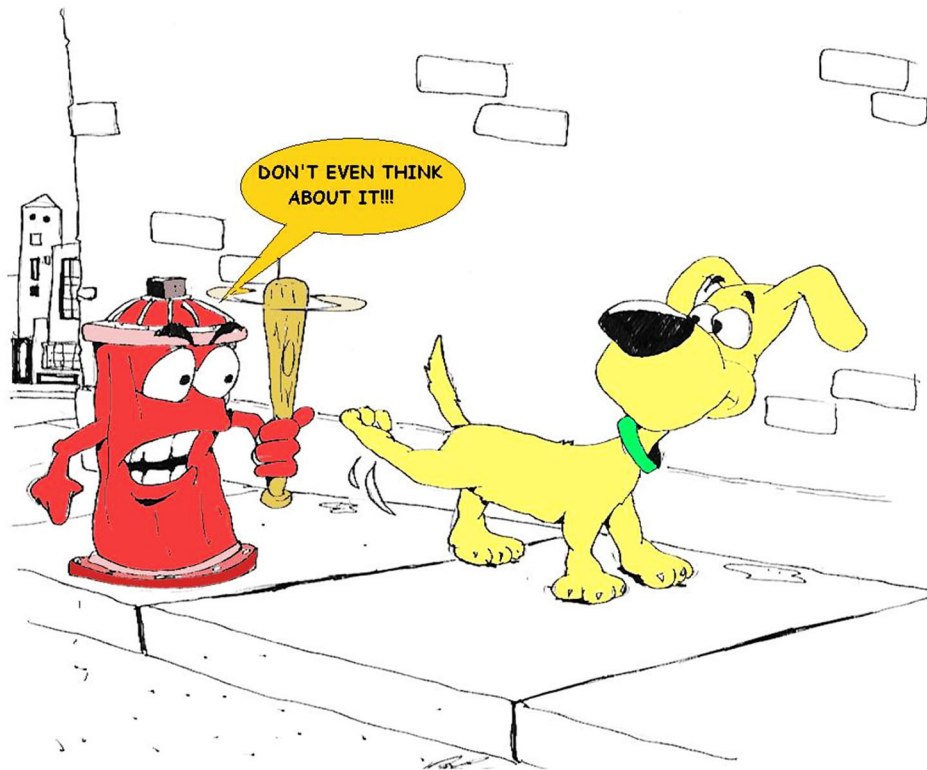

Hazen-Williams Coefficients

Hazen-Williams factor for some common piping materials. Hazen-Williams coefficients are used in the Hazen-Williams equation for friction loss calculation in ducts and pipes. Coefficients for some common materials used in ducts and pipes can be found in the table below:

Material	Hazen-Williams Coefficient - C -
Asbestos Cement	140
Brass	130 - 140
Brick sewer	100
Cast-Iron - new unlined (CIP)	130
Cast-Iron 10 years old	107 - 113
Cast-Iron 20 years old	89 - 100
Cast-Iron 30 years old	75 - 90
Cast-Iron 40 years old	64-83
Cast-Iron, asphalt coated	100
Cast-Iron, cement lined	140
Cast-Iron, bituminous lined	140
Cast-Iron, wrought plain	100
Concrete	100 - 140
Copper or Brass	130 - 140
Ductile Iron Pipe (DIP)	140
Fiber	140
Galvanized iron	120
Glass	130
Lead	130 - 140
Plastic	130 - 150
Polyethylene, PE, PEH	150
PVC, CPVC	150
Smooth Pipes	140
Steel new unlined	140 - 150
Steel	
Steel, welded and seamless	100
Steel, interior riveted, no projecting rivets	100
Steel, projecting girth rivets	100
Steel, vitrified, spiral-riveted	90 - 100
Steel, corrugated	60
Tin	130
Vitrified Clays	110
Wood Stave	110 - 120

Pressure Head

A pressure difference of 5 psi (lbf/in²) is equivalent to

$$5 \text{ (lbf/in}^2\text{)} \cdot 12 \text{ (in/ft)} \cdot 12 \text{ (in/ft)} / 62.4 \text{ (lb/ft}^3\text{)} = \underline{11.6 \text{ ft of water}}$$

$$5 \text{ (lbf/in}^2\text{)} \cdot 12 \text{ (in/ft)} \cdot 12 \text{ (in/ft)} / 847 \text{ (lb/ft}^3\text{)} = \underline{0.85 \text{ ft of mercury}}$$

When specific weight of water is 62.4 (lb/ft³) and specific weight of mercury is 847 (lb/ft³).

Heads at different velocities can be taken from the table below:

Velocity (ft/sec)	Head Water (ft)
0.5	0.004
1.0	0.016
1.5	0.035
2.0	0.062
2.5	0.097
3.0	0.140
3.5	0.190
4.0	0.248
4.5	0.314
5.0	0.389
5.5	0.470
6.0	0.560
6.5	0.657
7.0	0.762
7.5	0.875
8.0	0.995
8.5	1.123
9.0	1.259
9.5	1.403
10.0	1.555
11.0	1.881
12.0	2.239
13.0	2.627
14.0	3.047
15.0	3.498
16.0	3.980
17.0	4.493
18.0	5.037
19.0	5.613
20.0	6.219
21.0	6.856
22.0	7.525

1 ft (foot) = 0.3048 m = 12 in = 0.3333 yd

Thermal Properties of Water

Temperature - t - (°C)	Absolute pressure - p - (kN/m ²)	Density - ρ - (kg/m ³)	Specific volume - v - (m ³ /kgx10 ⁻³)	Specific Heat - c_p - (kJ/kgK)	Specific entropy - e - (kJ/kgK)
0	0.6	1000	100	4.217	0
5	0.9	1000	100	4.204	0.075
10	1.2	1000	100	4.193	0.150
15	1.7	999	100	4.186	0.223
20	2.3	998	100	4.182	0.296
25	3.2	997	100	4.181	0.367
30	4.3	996	100	4.179	0.438
35	5.6	994	101	4.178	0.505
40	7.7	991	101	4.179	0.581
45	9.6	990	101	4.181	0.637
50	12.5	988	101	4.182	0.707
55	15.7	986	101	4.183	0.767
60	20.0	980	102	4.185	0.832
65	25.0	979	102	4.188	0.893
70	31.3	978	102	4.190	0.966
75	38.6	975	103	4.194	1.016
80	47.5	971	103	4.197	1.076
85	57.8	969	103	4.203	1.134
90	70.0	962	104	4.205	1.192
95	84.5	962	104	4.213	1.250
100	101.33	962	104	4.216	1.307
105	121	955	105	4.226	1.382
110	143	951	105	4.233	1.418
115	169	947	106	4.240	1.473
120	199	943	106	4.240	1.527
125	228	939	106	4.254	1.565
130	270	935	107	4.270	1.635
135	313	931	107	4.280	1.687
140	361	926	108	4.290	1.739
145	416	922	108	4.300	1.790
150	477	918	109	4.310	1.842
155	543	912	110	4.335	1.892
160	618	907	110	4.350	1.942
165	701	902	111	4.364	1.992
170	792	897	111	4.380	2.041
175	890	893	112	4.389	2.090
180	1000	887	113	4.420	2.138

185	1120	882	113	4.444	2.187
190	1260	876	114	4.460	2.236
195	1400	870	115	4.404	2.282
200	1550	863	116	4.497	2.329
220					
225	2550	834	120	4.648	2.569
240					
250	3990	800	125	4.867	2.797
260					
275	5950	756	132	5.202	3.022
300	8600	714	140	5.769	3.256
325	12130	654	153	6.861	3.501
350	16540	575	174	10.10	3.781
360	18680	526	190	14.60	3.921



Viscosity Converting Chart

The viscosity of a fluid is its resistance to shear or flow, and is a measure of the fluid's adhesive/cohesive or frictional properties. This arises because of the internal molecular friction within the fluid producing the frictional drag effect. There are two related measures of fluid viscosity which are known as **dynamic** and **kinematic** viscosity.

Dynamic viscosity is also termed "**absolute viscosity**" and is the tangential force per unit area required to move one horizontal plane with respect to the other at unit velocity when maintained a unit distance apart by the fluid.

Centipoise (CPS) Millipascal (mPas)	Poise (P)	Centistokes (cSt)	Stokes (S)	Saybolt Seconds Universal (SSU)
1	0.01	1	0.01	31
2	0.02	2	0.02	34
4	0.04	4	0.04	38
7	0.07	7	0.07	47
10	0.1	10	0.1	60
15	0.15	15	0.15	80
20	0.2	20	0.2	100
25	0.24	25	0.24	130
30	0.3	30	0.3	160
40	0.4	40	0.4	210
50	0.5	50	0.5	260
60	0.6	60	0.6	320
70	0.7	70	0.7	370
80	0.8	80	0.8	430
90	0.9	90	0.9	480
100	1	100	1	530
120	1.2	120	1.2	580
140	1.4	140	1.4	690
160	1.6	160	1.6	790
180	1.8	180	1.8	900
200	2	200	2	1000
220	2.2	220	2.2	1100
240	2.4	240	2.4	1200
260	2.6	260	2.6	1280
280	2.8	280	2.8	1380
300	3	300	3	1475
320	3.2	320	3.2	1530

340	3.4	340	3.4	1630
360	3.6	360	3.6	1730
380	3.8	380	3.8	1850
400	4	400	4	1950
420	4.2	420	4.2	2050
440	4.4	440	4.4	2160
460	4.6	460	4.6	2270
480	4.8	480	4.8	2380
500	5	500	5	2480
550	5.5	550	5.5	2660
600	6	600	6	2900
700	7	700	7	3380
800	8	800	8	3880
900	9	900	9	4300
1000	10	1000	10	4600
1100	11	1100	11	5200
1200	12	1200	12	5620
1300	13	1300	13	6100
1400	14	1400	14	6480
1500	15	1500	15	7000
1600	16	1600	16	7500
1700	17	1700	17	8000
1800	18	1800	18	8500
1900	19	1900	19	9000
2000	20	2000	20	9400
2100	21	2100	21	9850
2200	22	2200	22	10300
2300	23	2300	23	10750
2400	24	2400	24	11200

Various Flow Section Channels and their Geometric

Relationships: Area, wetted perimeter and hydraulic diameter for some common geometric sections like

- rectangular channels
- trapezoidal channels
- triangular channels
- circular channels.

Rectangular Channel

Flow Area

Flow area of a rectangular channel can be expressed as

$$A = b h \quad (1)$$

where

A = flow area (m^2 , in^2)

b = width of channel (m , in)

h = height of flow (m , in)

Wetted Perimeter

Wetted perimeter of a rectangular channel can be expressed as

$$P = b + 2 h \quad (1b)$$

where

P = wetted perimeter (m , in)

Hydraulic Radius

Hydraulic radius of a rectangular channel can be expressed as

$$R_h = b h / (b + 2 h) \quad (1c)$$

where

R_h = hydraulic radius (m , in)

Trapezoidal Channel

Flow Area

Flow area of a trapezoidal channel can be expressed as

$$A = (a + z h) h \quad (2)$$

where

z = see figure above (m , in)

Wetted Perimeter

Wetted perimeter of a trapezoidal channel can be expressed as

$$P = a + 2 h (1 + z^2)^{1/2} \quad (2b)$$

Hydraulic Radius

Hydraulic radius of a trapezoidal channel can be expressed as

$$R_h = (a + z h) h / a + 2 h (1 + z^2)^{1/2} \quad (2c)$$

Triangular Channel

Flow Area

Flow area of a triangular channel can be expressed as

$$A = z h^2 \quad (3)$$

where

z = see figure above (m, in)

Wetted Perimeter

Wetted perimeter of a triangular channel can be expressed as

$$P = 2 h (1 + z^2)^{1/2} \quad (3b)$$

Hydraulic Radius

Hydraulic radius of a triangular channel can be expressed as

$$R_h = z h / 2 (1 + z^2)^{1/2} \quad (3c)$$

Circular Channel

Flow Area

Flow area of a circular channel can be expressed as

$$A = D^2/4 (\alpha - \sin(2 \alpha)/2) \quad (4)$$

where

D = diameter of channel

$\alpha = \cos^{-1}(1 - h/r)$

Wetted Perimeter

Wetted perimeter of a circular channel can be expressed as

$$P = \alpha D \quad (4b)$$

Hydraulic Radius

Hydraulic radius of a circular channel can be expressed as

$$R_h = D/8 [1 - \sin(2 \alpha) / (2 \alpha)] \quad (4c)$$

Velocity Head: Velocity head can be expressed as

$$h = v^2/2g \quad (1)$$

where

v = velocity (ft, m)

g = acceleration of gravity (32.174 ft/s², 9.81 m/s²)

Heads at different velocities can be taken from the table below:

Velocity - v - (ft/sec)	Velocity Head - $v^2/2g$ - (ft Water)
0.5	0.004
1.0	0.016
1.5	0.035
2.0	0.062
2.5	0.097
3.0	0.140
3.5	0.190
4.0	0.248
4.5	0.314
5.0	0.389
5.5	0.470
6.0	0.560
6.5	0.657
7.0	0.762
7.5	0.875
8.0	0.995
8.5	1.123
9.0	1.259
9.5	1.403
10.0	1.555
11.0	1.881
12.0	2.239
13.0	2.627
14.0	3.047
15.0	3.498
16.0	3.980
17.0	4.493
18.0	5.037
19.0	5.613
20.0	6.219
21.0	6.856
22.0	7.525

Some Commonly used Thermal Properties for Water

- Density at 4 °C - 1,000 kg/m³, 62.43 Lbs./Cu.Ft, 8.33 Lbs./Gal., 0.1337 Cu.Ft./Gal.
- Freezing temperature - 0 °C
- Boiling temperature - 100 °C
- Latent heat of melting - 334 kJ/kg
- Latent heat of evaporation - 2,270 kJ/kg
- Critical temperature - 380 - 386 °C
- Critical pressure - 23.520 kN/m²
- Specific heat capacity water - 4.187 kJ/kgK
- Specific heat capacity ice - 2.108 kJ/kgK
- Specific heat capacity water vapor - 1.996 kJ/kgK
- Thermal expansion from 4 °C to 100 °C - 4.2×10^{-2}
- Bulk modulus elasticity - 2,068,500 kN/m²

Reynolds Number

Turbulent or laminar flow is determined by the dimensionless **Reynolds Number**.

The Reynolds number is important in analyzing any type of flow when there is substantial velocity gradient (i.e., shear.) It indicates the relative significance of the viscous effect compared to the inertia effect. The Reynolds number is proportional to inertial force divided by viscous force.

A definition of the Reynolds' Number.

The flow is

- **laminar** if $Re < 2300$
- **transient** if $2300 < Re < 4000$
- **turbulent** if $4000 < Re$

The table below shows Reynolds Number for one liter of water flowing through pipes of different dimensions:

		Pipe Size								
(inches)	1	1 ?	2	3	4	6	8	10	12	18
(mm)	25	40	50	75	100	150	200	250	300	450
Reynolds number with one (1) liter/min	835	550	420	280	210	140	105	85	70	46
Reynolds number with one (1) gal/min	3800	2500	1900	1270	950	630	475	380	320	210

Linear Motion Formulas

Velocity can be expressed as (velocity = constant):

$$v = s / t \text{ (1a)}$$

where

v = velocity (m/s, ft/s)

s = linear displacement (m, ft)

t = time (s)

Velocity can be expressed as (acceleration = constant):

$$v = V_0 + a t \text{ (1b)}$$

where

V_0 = linear velocity at time zero (m/s, ft/s)

Linear displacement can be expressed as (acceleration = constant):

$$s = V_0 t + 1/2 a t^2 \text{ (1c)}$$

Combining 1a and 1c to express velocity

$$v = (V_0^2 + 2 a s)^{1/2} \text{ (1d)}$$

Velocity can be expressed as (velocity variable)

$$v = ds / dt \text{ (1f)}$$

where

ds = change of displacement (m, ft)

dt = change in time (s)

Acceleration can be expressed as

$$a = dv / dt \text{ (1g)}$$

where

dv = change in velocity (m/s, ft/s)

Water - Dynamic and Kinematic Viscosity

Dynamic and Kinematic Viscosity of Water in Imperial Units (BG units):

Temperature - t - (°F)	Dynamic Viscosity - μ - 10^{-5} (lb.s/ft ²)	Kinematic Viscosity - ν - 10^{-5} (ft ² /s)
32	3.732	1.924
40	3.228	1.664
50	2.730	1.407
60	2.344	1.210
70	2.034	1.052
80	1.791	0.926
90	1.500	0.823
100	1.423	0.738
120	1.164	0.607
140	0.974	0.511
160	0.832	0.439
180	0.721	0.383
200	0.634	0.339
212	0.589	0.317

Dynamic and Kinematic Viscosity of Water in SI Units:

Temperature - t - (°C)	Dynamic Viscosity - μ - 10^{-3} (N.s/m ²)	Kinematic Viscosity - ν - 10^{-6} (m ² /s)
0	1.787	1.787
5	1.519	1.519
10	1.307	1.307
20	1.002	1.004
30	0.798	0.801
40	0.653	0.658
50	0.547	0.553
60	0.467	0.475
70	0.404	0.413
80	0.355	0.365
90	0.315	0.326
100	0.282	0.294

Water and Speed of Sound

Speed of sound in water at temperatures between 32 - 212°F (0-100°C) - imperial and SI units. Speed of Sound in Water - in imperial units (BG units)

Temperature - <i>t</i> - (°F)	Speed of Sound - <i>c</i> - (ft/s)
32	4,603
40	4,672
50	4,748
60	4,814
70	4,871
80	4,919
90	4,960
100	4,995
120	5,049
140	5,091
160	5,101
180	5,095
200	5,089
212	5,062

Speed of Sound in Water - in SI units

Temperature - <i>t</i> - (°C)	Speed of Sound - <i>c</i> - (m/s)
0	1,403
5	1,427
10	1,447
20	1,481
30	1,507
40	1,526
50	1,541
60	1,552
70	1,555
80	1,555
90	1,550
100	1,543

Math Conversion Factors and Practical Exercise Section

1 PSI = 2.31 Feet of Water
 1 Foot of Water = .433 PSI
 1.13 Feet of Water = 1 Inch of Mercury
 454 Grams = 1 Pound
 2.54 CM = Inch
 1 Gallon of Water = 8.34 Pounds
 1 mg/L = 1 PPM
 17.1 mg/L = 1 Grain/Gallon
 1% = 10,000 mg/L
 694 Gallons per Minute = MGD
 1.55 Cubic Feet per Second = 1 MGD
 60 Seconds = 1 Minute
 1440 Minutes = 1 Day
 .746 kW = 1 Horsepower

LENGTH

12 Inches = 1 Foot
 3 Feet = 1 Yard
 5280 Feet = 1 Mile

AREA

144 Square Inches = 1 Square Foot
 43,560 Square Feet = 1 Acre

VOLUME

1000 Milliliters = 1 Liter
 3.785 Liters = 1 Gallon
 231 Cubic Inches = 1 Gallon
 7.48 Gallons = 1 Cubic Foot of Water
 62.38 Pounds = 1 Cubic Foot of Water

Dimensions

SQUARE: Area (sq. ft.) = Length X Width
 Volume (cu. ft.) = Length (ft) X Width (ft) X Height (ft)

CIRCLE: Area (sq.ft) = 3.14 X Radius (ft) X Radius (ft)

CYLINDER: Volume (Cu. ft) = 3.14 X Radius (ft) X Radius (ft) X Depth (ft)

PIPE VOLUME: .785 X Diameter ² X Length = ? To obtain gallons multiply by 7.48

SPHERE: $\frac{(3.14) (\text{Diameter})^3}{(6)}$ Circumference = 3.14 X Diameter

General Conversions

Flowrate

Multiply	→	to get
to get	←	Divide
cc/min	1	mL/min
cfm (ft ³ /min)	28.31	L/min
cfm (ft ³ /min)	1.699	m ³ /hr
cfh (ft ³ /hr)	472	mL/min
cfh (ft ³ /hr)	0.125	GPM
GPH	63.1	mL/min
GPH	0.134	cfh
GPM	0.227	m ³ /hr
GPM	3.785	L/min

POUNDS PER DAY = Concentration (mg/L) X Flow (MG) X 8.34
AKA Solids Applied Formula = Flow X Dose X 8.34

TEMPERATURE: $^{\circ}\text{F} = (^{\circ}\text{C} \times 9/5) + 32$ $9/5 = 1.8$
 $^{\circ}\text{C} = (^{\circ}\text{F} - 32) \times 5/9$ $5/9 = .555$

CONCENTRATION: Conc. (A) X Volume (A) = Conc. (B) X Volume (B)

FLOW RATE (Q): $Q = A \times V$ (**Quantity** = **Area** X **Velocity**)

FLOW RATE (gpm): Flow Rate (gpm) = $\frac{2.83 (\text{Diameter, in})^2 (\text{Distance, in})}{\text{Height, in}}$

VELOCITY = $\frac{\text{Distance (ft)}}{\text{Time (Sec)}}$

N = Manning's Coefficient of Roughness

R = Hydraulic Radius (ft.)

S = Slope of Sewer (ft/ft.)

HYDRAULIC RADIUS (ft) = $\frac{\text{Cross Sectional Area of Flow (ft)}}{\text{Wetted pipe Perimeter (ft)}}$

MIXTURE STRENGTH (%) = $\frac{(\text{Volume 1, gal}) (\text{Strength 1, \%}) + (\text{Volume 2, gal}) (\text{Strength 2, \%})}{(\text{Volume 1, gal}) + (\text{Volume 2, gal})}$

INJURY FREQUENCY RATE = $\frac{(\text{Number of Injuries}) 1,000,000}{\text{Number of hours worked per year}}$

HYDRAULIC RADIUS (ft) = $\frac{\text{Flow Area (ft. }^2)}{\text{Wetted Perimeter (ft.)}}$

Volume in Cubic Feet

Cube Formula

$$V = (L) (W) (D)$$

$$\text{Volume} = \text{Length} \times \text{Width} \times \text{Depth}$$

Cylinder Formula

$$V = (.785) (D^2) (d)$$

Build it, Fill it and Dose it.

- 1. Convert 10 cubic feet to gallons of water.**

There is 7.48 gallons in one cubic foot.

- 2. A tank weighs 800 pounds, how many gallons are in the tank?**

- 3. Convert a flow rate of 953 gallons per minute to million gallons per day.**

There is 1440 minutes in a day.

- 4. Convert a flow rate of 610 gallons per minute to millions of gallons per day.**

- 5. Convert a flow of 550 gallons per minute to gallons per second.**

- 6. Now, convert this number to liters per second.**

7. A tank is 6' X 15' x 7' and can hold a maximum of _____ gallons of water.
 $V = (L) (W) (D) \times 7.48 =$

8. A tank is 25' X 75' X 10' what is the volume of water in gallons?
 $V = (L) (W) (D) \times 7.48 =$

9. In Liters?
 $V = (L) (W) (D) \times 7.48 =$ _____ $\times 3.785$

10. A tank holds 67,320 gallons of water. The length is 60' and the width is 15'.
How deep is the tank?

Gallons _____ $\div 7.48 =$ _____ $60 \times 15 =$

11. The diameter of a tank is 60' and the depth is 25'. How many gallons does it hold?

Cylinder Formula
 $V = (.785) (D^2) (d)$

$.785 \times 60' \times 60' \times 25' \times 7.48 =$

Cubic Feet Information

There is no universally agreed symbol but the following are used:

cubic feet, cubic foot, cubic ft

cu ft, cu feet, cu foot

ft³, feet³, foot³

feet³, foot³, ft³

feet/-3, foot/-3, ft/-3

Water Treatment Production Math Numbering System

In water treatment, we express our production numbers in Million Gallon numbers.

Example 2,000,000 or 2 million gallons would be expressed as 2 MG or 2 MGD.

Hints. A million has six zeros, you can always divide your final number by 1,000,000 or move the decimal point to the left six places. Example 528,462 would be expressed .56 MGD.

12. The diameter of a tank is 15 Centimeters or cm and the depth is 25 cm, what is the volume in liters?

2.54cm = 1 inch, 12 inches = 1 foot

15 cm ÷ 2.54 cm ÷ 12 inches = .492 feet

$$.785 \times .492' \times .492' \times \underline{\hspace{1cm}}' = \underline{\hspace{1cm}} \times 7.48 = \underline{\hspace{1cm}} \times 3.785 \text{ L} =$$

Percentage and Fractions

Let's look again at the sequence of numbers 1000, 100, 10, 1, and continue the pattern to get new terms by dividing previous terms by 10:

$$\begin{aligned} .1 &= 1/10 \\ .01 &= 1/100 \\ .001 &= 1/1000 \end{aligned}$$

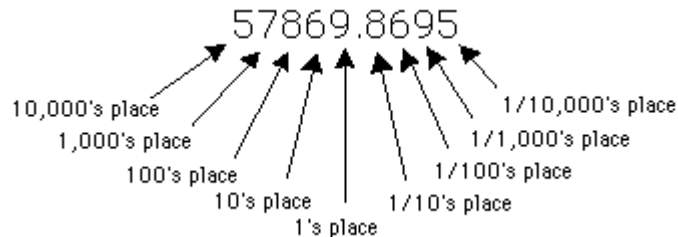

So just as the digits to the left of the decimal represent 1's, 10's, 100's, and so forth, digits to the right of the decimal point represent 1/10's, 1/100's, 1/1000's, and so forth.

Let's express 5% as a decimal. $5 \div 100 = 0.05$ or you can move the decimal point to the left two places.

Changing a fraction to a decimal:

Divide the numerator by the denominator

A. $5/10$ (five tenths) = five divided by ten:

$$\begin{array}{r} .5 \\ \hline 10 \overline{) 5.0} \\ \underline{50} \\ \hline \end{array}$$

So $5/10$ (five tenths) = $.5$ (five tenths).

B. How about 1/2 (one half) or 1 divided by 2 ?

$$\begin{array}{r} .5 \\ \text{-----} \\ 2 \) \ 1.0 \\ \quad 1 \ 0 \\ \text{-----} \end{array}$$

So 1/2 (one half) = .5 (five tenths)

Notice that equivalent fractions convert to the same decimal representation.

8/12 is a good example. $8 \div 12 = .66666666$ or rounded off to .667

How about 6/12 or 6 inches? .5 or half a foot

Flow and Velocity

This depends on measuring the average velocity of flow and the cross-sectional area of the channel and calculating the flow from:

$$Q(\text{m}^3/\text{s}) = A(\text{m}^2) \times V(\text{m}/\text{s})$$

Or

$$Q = A \times V$$

Q CFM = Cubic Ft, Inches, Yards of time, Sec, Min, Hrs, Days

A = Area, squared Length X Width

V f/m = Inch, Ft, Yards, Per Time, Sec, Min, Ft or Speed

13. A channel is 3 feet wide and has water flowing to a depth of 2.5 feet. If the velocity through the channel is 2 fps or feet per second, what is the cfs flow rate through the channel?

$$Q = A \times V$$

Q = 7.5 sq. ft. X 2 fps What is Q?

$$A = 3' \times 2.5' = 7.5$$

$$V = 2 \text{ fps}$$

14. A channel is 40 inches wide and has water flowing to a depth of 1.5 ft. If the velocity of the water is 2.3 fps, what is the cfs flow in the channel? Q = A X V

First we must convert 40 inches to feet.

$$40 \div 12'' = 3.333 \text{ feet}$$

$$A = 3.333' \times 1.5' = 4.999 \text{ or round up to } 5$$

$$V = 2.3 \text{ fps}$$

We can round this answer up.

15. The flow through a 6-inch diameter pipe is moving at a velocity of 3 ft/sec. What is the cfs flow rate through the pipeline?

$$Q =$$

$$A = .785 \times .5' \times .5' =$$

$$V = 3 \text{ fps}$$

16. An 8 inch diameter pipe has water flowing at a velocity of 3.4 fps. What is the gpm flow rate through the pipe?

$$Q = \underline{\hspace{2cm}} \text{ cfs} \times 60 \text{ sec/min} \times 7.48 = \underline{\hspace{2cm}} \text{ gpm}$$

$$A = .785 \times .667' \times .667'$$

$$V = 3.4 \text{ fps}$$

17. A 6 inch diameter pipe delivers 280 gpm. What is the velocity of flow in the pipe in ft/sec?

$$\text{Take the water out of the pipe. } 280 \text{ gpm} \div 7.48 \div 60 \text{ sec/min} = \underline{\hspace{2cm}} \text{ cfs}$$

$$Q =$$

$$A = .785 \times .5' \times .5' =$$

$$V =$$

18. A new section of 12-inch diameter pipe is to be disinfected before it is placed in service. If the length is 2000 feet, how many gallons of 5% NaOCl will be need for a dosage of 200 mg/L?

Cylinder Formula

$$V = (.785) (D^2) (L)$$

$$.785 \times 1' \times 1' \times 2000' = \underline{\hspace{2cm}} \text{ cuft} \times 7.48 = \underline{\hspace{2cm}} \div 1,000,000 = \underline{\hspace{2cm}} \text{ MG}$$

Pounds per day formula = Flow (MGD) X Dose (mg/L) X 8.34 lbs/gal if 100% concentrate. If not, divide the lbs/day by the given %

$$0.0117436 \text{ MG} \times 200 \text{ mg/L} \times 8.34 = \underline{\hspace{2cm}} \text{ lbs/day} \div .05 =$$

19. A section of 6 inch diameter pipe is to be filled with water. The length of the pipe is 1320 feet long. How many kilograms of chlorine will be needed for a chlorine dose of 3 mg/L?

$$.785 \times .5' \times .5' \times 1320' \times 7.48 = \underline{\hspace{2cm}} \text{ Make it MGD}$$

Pounds per day formula = Flow X Dose X 8.34 X 45.4 Grams per pound

20. Determine the chlorinator setting in pounds per 24 hour period to treat a flow of 3.4 MGD with a chlorine dose of 3.35 mg/L?

Pounds per day formula = Flow (MGD) X Dose (mg/L) X 8.34 lbs/gal

21. To correct an odor problem, you use chlorine continuously at a dosage of 15 mg/L and a flow rate of 85 GPM. Approximately how much will odor control cost annually if chlorine is \$0.17 per pound?

$$85 \text{ gpm} \times 1440 \text{ min/day} = \text{_____} \text{ gpd} \div 1,000,000 = \text{_____} \text{ MGD}$$

$$\text{_____} \text{ MGD} \times 15 \text{ mg/L} \times 8.34 \text{ lbs/gal} \times \$0.17 \text{ per pound} \times 365 \text{ days/year} =$$

22. A wet well measures 8 feet by 10 feet and 3 feet in depth between the high and low levels. A pump empties the wet well between the high and low levels 9 times per hour, 24 hours a day. Neglecting inflow during the pumping cycle, calculate the flow into the pump station in millions of gallons per day (MGD).

Build it, fill it and do what it says, hint: $X 9 X 24$

Crazy Math Section

The metric system is known for its simplicity. All units of measurement in the metric system are based on decimals—that is, units that increase or decrease by multiples of ten. A series of Greek decimal prefixes is used to express units of ten or greater; a similar series of Latin decimal prefixes is used to express fractions. For example, *deca* equals ten, *hecto* equals one hundred, *kilo* equals one thousand, *mega* equals one million, *giga* equals one billion, and *tera* equals one trillion. For units below one, *deci* equals one-tenth, *centi* equals one-hundredth, *milli* equals one-thousandth, *micro* equals one-millionth, *nano* equals one-billionth, and *pico* equals one-trillionth.

23. How many grams equal 3,500 mg?

Just simply divide by 1,000.

Remember this “*King Henry died by drinking Chocolate Milk*”.

Kilo- Heca- Deca- Centi - Mili

Temperature

There are two main temperature scales. The **Fahrenheit Scale** (used in the US), and the **Celsius Scale** (part of the Metric System, used in most other Countries)

They both measure the same thing (temperature!), just using different numbers.

- If you freeze water, it measures 0° in Celsius, but 32° in Fahrenheit
- If you boil water, it measures 100° in Celsius, but 212° in Fahrenheit
- The difference between freezing and boiling is 100° in Celsius, but 180° in Fahrenheit.

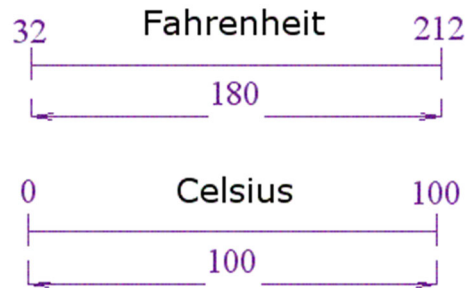

Conversion Method

Looking at the diagram, notice:

- The scales start at a different number (32 vs 0), so we will need to add or subtract 32
- The scales rise at a different rate (180 vs 100), so we will also need to multiply

And this is how it works out:

To convert from Celsius to Fahrenheit, first multiply by 180/100, then add 32

To convert from Fahrenheit to Celsius, first subtract 32, then multiply by 100/180

Note: 180/100 can be simplified to **9/5**, and likewise 100/180=**5/9**.

$$^{\circ}\text{F} = (^{\circ}\text{C} \times 9/5) + 32 \quad 9/5 = 1.8$$

$$^{\circ}\text{C} = (^{\circ}\text{F} - 32) \times 5/9 \quad 5/9 = .555$$

24. Convert 20 degrees Celsius to degrees Fahrenheit.

$$20^{\circ} \times 1.8 + 32 = \text{F}$$

25. Convert 4 degrees Celsius to degrees Fahrenheit.

Water Treatment Filters

26. A 19 foot wide by 31 foot long rapid sand filter treats a flow of 2,050 gallons per minute. Calculate the filtration rate in gallons per minute per square foot of filter area.

GPM ÷ Square Feet

27. A 26 foot wide by 36 foot wide long rapid sand filter treats a flow of 2,500 gallons per minute. Calculate the filtration rate in gallons per minute per square foot of filter area.

Chemical Dose

28. A pond has a surface area of 51,500 square feet and the desired dose of a chemical is 6.5 lbs per acre. How many pounds of the chemical will be needed?

43,560 Square feet in an acre

$$51,500 \div 43,560 = \underline{\hspace{2cm}} \times 6.5 =$$

29. A pond having a volume of 6.85 acre feet equals how many millions of gallons?

Q=AV Review

30. An 8 inch diameter pipe has water flowing at a velocity of 3.4 fps. What is the GPM flow rate through the pipe?

$$Q = 1.18 \text{ CFS} \times 60 \text{ Seconds} \times 7.48 \text{ GAL/CU.FT} = 532 \text{ GPM}$$

$$A = .785 \times .667 \times .667 \times 1 = .349 \text{ Sq. Ft.}$$

$$V = 3.4 \text{ Feet per second}$$

31. A 6 inch diameter pipe delivers 280 GPM. What is the velocity of flow in the pipe in Ft/Sec?

$$280 \text{ GPM} \div 60 \text{ seconds in a minute} \div 7.48 \text{ gallons in a cu. ft.} = .623 \text{ CFS}$$

$$Q = .623$$

$$A = .785 \times .5 \times .5 = .196 \text{ Sq. Ft.}$$

$$V = 3.17 \text{ Ft/Second}$$

32. Calculate the total dosage in pounds of a chemical. Assume the sewer is completely filled with the concentration. Pipe diameter: 18 inches, Pipe length: 420 feet, Dose: 120 mg/L.

Figure out the volume first.

$$.785 \times 1.5' \times 1.5' \times 420' \times 7.48 = \underline{\hspace{2cm}} \text{ convert to MG}$$

Pounds per day formula = Flow (MGD) X Dose (mg/L) X 8.34 lbs/gal

References

Several Photographs and Reference were provided by
GA Industries, Inc.
WWW. Gaindustries.com
Telephone (724) 776-1020
Fax (724) 776-1254
9025 Marshall Road
Cranberry Township, PA 16066 USA

CLA-VAL

P.O.Box 1325
Newport Beach, CA 92659-0325
Phone: (949) 722-4800 • 1-800-942-6326
Fax: (949) 548-5441
www.cla-val.com
E-mail: claval@cla-val.com
US Regional Offices
WESTERN REGION:
Phone: (951) 687-9145
1-800-247-9090
Fax: (951) 687-9954
E-mail: lvanderk@cla-val.com
SOUTHERN REGION:
Phone: (281) 759-9590
1-800-336-7171
Fax: (281) 759-8938
E-mail: blindsey@cla-val.com
NORTHERN REGION:
Phone: (847) 697-1413
1-800-238-7070
Fax: (847) 697-5549
E-mail: djurs@cla-val.com
EASTERN REGION:
Phone: (703) 721-1923
1-800-451-3030
Fax: (703) 721-1927
E-mail: bmoore@cla-val.com

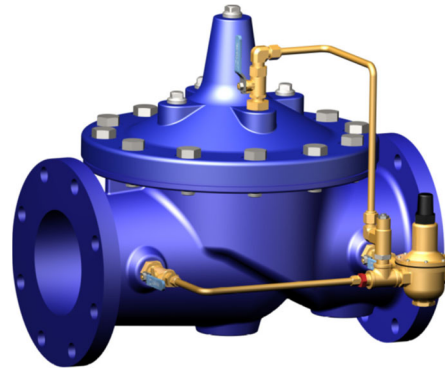
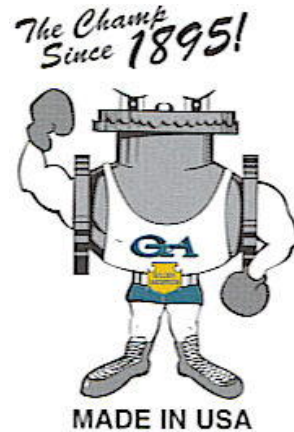

Please call these nice people for further information.



We welcome you to complete the assignment in Microsoft Word. You can easily find the assignment at www.abctlc.com.

Once complete, just simply fax or e-mail the answer key along with the registration page to us and allow two weeks for grading. Once we grade it, we will e-mail a certificate of completion to you.

Call us if you need any help. If you need your certificate back within 48 hours, you may be asked to pay a rush service fee of \$50.00.

You can download the assignment in Microsoft Word from TLC's website under the Assignment Page. www.abctlc.com

You will have 90 days in order to successfully complete this assignment with a score of 70% or better.

If you need any assistance, please contact TLC's Student Services. Once you are finished, please mail, e-mail or fax your answer sheet along with your registration form.