

# BASIC PLUMBING

CONTINUING EDUCATION  
PROFESSIONAL DEVELOPMENT COURSE



 **Technical  
Learning  
College**



## Printing and Saving Instructions

It is recommended that you download this pdf document and assignment to your computer desktop and open it with Adobe Acrobat DC reader.

Adobe Acrobat DC reader is a free computer software program and you can find it at Adobe Acrobat's website.

You can complete the course by viewing the course on your computer or you can print it out. This course booklet does not have the assignment (the test). Please visit our website and download the assignment (the test).

**Printing Instructions:** Once you have purchased the program, we will give you permission to print this document. If you are going to print this document, it was designed to be printed double-sided or duplexed but can be printed single-sided.

*You can obtain a printed version from TLC for an additional \$129.95 plus shipping charges.*

### **Link to Assignment...**

<http://www.ABCTLC.com/downloads/PDF/Plumbing%20Assignment.pdf>

**State Approval Listing Link**, check to see if your State accepts or has pre-approved this course. Not all States are listed. Not all courses are listed. Do not solely trust our list for it may be outdated. It is your sole responsibility to ensure this course is accepted for credit. No refunds.

<http://www.ABCTLC.com/downloads/PDF/CEU%20State%20Approvals.pdf>

*All downloads are electronically tracked and monitored for security purposes.*



**Some States and many employers require the final exam to be proctored.**

**Do not solely depend on TLC's Approval list for it may be outdated.**

Most of our students prefer to do the assignment in Word and e-mail or fax the assignment back to us. We also teach this course in a conventional hands-on class. Call us and schedule a class today.

### ***Responsibility***

*This course contains EPA's federal rule requirements. Please be aware that each state implements drinking water/wastewater/safety regulations that may be more stringent than EPA's or OSHA's regulations. Check with your state environmental agency for more information. You are solely responsible in ensuring that you abide with your jurisdiction or agency's rules and regulations.*

## Contributing Editors

**James L. Six** Received a Bachelor of Science Degree in Civil Engineering from the University of Akron in June of 1976, Registered Professional Engineer in the State of Ohio, Number 45031 (Retired), Class IV Water Supply Operator issued by Ohio EPA, Number WS4-1012914-08, Class II Wastewater Collection System Operator issued by Ohio EPA, Number WC2-1012914-94

**Joseph Camerata** has a BS in Management with honors (magna cum laude). He retired as a Chemist in 2006 having worked in the field of chemical, environmental, and industrial hygiene sampling and analysis for 40 years.

**James Bevan**, Water Quality Inspector S.M.E. Twenty years of experience in the environmental field dealing with all aspects of water regulations on the federal, state, and local levels. Teacher and Proctor in Charge for Backflow Certification Testing at the ASETT Center in Tucson for the past 15 years and possess an Arizona Community College, Special Teaching Certificate in Environmental Studies.

**Dr. Pete Greer** S.M.E., Retired biology instructor, chemistry and biological review.

**Jack White**, Environmental, Health, Safety expert, City of Phoenix. Art Credits.

**Check with your State to see if this course has been accepted.**

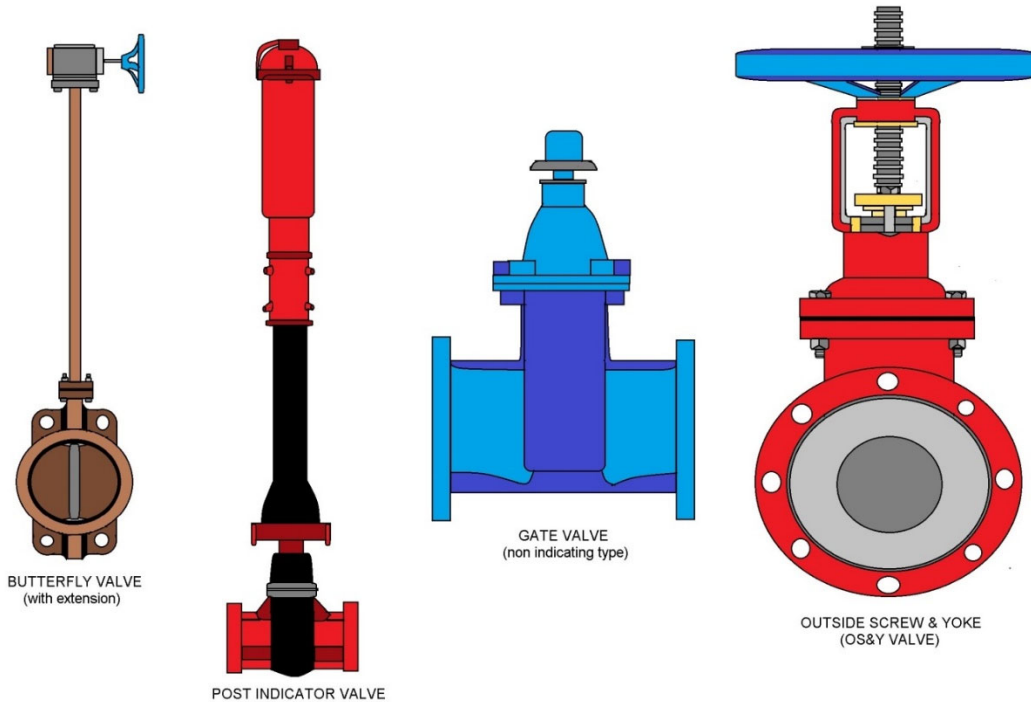

## TYPES OF VALVES

**Basic Plumbing**© www.abctlc.com 7/8/2002 All plastic piping photos are used by permission from Spears MFG. Co, All backflow materials are used by permission from CMB Industries, Inc.



## **Copyright Notice**

1999-2020 Technical Learning College (TLC) No part of this work may be reproduced or distributed in any form or by any means without TLC's prior written approval. Permission has been sought for all images and text where we believe copyright exists and where the copyright holder is traceable and contactable. Other materials including text and artwork are in the public domain or fair use (the state of belonging or being available to the public as a whole, and therefore not subject to copyright.) All material that is not credited or acknowledged or referenced in the rear of this course is the copyright of Technical Learning College. All other unacknowledged references are in the Water/ Wastewater Sampling and Water Chemistry Courses. Most unaccredited photographs have been taken by TLC instructors or TLC students. All written, graphic, photographic or other material is provided for educational information only. We will be pleased to hear from any copyright holder and will make good on your work if any unintentional copyright infringements were made as soon as these issues are brought to the editor's attention. This educational training course and assignment is intended for educational purposes only. Every possible effort was made to ensure that all information provided in this course is accurate. Therefore, Technical Learning College accepts no responsibility or liability whatsoever for the application or misuse of any information included herein.

Requests for acknowledgements or permission to make copies shall be made to the following address: TLC, P.O. Box 3060, Chino Valley, AZ 86323

Information in this document is subject to change without notice. TLC is not liable for errors or omissions appearing in this document.





# Technical Learning College's Scope and Function

Welcome to the Program,

Technical Learning College (TLC) offers affordable continuing education for today's working professionals who need to maintain licenses or certifications. TLC holds several different governmental agency approvals for granting of continuing education credit.

TLC's delivery method of continuing education can include traditional types of classroom lectures and distance-based courses or independent study. TLC's distance based or independent study courses are offered in a print - based distance educational format. We will beat any other training competitor's price for the same CEU material or classroom training.

Our courses are designed to be flexible and for you to finish the material at your convenience. Students can also receive course materials through the mail. The CEU course or e-manual will contain all your lessons, activities and instruction to obtain the assignments. All of TLC's CEU courses allow students to submit assignments using e-mail or fax, or by postal mail. (See the course description for more information.)

Students have direct contact with their instructor—primarily by e-mail or telephone. TLC's CEU courses may use such technologies as the World Wide Web, e-mail, CD-ROMs, videotapes and hard copies. (See the course description.) Make sure you have access to the necessary equipment before enrolling; i.e., printer, Microsoft Word and/or Adobe Acrobat Reader. Some courses may require proctored closed-book exams, depending upon your state or employer requirements.

## **Flexible Learning**

At TLC, there are no scheduled online sessions or passwords you need contend with, nor are you required to participate in learning teams or groups designed for the "typical" younger campus based student. You will work at your own pace, completing assignments in time frames that work best for you. TLC's method of flexible individualized instruction is designed to provide each student the guidance and support needed for successful course completion.

## **Course Structure**

TLC's online courses combine the best of online delivery and traditional university textbooks. You can easily find the course syllabus, course content, assignments, and the post-exam (Assignment). This student-friendly course design allows you the most flexibility in choosing when and where you will study.

## **Classroom of One**

TLC offers you the best of both worlds. You learn on your own terms, on your own time, but you are never on your own. Once enrolled, you will be assigned a personal Student Service Representative who works with you on an individualized basis throughout your program of study. Course specific faculty members (S.M.E.) are assigned at the beginning of each course providing the academic support you need to successfully complete each course. Please call or email us for assistance.

### **Satisfaction Guaranteed**

We have many years of experience, dealing with thousands of students. We assure you, our customer satisfaction is second to none. This is one reason we have taught more than 20,000 students.

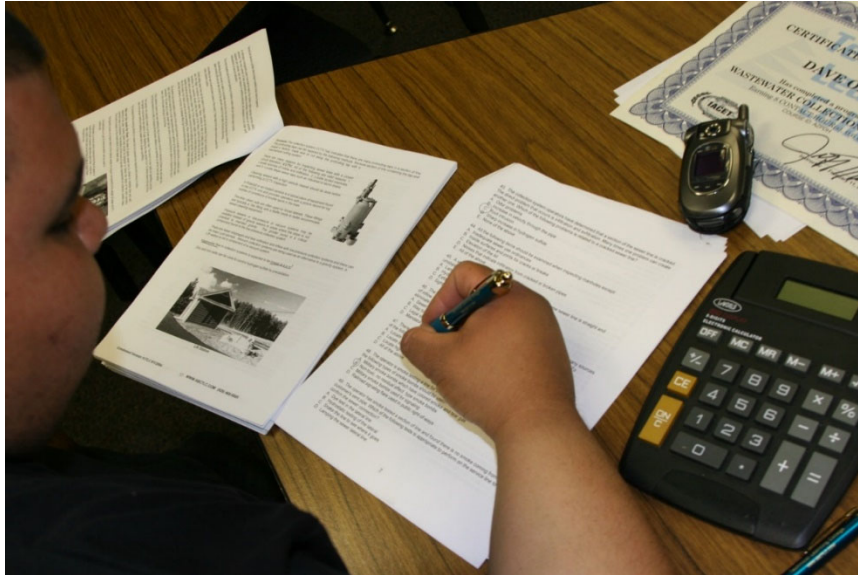

We welcome you to do the electronic version of the assignment and submit the answer key and registration to us either by fax or e-mail. If you need this assignment graded and a certificate of completion within a 48-hour turn around, prepare to pay an additional rush charge of \$50.

**Contact Numbers**  
**Fax (928) 468-0675**  
**Email [Info@tlch2o.com](mailto:Info@tlch2o.com)**  
**Telephone (866) 557-1746**

# Course Description

## Basic Plumbing CEU Training Course

Review of water distribution plumbing and related fundamentals. This course will cover the basics of piping, valves, backflow prevention, water quality and hydraulic fundamentals. You will not need any other materials for this course.

### Audience

Water Distribution, Well Drillers, Pump Installers, Water Treatment Operators, Wastewater Treatment Operators, Wastewater Collection Operators, Industrial Wastewater Operators and General Backflow Assembly Testers, and Plumbers--the target audience for this course is the person interested in working in a water or wastewater treatment or distribution/collection facility, performing basic or light plumbing, wishing to maintain CEUs for a certification license, wanting to learn how to do the job safely and effectively, and/or to meet education needs for promotion.



### Course Procedures for Registration and Support

All of Technical Learning College's correspondence courses have complete registration and support services offered. Delivery of services will include e-mail, web site, telephone, fax and mail support. TLC will attempt immediate and prompt service. When a student registers for a distance or correspondence course, he/she is assigned a start date and an end date. It is the student's responsibility to note dates for assignments and keep up with the course work. All students will be tracked by a unique number assigned to the student.

### Instructions for Written Assignments

The Basic Plumbing CEU Training course will be a Fill-in-the-Blank and True or False type of an exam. TLC will require that the document is typed and preferably e-mailed or faxed to TLC. You can find complete course support on TLC's website under the Assignment Page.

### Feedback Mechanism (Examination Procedures)

Each student will receive a feedback form as part of their study packet. You will be able to find this form in the front of the course assignment or lesson.

### Security and Integrity

All students are required to do their own work. All lesson sheets and final exams are not returned to the student to discourage sharing of answers. Any fraud or deceit and the student will forfeit all fees and the appropriate agency will be notified.

**Grading Criteria**

In order to successfully pass this course, you will need to have 70% or better on the final exam.

**Required Texts**

The *Basic Plumbing* CEU Training course does not require any course materials. Course comes complete.

**Educational Mission**

**The educational mission of TLC is:**

*To provide TLC students with comprehensive and ongoing training in the theory and skills needed for the environmental education field,*

*To provide TLC students with opportunities to apply and understand the theory and skills needed for operator certification,*

*To provide opportunities for TLC students to learn and practice environmental educational skills with members of the community for the purpose of sharing diverse perspectives and experience,*

*To provide a forum in which students can exchange experiences and ideas related to environmental education,*

*To provide a forum for the collection and dissemination of current information related to environmental education, and to maintain an environment that nurtures academic and personal growth.*

## Important Information about this Manual

This manual has been prepared to educate students and operators in general safety awareness of dealing with the often-complex and various water distribution devices, methods, and light plumbing applications. This manual will cover procedures and accepted policies relating to the use of water distribution, backflow protection devices, methods, and light plumbing applications.

It should be noted, however, that the regulation of plumbing and water distribution materials is an ongoing process and subject to change over time. For this reason, a list of resources is provided to assist in obtaining the most up-to-date information on various subjects.

This manual is not a guidance or code document for plumbers or operators. It is not designed to meet the requirements of the United States Environmental Protection Agency (**EPA**), Office of Health and Safety Administration (OSHA) or your local State environmental protection agency, health department, building code or plumbing enforcement agency.

This course manual will provide general water distribution, piping and backflow protection information and should not be used as a basis for plumbing, backflow protection method/device guidance. This document is not a detailed plumbing code manual or a source or remedy for plumbing license or certification.

Technical Learning College or Technical Learning Consultants, Inc. makes no warranty, guarantee or representation as to the absolute correctness or appropriateness of the information in this manual and assumes no responsibility in connection with the implementation of this information. It cannot be assumed that this manual contains all measures and concepts required for specific conditions or circumstances.

This document should be used for educational purposes only and is not considered a legal document.

Individuals who are responsible for plumbing, water distribution systems, and backflow protection should obtain and comply with the most recent federal, state, and local regulations relevant to these sites and are urged to consult with OSHA, Building Authority, the EPA and other appropriate federal, state and local agencies.



# TABLE OF CONTENTS

<b>Chapter 1 - Basic Plumbing</b> .....	<b>15</b>
<b>Chapter 2 - Hydraulic Principles</b> .....	<b>19</b>
Barometric Loop.....	21
Water Pressure.....	22
Pascal's Law .....	25
Volume/Velocity.....	27
<b>Chapter 3 - Backflow</b> .....	<b>31</b>
Types of Backflow Preventers.....	39
Backflow Responsibilities.....	45
<b>Chapter 4 - Pathogens</b> .....	<b>57</b>
Hippocrates.....	59
Black Plague .....	65
Viral Diseases.....	73
Waterborne Diseases.....	75
<b>Chapter 5 - Plumbing Fittings</b> .....	<b>79</b>
Plastic Pipe.....	81
Solvent Cemeting.....	83
<b>Chapter 6 - Plumbing Repairs</b> .....	<b>89</b>
Toilets.....	101
Showers.....	111
Noises.....	115
<b>Chapter 7 - Drain &amp; Vents</b> .....	<b>121</b>
Sewer Gases.....	124
<b>Chapter 8 - Water Distribution</b> .....	<b>127</b>
Valve Glossary.....	133
Rotary Valves.....	143
Types of Pipes.....	179
Distribution Fittings.....	185
Water Main Installation.....	187
Glossary.....	191
Math conversions.....	201
References.....	205





## July 26, 2000 News Release

BEIJING (Reuters) - China has flushed Britain's claims to have invented the water closet down the pan with the discovery of a 2,000-year-old toilet complete with running water, a stone seat and a comfortable armrest.

Archaeologists found the antique latrine in the tomb of a king of the Western Han Dynasty (206 BC to 24 AD), who believed his soul would need to enjoy human life after death, the official Xinhua news agency said on Wednesday.

"This top-grade stool is the earliest of its kind ever discovered in the world, meaning that the Chinese used the world's earliest water closet which is quite like what we are using today," Xinhua quoted the archaeologists' report as saying.

***"It was a great invention and a symbol of social civilization of that time,"*** Xinhua said.

The invention of the flush toilet is widely attributed to London plumber Thomas Crapper, who patented a U-bend siphoning system for flushing the pan in the late 19th century, and who also installed toilets for Queen Victoria.

Among other inventions claimed by China are toilet paper, fireworks, gunpowder, the compass, paper money, kites, printing and the clock.

The toilet tomb was discovered in Shangqiu County in the central province of Henan, Xinhua said.

Archaeologists also found a queen consort's stone tomb, more than 690 feet long and consisting of more than 30 rooms including a bathroom, toilet, kitchen and an ice-store.



Water Closet or Urinal? Crappers have been here much longer than we may think. Much longer and that is a good thing.



Top, new and incredible, low VOC Volatile Organic Chemical is used in the production of this ball valve for water quality and Laboratory applications.

Below, Trap primer to maintain the seal inside a floor drain so that sewer odors do not come inside the building, Trap Primers are usually inside access panels in walls.



# Basic Plumbing - Chapter 1

## The Plumbing Code

The Code outlines the best and most modern methods to be used in plumbing installations. Since the plumbing in any private or public building is a part of the community water and sewage disposal system, it is vital that such installations should not be left to the discretion of irresponsible individuals. The protection of the public health and safety must be maintained by the establishment of sound code provisions. A plumbing or sanitation code is not a plumber's code. It is rather a set of Rules and Regulations imposed by cities, counties and states on anyone who undertakes any work involving the installation of drinking water, sewer or toilet facilities in homes, offices, factories, schools and hospitals. Regardless of who might do the work, plumbing and sanitation codes require that it be done in a specific, safe manner because it was found that failure to do so caused widespread disease, which can be crippling and deadly-to the community.



## Licensing

Plumbers must demonstrate their competence as installers of plumbing systems to an official executing board prior to being issued a license. A plumbing code which is technically perfect is valueless if its provisions are not observed and enforced. The issuance of a license by a community specifies that the license holder is qualified both theoretically and practically and that their technical knowledge is sufficient to maintain the standards of the code.

Is licensing intended to prevent anyone but a plumber from doing sanitation work?

Licensing prohibits the irresponsible, incapable person from endangering the health of your family, neighbors and community. Any person may do the work that has sufficient knowledge to do it in a safe manner, so long as the Rules and Regulations of the plumbing and sanitation code are observed.



However, those wishing to do such work must demonstrate their ability by taking out a license and passing an examination. Most States require that, like a doctor, nurse, dentist or pharmacist, anyone whose work affects the public health and safety shall have adequate knowledge and training.

No one wants a "quack doctor" to treat his family or a "soda clerk" to fill his prescriptions. For precisely the same reasons, one does not want a "handyman" to do work in his home, office or factory which can adversely affect the health of his family, his employees or his neighbors.

Done improperly, this work would probably need to be rectified at the time the property changed hands, which means paying twice for the same work.



Building Permit Counter

### **Inspection and Permits**

Through the issuance of permits and the requirements of public inspection, a community can assure itself of proper plumbing code enforcement. The permit allows the plumbing inspector to protect the consumer by assuring plumbing installations are done properly. The inspection of such plumbing work insures that the installation is being completed in accordance with code provisions.

### **It Pays to Take Care of Our Plumbing**

The average household plumbing system represents an investment of about fifteen percent of the value of the house. No part of the house is more important. Nothing in the house is used more often. A smoothly functioning plumbing system is a pin to health and adds to the convenience of modern living.

There are many things that an owner or renter can do; there are many things that should be left to an expert-the plumbing contractor and his staff of journeymen plumbers.

Minor repairs should be made promptly. Annoyances such as a clogged drain, dripping faucet or a leaking flush valve in the toilet, are more than a mere bother - they usually waste money. This booklet suggests remedies for these and many other household plumbing problems.

Major repairs, replacements, and new plumbing installations should be left to the supervision of a plumbing contractor. His working methods are based on years of experience - and his guarantee is assurance that all materials and methods are of the highest quality.

## Where and How to Shut-Off Water

Knowing where and how to shut off water for the entire house or any part of it can be mighty important in an emergency. That's why it is extremely important for all members of the family to know where the valves are and in which direction they should be turned to shut off the water.

One way to identify the valves is to have a tag on each valve indicating its function, that is, which fixtures or group of fixtures it controls. Valve identifying tags may be obtained from plumbing dealers. Many plumbers are glad to offer a valve tagging service to their customers or prospective customers.

Another method of identification is by means of a valve chart. Because this is somewhat more elaborate, it is usually employed only for houses with several bathrooms. A drawing is made of the basement piping with all the valves indicated. The valves are numbered on the chart and tags with corresponding numbers are placed on the valves. Still another idea which aids in identification is to paint pipes a distinctive color.

Obviously, the most important valve in the house is the main shut-off valve for the entire plumbing system. This valve, generally located on the house side or service of the water meter, usually has a handle like a wheel. If it has not been used in many years, it may require a wrench to turn it. Because the easy operation of this valve in case of emergency is so important, it is advisable to place a few drops of oil around the valve handle once or twice a year. This will prevent the sticking action of corrosion.

The shut-off valve may be the ground-key type with a small hole bored in its side for draining the pipes after the water is shut off, or it may be a drain and stop with a cap nut covering the drain opening. In either case, close the opening before turning the water off. Unless this is done, water will spurt with force.

Where no means has been provided for shutting off a drain opening, drive a small wooden peg into it until the pressure is relieved by draining the piping that is exposed.

In addition to the main shut-off valve at the meter, the well plumbed house has individual shut-off valves on the branch lines leading to individual fixtures, groups of fixtures or equipment such as water heaters, water softeners, automatic washers, etc.

Many contractors, when installing plumbing fixtures, provide separate shut-off valves or stops for each individual fixture. These will be found on the supply lines below the fixture. These individual stops are a great convenience to regulate water flow in case of repairs as well as emergencies.



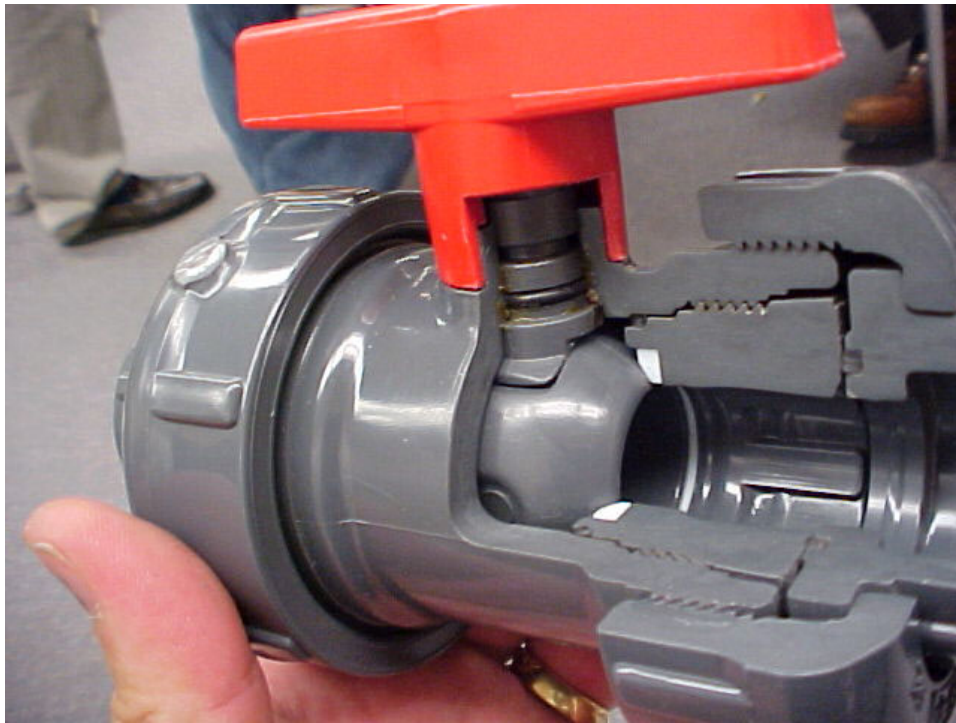

Upper, cut away of a Ball Valve.  
Below, cut away of a Gate Valve.

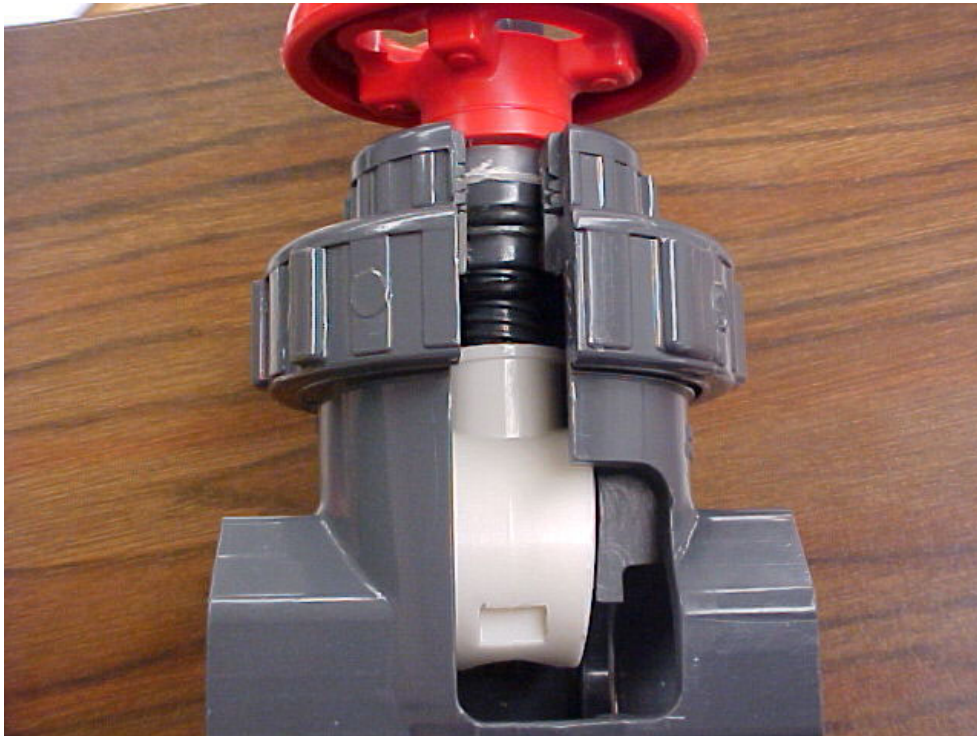

# Hydraulic Principles - Chapter 2

## Hydrostatics

Hydrostatics is about the pressures exerted by a fluid at rest. Any fluid is meant, not just water. Research and careful study on water yields many useful results of its own, however, such as forces on dams, buoyancy and hydraulic actuation, and is well worth studying for such practical reasons.

Hydrostatics is an excellent example of deductive mathematical physics, one that can be understood easily and completely from a very few fundamentals, and in which the predictions agree closely with experiment.

There are few better illustrations of the use of the integral calculus, as well as the principles of ordinary statics, available to the student. A great deal can be done with only elementary mathematics. Properly adapted, the material can be used from the earliest introduction of school science, giving an excellent example of a quantitative science with many possibilities for hands-on experiences.

The definition of a fluid deserves careful consideration. Although time is not a factor in hydrostatics, it enters in the approach to hydrostatic equilibrium. It is usually stated that a fluid is a substance that cannot resist a shearing stress, so that pressures are normal to confining surfaces. Geology has now shown us clearly that there are substances which can resist shearing forces over short time intervals, and appear to be typical solids, but which flow like liquids over long time intervals. Such materials include wax and pitch, ice, and even rock.

A ball of pitch, which can be shattered by a hammer, will spread out and flow in months. Ice, a typical solid, will flow in a period of years, as shown in glaciers, and rock will flow over hundreds of years, as in convection in the mantle of the earth.

Shear earthquake waves, with periods of seconds, propagate deep in the earth, though the rock there can flow like a liquid when considered over centuries. The rate of shearing may not be strictly proportional to the stress, but exists even with low stress.

Viscosity may be the physical property that varies over the largest numerical range, competing with electrical resistivity. There are several familiar topics in hydrostatics which often appears in expositions of introductory science, and which are also of historical interest and can enliven their presentation. Let's start our study with the principles of our atmosphere.

## Atmospheric Pressure

The atmosphere is the entire mass of air that surrounds the earth. While it extends upward for about 500 miles, the section of primary interest is the portion that rests on the earth's surface and extends upward for about 7 1/2 miles. This layer is called the troposphere. If a column of air 1-inch square extending all the way to the "top" of the atmosphere could be weighed, this column of air would weigh approximately 14.7 pounds at sea level. Thus, atmospheric pressure at sea level is approximately 14.7 psi.

As one ascends, the atmospheric pressure decreases by approximately 1.0 psi for every 2,343 feet. However, below sea level, in excavations and depressions, atmospheric pressure increases.

Pressures under water differ from those under air only because the weight of the water must be added to the pressure of the air.

Atmospheric pressure can be measured by any of several methods. The common laboratory method uses the mercury column barometer. The height of the mercury column serves as an indicator of atmospheric pressure. At sea level and at a temperature of 0° Celsius (C), the height of the mercury column is approximately 30 inches, or 76 centimeters. This represents a pressure of approximately 14.7 psi. The 30-inch column is used as a reference standard.

Another device used to measure atmospheric pressure is the aneroid barometer. The aneroid barometer uses the change in shape of an evacuated metal cell to measure variations in atmospheric pressure. The thin metal of the aneroid cell moves in or out with the variation of pressure on its external surface. This movement is transmitted through a system of levers to a pointer, which indicates the pressure.

The atmospheric pressure does not vary uniformly with altitude. It changes more rapidly. Atmospheric pressure is defined as the force per unit area exerted against a surface by the weight of the air above that surface.

In the diagram below, the pressure at point "X" increases as the weight of the air above it increases. The same can be said about decreasing pressure, where the pressure at point "X" decreases if the weight of the air above it also decreases.

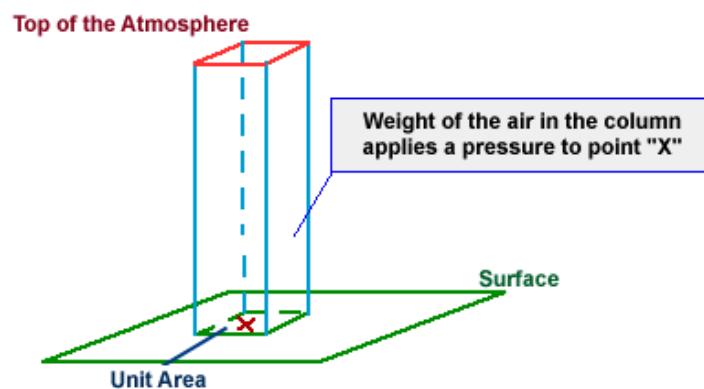

Pressure may be referred to using an absolute scale, pounds per square inch absolute (psia), or gauge scale, (psiag). Absolute pressure and gauge pressure are related. Absolute pressure is equal to gauge pressure plus the atmospheric pressure. At sea level, the atmospheric pressure is 14.7 psai.

Absolute pressure is the total pressure. Gauge pressure is simply the pressure read on the gauge. If there is no pressure on the gauge other than atmospheric, the gauge will read zero. Then the absolute pressure would be equal to 14.7 psi, which is the atmospheric pressure.



## Barometric Loop

The barometric loop consists of a continuous section of supply piping that abruptly rises to a height of approximately 35 feet and then returns back down to the originating level. It is a loop in the piping system that effectively protects against backsiphonage. It may not be used to protect against back-pressure.

Its operation, in the protection against backsiphonage, is based upon the principle that a water column, at sea level pressure, will not rise above 33.9 feet. In general, barometric loops are locally fabricated, and are 35 feet high.

Pressure may be referred to using an absolute scale, pounds per square inch absolute (**psia**), or gauge scale, (**psig**). Absolute pressure and gauge pressure are related.

Absolute pressure is equal to gauge pressure plus the atmospheric pressure. At sea level, the atmospheric pressure is 14.7 psia.

Absolute pressure is the total pressure.

Gauge pressure is simply the pressure read on the gauge.

If there is no pressure on the gauge other than atmospheric, the gauge will read zero. Then the absolute pressure would be equal to 14.7 psi, which is the atmospheric pressure.

### Vacuum

The term *vacuum* indicates that the absolute pressure is less than the atmospheric pressure and that the gauge pressure is negative. A complete or total vacuum would mean a pressure of 0 psia or -14.7 psig.

Since it is impossible to produce a total vacuum, the term vacuum, as used in this document, will mean all degrees of partial vacuum.

In a partial vacuum, the pressure would range from slightly less than 14.7 psia (0 psig) to slightly greater than 0 psia (-14.7 psig).

Backsiphonage results from atmospheric pressure exerted on a liquid, forcing it toward a supply system that is under a vacuum.

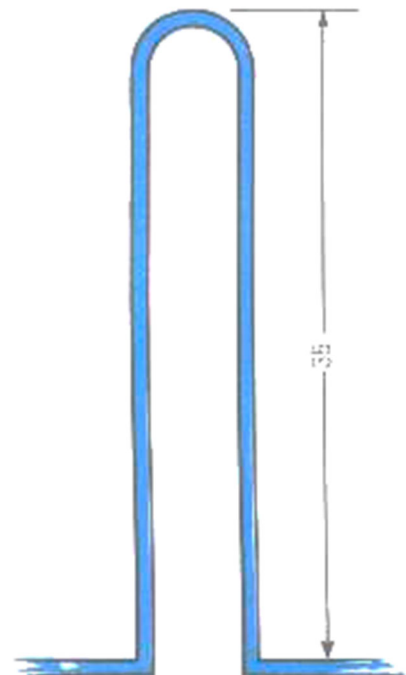

## **Water Pressure**

The weight of a cubic foot of water is 62.4 pounds per square foot. The base can be subdivided into 144-square inches with each subdivision being subjected to a pressure of 0.433 psig.

Suppose you placed another cubic foot of water on top of the first cubic foot. The pressure on the top surface of the first cube which was originally atmospheric, or 0 psig, would now be 0.4333 psig as a result of the additional cubic foot of water. The pressure of the base of the first cubic foot would be increased by the same amount of 0.866 psig or two times the original pressure.

## **Hydraulics**

The word *hydraulics* is based on the Greek word for water, and originally covered the study of the physical behavior of water at rest and in motion.

Use has broadened its meaning to include the behavior of all liquids, although it is primarily concerned with the motion of liquids. Hydraulics include the manner in which liquids act in tanks and pipes, deals with their properties, and explores ways to take advantage of these properties.

Hydraulics is a branch of engineering concerned mainly with moving liquids. The term is applied commonly to the study of the mechanical properties of water, other liquids, and even gases when the effects of compressibility are small.

Hydraulics can be divided into two areas, hydrostatics and hydrokinetics. Hydrostatics, the consideration of liquids at rest, involves problems of buoyancy and flotation, pressure on dams and submerged devices, and hydraulic presses.

## **Hydrodynamics**

The relative incompressibility of liquids is one of its basic principles. Hydrodynamics, the study of liquids in motion, is concerned with such matters as friction and turbulence generated in pipes by flowing liquids, the flow of water over weirs and through nozzles, and the use of hydraulic pressure in machinery.

## **Development of Hydraulics**

Although the modern development of hydraulics is comparatively recent, the ancients were familiar with many hydraulic principles and their applications. The Egyptians and the ancient people of Persia, India, and China conveyed water along channels for irrigation and domestic purposes, using dams and sluice gates to control the flow. The ancient Cretans had an elaborate plumbing system. Archimedes studied the laws of floating and submerged bodies. The Romans constructed aqueducts to carry water to their cities.

After the breakup of the ancient world, there were few new developments for many centuries. Then, over a comparatively short period, beginning near the end of the seventeenth century, Italian physicist Evangelista Torricelle, French physicist Edme Mariotte and, later, Daniel Bernoulli conducted experiments to study the elements of force in the discharge of water through small openings in the sides of tanks and through short pipes.

During the same period, Blaise Pascal, a French scientist, discovered the fundamental law for the science of hydraulics. Pascal's law states that increase in pressure on the surface of a confined fluid is transmitted undiminished throughout the confining vessel or system. For Pascal's law to be made effective for practical applications, it was necessary to have a piston that "fit exactly."

It was not until the latter part of the eighteenth century that methods were found to make these snugly fitted parts required in hydraulic systems.

This was accomplished by the invention of machines that were used to cut and shape the necessary closely fitted parts and, particularly, by the development of gaskets and packings. Since that time, components such as valves, pumps, actuating cylinders, and motors have been developed and refined to make hydraulics one of the leading methods of transmitting power.

Liquids are almost incompressible. For example, if a pressure of 100 pounds per square inch (psi) is applied to a given volume of water that is at atmospheric pressure, the volume will decrease by only 0.03 percent.

It would take a force of approximately 32 tons to reduce its volume by 10 percent; however, when this force is removed, the water immediately returns to its original volume. Other liquids behave in about the same manner as water.

Another characteristic of a liquid is the tendency to keep its free surface level.

If the surface is not level, liquids will flow in the direction which will tend to *make* the surface level.

### **Liquids at Rest**

In studying fluids at rest, we are concerned with the transmission of force and the factors which affect the forces in liquids. Additionally, pressure in and on liquids and factors affecting pressure are of great importance.

### **Pressure and Force**

Pressure is the force that pushes water through pipes. Water pressure determines the flow of water from the tap. If pressure is not sufficient then the flow can reduce to a trickle and it will take a long time to fill a kettle or a cistern.

The terms *force* and *pressure* are used extensively in the study of fluid power. It is essential that we distinguish between the terms.

Force means a total push or pull. It is the push or pull exerted against the total area of a particular surface and is expressed in pounds or grams.

Pressure means the amount of push or pull (force) applied to each unit area of the surface and is expressed in pounds per square inch (lb/in<sup>2</sup>) or grams per square centimeter (gm/cm<sup>2</sup>). Pressure may be exerted in one direction, in several directions, or in all directions.

### Computing Force, Pressure, and Area

A formula is used in computing force, pressure, and area in fluid power systems. In this formula, P refers to pressure, F indicates force, and A represents area. Force equals pressure times area. Thus, the formula is written:



UNIT	ABBREVIATION	EQUIVALENT NUMBER OF PASCALS
ATMOSPHERE	atm	1 atm = 101,325 Pa
BAR	bar	1 bar = 100,025 Pa
MILLIMETER OF MERCURY	mmHg	1 mmHg = 133.322 Pa
INCHES OF MERCURY	inHg	1 inHg = 3386 Pa
PASCAL	Pa	1
KILOPASCAL	kPa	1 kPa = 1000 Pa
POUNDS PER SQUARE INCH	psi	1 psi = 6,893 Pa
TORR	torr	1 torr = 133.322 Pa



### DIFFERENT UNITS OF PRESSURE

## Pascal's Law

The foundation of modern hydraulics was established when Pascal discovered that pressure in a fluid acts equally in all directions. This pressure acts at right angles to the containing surfaces. If some type of pressure gauge, with an exposed face, is placed beneath the surface of a liquid at a specific depth and pointed in different directions, the pressure will read the same. Thus, we can say that pressure in a liquid is independent of direction.

Pressure due to the weight of a liquid, at any level, depends on the depth of the fluid from the surface. If the exposed face of the pressure gauges are moved closer to the surface of the liquid, the indicated pressure will be less. When the depth is doubled, the indicated pressure is doubled. Thus the pressure in a liquid is directly proportional to the depth.

Consider a container with vertical sides that is 1 foot long and 1 foot wide. Let it be filled with water 1 foot deep, providing 1 cubic foot of water. 1 cubic foot of water weighs 62.4 pounds. Using this information and equation,  $P = F/A$ , we can calculate the pressure on the bottom of the container.

Since there are 144 square inches in 1 square foot, this can be stated as follows: the weight of a column of water 1 foot high, having a cross-sectional area of 1 square inch, is 0.433 pound. If the depth of the column is tripled, the weight of the column will be  $3 \times 0.433$ , or 1.299 pounds, and the pressure at the bottom will be 1.299 lb/in<sup>2</sup> (psi), since pressure equals the force divided by the area.

Thus, the pressure at any depth in a liquid is equal to the weight of the column of liquid at that depth divided by the cross-sectional area of the column at that depth.

The volume of a liquid that produces the pressure is referred to as the fluid head of the liquid. The pressure of a liquid due to its fluid head is also dependent on the density of the liquid.

### Gravity

Gravity is one of the four forces of nature. The strength of the gravitational force between two objects depends on their masses. The more massive the objects are, the stronger the gravitational attraction.

When you pour water out of a container, the earth's gravity pulls the water towards the ground. The same thing happens when you put two buckets of water, with a tube between them, at two different heights. You must do work to start the flow of water from one bucket to the other, but then gravity takes over and the process will continue on its own.

Gravity, applied forces, and atmospheric pressure are static factors that apply equally to fluids at rest or in motion, while inertia and friction are dynamic factors that apply only to fluids in motion.

The mathematical sum of gravity, applied force, and atmospheric pressure is the static pressure obtained at any one point in a fluid at any given time.

## Static Pressure

Static pressure exists in addition to any dynamic factors that may also be present at the same time.

Pascal's law states that a pressure set up in a fluid acts equally in all directions and at right angles to the containing surfaces.

This covers the situation only for fluids at rest or practically at rest. It is true only for the factors making up static head. Obviously, when velocity becomes a factor it must have a direction, and as previously explained, the force related to the velocity must also have a direction, so that Pascal's law alone does not apply to the dynamic factors of fluid power.

The dynamic factors of inertia and friction are related to the static factors. Velocity head and friction head are obtained at the expense of static head. However, a portion of the velocity head can always be reconverted to static head.

Force, which can be produced by pressure or head when dealing with fluids, is necessary to start a body moving if it is at rest, and is present in some form when the motion of the body is arrested; therefore, whenever a fluid is given velocity, some part of its original static head is used to impart this velocity, which then exists as velocity head.

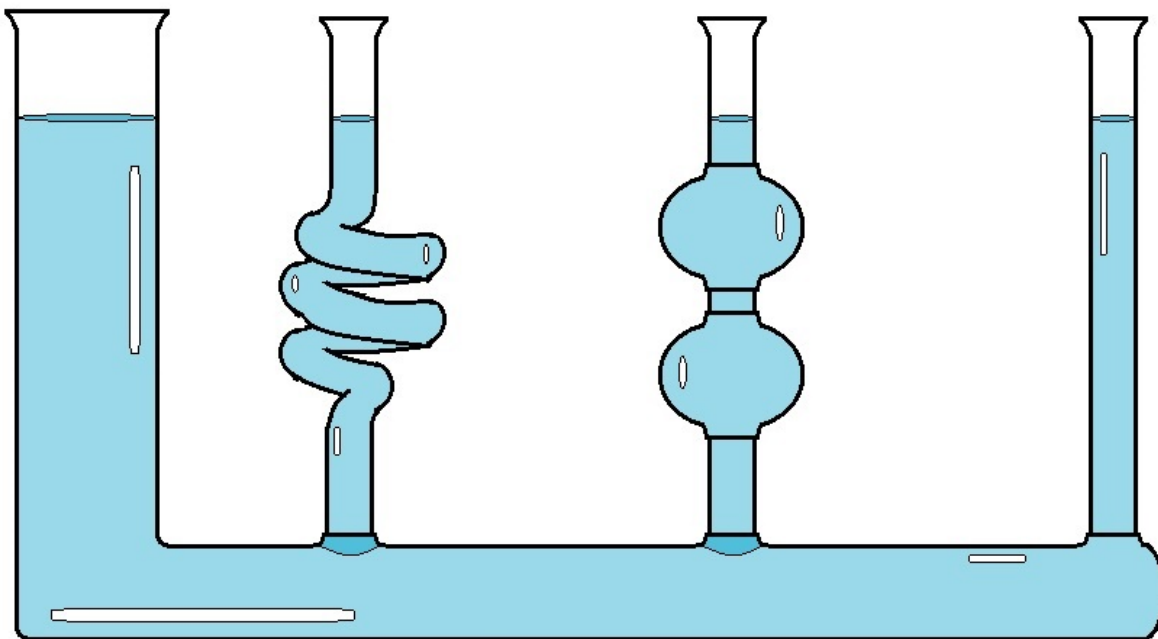

## PRESSURE IN LIQUIDS

**PASCAL'S VASES DEMONSTRATE THE FACT THAT THE PRESSURE OF THE LIQUID DEPENDS SOLELY ON THE DEPTH ALONE, AND NOT THE VOLUME OR THE SHAPE OF THE FLUID**



## Volume and Velocity of Flow

The volume of a liquid passing a point in a given time is known as its *volume of flow* or flow rate. The volume of flow is usually expressed in gallons per minute (gpm) and is associated with relative pressures of the liquid, such as 5 gpm at 40 psi.

The *velocity of flow* or velocity of the fluid is defined as the average speed at which the fluid moves past a given point. It is usually expressed in feet per second (fps) or feet per minute (fpm). Velocity of flow is an important consideration in sizing the hydraulic lines.

Volume and velocity of flow are often considered together. With other conditions unaltered—that is, with volume of input unchanged—the velocity of flow increases as the cross section or size of the pipe decreases, and the velocity of flow decreases as the cross section increases. For example, the velocity of flow is slow at wide parts of a stream and rapid at narrow parts, yet the volume of water passing each part of the stream is the same.

### Bernoulli's Principle

Bernoulli's principle thus says that a rise (fall) in pressure in a flowing fluid must always be accompanied by a decrease (increase) in the speed; and conversely, an increase (decrease) in the speed of the fluid results in a decrease (increase) in the pressure.

This is at the heart of a number of everyday phenomena. As a very trivial example, Bernoulli's principle is responsible for the fact that a shower curtain gets "*sucked inwards*" when the water is first turned on. What happens is that the increased water/air velocity inside the curtain (relative to the still air on the other side) causes a pressure drop.

The pressure difference between the outside and inside causes a net force on the shower curtain which sucks it inward. A more useful example is provided by the functioning of a perfume bottle: squeezing the bulb over the fluid creates a low-pressure area due to the higher speed of the air, which subsequently draws the fluid up.

This is illustrated in the following figure.

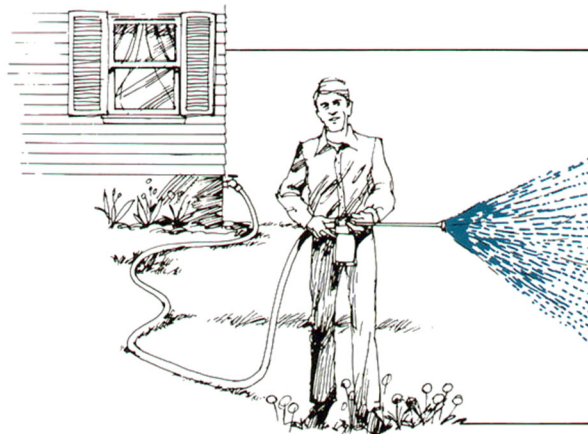

Action of a spray atomizer

## Bernoulli's Principle

Bernoulli's principle also tells us why windows tend to explode, rather than implode in hurricanes: the very high speed of the air just outside the window causes the pressure just outside to be much less than the pressure inside, where the air is still. The difference in force pushes the windows outward, and hence they explode. If you know that a hurricane is coming it is therefore better to open as many windows as possible, to equalize the pressure inside and out.

Another example of Bernoulli's principle at work is in the lift of aircraft wings and the motion of "curve balls" in baseball. In both cases, the design is such as to create a speed differential of the flowing air past the object on the top and the bottom - for aircraft wings this comes from the movement of the flaps, and for the baseball it is the presence of ridges. Such a speed differential leads to a pressure difference between the top and bottom of the object, resulting in a net force being exerted, either upwards or downwards.

## Properties of Water

Specific gravity of water at 60°F = 1.00

Weight per gallon is based on 7.48052 gallons per cubic foot.

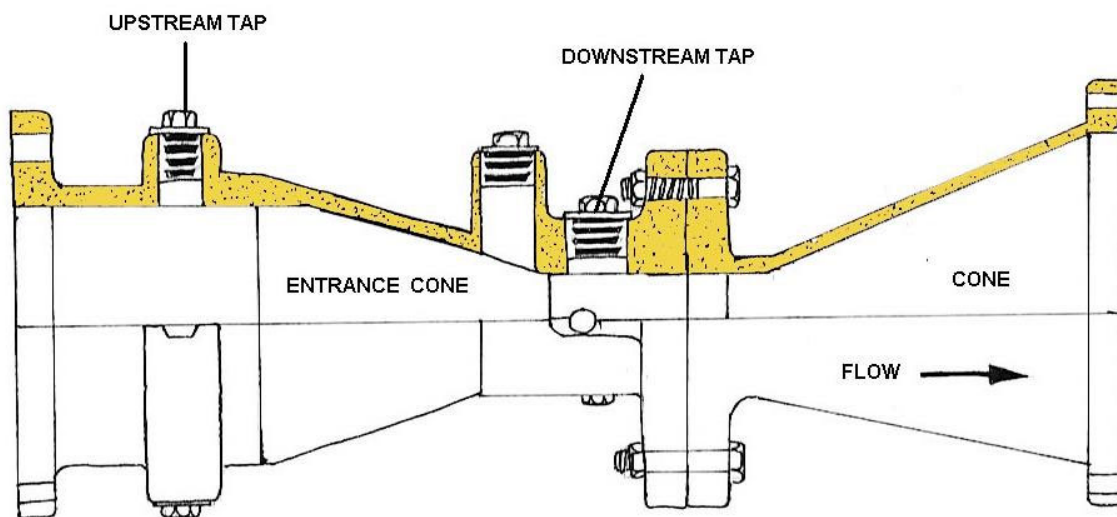

**VENTURI TUBE DIAGRAM**



## **Review Statements**

Hydrostatics is an excellent example of deductive mathematical physics, and in which the predictions agree closely with experiment and is usually stated that a fluid is a substance that cannot resist a shearing stress, so that pressures are normal to confining surfaces.

Hydrostatics may be the physical property that varies over the largest numerical range, competing with electrical resistivity.

## **Pressure**

Water is incompressible, while air is very compressible. A fluid is a substance that cannot exert any permanent forces tangential to a boundary and any force that it exerts on a boundary must be normal to the boundary. Both air and water are considered to be fluids.

Water possess volume while air does not.

A force is proportional to the area on which it is exerted, and is called a pressure.

## **Water Pressure**

Pressure are very frequently stated in terms of the height of a fluid.

Water with a pressure head of 20 ft can provide the same energy as an equal amount of water raised by 20 ft.

The weight of a cubic foot of water is 62.4 pounds per square foot. The base can be subdivided into 144-square inches with each subdivision being subjected to a pressure of 0.433 psig. This is one of our key foundation for backflow prevention.



## Backflow Prevention - Chapter 3

Backflow Prevention, also referred to as Cross-Connection Control, addresses a serious health issue. This issue was addressed on the federal level by passage of the "*Federal Safe Drinking Water Act*" as developed by the Environmental Protection Agency (E.P.A.) and passed into law on December 16, 1974. This Act tasked each state with primary enforcement responsibility for a program to assure access to safe drinking water by all citizens. Such state program regulations as adopted are required to be at least as stringent as the federal regulations as developed and enforced by the E.P.A.

The official definition of a cross-connection is "*the link or channel connecting a source of pollution with a potable water supply.*" There are two distinct levels of concern with this issue. The first is protection of the general public and the second is protection of persons' subject to such risks involving service to a single customer, be that customer an individual residence or business.

Sources of pollution which may result in a danger to health are not always obvious and such cross-connections are certainly not usually intentional. They are usually the result of oversight or a non-professional installation. As source examples, within a business environment the pollutant source may involve the unintentional cross-connection of internal or external piping with chemical processes or a heating boiler. In a residential environment the pollutant source may be an improper cross-connection with a landscape sprinkler system or reserve tank fire protection system. Or, a situation as simple as leaving a garden hose nozzle submerged in a bucket of liquid or attached to a chemical sprayer.

Another potential hazard source within any environment may be a cross-connection of piping involving a water well located on the property. This is a special concern with older residences or businesses, which may have been served by well water prior to connection to the developed water system. There are many other potential sources of pollutant hazards. Control of cross-connections is possible but only through knowledge and vigilance. Public education is essential, for many that are educated in piping and plumbing installations fail to recognize cross-connection dangers.



Another buried RP assembly deep inside a vault, all we can see is a test cock. All RPs need to be installed 12 inches above the ground. This device was buried in ground and not tested for over 25 years. Owners are required to test their devices once a year at a minimum.



Top photo, a Hot Box, a good method of keeping the assembly from freezing during the winter. Bottom, electrical heat tape method for freeze protection.



## Cross-Connection Terms

### Cross-Connection

A cross-connection is any temporary or permanent connection between a public water system or consumer's potable (i.e., drinking) water system and any source or system containing nonpotable water or other substances.

An example is the piping between a public water system or consumer's potable water system and an auxiliary water system, cooling system, or irrigation system.

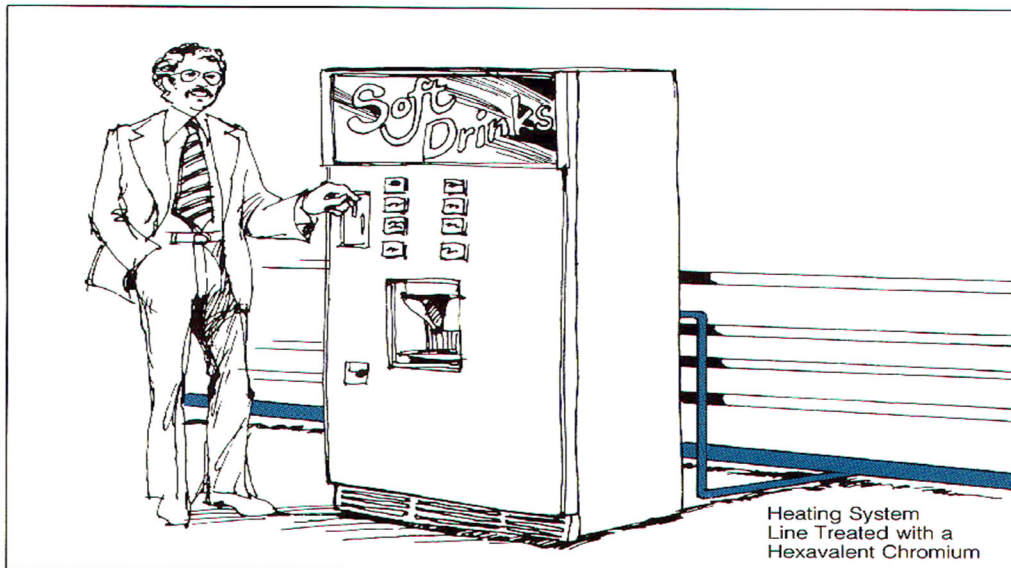
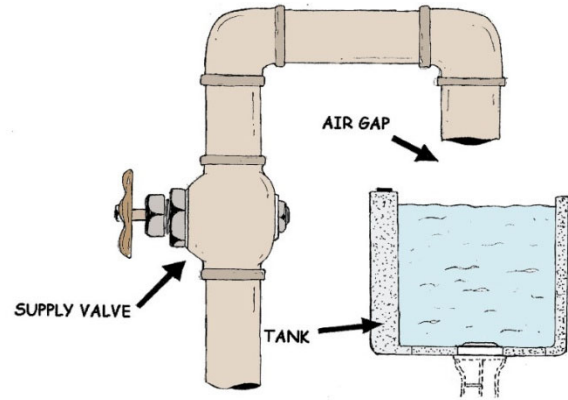

**Common Cross-Connections**

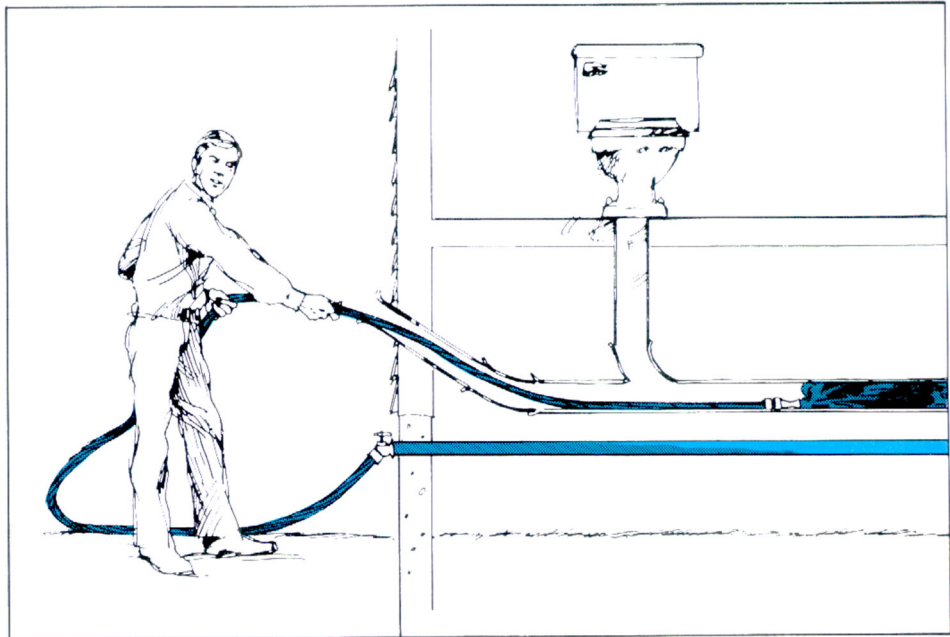
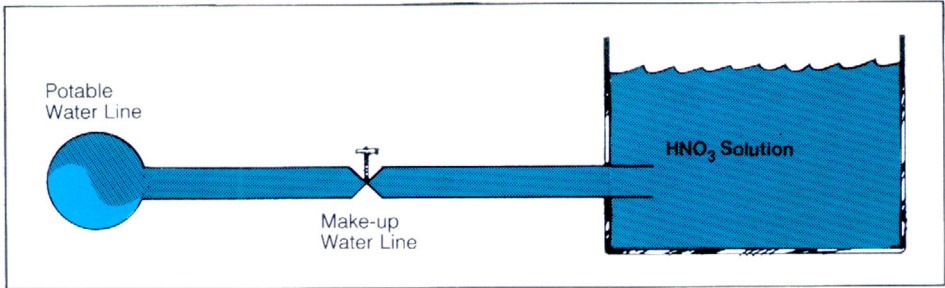
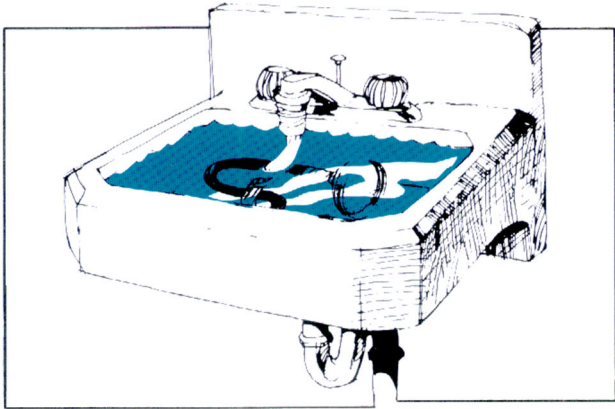

## Backflow

Backflow is the undesirable reversal of flow of nonpotable water or other substances through a cross-connection and into the piping of a public water system or consumer's potable water system. There are two types of backflow--**backpressure** and **backsiphonage**.

### Backsiphonage

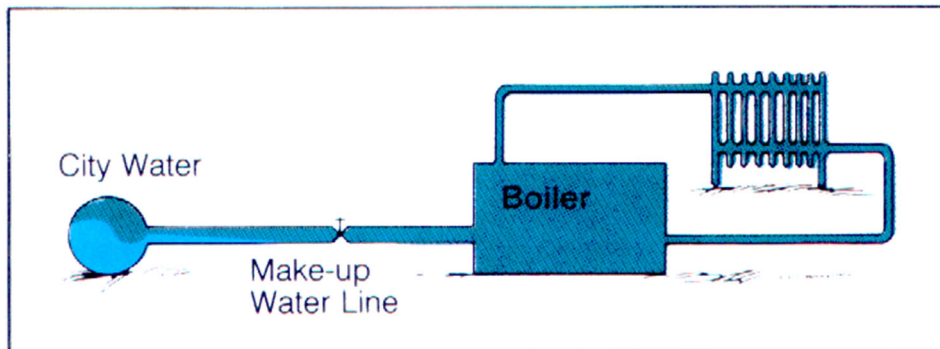

### Backpressure

## **Backsiphonage**

Backsiphonage is backflow caused by a negative pressure (i.e., a vacuum or partial vacuum) in a public water system or consumer's potable water system. The effect is similar to drinking water through a straw.

Backsiphonage can occur when there is a stoppage of water supply due to nearby firefighting, a break in a water main, etc.

*All backflow materials are used by permission from CMB Industries, Inc*

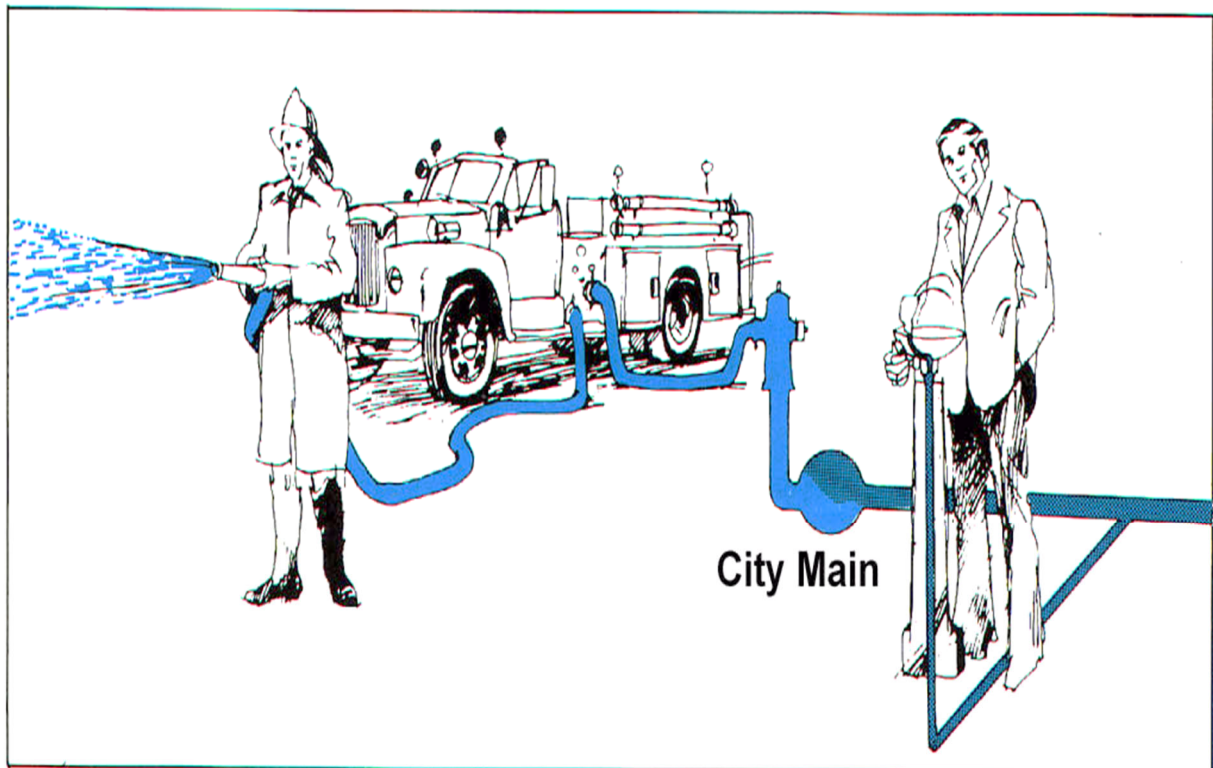



## Backpressure

Backpressure backflow is backflow caused by a downstream pressure that is greater than the upstream or supply pressure in a public water system or consumer's potable water system.

Backpressure (i.e., downstream pressure that is greater than the potable water supply pressure) can result from an increase in downstream pressure, a reduction in the potable water supply pressure, or a combination of both. Increases in downstream pressure can be created by pumps, temperature increases in boilers, etc.

Reductions in potable water supply pressure occur whenever the amount of water being used exceeds the amount of water being supplied, such as during water line flushing, firefighting, or breaks in water mains.

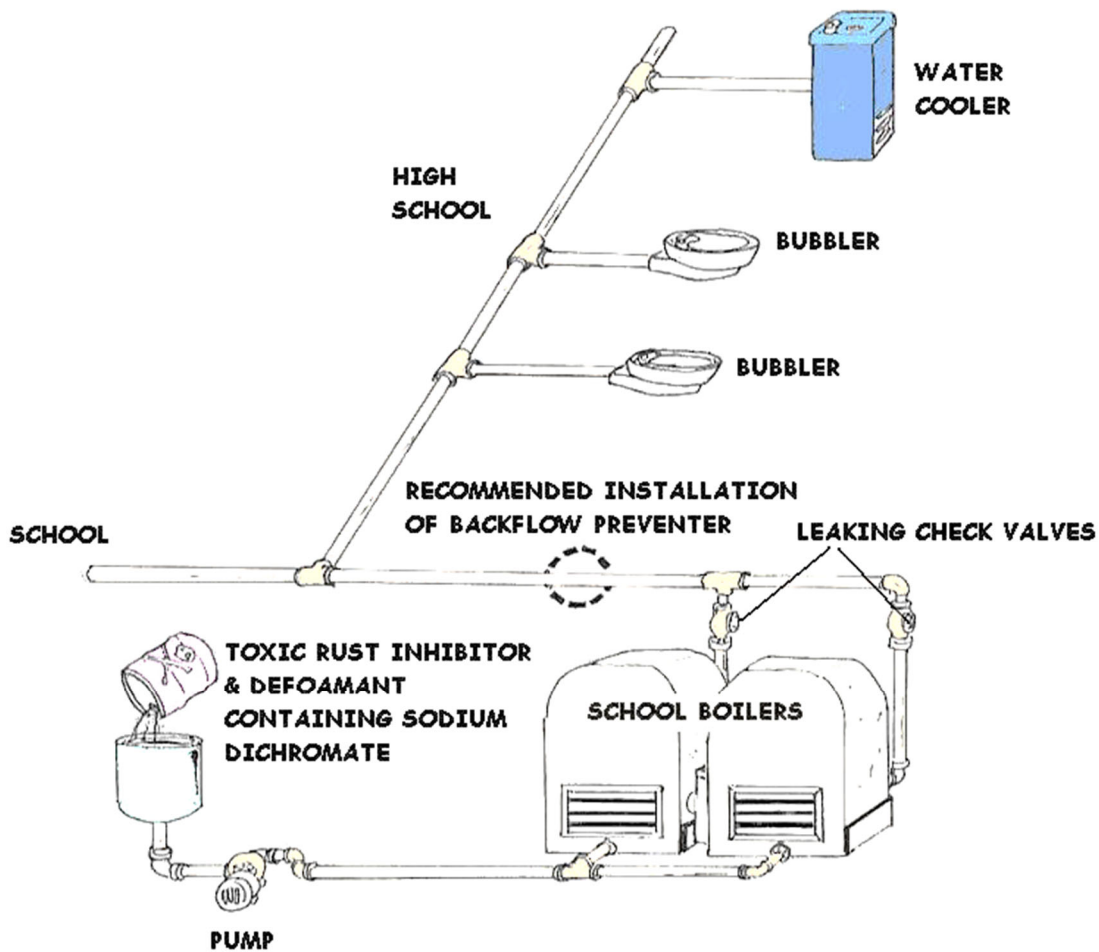

**Backpressure Example:**

***Booster pumps, pressure vessels***

*All backflow materials are used by permission from CMB Industries, Inc*

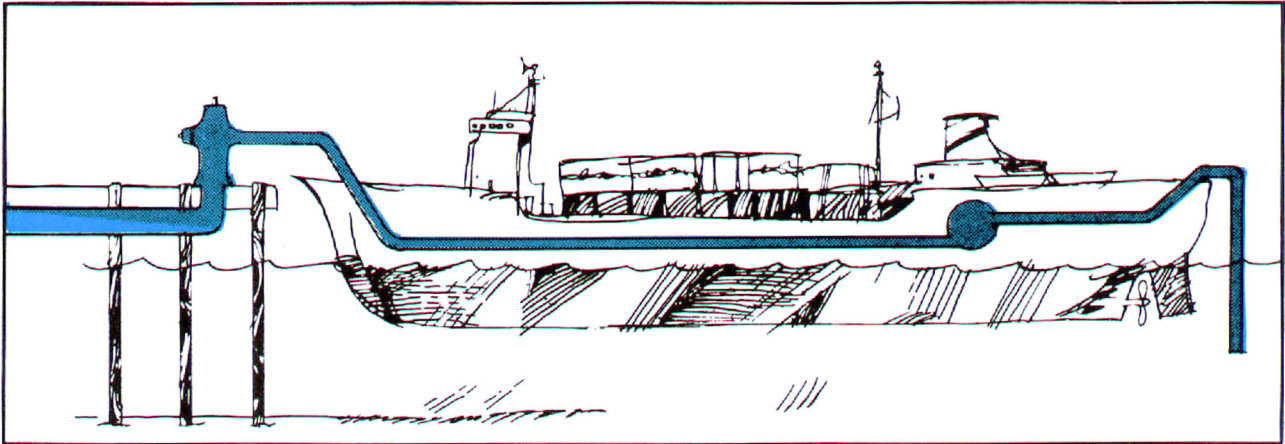

## Types of Backflow Prevention Methods and Assemblies

### Backflow Devices

Cross connections must either be physically disconnected or have an approved backflow prevention device installed to protect the public water system. There are five types of approved devices/methods:

1. **Air gap- *Is not really a device but is a method.***
2. **Atmospheric vacuum breaker**
3. **Pressure vacuum breaker**
4. **Double check valve**
5. **Reduced pressure principle backflow preventer (RP device)**

The type of device selected for a particular installation depends on several factors. First, the degree of hazard must be assessed. A high hazard facility is one in which a cross connection could be hazardous to health, such as a chrome plating shop or a sewage treatment plant. A low hazard situation is one in which a cross connection would cause only an aesthetic problem such as a foul taste or odor.

Second, the plumbing arrangement must be considered.

Third, it must be determined whether protection is needed at the water meter or at a location within the facility. A summary of these factors and the recommended device selection is given in Table 7-1.

### Approved Air Gap Separation (AG)

An approved air gap is a physical separation between the free flowing discharge end of a potable water supply pipeline, and the overflow rim of an open or non-pressure receiving vessel. These separations must be vertically orientated a distance of at least twice the inside diameter of the inlet pipe, but never less than one inch.

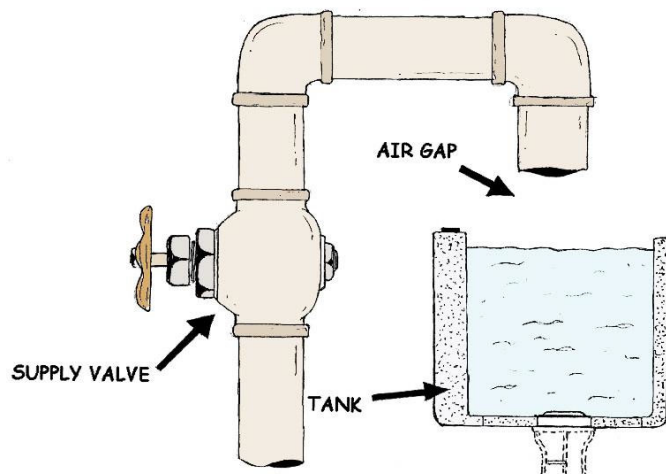

An obstruction around or near an air gap may restrict the flow of air into the outlet pipe and nullify the effectiveness of the air gap to prevent backsiphonage. When the air flow is restricted, such as the case of an air gap located near a wall, the air gap separation must be increased. Also, within a building where the air pressure is artificially increased above atmospheric, such as a sports stadium with a flexible roof kept in place by air blowers, the air gap separation must be increased.



Which of these ice machine drains has an approved air gap? Here is a better question; would you use the ice from this ice machine? Here is where all those stories about cockroaches and stomach flu originate. The stories are true.

## Air Gap

An air gap is a physical disconnection between the free flowing discharge end of a potable water pipeline and the top of an open receiving vessel. The air gap must be at least two times the diameter of the supply pipe and not less than one inch. This type of protection is acceptable for high hazard installations and is theoretically the most effective protection.

However, this method of prevention can be circumvented if the supply pipe is extended.



## Vacuum Breakers

There are two types of vacuum breakers, atmospheric and pressure. The difference between them is that the pressure vacuum breaker is spring loaded to assist the device's opening. Both devices open the pipeline to atmosphere in the event of backsiphonage only. Neither device is approved for backpressure conditions. Both devices are only suitable for low hazard applications. Their primary purpose is to protect the water system from cross connections due to submerged inlets, such as irrigation systems and tank applications. Shutoff valves may not be installed downstream of atmospheric vacuum breakers but are allowed on pressure vacuum breakers. The devices must be installed above the highest downstream piping.

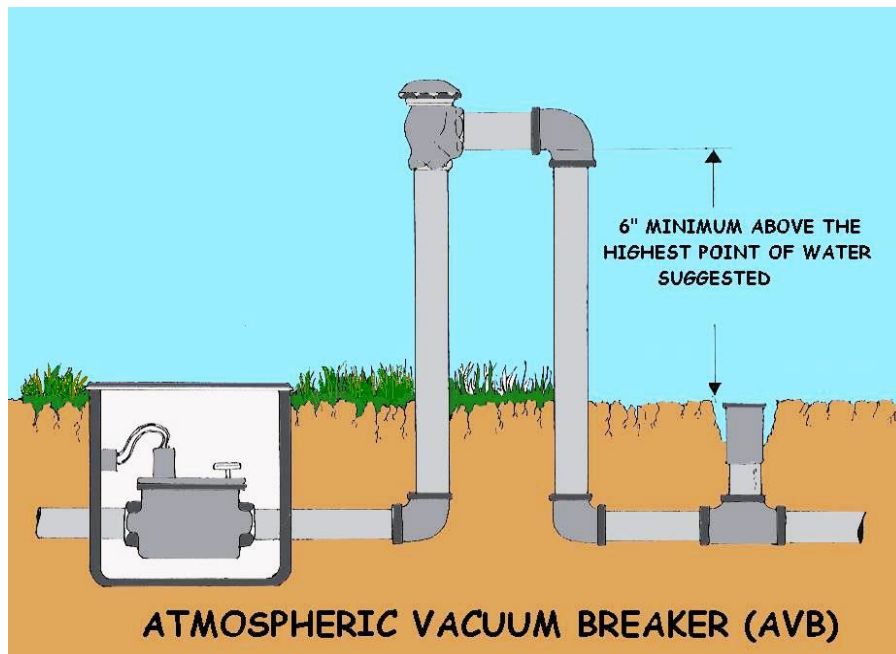

**Atmospheric Vacuum Breaker (AVB)** The Atmospheric Vacuum Breaker contains a float check (poppet), a check seat, and an air inlet port. The device allows air to enter the water line when the line pressure is reduced to a gauge pressure of zero or below. The air inlet valve is not internally loaded. To prevent the air inlet from sticking closed, the device must not be installed on the pressure side of a shutoff valve, or wherever it may be under constant pressure more than 12 hours during a 24 hour period.

Atmospheric vacuum breakers are designed to prevent backflow caused by backsiphonage only from low health hazards. Atmospheric Vacuum Breaker Uses: Irrigation systems, commercial dishwasher and laundry equipment, chemical tanks and laboratory sinks (backsiphonage only, non-pressurized connections.) (Note: hazard relates to the water purveyor's risk assessment; plumbing codes may allow AVB for high hazard fixture isolation).

## Pressure Vacuum Breaker Assembly (PVB)

The Pressure Vacuum Breaker Assembly consists of a spring loaded check valve, an independently operating air inlet valve, two resilient seated shutoff valves, and two properly located resilient seated test cocks. It shall be installed as a unit as shipped by the manufacturer. The air inlet valve is internally loaded to the open position, normally by means of a spring, allowing installation of the assembly on the pressure side of a shutoff valve. The PVB needs to be installed 12 inches above the highest downstream outlet to work correctly.

PRESSURE VACUUM BREAKER ASSEMBLY

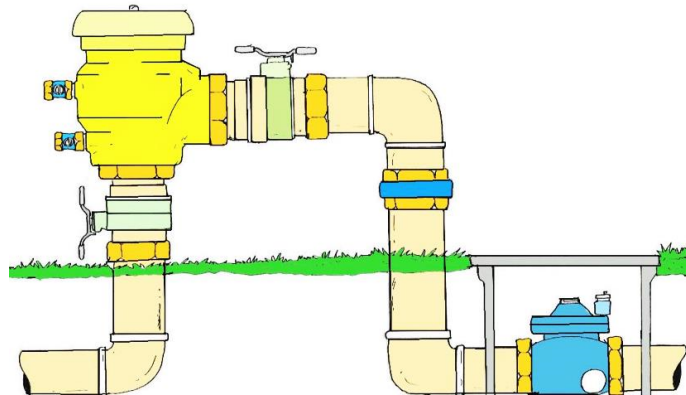

## Double Check Valve Assembly (DC)

The Double Check Valve Assembly consists of two internally loaded check valves, either spring loaded or internally weighted, two resilient seated full ported shutoff valves, and four properly located resilient seated test cocks. This assembly shall be installed as a unit as shipped by the manufacturer. The double check valve assembly is designed to prevent backflow caused by backpressure and backsiphonage from low health hazards or pollutional concerns only. The double check valve should be installed in an accessible location and protected from freezing. The DC needs to be installed 12 inches above the ground for testing purposes only.

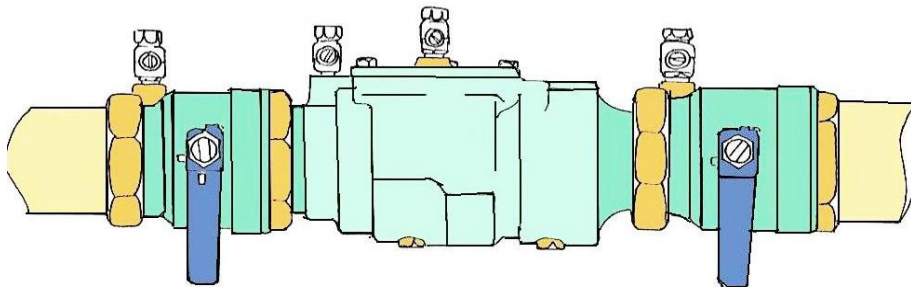

DOUBLE CHECK VALVE ASSEMBLY

## Reduced Pressure Backflow Assembly (RP)

The reduced pressure backflow assembly consists of two independently acting spring loaded check valves separated by a spring loaded differential pressure relief valve, two resilient seated full ported shutoff valves, and four properly located resilient seated test cocks. This assembly shall be installed as a unit shipped by the manufacturer.

During normal operation, the pressure between the two check valves, referred to as the zone of reduced pressure, is maintained at a lower pressure than the supply pressure. If either check valve leaks, the differential pressure relief valve maintains a differential pressure of at least two (2) psi between the supply pressure and the zone between the two check valves by discharging water to atmosphere.

The reduced pressure backflow assembly is designed to prevent backflow caused by backpressure and backsiphonage from low to high health hazards. The RP needs to be installed 12 inches above the ground for testing purposes only.



Two brand new RPs.

## Different Types of RPs

The RP consists of two internally loaded (weighted or spring loaded) check valves separated by a reduced pressure zone with a relief port to vent water to the atmosphere.

The reduced pressure device can be used for high hazard situations under both backpressure and backsiphonage conditions. Under normal conditions, the second check valve should prevent backflow.

However, if the second check valve fails or becomes fouled and backflow into the reduced pressure zone occurs, the relief port vents the backflow to atmosphere.

The reduced pressure zone port opens anytime pressure in the zone comes within 2 psi of the supply pressure.

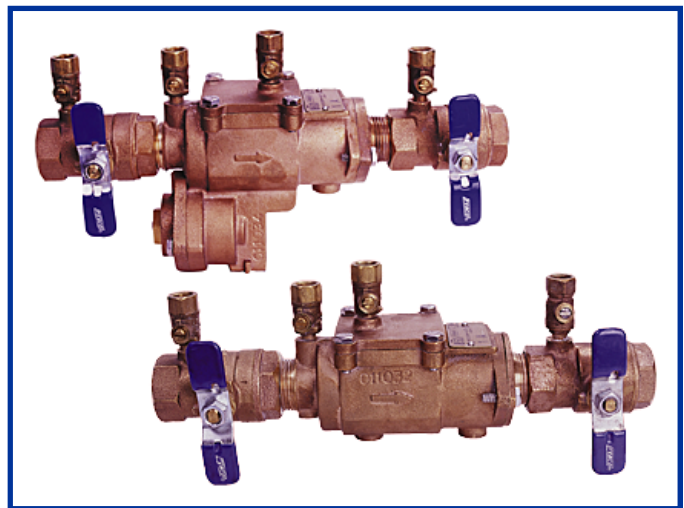
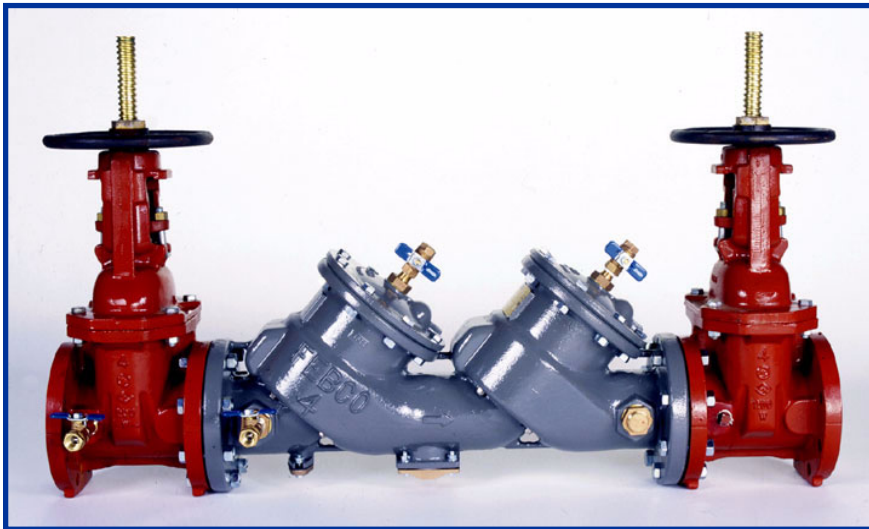



# Backflow Responsibility

## The Public Water Purveyor

The primary responsibility of the water purveyor is to develop and maintain a program to prevent or control contamination from water sources of lesser quality or other contamination sources from entering into the public water system.

Under the provisions of the Safe Drinking Water Act of 1974, (SDWA) and current Groundwater Protection rules the Federal Government through the EPA, (Environmental Protection Agency), national standards of safe drinking water. The separate states are responsible for the enforcement of these standards as well as the supervision of public water systems and the sources of drinking water.

The water purveyor (or supplier) is held responsible for compliance to the provisions of the Safe Drinking Water Act, to provide a warranty that water quality by their operation is in conformance with the EPA standards at the source, and is delivered to the customer without the quality being compromised as its delivery through the distribution system.

**Code of Federal Regulations (Volume 40, Para. 141.2 Section c)”:** Maximum contaminant level means the permissible level of a contaminant in water which is delivered to the free flowing outlet of the ultimate user of a public water system, except in the case of turbidity where the maximum permissible level is measured at the point of entry (POE) to the distribution system.

Contaminants added to the water under circumstances controlled by the user, except those resulting from corrosion of piping and plumbing caused by water quality, are excluded from this definition.

## The Water Consumer

Has the responsibility to prevent contaminants from entering into the public water system by way of their individual plumbing system, and retain the expenses of installation, maintenance, and testing of the approved backflow prevention assemblies installed on their individual water service line.

## The Certified General Backflow Tester

Has the responsibility to test, maintain, inspect, repair, and report/notify on approved backflow prevention assemblies as authorized by the persons that have jurisdiction over those assemblies.



### **Why do water suppliers need to control cross-connections and protect their public water systems against backflow?**

Backflow into a public water system can pollute or contaminate the water in that system (i.e., backflow into a public water system can make the water in that system unusable or unsafe to drink), and each water supplier has a responsibility to provide water that is usable and safe to drink under all foreseeable circumstances.

Furthermore, consumers generally have absolute faith that water delivered to them through a public water system is always safe to drink. For these reasons, each water supplier must take reasonable precautions to protect its public water system against backflow.

### **What should water suppliers do to control cross-connections and protect their public water systems against backflow?**

Water suppliers usually do not have the authority or capability to repeatedly inspect every consumer's premises for cross-connections and backflow protection. Alternatively, each water supplier should ensure that a proper backflow preventer is installed and maintained at the water service connection to each system or premises that poses a significant hazard to the public water system.

Generally, this would include the water service connection to each dedicated fire protection system or irrigation piping system and the water service connection to each of the following types of premises:

- (1) premises with an auxiliary or reclaimed water system;
- (2) industrial, medical, laboratory, marine or other facilities where objectionable substances are handled in a way that could cause pollution or contamination of the public water system;
- (3) premises exempt from the State Plumbing Code and premises where an internal backflow preventer required under the State Plumbing Code is not properly installed or maintained;
- (4) classified or restricted facilities; and
- (5) tall buildings.

Each water supplier should also ensure that a proper backflow preventer is installed and maintained at each water loading station owned or operated by the water supplier.

### **What is a backflow preventer?**

A backflow preventer is a means or mechanism to prevent backflow. The basic means of preventing backflow is an air gap, which either eliminates a cross-connection or provides a barrier to backflow. The basic mechanism for preventing backflow is a mechanical backflow preventer, which provides a physical barrier to backflow.

The principal types of mechanical backflow preventer are the reduced-pressure principle assembly, the pressure vacuum breaker assembly, and the double check valve assembly. A secondary type of mechanical backflow preventer is the residential dual check valve.

## Degrees of Hazards (HAZARD RATINGS)

High, or Contaminant

Low, or Pollutinal

### **CONTAINMENT PROTECTION *Secondary protection***

This approach utilizes a minimum of backflow devices and isolates the customer from the water main. It virtually insulates the customer from potentially contaminating or polluting the public water supply system.

Containment protection does not protect the customer within his own building, but it does effectively remove him from the possibility of public water supply contamination.

Containment protection is usually a backflow prevention device as close as possible to the customer's water meter and is often referred to as "Secondary Protection".

This type of backflow protection is excellent for water purveyors and is the least expense to the water customer, but does not protect the occupants of the building.

### **INTERNAL PROTECTION, *Primary protection***

The water purveyor may elect to protect his customers on a domestic internal protective basis and/or "fixture outlet protective basis"--in this case, cross-connection-control devices (backflow preventors) are placed at internal hazard locations and at all locations where cross-connections may exist including the "*last free flowing outlet.*"

This type of protection entails extensive cross-connection survey work usually performed by a plumbing inspector or a Cross-Connection Specialist.

In a large water supply system, internal protection in itself is virtually impossible to achieve and police due to the quantity of systems involved, the complexity of the plumbing systems inherent in many industrial sites, and the fact that many plumbing changes are made within commercial establishments that do not get the plumbing department's approval or require that the water department inspects when the work is completed.

Internal protection is the most expensive and best type of backflow protection for both the water purveyor and the customer alike, but is very difficult to maintain.

In order for the purveyor to provide maximum protection of the water distribution system, consideration should be given to requiring the owner of the premises to provide, at his own expense, adequate proof that his internal water supply system complies with the local or state plumbing code(s). In addition, he may be required to install, test, and/or maintain all backflow protection assemblies.

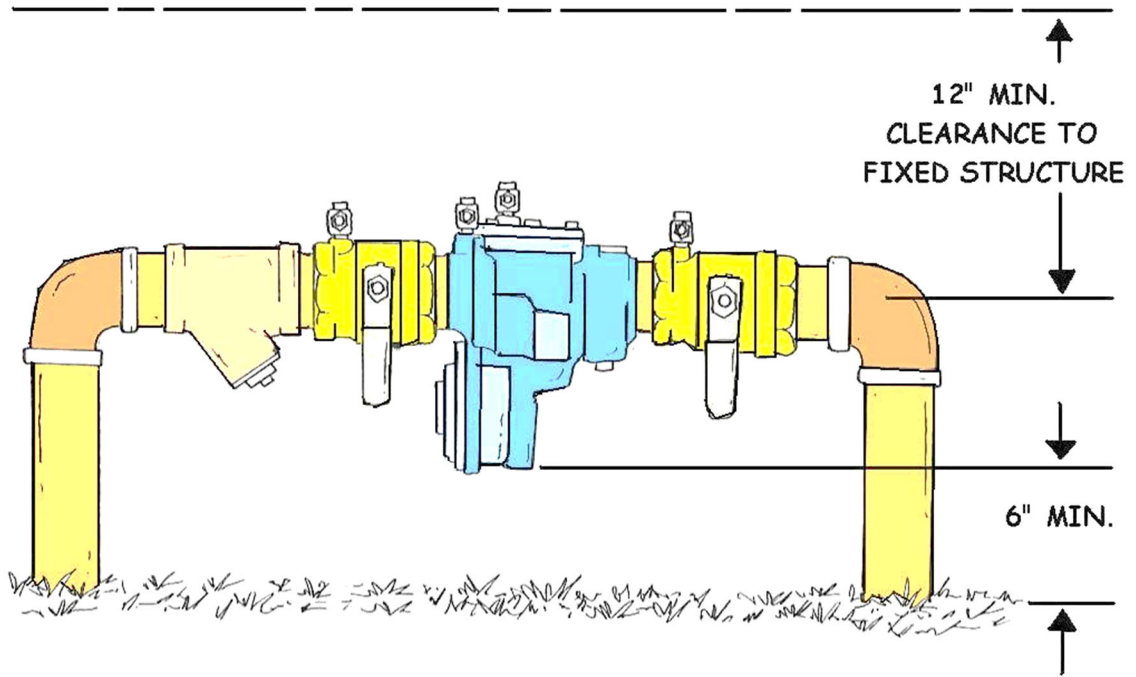

**STANDARD INSTALLATION DETAIL**

## Residential Dual Check Valve (rdc)

An RDC is similar to a DC in that it is a mechanical backflow preventer consisting of two independently acting, spring-loaded check valves. However, it usually does not include shutoff valves, may or may not be equipped with test cocks or ports, and is generally less reliable than a DC.

An RDC is effective against backpressure backflow and backsiphonage but should be used to isolate only non-health hazards and is intended for use only in water service connections to single-family homes.

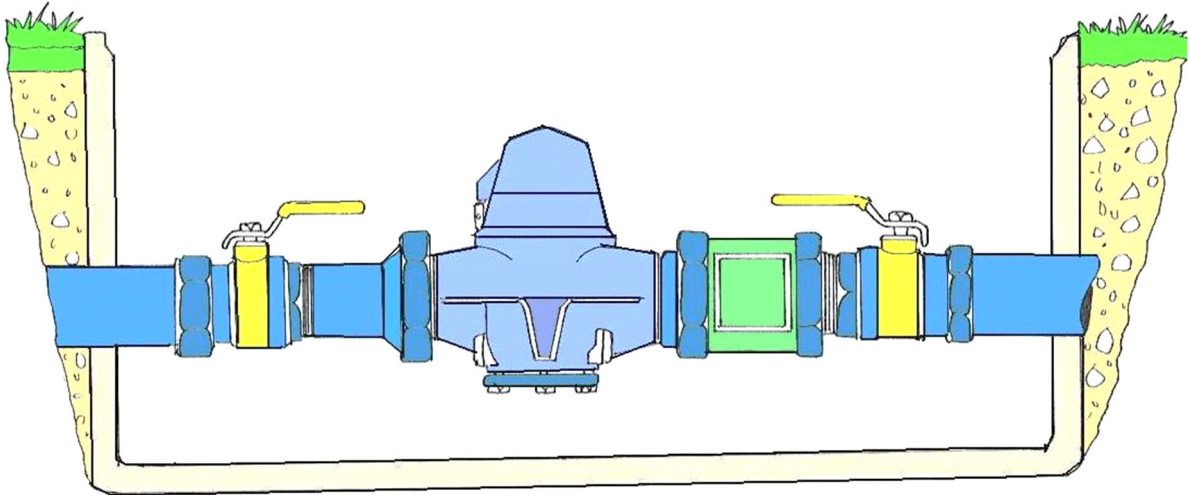

### RESIDENTIAL DUAL CHECK VALVE INSTALLATION AT THE METER

Typical Dual Check installation at the water meter Febco 810

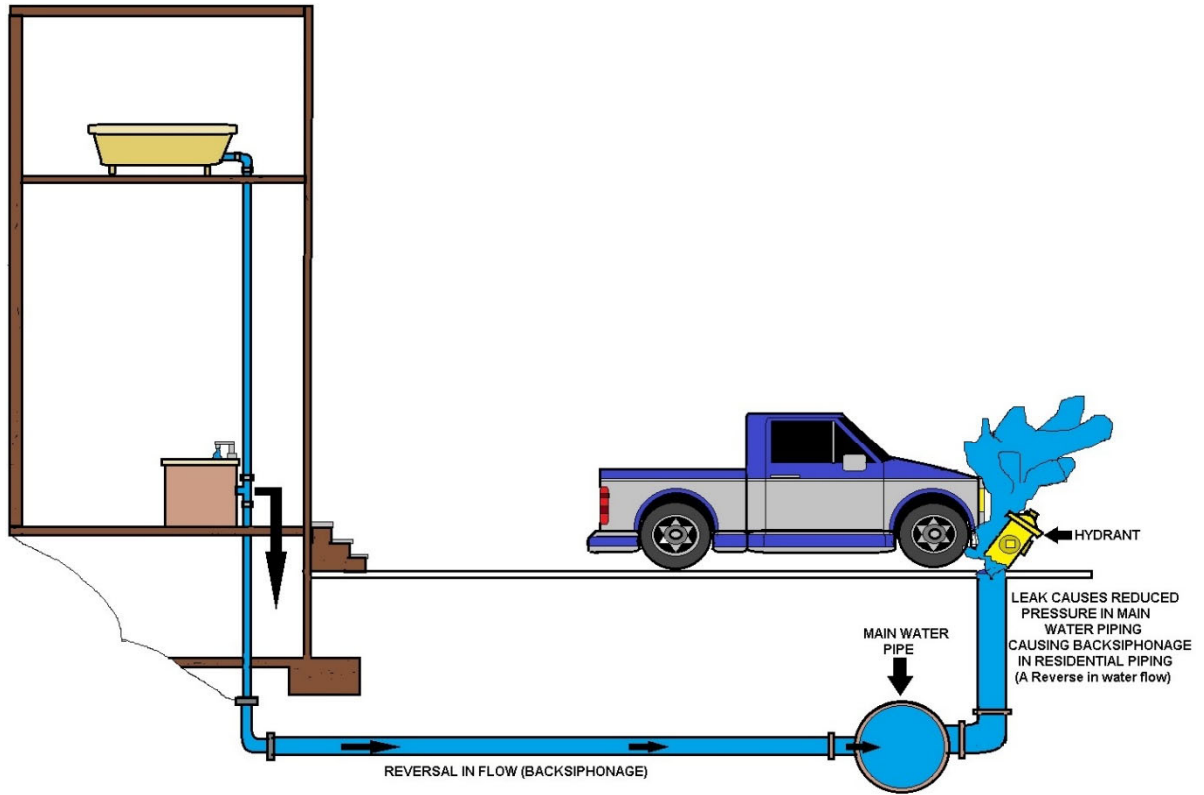

## BACKSIPHONAGE

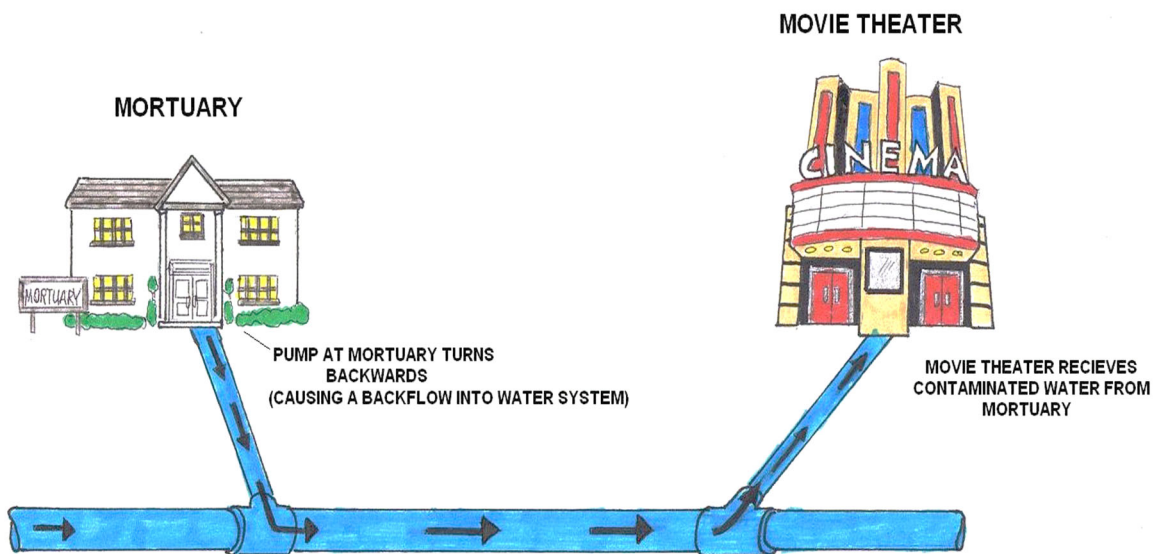

## Why do Backflow Preventors have to be Tested periodically?

Mechanical backflow preventors have internal seals, springs, and moving parts that are subject to fouling, wear, or fatigue. Also, mechanical backflow preventors and air gaps can be bypassed. Therefore, all backflow preventors have to be tested periodically to ensure that they are functioning properly. A visual check of air gaps is sufficient, but mechanical backflow preventors have to be tested with properly calibrated gauge equipment.

Backflow prevention devices must be tested annually to ensure that they work properly. It is usually the responsibility of the property owner to have this test done and to make sure that a copy of the test report is sent to the Public Works Department or Water Purveyor.

If a device is not tested annually, Public Works or the Water Purveyor will notify the property owner, asking them to comply. If the property owner does not voluntarily test their device, the City may be forced to turn off water service to that property. State law requires the City to discontinue water service until testing is complete.



Leaky RP, probably has some debris in the pressure differential area or in the hydraulic relief valve area.



If you ever need to prove for a need for backflow protection, visit your local fair grounds or trailer park. I guarantee that you'll find all the cross-connection you need at the concession stand and most health departments and plumbing officials could care less. Here is a photograph of a drinking water and sewer connection in the same meter box with the sewer backing up. The white hose is for drinking water and it is back siphoning the sewage water, the sheen is a reflection of the water pulsating in and out of the meter box.

**What is backflow? Reverse flow condition.**

Backflow is the undesirable reversal of flow of nonpotable water or other substances through a cross-connection and into the piping of a public water system or consumer's potable water system. There are two types of backflow--**backpressure** and **backsiphonage**.



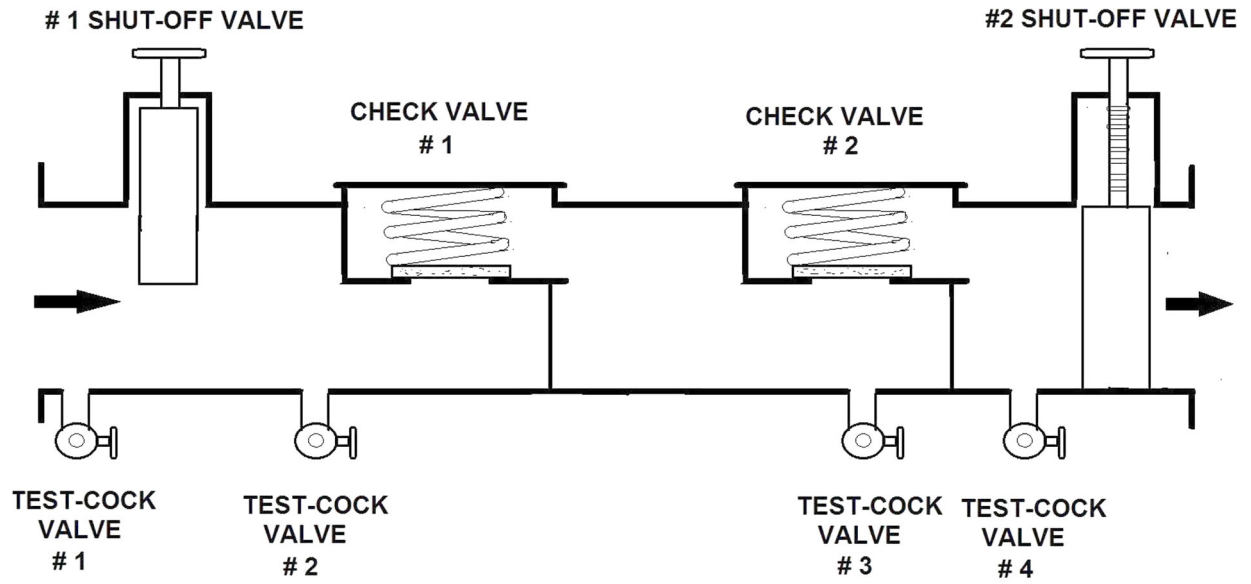

**DOUBLE-CHECK INTERNAL VIEW**

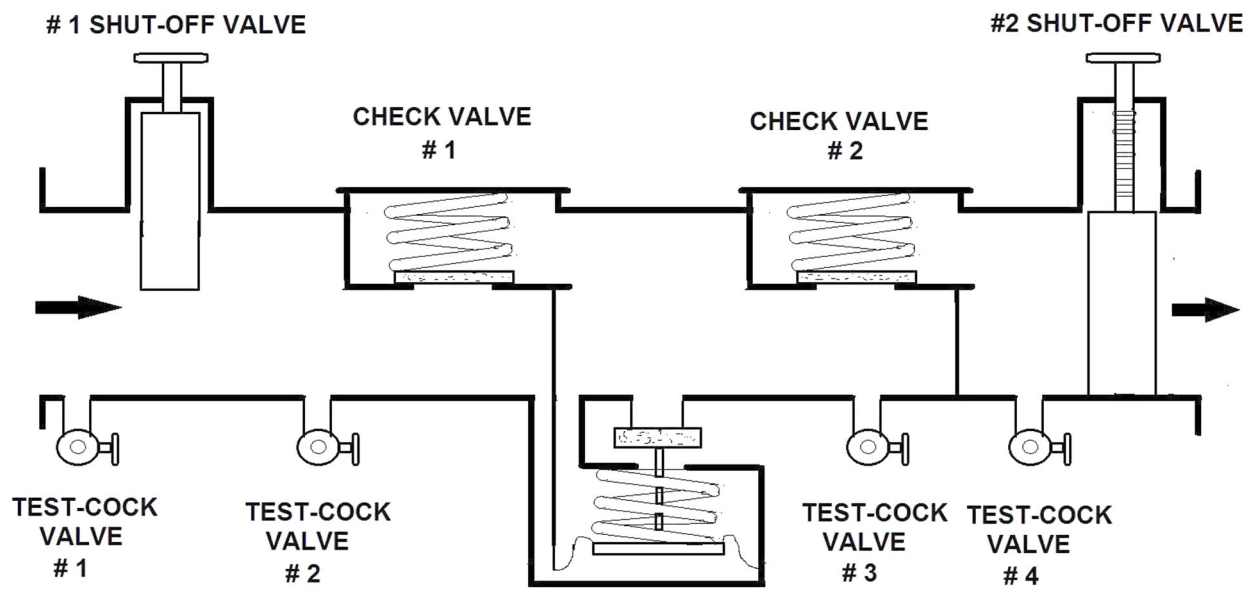

**REDUCED PRESSURE PRINCIPLE ASSEMBLY INTERNAL VIEW**

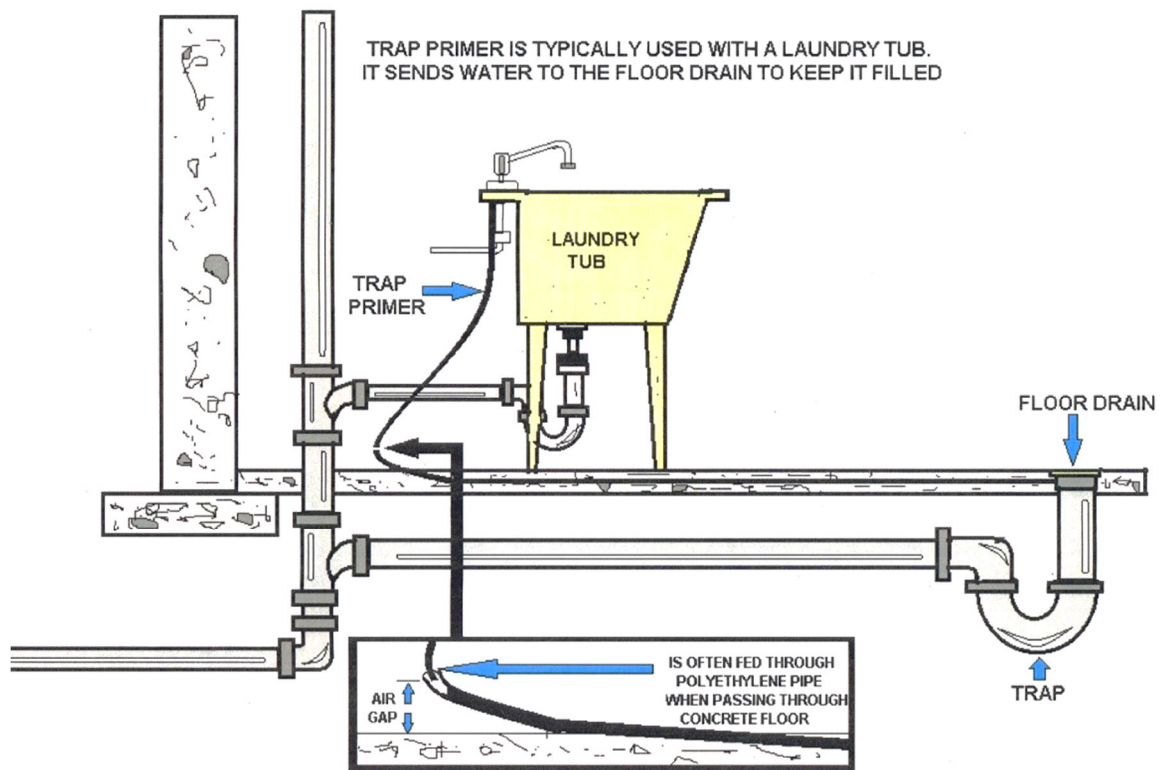
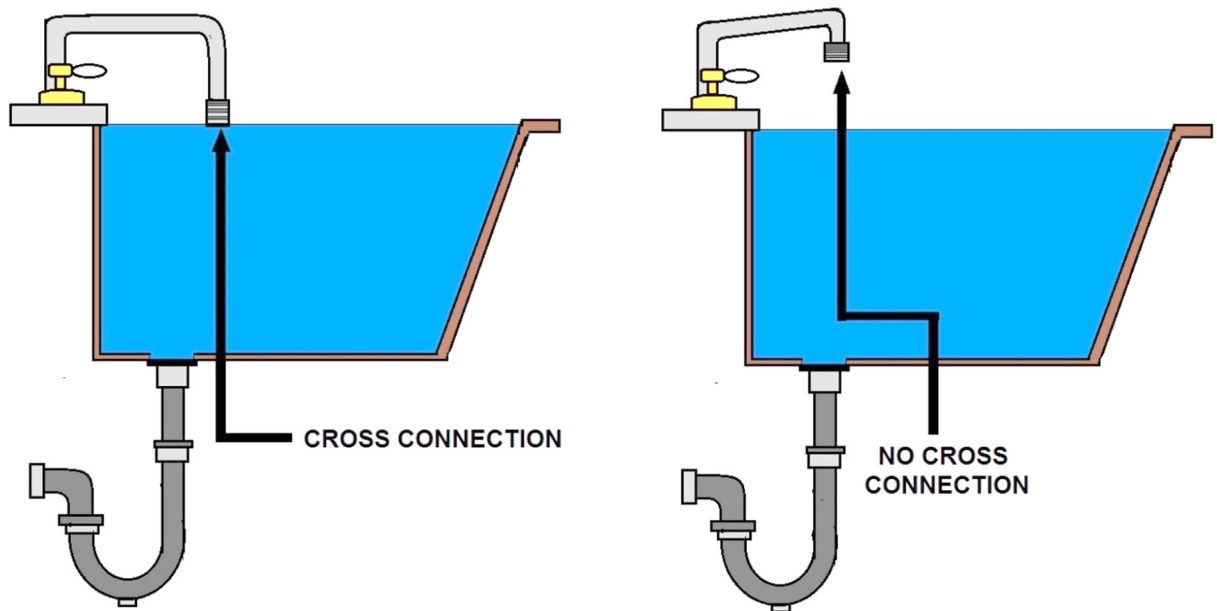

**TRAP PRIMER DIAGRAM**

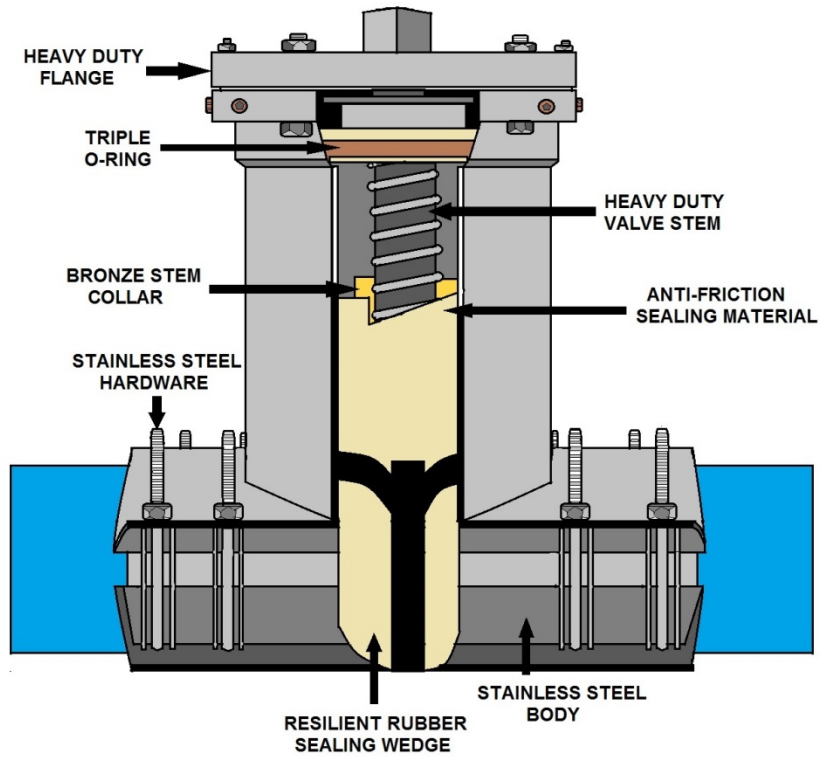

## INSTA-VALVE

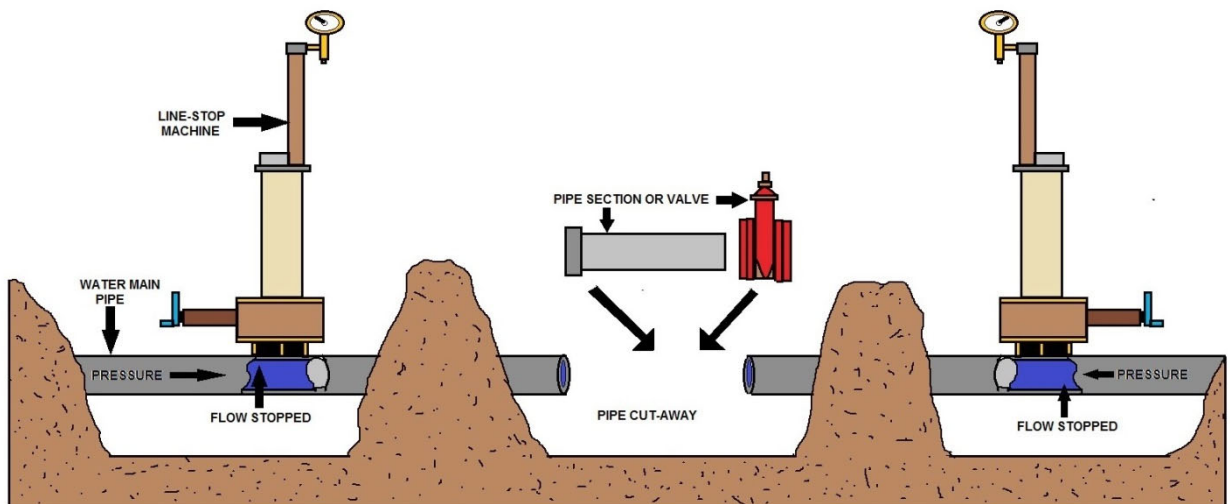

## INSERTION VALVE

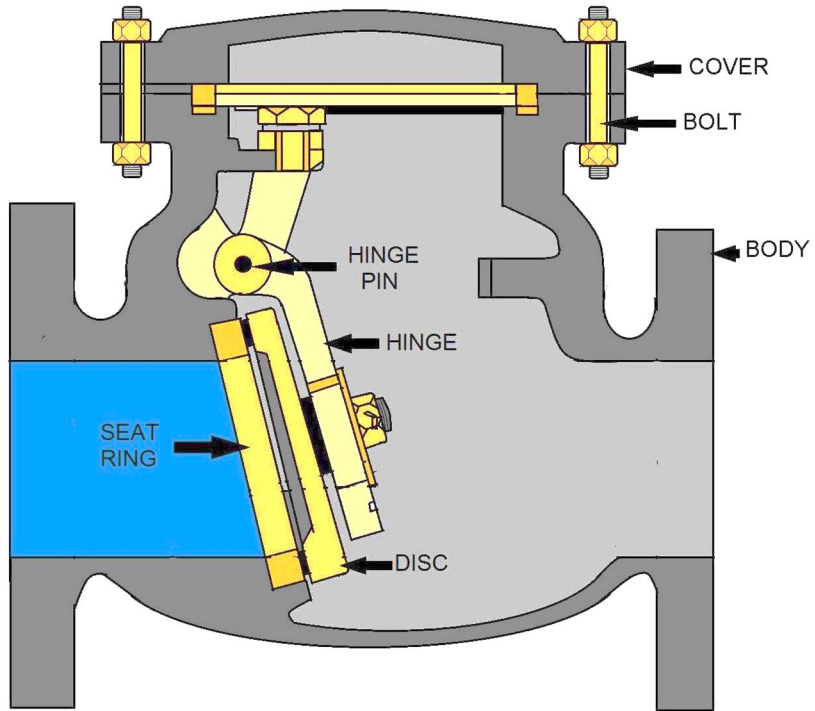

**CHECK VALVE EXAMPLE**

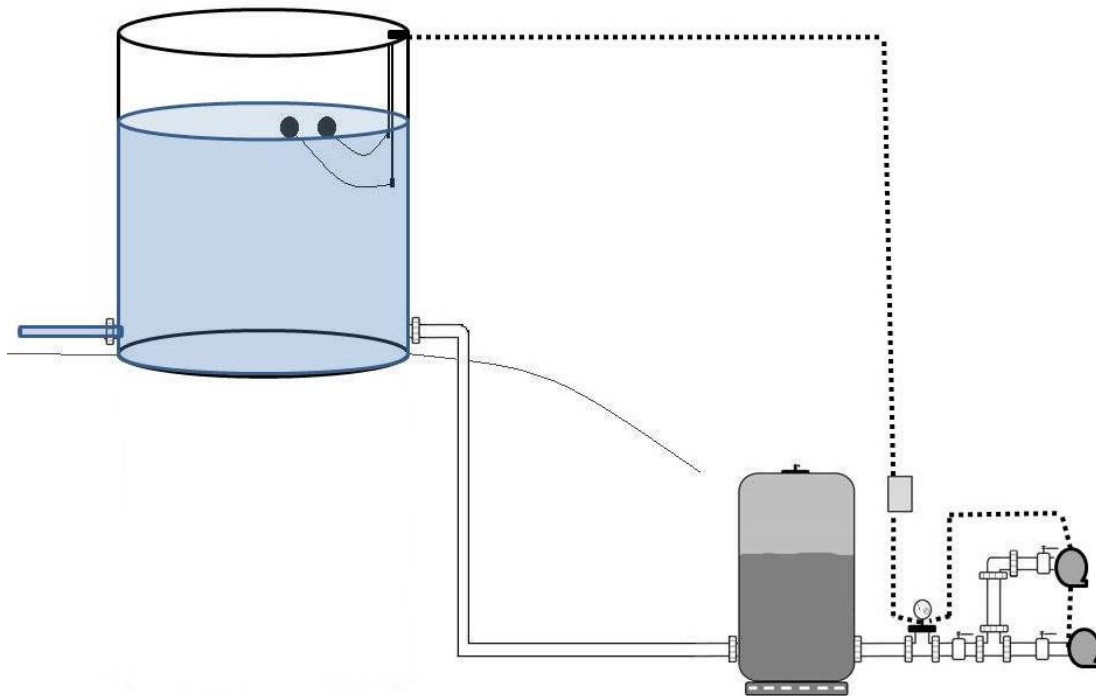

**HYDROPNEUMATIC & STORAGE TANK EXAMPLE**

## Pathogens - Chapter 4

### Pathogens

Bacteria, viruses and protozoans that cause disease are known as pathogens. Most pathogens are generally associated with diseases that cause intestinal illness and affect people in a relatively short amount of time, generally a few days to two weeks. They can cause illness through exposure to small quantities of contaminated water or food or from direct contact with infected people or animals.

### How Diseases are Transmitted

Pathogens that may cause waterborne outbreaks through drinking water have one thing in common: they are spread by the fecal-oral, or feces-to-mouth, route.

Pathogens may get into water and spread when infected humans or animals pass the bacteria, viruses and protozoa in their stool. For another person to become infected, he or she must take that pathogen in through the mouth.

Waterborne pathogens are different from other types of pathogens such as the viruses that cause influenza (the flu) or the bacteria that cause tuberculosis. Influenza virus and tuberculosis bacteria are spread by secretions that are coughed or sneezed into the air by an infected person.

Human or animal wastes in watersheds, failing septic systems, failing sewage treatment plants or cross-connections of water lines with sewage lines provide the potential for contaminating water with pathogens. The water may not appear to be contaminated because feces has been broken up, dispersed and diluted into microscopic particles. These particles, containing pathogens, may remain in the water and be passed to humans or animals unless adequately treated.

Only proper treatment will ensure eliminating the spread of disease. In addition to water, other methods exist for spreading pathogens by the fecal-oral route. The foodborne route is one of the more common methods. A frequent source is a food handler who does not wash his hands after a bowel movement and then handles food with “*unclean*” hands. The individual who eats feces-contaminated food may become infected and ill. It is interesting to note the majority of foodborne diseases occur in the home, not restaurants.

Day care centers are another common source for spreading pathogens by the fecal-oral route. Here, infected children in diapers may get feces on their fingers, then put their fingers in a friend’s mouth or handle toys that other children put into their mouths.

The general public and some of the medical community usually refer to diarrhea symptoms as “stomach flu.” Technically, influenza is an upper respiratory illness and rarely has diarrhea associated with it; therefore, stomach flu is a misleading description for foodborne or waterborne illnesses, yet is accepted by the general public.

So the next time you get the stomach flu, you may want to think twice about what you’ve digested within the past few days.

### **Chain of Transmission**

Water is contaminated with feces. This contamination may be of human or animal origin. The feces must contain pathogens (disease-causing bacteria, viruses or protozoa). If the human or animal source is not infected with a pathogen, no disease will result.

The pathogens must survive in the water. This depends on the temperature of the water and the length of time the pathogens are in the water. Some pathogens will survive for only a short time in water, others, such as Giardia or Cryptosporidium, may survive for months. The pathogens in the water must enter the water system's intake and in numbers sufficient to infect people. The water is either not treated or inadequately treated for the pathogens present.

A susceptible person must drink the water that contains the pathogen. Illness (disease) will occur. This chain lists the events that must occur for the transmission of disease via drinking water. By breaking the chain at any point, the transmission of disease will be prevented.

### **Bacterial Diseases**

Campylobacteriosis is the most common diarrheal illness caused by bacteria. Symptoms include abdominal pain, malaise, fever, nausea and vomiting; and usually begin three to five days after exposure. The illness is frequently over within two to five days and usually lasts no more than 10 days. Campylobacteriosis outbreaks have most often been associated with food, especially chicken and unpasteurized milk as well as unchlorinated water. These organisms are also an important cause of "travelers' diarrhea." Medical treatment generally is not prescribed for campylobacteriosis because recovery is usually rapid.

Cholera, Legionellosis, salmonellosis, shigellosis, and yersiniosis, are other bacterial diseases that can be transmitted through water. All bacteria in water are readily killed or inactivated with chlorine or other disinfectants.

### **Waterborne Diseases**

The first epidemic of a waterborne disease probably was caused by an infected caveman relieving himself in waters upstream of his neighbors. Perhaps the entire clan was decimated, or maybe the panicky survivors packed up their gourds and fled from the "*evil spirits*" inhabiting their camp to some other place.

As long as people lived in small groups, isolated from each other, such incidents were sporadic. But as civilization progressed, people began clustering into cities. They shared communal water, handled unwashed food, stepped in excrement from casual discharge or spread as manure, used urine for dyes, bleaches, and even as an antiseptic.

As cities became crowded, they also became the nesting places of waterborne, insect borne and skin-to-skin infectious diseases that spurted out unchecked and seemingly at will. Typhus was most common, reported Thomas Sydenham, England's first great physician, who lived in the 17th century and studied early history. Next came typhoid and relapsing fever, plague and other pestilential fever, smallpox and dysentery's-the latter a generic class of disease that includes what's known as dysentery, as well as cholera.

The ancients had no inkling as to the true cause of their misery. People believed divine retribution caused plagues and epidemics, or else bad air, or conjunction of the planets and stars, any and all of these things.

## Hippocrates

Hippocrates, the "Father of Medicine" who lived around 350 B.C., recommended boiling water to filter out impurities - those particles that pollute its sweet taste, mar its clarity or poison the palate.

He was onto something, but his advice pertained only to what the observer could taste, touch, smell or see with the naked eye. The "what you see is what you get" approach was about the extent of scientific water analysis until the late 1800s.

That invisible organisms also thrive and swim around in a watery environment was beyond imagination until a few centuries ago, and their connection with disease wasn't established till a scant 100 years ago. Although the microscope was invented in 1674, it took 200 years more for scientists to discover its use in isolating and identifying specific microbes of particular disease. Only then could public health campaigns and sanitary engineering join forces in eradicating ancient and recurring enteric diseases, at least in developed countries of the world.

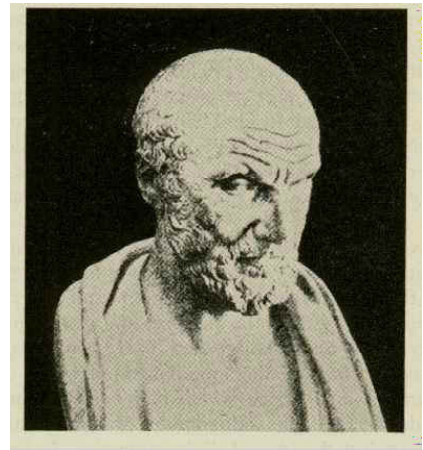

## Cleaning Up

From archeology we learn that various ancient civilizations began to develop rudimentary plumbing. Evidence has turned up of a positive flushing water closet used by the fabled King Minus of Crete back around 1700 B.C.

The Sea Kings of Crete were renowned for their extravagant bathrooms, running hot and cold water systems, and fountains constructed with fabulous jewels and workings of gold and silver.

Just a few months ago, a colorful public latrine dating to the 4th century B.C. was unearthed on the Aegean island of Amorgos.

The 7'x 5' structure resembles a little Greek temple. Topped with a stone roof, the interior walls decorated in red, yellow and green plaster, it served a gymnasium a short distance away. The building accommodated four people seated on two marble benches.

Running water flushed the wastes away, probably along an open ditch at the users' feet.

Ancient water supply and sewerage systems - along with various kinds of luxury plumbing for the nobility - also have been discovered in early centers of civilization such as Carthage, Athens and Jerusalem. But it was the Roman Empire of biblical times that reigns supreme, by historical standards, in cleanliness, sanitation and water supply.

## The Romans

The Romans built huge aqueducts conveying millions of gallons of water daily, magnificent public baths and remarkable sewer systems-one of which, the Cloaca Maxima, is still in use. Rome spread its plumbing technology throughout many of its far-flung territories as well.

Yet, while we may rightfully marvel at the Roman legacy in plumbing, it should be noted that they were motivated by concerns of esthetics, comfort and convenience. They understood very well that bringing fresh water to the masses and disposing of waste made for a more pleasant way of life, but there is little evidence they understood the connection with disease control.

Bursting Rome's Bubble: In fact, the magnificence great city-state diminishes quite a bit when its plumbing systems come under closer scrutiny. Rome sprang up in haphazard fashion, a town of crooked, narrow streets and squalid houses. In its heyday, Rome had a population of over one million, and waste disposal was a definite problem.

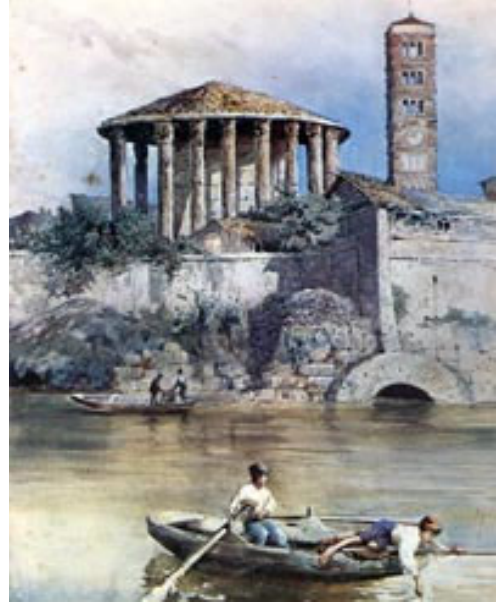

The water supply of Rome was obtained from ground water and rain water, and in many cases these mixed together. The lowlands of the countryside were swampy marshes which developed into malarial wastelands.

The Romans developed underground channels to drain the natural swamps and secure water for irrigation and drinking. Nonetheless, a particular region known as the Pontine Marshes were all but inhabitable during the summertime, until drained during the regime of Benito Mussolini. (Some 40,000 Italians died in a 16th century malaria epidemic.)

A luxury toilet in the private houses of the well-to-do was a small, oblong hole in the floor, without a seat - similar to toilets that prevailed in the Far East and other sections of the world even today. A vertical drain connected the toilet to a cesspool below.

The great Roman spas accommodated hundreds and even thousands of bathers at a time. But without filtration or circulation systems, the bathers basked in germ-ridden water and the huge pools had to be emptied and refilled daily.

In public latrines, a communal bucket of salt water stood close by in which rested a long stick with a sponge tied to one end. The user would cleanse his person with the spongy end and return the stick to the water for the next one to use.

The stick later evolved into the shape of a hockey stick, and the source for the expression **"getting hold of the wrong end of the stick."** It also provided an excellent medium for passing along bacteria and the assorted diseases they engendered.



One of the characteristic Imperial Roman building types is the giant bath complex which could house not only bathing facilities but lecture halls, gymnasia, libraries and gardens. Roman bathing establishments usually provided three kinds of baths, i.e., hot, tepid and cold. The room pictured above was kept warm by hot air circulating through pipes in the walls and floor.



**Examples of Roman water pipe and Latrine and below is a hand washing station.**



Running water for the latrine either was supplied by stone water tanks or else by an aqueduct patterned after the graceful, curved arches made famous by the Roman engineers. Those water experts knew that covering water keeps it cool from the sun and helps prevent the spread of algae.

Imperfect though their plumbing knowledge may have been, the Roman Empire still did an admirable job assuring public cleanliness and, inadvertently, health.

Rome employed administrators known as aediles to oversee various public works, including coliseum games and the police. They also were in charge of seeing that streets got swept of garbage and streams cleared of visible pollution and debris.



Lead pipes that carried both hot and cold water under pressure were in use in Rome over 4,000 years ago and can be clearly seen in the ancient city of Pompeii. Below is a steam vent that was used in a bath house over 5,000 years ago.



## **Decline & Fall**

Though the Roman Empire would last until the 6th century A.D., its fall was preceded by centuries of gradual decay, conflict and unrest. Ironically, some historians suggest that the Roman *plumberi* (plumbers) may have played a significant role in the downfall due to their extensive use of lead.

## **Plumberi**

So prized was the craftsmanship of these *plumberi* that, in lieu of present-day status symbols like a Rolls Royce or Porsche, our Roman ancestors boasted of lead pipes in their houses, especially those imprinted with the plumber's name (usually female, by the way), and that of the building owner.

## **Lead Poisoning**

Lead poisoning is at least a plausible explanation for the dementia of Roman emperors such as Caligula and Nero, and for a general weakening and demoralization of the populace at large. However, the case for massive lead poisoning is far from proven, and water piping was hardly the only source of lead contamination. The widespread use of lead cooking utensils and goblets probably was more harmful than its use in plumbing.

Whatever the causes, over time there was a noticeable deterioration in the moral values, dignity and physical character of Roman society. Symbolic of this general decline, by the time of Augustus Caesar in 14 A.D., the once authoritative aediles collected the waste only at state-sponsored events.

During the final century of Roman domination, there was a succession of earthquakes, volcanic eruptions and disease epidemics. Soon afterwards, rampaging Vandals and other barbaric tribes completed the breakdown of Western civilization, as they systematically leveled and defiled the great Roman cities and their water systems.

## **Medieval Squalor**

Then came a thousand years of medieval squalor. A thousand years of sicknesses and plague of unbridled virulence, fanned by fleas and mosquitoes, excrement and filth, stagnant and contaminated water of every description.

## **Age Of Disease**

The typical peasant family of the aptly-named Dark Ages lived in a one-room, dirt-floor hovel, with a hole in the thatched roof to let out the smoke of the central fire.

The floor was strewn with hay or rushes, easy havens for lice and vermin. Garbage accumulated within. If they were lucky, the family had a chamber pot, though it was more likely they relieved themselves in the corner of the hovel or in the mire and muck outside.

Water was too precious to use for anything except drinking and cooking, so people rarely bathed. Heck, they barely changed clothes from one season to another, wearing the same set every day, perhaps piling on more rags for warmth.



This fountain inside a bathhouse in Pompeii had brass fittings to carry the water under pressure to create a fountain in the center for washing your hands. This sink was solid alabaster and was engineered for this application. There is an inscription on the basin that explains the cost and the person that purchased the basin for the bath house.

## Black Plague

These are the conditions which spawned the infamous Black Plague, killing an estimated one third of the European population. Although not directly related to bad plumbing, the plague serves as the most striking example of misery caused by poor sanitation in general, and the ignorance of people in controlling the outbreak.

The first of several waves hit England in 1348, caused by flea bites spread by lice that dwelt on host black rats. They, in turn, fed on the garbage and excrement of the masses. London became largely deserted. The King and Queen and other rich people fled to the countryside. The poor were the greatest sufferers.

Panic, death and despair followed the abandonment of farms and towns. Wrote William of Dene, a monk of Rochester in Kent, England, "Men and women carried their own children on their shoulders to the church and threw them into a common pit. From these pits such an appalling stench was given off that scarcely anyone dared to walk beside the cemeteries, so marked a deficiency of labors and workmen that more than a third of the land in the whole realm was left to."

So bad was the "*Black Death*," the Great Fire of London in 1666 can be viewed as a blessing in disguise. Though it killed thousands of people, the holocaust also consumed garbage, muck and black rats, effectively ending the plague.

### Dysentery

Bad plumbing was merely one of many sanitation factors that gave rise to the Black Death. Other scourges are more directly related to human waste. Dysentery is one that has left an indelible mark on history.

Characterized by painful diarrhea, dysentery is often called an army's "*fifth column*." Identified as far back as the time of Hippocrates and before, it comes in various forms of infectious disorders and is said to have contributed to the defeat of the Crusaders. Wrote the eminent English historian, Charles Creighton: "*The Crusaders of the 11th - 13th centuries were not defeated so much by the scimitars of the Saracens as by the hostile bacteria of dysentery and other epidemics.*"

The summer of the first Crusade in 1090 was extraordinarily hot as the ill-prepared and rag-tag "**army**" of men and camp followers went to war with little more than the clothes on their backs-confident that the Lord would provide for their needs in such a holy cause. They denuded the land of trees and bushes in the quest for nourishment.

Hampered by lack of fresh water and contaminated containers, they trudged along to their destiny, relieving themselves along the wayside or in the fields.

Dysentery hit the women and children first, and then the troops. More than 100,000 died plus almost 2,500 German reinforcements whose bodies remained unburied.

## Typhus Fever

Typhus fever is another disease born of bad sanitation. It has come under many headings, including "jail fever" or "ship fever," because it is so common among men in pent-up, putrid surroundings. Transmitted by lice that dwell in human feces, the disease is highly contagious.

Napoleon lost thousands of his men to typhus in Russia - as did the Russians who caught it from the enemy. Many historians believe that Napoleon would have won were it not for the might of his opponents "*General Winter, General Famine and General Typhus.*"

French ships were notorious for their filthy and fever-ridden sailors. One such French squadron left its soiled clothing and blankets behind near Halifax, Nova Scotia, when they returned to Europe in 1746, thinking they could dispel their own plague. Their infected blankets wiped out a nation of Indians.



Typhoid fever, a slightly different ailment than typhus, involves a Salmonella bacillus that is found in the feces and urine of man. The symptoms are so similar to typhus that the two were not differentiated until 1837. Prince Albert died from typhoid in 1861.

His wife, Queen Victoria, had built-in in-immunity because of a previous siege. Good thing, because she is said to have prostrated herself in grief across the dead body of her beloved husband.

Ten years later, Victoria's son, Edward, almost died from the disease. A plumber traced the contamination to the lines of a newly-installed water closet and fixed the problem. Edward, the Prince of Wales, was very grateful to the plumber. Word spread of this episode and is thought to have hastened the acceptance of the indoor water closet in England.

By the time of the Boer War in 1899-1901, anti-typhoid inoculation was available. By then, typhoid fever was recognized as a waterborne disease, and that the germ could be killed by filtering and boiling water. Far from home in South Africa, the undisciplined British troops succumbed to the hot climate and drank straight from the rivers. Of 400,000 troops, 43,000 contracted typhoid.

Closer to home, typhoid raged on in colonial New York and Massachusetts. It reappeared for the last time in epidemic form in America in the early 1900s, compliments of the celebrated Typhoid Mary.

## Typhoid Mary

Mary Maflon was a cook for the moneyed set of New York State; her specialty was homemade ice cream. Officially, she infected 53 people - with three deaths - before she was tracked down. Unofficially, she is blamed for some 1,400 cases that occurred in 1903 in Ithaca, where she worked for several families. Never sick herself, it took a lot of persuasion by authorities to convince her that she was a carrier of the disease. Health authorities quarantined her once, let her go, and then quarantined her for the rest of her life when another outbreak occurred.



## **The Cholera Story**

The bad news is that another waterborne disease, cholera, has proven one of history's most virulent killers. The good news is that it was through cholera epidemics that epidemiologists finally discovered the link between sanitation and public health, which provided the impetus for modern water and sewage systems.

With 20th - century smugness, we know cholera is caused by ingesting water, food or any other material contaminated by the feces of a cholera victim. Casual contact with a contaminated chamber pot, soiled clothing or bedding, etc., might be all that's required.

The disease is stunning in its rapidity. The onset of extreme diarrhea, sharp muscular cramps, vomiting and fever, and then death - all can transpire within 12-48 hours.

In the 19th century cholera became the world's first truly global disease in a series of epidemics that proved to be a watershed for the history of plumbing.

Festering along the Ganges River in India for centuries, the disease broke out in Calcutta in 1817 with grand - scale results.

India's traditional, great Kumbh festival at Hardwar in the Upper Ganges triggered the outbreak. The festival lasts three months, drawing pilgrims from all over the country. Those from the Lower Bengal brought the disease with them as they shared the polluted water of the Ganges and the open, crowded camps on its banks.

When the festival was over, they carried cholera back to their homes in other parts of India. There is no reliable evidence of how many Indians perished during that epidemic, but the British army counted 10,000 fatalities among its imperial troops. Based on those numbers, it's almost certain that at least hundreds of thousands of natives must have fallen victim across that vast land.

When the festival ended, cholera raged along the trade routes to Iran, Baku and Astrakhan and up the Volga into Russia, where merchants gathered for the great autumn fair in Nijni-Novgorod. When the merchants went back to their homes in inner Russia and Europe, the disease went along with them.

Cholera sailed from port to port, the germ making headway in contaminated kegs of water or in the excrement of infected victims, and transmitted by travelers. The world was getting smaller thanks to steam-powered trains and ships, but living conditions were slow to improve. By 1827 cholera had become the most feared disease of the century.

It struck so suddenly a man could be in good health at daybreak and be buried at nightfall. A New Yorker in 1832 described himself pitching forward in the street *"as if knocked down with an ax. I had no premonition at all."* The ailment seemed capable of penetrating any quarantine of harbor or city. It chose its victims erratically, with terrifying suddenness, and with gross and grotesque results. Acute dehydration turns victims into wizened caricatures their former selves. The skin becomes black and blue, the hands and feet drawn and puckered.

The German poet Heinrich Heine described an outbreak in Paris in a letter to a friend: *"A masked ball in progress ... suddenly the gayest of the harlequins collapsed, cold in the limbs, and underneath his mask, violet blue in the face."*

*Laughter died out, dancing ceased and in a short while carriage-loads of people hurried from the Hotel Dieu to die, and to prevent a panic among the patients were thrust into rude graves in their dominoes [long, hooded capes worn with a half-mask]. Soon the public halls were filled with dead bodies, sewed in sacks for want of coffins ... long lines of hearses stood in queue..."*

### **Industrial Revolution**

The worldwide cholera epidemic was aided by the Industrial Revolution and the accompanying growth of urban tenements and slums. There was little or no provision at all for cesspools or fresh water supplies.

Tenements rose several stories high, but cesspools were only on the ground floor with no clear access to sewers or indoor running water. It didn't make much difference, because until the 1840s a sewer was simply an elongated cesspool with an overflow at one end.

"Night men" had to climb into the morass and shovel the filth and mire out by hand. In most cases, barrels filled with excrement were discharged outside, or contents of chamber pots flung from open windows - if there were any - to the streets below.

Water hydrants or street pumps provided the only source of water, but they opened infrequently and not always as scheduled. They ran only a few minutes a day in some of the poor districts. A near riot ensued in Westminster one Sunday when a water pipe that supplied 16 packed houses was turned on for only five minutes that week.

### **Cholera**

Cholera first hit England through the town of Sunderland, on October 26, 1831. One William Sproat died that day from the disease, though nobody wanted to admit it. Merchants and officials found plenty of reasons to rationalize away a prospective 40 day maritime quarantine of the ports.

England was reaping the profits of the Industrial Revolution. and a quarantine of ships would be catastrophic for the textile industry. At any rate, the medical profession held that cholera wasn't contagious.

Public health administration was in its infancy, and so disorganized that the leading doctor didn't know there were two infected houses only a short distance away from each other. He learned of the "coincidence" three months later.

### **North America**

American hygiene and sanitation were not much better. Cholera spread through immigrants from the infected countries, Ireland in particular, whose masses were fleeing the poverty and despair of the potato famine. Those who could scrape together three pounds for passage left for North America. Life aboard an immigrant ship was appalling, as ship owners crowded 500 passengers in space intended for 150. Infected passengers shared slop buckets and rancid water.

The contagion spread as soon as the immigrants landed. In one month, 1,220 new arrivals were dead in Montreal. Another 2,200 died in Quebec over the summer of 1832.



Detroit became another focal point of cholera. Instead of drawing fresh water from the Detroit River, people used well water. The land was low and it was much more convenient. But outhouses placed at odd locations soon contaminated those wells, and cholera spread quickly.

Cholera entered New York through infected ships. City people started clogging the roads in an exit to the countryside. On June 29, 1832, the governor ordered a day of fasting and prayers - the traditional response by government to treating the disease. After July 4, there was a daily cholera report.

### **Epidemic**

Quarantine regulations which sought to contain towns and cities in upper New York, Vermont and along the Erie Canal met with little success. Immigrants leaped from halted canal boats and passed through locks on foot, despite the efforts by contingents of armed militia to stop them.

Some doctors flatly declared that cholera was indeed epidemic in New York, but more people sided with banker John Pintard that this "*official report*" was an "*impertinent interference*" with the Board of Health.

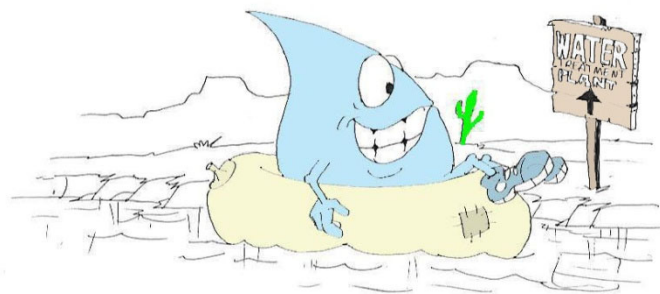

The banker incredulously asked if the physicians had any idea what such an announcement would do to the city's business.

Visitors were struck by the silence of New York's streets, with their unaccustomed cleanliness and the fact they were strewn with chloride of lime (the usual remedy for foul-smelling garbage). Even on Broadway, passersby were so few that a man on horseback was a curiosity. One young woman recalled seeing tufts of grass growing in the little-used thoroughfares. Big news was unfolding in England then, but no one realized the significance.



## Dr. John Snow

The eminent Dr. John Snow demonstrated how cases of cholera that broke out in a district of central London could all be traced to a single source of contaminated drinking water. Sixteen years later Snow would win a 30,000 franc prize from the Institute of France for his theory that cholera was waterborne and taken into the system by mouth.

But Snow's original work received little attention from the medical profession. He was attacked at the weakest point - that he could not identify the nature of the "**poison**" in the water.

By the end of the first cholera epidemic, the relationship between disease and dirty, ill-drained parts of town was rather well established. This should have spurred sanitary reform. But little action followed.

An out-of-sight, out-of-mind syndrome developed when the first epidemic ended. The learned Edinburgh Medical and Surgical Journal at one point declared they would review no more books on the subject "*because of the multitude of books which have recently issued from the press on the subject of cholera, and our determination to no longer try the patience of our readers.*"



When the second cholera epidemic hit England in 1854, Snow described it as "*the most terrible outbreak of cholera which ever occurred in this kingdom.*" At least it provided him with an opportunity to test his theory.

By charting the incidence of the disease, he showed that over 500 cases occurred within 10 days over a radius of some 250 yards centered on London's Broad Street. He looked for some poison which he believed came from the excreta of cholera patients and was swallowed by the new victims. A common factor was their use of water that had been polluted with sewage. Snow had traced the pipelines of various water companies and showed that one was infected by cholera.

By the methodical process of elimination, he proved his point: A workhouse in that area had its own private well, and there were only 5 deaths among its 535 inmates. A brewery on Broad Street likewise never used the water from the Broad Street pump, and it had no cases among its 70 workers.

### Discovery

The actual discovery of the comma-shaped bacillus of cholera was made by the German Dr. Robert Koch in 1876. Through microscopic examination, "*he ascertained that excrement may contain cholera bacteria a good while after the actual attack of the disease.*"

### Final Obstacles

Cholera was always the worst where poor drainage and human contact came together. This, of course, was apt to be in crowded slums.

So at first, those on top of the social heap could reassure themselves that pestilence attacked only the filthy, the hungry and the ignorant. When the cholera epidemic first hit Paris, there

were so few deaths outside of the lower classes that the poor regarded the cholera epidemic as a poison plot hatched by the aristocracy and executed by the doctors.

In Milwaukee, efforts to apply basic health measures were thwarted by rag-pickers and "*swill children*" who saw the removal of offal and garbage from the streets as a threat to their livelihood. As one newspaper editorialized, "It is a great pity if our stomachs must suffer to save the noses of the rich."

The immunity enjoyed by the wealthy was short-lived, however. The open sewers of the poor sections eventually leached into the ground and seeped into wells, or ran along channels into the rivers that supplied drinking water for whole towns and cities. Once the rich and the movers and shakers of society began to get sick, government reform began.

Thus it happened that most municipal water mains and sewer systems were built in the late 19th century in America. Public health agencies were formed and funded. Building codes and ordinances were passed and enforced.

The superstitions of the ages had finally run their course. Mankind began to understand that the evil spirits causing its woes were microscopic creatures that could be defeated by plumbers and sanitary engineers.

Plumbers finally got to show their stuff in a way that had not been seen since the days of the Roman Empire.



Here is a public water fountain in downtown Rome still in operation from the time of Caesar. Something to think about, He revolutionized government.

## **Viral-Caused Diseases**

Hepatitis A is an example of a common viral disease that may be transmitted through water. The onset is usually abrupt with fever, malaise, loss of appetite, nausea and abdominal discomfort, followed within a few days by jaundice. The disease varies in severity from a mild illness lasting one to two weeks, to a severely disabling disease lasting several months (rare).

The incubation period is 15-50 days and averages 28-30 days. Hepatitis A outbreaks have been related to fecally contaminated water; food contaminated by infected food handlers, including sandwiches and salads that are not cooked or are handled after cooking; and raw or undercooked mollusks harvested from contaminated waters. Aseptic meningitis, polio and viral gastroenteritis (Norwalk agent) are other viral diseases that can be transmitted through water. Most viruses in drinking water can be inactivated by chlorine or other disinfectants.

## **Protozoan Caused Diseases**

Protozoan pathogens are larger than bacteria and viruses but still microscopic. They invade and inhabit the gastrointestinal tract. Some parasites enter the environment in a dormant form, with a protective cell wall, called a "cyst." The cyst can survive in the environment for long periods of time and is extremely resistant to conventional disinfectants such as chlorine. Effective filtration treatment is therefore critical to removing these organisms from water sources.

### **Giardiasis**

Giardiasis is a commonly reported protozoan-caused disease. It has also been referred to as "*backpackers disease*" and "*beaver fever*" because of the many cases reported among hikers and others who consume untreated surface water. Symptoms include chronic diarrhea, abdominal cramps, bloating, frequent loose and pale greasy stools, fatigue and weight loss. The incubation period is 5-25 days or longer, with an average of 7-10 days.

### **Giardia lamblia**

Many infections are asymptomatic (no symptoms). Giardiasis occurs worldwide. Waterborne outbreaks in the United States occur most often in communities receiving their drinking water from streams or rivers without adequate disinfection or a filtration system.

The organism, *Giardia lamblia*, has been responsible for more community-wide outbreaks of disease in the U.S. than any other pathogen. Drugs are available for treatment but are not 100% effective.

Cryptosporidiosis is an example of a protozoan disease that is common worldwide but was only recently recognized as causing human disease. The major symptom in humans is diarrhea, which may be profuse and watery. The diarrhea is associated with cramping abdominal pain. General malaise, fever, anorexia, nausea and vomiting occur less often.

Symptoms usually come and go, and end in fewer than 30 days in most cases. The incubation period is 1-12 days, with an average of about seven days.

***Cryptosporidium*** organisms have been identified in human fecal specimens from more than 50 countries on six continents. The mode of transmission is fecal-oral, either by person-to-person or animal-to-person. There is no specific treatment for *Cryptosporidium* infections.

### **Diarrhea**

All of these diseases, with the exception of hepatitis A, have one symptom in common: diarrhea. They also have the same mode of transmission, fecal-oral, whether through person-to-person or animal-to-person contact, and the same routes of transmission, being either foodborne or waterborne. Although most pathogens cause mild, self-limiting disease, on occasion, they can cause serious, even life threatening illness.

Particularly vulnerable are persons with weak immune systems such as those with HIV infections or cancer.

By understanding the nature of waterborne diseases, the importance of properly constructed, operated and maintained public water systems becomes obvious. While water treatment cannot achieve sterile water (no microorganisms), the goal of treatment must clearly be to produce drinking water that is as pathogen-free as possible at all times.

For those who operate water systems with inadequate source protection or treatment facilities, the potential risk of a waterborne disease outbreak is real. For those operating systems that currently provide adequate source protection and treatment, operating and maintaining the system at a high level on a continuing basis is critical to prevent disease.

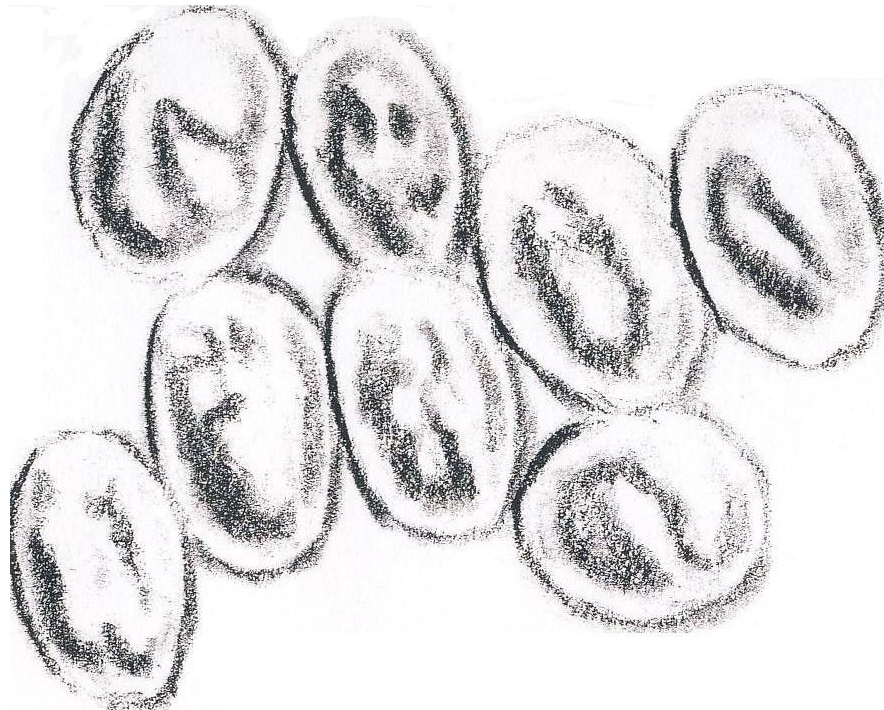



**Cryptosporidium**

## Waterborne Diseases

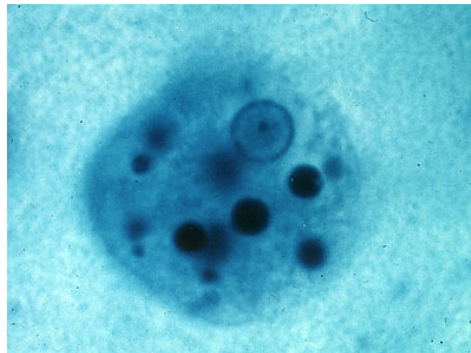
<b>Name</b>	<b>Causative organism</b>	<b>Source of organism</b>	<b>Disease</b>
Viral gastroenteritis	Rotavirus (mostly in young children):	Human feces;	Diarrhea or vomiting
Norwalk-like viruses:	Human feces; also, shellfish;	lives in polluted waters;	Diarrhea and vomiting
Salmonellosis	<b>Salmonella:</b> (bacterium)	Animal or human feces.	Diarrhea or vomiting
Gastroenteritis	Escherichia coli-- <b>E. coli O1 57:H7:</b> (bacterium); Other <i>E. coli</i> organisms;	Human feces;	symptoms vary with type caused
Typhoid	<b>Salmonella typhi</b> (bacterium):	Human feces, urine;	Inflamed intestine, enlarged spleen, high temperature— sometimes fatal.
Shigellosis	<b>Shigella</b> (bacterium):	Human feces.	Diarrhea
Cholera	<b>Vibrio choleras</b> (bacterium)	Human feces; also, shellfish;	lives in many coastal waters; Vomiting, severe diarrhea, rapid dehydration, mineral loss —high mortality.
<b>Hepatitis A</b> virus	Human feces; shellfish grown in polluted waters;		Yellowed skin, enlarged liver, fever, vomiting, weight loss, abdominal pain — low mortality, lasts up to four months.
Amebiasis	<b>Entamoeba histolytica</b> (protozoan):	Human feces;	Mild diarrhea, dysentery, extra intestinal infection
Giardiasis	<b>Giardia lamblia</b> (protozoan):	Animal or human feces.	Diarrhea, cramps, nausea, and general weakness — lasts one week to months.
Cryptosporidiosis	<b>Cryptosporidium parvum:</b>	Animal or human feces.	Diarrhea, stomach pain — lasts (protozoan) days to weeks.

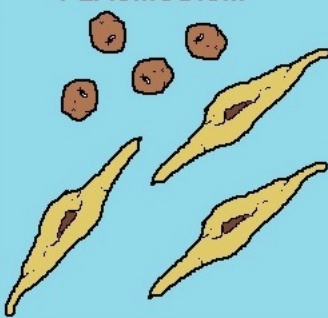

Entamoeba histolytica

PHYLUM	COMMON NAME	LOCOMOTION	EXAMPLES
SARCODINA	SARCODINES	<u>PSEUDOPODIA</u>	AMOEBA 
CILIOPHORA	CILIATES	<u>CILIA</u>	PARAMECIUM 
SARCO- MASTIGOPHORA (ZOOMASTIGINA)	ZOOFLAGELLATES	<u>FLAGELLA</u>	TRYPANOSMA GIARDIA 
APICOMPLEXA (SPOROZOA)	SPOROZOANS	<u>NONE IN ADULT FORM</u>	PLASMODIUM 

## PROTOZOA CLASSIFICATION

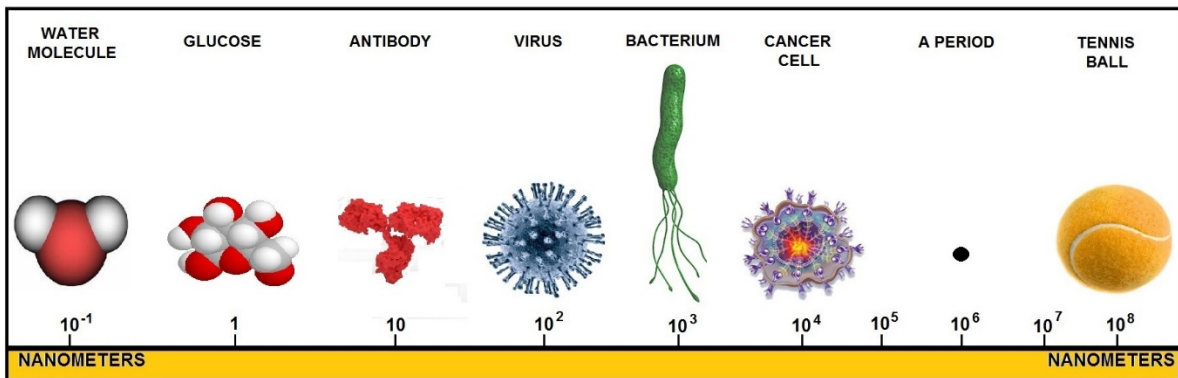

SIZE COMPARISON  
HOW SMALL IS SMALL ?



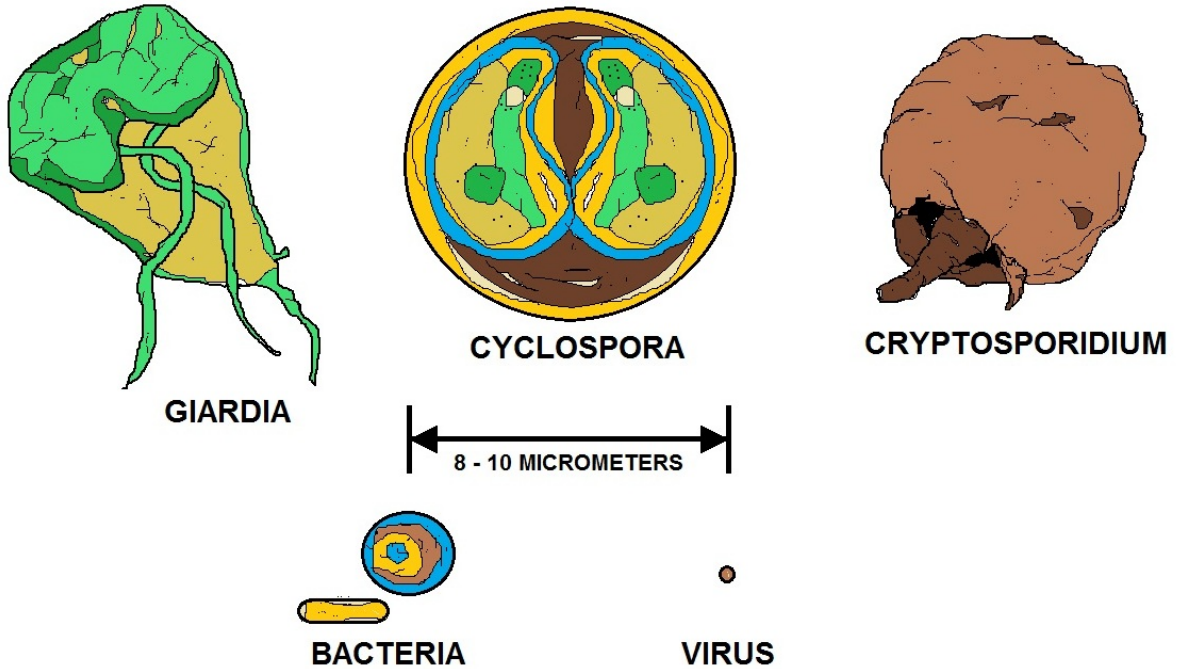

## COMPARATIVE SIZES OF PROTOZOAN PARASITES

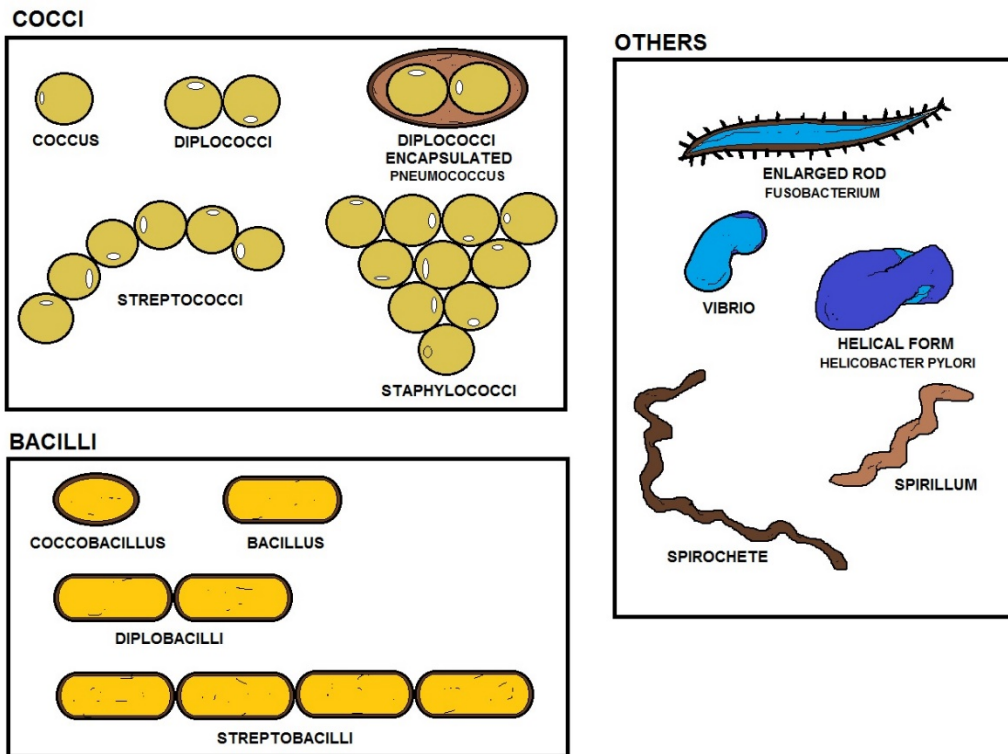

## THE DIFFERENT SHAPES OF BACTERIA



2-Way Cleanout DWV Soil Pipe, needs to be within 2 feet of the house, perpendicular (not parallel) to the footing and the end or grade level needs to be painted to protect from sunlight.



Sewer lateral going into a manhole.

## Plumbing Fittings - Chapter 5

Copper is a popular material for water supply line. It's durable pipe that handles high water pressure loads and is relatively easy to work with.

However, copper is expensive and may cost up to three times more than plastic CPVC (chlorinated polyvinyl chloride) pipe.

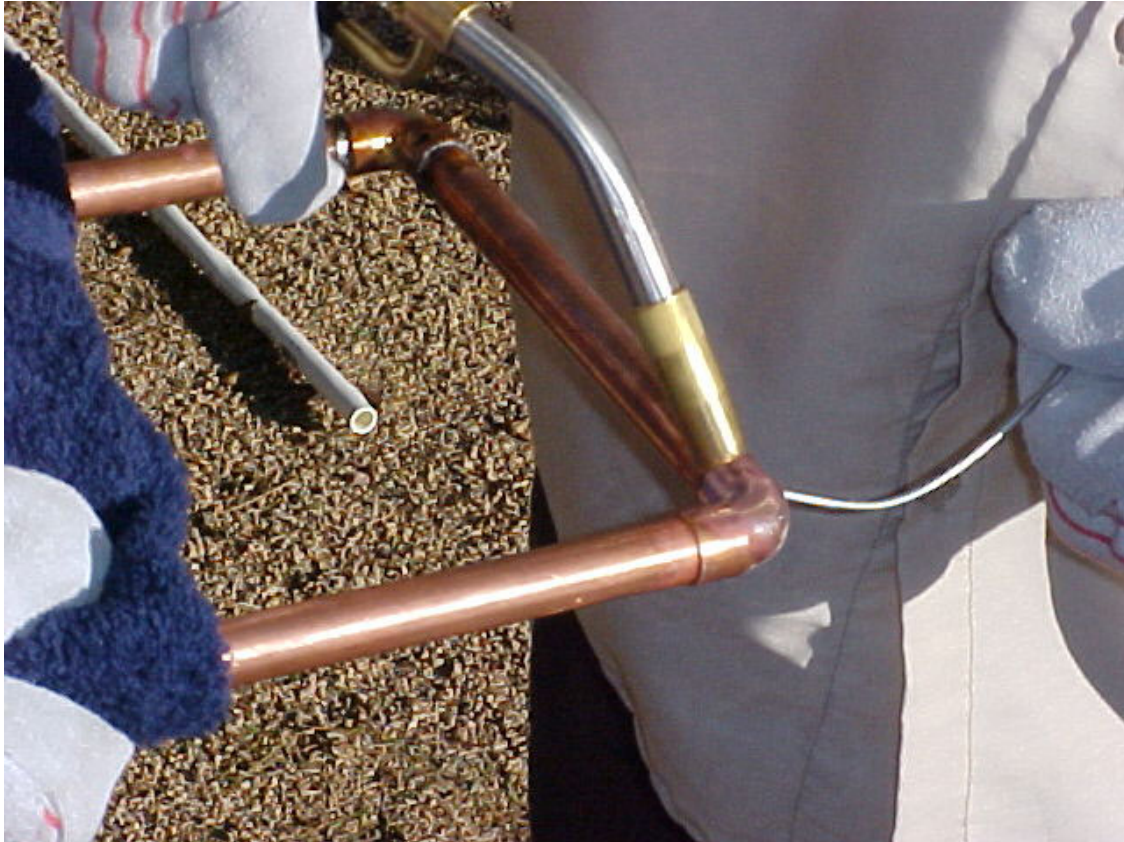

Soldering pipe, there are several types of copper pipe. Soft and rigid, K-Green, L-Blue, M-Red, and DWV-yellow. You can no longer use lead solder for potable water. Copper lines fit together with lead-free, solid-core solder. The soldering process involves heating the pipe and is commonly called "sweating."



Lavatory or bathroom set-up with a Dirty Arm and possible water softener loop.

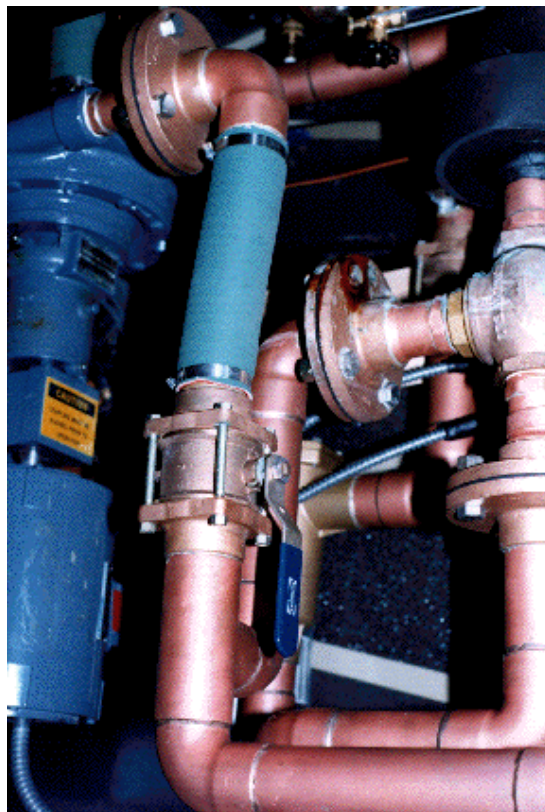

Various copper fittings. I predict that we will no longer see copper fittings utilized in plumbing by the year 2020. The price of copper is going sky high.

## Plastic Pipe and Fittings

Proper solvent cementing techniques are fundamental to successful installation. The following techniques provide the basis for strong and durable solvent cement joints.

Considering that the majority of piping installation failures are the result of improper cementing techniques, an understanding of the proper techniques required for joining saves both time and money. A quality solvent cement joint furnishes strength to the entire system. Likewise, no system is fully effective when even a single joint is poorly cemented. Obviously, a fair amount of time devoted to preparation will pay off upon completion.

The first step in solvent cementing consists of inspecting the pipe and fittings for overall appearance and compatibility. Obvious defects such as cracks, burrs and incompatible materials must be addressed as required. The joining surfaces must be clean and dry. In addition, the proper cement for the type and size of pipe and fittings should be determined.

Also, remember both temperature and humidity may be issues to consider. Another detail that is often overlooked is the need to have the correct size applicator for the size of pipe. The general rule is to have an applicator about half the size of the pipe diameter in order to assure proper and timely solvent cement coverage.

Next, proper technique requires that the pipe be cut square with a fine-toothed saw or tube cutters. The use of ratcheting cutters, which grip and shear pipe like strong scissors, can generate cracks in the ends of pipe. A square cut promotes proper beveling and full contact between the pipe and the pipe stop in a fitting.

Following the cutting of the pipe, beveling should be accomplished by using a file or a chamfering tool. A slight beveling of 1/16<sup>th</sup> inch removes burrs and debris and promotes the formation of a bead of cement at the base of the socket. While beveling the pipe, one should also clear any debris from the waterway of the pipe and clean the area to be primed. A “*dry fit*” of the pipe and fittings is recommended in order to check for proper fit, depth and alignment.

Moving on to the actual assembly of the components, the first order of business is to apply the appropriate primer. Primer is used to clean, dissolve and penetrate the surfaces of the pipe and fittings. It is important to consider the use of a properly sized applicator, preferably a brush at least one-half the size of the pipe being primed.

The primer should be liberally applied to the fitting socket and to that portion of the pipe, which will fit into the socket. Repeated applications of primer may be required.

Immediately after the application of the primer, the solvent cement should be freely applied to both the fitting and the pipe. Again, not only may repeated applications be required but an appropriately sized applicator should be used. With the surfaces still wet, the pipe should be inserted into the fitting socket with a quarter turn twisting motion, bottoming out the pipe.

The importance of assembling fittings and pipe while the solvent cement is still wet cannot be underestimated. If the job requires it, two people should be involved in the priming and cementing process. Finally, the cemented joint should be held together for at least thirty seconds to prevent the parts from separating and the parts should be allowed to set an appropriate period of time before further work or pressurization is attempted.

If the preceding steps are followed, the confidence in the level of durability and strength of the solvent-cemented joints should be very high.



Picture provided by Spears Manufacturing Company

**Tee Slip**



Picture provided by Spears Manufacturing Company

**Reducer Tee**



Picture provided by Spears Manufacturing Company

**90° Reducer Elbow**



Picture provided by Spears Manufacturing Company

**Ball Valve Slip Fitting**



Picture provided by Spears Manufacturing Company

**Flange Butterfly Valve**

## Solvent Cementing Sub-Section

This section was developed to aid the installer in the proper techniques needed for the joining of plastic pipe and fittings.



Solvent Cementing is the most popular kind of CPVC joining method. Remember, always wear eye protection and gloves.

Here are the solvent cementing procedures:

1. Cut the pipe with cutter or saw. Cut the pipe in square to provide optimal bonding area. See the above picture on the right.
2. De-bur the pipe with chamfering tool or file to ensure proper contact between pipe and fitting. Remove all burrs from both the inside and outside of the pipe with a knife, file or reamer. Burrs can scrape channels into pre-softened surfaces or create hang-ups inside surface walls. Remove dirt, grease and moisture. A thorough wipe with a clean dry rag is usually sufficient. (Moisture will retard cure and dirt or grease can prevent adhesion).



3. Apply a heavy, even coat of CPVC primer (if necessary) to the fitting. Remember, Ladies first. Use the right applicator for the size of pipe or fittings being joined. The applicator size should be equal to 1/2 the pipe diameter. It is important that a satisfactory size applicator be used to help ensure that sufficient layers of cement are applied.

**4.** Apply a heavy, even coat of primer (if necessary) to the pipe end. The purpose of a primer is to penetrate and soften the surfaces so they can fuse together. The proper use of a primer and checking its softening effect provides assurance that the surfaces are prepared for fusion in a wide variety of conditions. Check the penetration or softening on a piece of scrap before you start the installation or if the weather changes during the day. Using a knife or other sharp object, drag the edge over the coated surface.

Proper penetration has been made if you can scratch or scrape a few thousandths of the primed surfaces away. Because weather conditions do affect priming and cementing action, repeated applications to either or both surfaces may be necessary. In cold weather, more time is required for proper penetration.



**5.** Apply a heavy, even coat of CPVC cement (if necessary) to the fitting. Remember, Ladies first; then apply to the pipe end. Stir the cement or shake can before using. Using the proper size applicator for the pipe size, aggressively work a full even layer of cement onto the pipe end equal to the depth of the fitting socket -do not brush it out to a thin paint type layer, as this will dry within a few seconds.

**6.** Insert the pipe into the fitting socket, rotating  $\frac{1}{4}$  to  $\frac{1}{2}$  turn. Hold the pipe for 10 seconds, allowing the joint to set-up. A nice thing about plastic pipe is that if you make a mistake, you can cut the section out and re-do it.

**7.** The joining is finished. Cure time depends on pipe size, temperature and relative humidity. If local codes permit, successful joints can be made without a primer using cement alone, but extra care must be given to the installation. It is important that a good interference fit exists between the pipe and fittings. It is for this reason we recommend that joints being made without a primer be limited to systems 2" and smaller for pressure applications (water systems only) or 6" and smaller for DWV or non-pressure applications. Extra care must also be given in applying the cements to make sure proper penetration and softening of the pipe and fitting surfaces is achieved.

**8.** Joint strength develops as the cement dries. In the tight part of the joint the surfaces will tend to fuse together; in the loose part, the cement will bond to both surfaces. These areas must be softened and penetrated. Penetration and softening can be achieved by the cement itself, by using a suitable primer or by the use of both primer and cement. For certain materials and in certain situations, it is necessary to use a primer. A suitable primer will usually penetrate and soften the surfaces more quickly than cement alone.



## Plumbing Fittings

Fittings (faucets and valves) are used more often than any other part of the plumbing system. They get plenty of use but are built to take it, under normal conditions.

The best modern fittings are all chrome plated brass and will last a lifetime under everyday use. They clean easily with soap and warm water.

**Caution:** The metal chromium is easily dissolved in hydrochloric acid and sulfuric acid. Muriatic acid has for years been considered a good tile cleaner, but only where there are nickel plated plumbing fittings. Where chrome plating is present, clean bathroom tile with warm oxalic acid, never with Muriatic or sulfuric acids. Even covering the chromium surfaces with cloths will not prevent the acid fumes from inflicting permanent damage.

Gaining in popularity are polished brass fittings and trim. These will hold up well, as long as certain precautions are observed. NEVER use any abrasive cleaner on polished brass. This can scratch the protective coating on the brass finish resulting in a deterioration or pitting of the brass plating. Also avoid use of solvent based cleaners because they can be deleterious to the polished brass finish.

New technologies have brought about the development of improved finishes that can withstand more wear, but check the manufacturer's warranty to determine whether or not you have the "new and improved" lifetime warranty finish.



Picture provided by Spears Manufacturing Company

Diaphragm Valve with flow indicator.



Picture provided by Spears Manufacturing Company

**Gate Valve**



Picture provided by Spears Manufacturing Company

**Swing Check Valve**



Picture provided by Spears Manufacturing Company

**Three-Way Valve Slip**



Picture provided by Spears Manufacturing Company

**Thread FIP Cap**



Picture provided by Spears Manufacturing Company

**Reducer**



Picture provided by Spears Manufacturing Company

**CTS Drop FIP to Slip 90°**

## Chapter Summary

By understanding the nature of waterborne diseases, the importance of properly constructed, operated and maintained public water systems becomes obvious. While water treatment cannot achieve sterile water (no microorganisms), the goal of treatment must clearly be to produce drinking water that is as pathogen-free as possible at all times.

"Sweating" pipes and plumbing fixtures in summer-time or during seasonal changes are not a sign of faulty plumbing. Due to condensation of water vapor in the air, beads of moisture will form in warm weather on any pipes and fixtures containing cold water.

Normally, when not in use, the water and fixtures will warm rapidly to room temperature and the condensation will stop. When a closet tank or other fixture continues to sweat for hours after it has been used, it is a sign that cold water is continuing to flow through it, possibly due to an improper adjustment of the tank valve or a leak.

Sweating pipes can be wrapped with an insulation material which prevents the condensation and formation of moisture.

There are several types of copper pipe. Soft and rigid, K-Green, L-Blue, M-Red, and DWV-yellow.

You cannot use lead solder for potable water.

Cut plastic pipe to length with a hacksaw, or abrasive disk of a miter saw/chop saw. After each cut, clean out the small burrs/shavings that remain inside the pipe with a knife, rag or emery cloth.



Check small pipes and fittings for plumb/level with a torpedo level. Also, double check the drain flow; about 1/4" per 1' as a general guide.

A fitting that's glued crooked can sometimes throw off the whole run and/or won't fit properly with the next piece. Discover these problems during the dry fit rather than after the pipe is glued.

To glue ABS pipe, check that any cut ends are fairly straight. Remove any burrs with a knife or emery cloth and clean both pieces with a rag. Apply ABS glue to both the pipe and fitting.

Push the joints together with a twisting motion to spread the glue. Hold the joints together for a few seconds so they won't push apart while the fast-drying glue sets.

Gluing PVC pipe is a similar process, but a cleaning chemical (primer) that prepares the plastic goes on before the glue. CPVC pipe also has its own type of glue so be sure to purchase the glue that matches the plastic you're working with. Once the joint is primed, apply the glue to the joints, push and twist the pipe or fitting and hold them in place for a few minutes.

# Plumbing Repairs - Chapter 6

## Faucets

Today, most faucets can be categorized as being washerless (port-type faucets), or of the Compression (washer) type.

## Repairing Faucets

There are a few different types and combinations of faucets: single-handle or two-handled shut-offs that are compression or washerless (cartridge, ball or disc mechanism).



A compression faucet stops water by tightening down a rubber washer to block water flow.

A washerless faucet uses a rotating mechanism -- like a ball or valve -- to open and shut water flow.

A compression faucet usually has threaded brass stems that open/close firmly. A cartridge faucet has brass or plastic valves with holes in them and operate more easily.

## Tips Before You Start

- Close the sink drain to avoid losing any parts.
- After locating the leak, shut off both water supplies before removing any parts.
- Tape wrench jaws to avoid marring the faucet's finish.
- Write down and/or lay out parts to remember their order.
- Buy a repair kit that includes a special adjusting ring wrench, seals, springs and O-rings rather than one or two pieces. Washer assortment kits may also be better than more expensive single washer packaging.
- If the faucet still leaks after installing a kit, the outer housing is probably cracked and buying a new faucet is probably the only way to fix the leak.

## Washerless Faucets

Washerless faucets can be either single handle or the two handle type. In washerless faucets, the control of the water flow is done by a replaceable cartridge or arrangement of seals that allow water flow when the holes or ports are lined up in the proper configuration.

Giving the handle an extra hard twist to stop water flow will be ineffective. This type of faucet does not use compression strength to stop water flow.



Various Seats and Stems. Here is a money maker.

A washer-less faucet does not mean it will never leak, but rather because of the way it is designed, the parts will last much longer, as their design minimizes friction and wear.

When repairing this type of faucet or requesting service on one, it is vital that you know the brand name, or have a sample of the part you require, as there are hundreds of faucet cartridges and parts kits on the market today.

### **Compression Faucets**

Like sink and lavatory faucets, wall mounted faucets fall into two categories: compression and non-compression types. Two-handle compression types feature O-rings and washers that you can replace. The non-compression version usually has a single handle pull-on, push off configuration, with a cartridge assembly beneath, when it leaks, the whole cartridge assembly usually requires replacement.

In a compression type faucet, you will find the conventional setup - a faucet washer on the end of the stem. Replacing the washer usually will correct a dripping faucet.

However, when removing the stem, always check the seat inside the faucet body - the brass ring that the washer grinds against. The faucet seat can be worn or grooved, making the washer replacement ineffective within days. The washer and seat are the two parts of a compression type faucet that receive the greatest amount of wear. It is not difficult to replace a washer. First, shut off the water supply.

Usually, the shut-off valve is under the sink in the kitchen, or in the bathroom, under the lavatory basin. If there is none, shut off the branch-line valve in the basement or the main valve where the water supply enters the house.

Pad a smooth jawed wrench with a cloth, then, using the padded wrench, unscrew the large packing nut and turn out the faucet stem. Then, with a screw driver that fits the screw slot closely, remove the screw from the bottom of the stem and pry out the worn washer. If the screw is tight or stubborn, tap its head lightly or apply penetrating oil (WD-40).

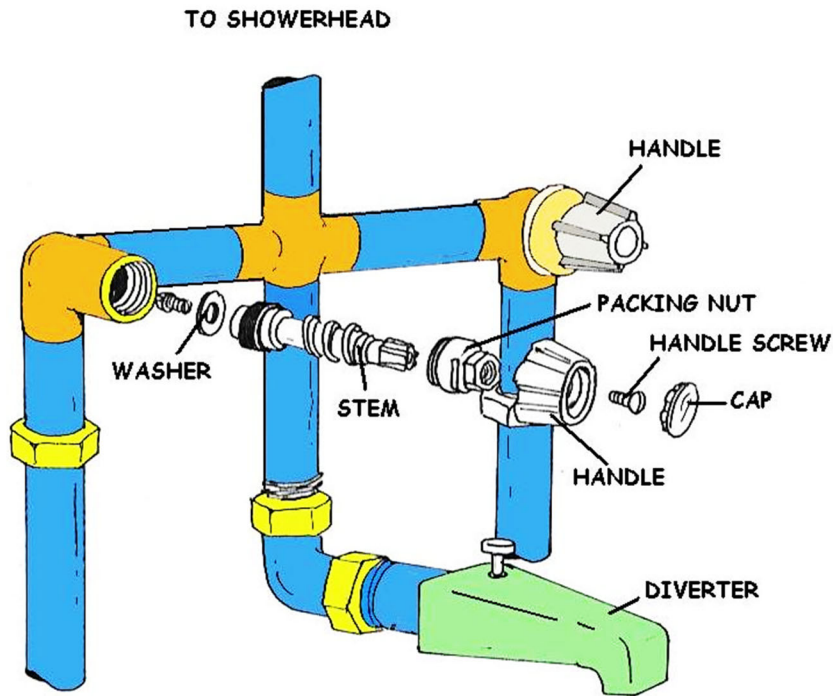

### COMPRESSION TYPE BATHTUB FAUCET

Next, clean out the washer seat or compartment. When this is done, insert the new washer of the correct size and composition for hot or cold water.

Some of the newer, soft neoprene washers are for both hot and cold water and have a long life. The washer should fit snugly without having to be forced into position. After inserting, replace the screw and tighten.



### Worn Faucet

It is usually just as expensive to renew a seat as it is to buy a new faucet, unless it has been made with a renewable seat. Check with your plumbing supply store about a badly worn faucet.

With cloth over finger, clean the valve seat inside the faucet. The edge should be smooth and free from deep nicks. If you find it badly worn, you will probably need to replace the seat or have the entire faucet replaced by the plumber. Otherwise, it will leak again.

Next, replace the faucet stem and turn it in. Tighten the packing nut. Be careful not to tighten the nut more than necessary to stop seepage around the faucet stem.

A faucet leaking 60 drops a minute (not unusual) will waste 2,299 gallons of water every year. Homeowners should repair leaky faucets at once. You pay twice - once for the water going through the meter, and then again on your sewer bill, which is based on water usage.

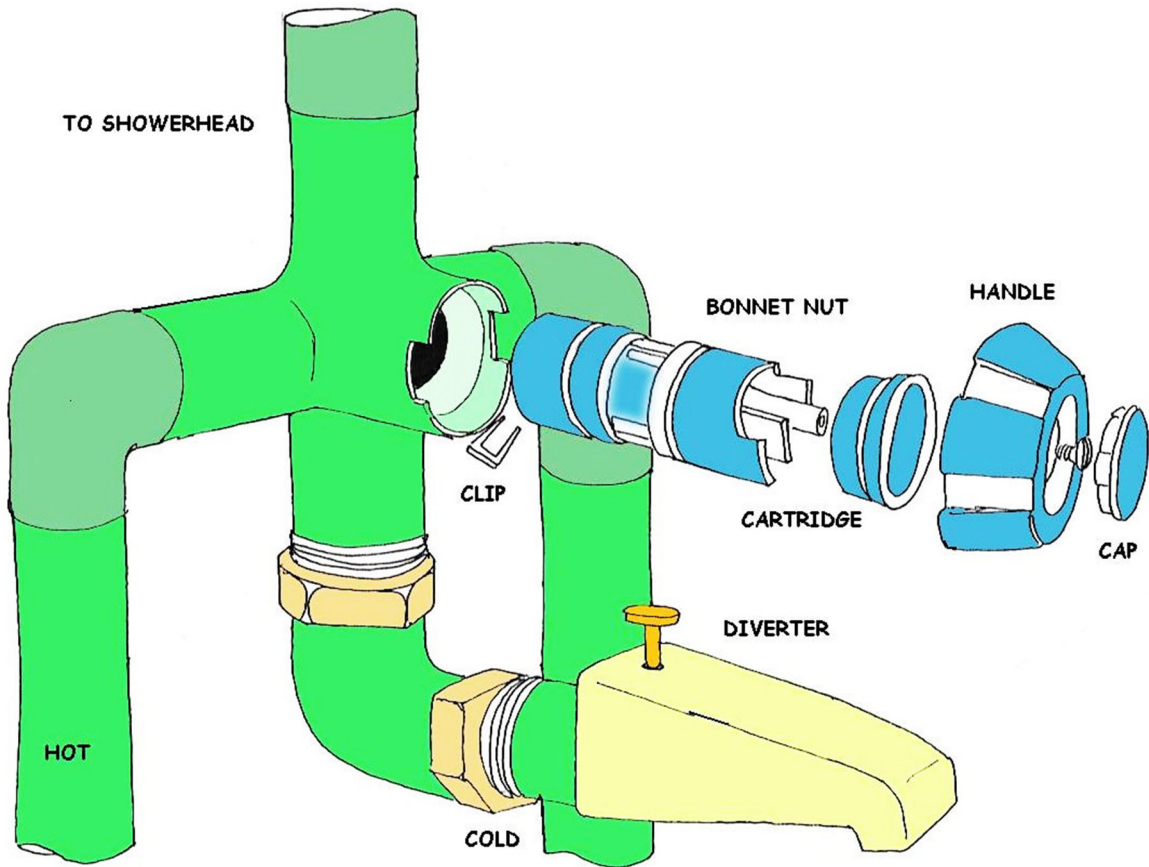



## Repairing Double-Handled Faucets

If a faucet is leaking, a washer (for compression) or O-ring (for cartridge) probably needs to be replaced.

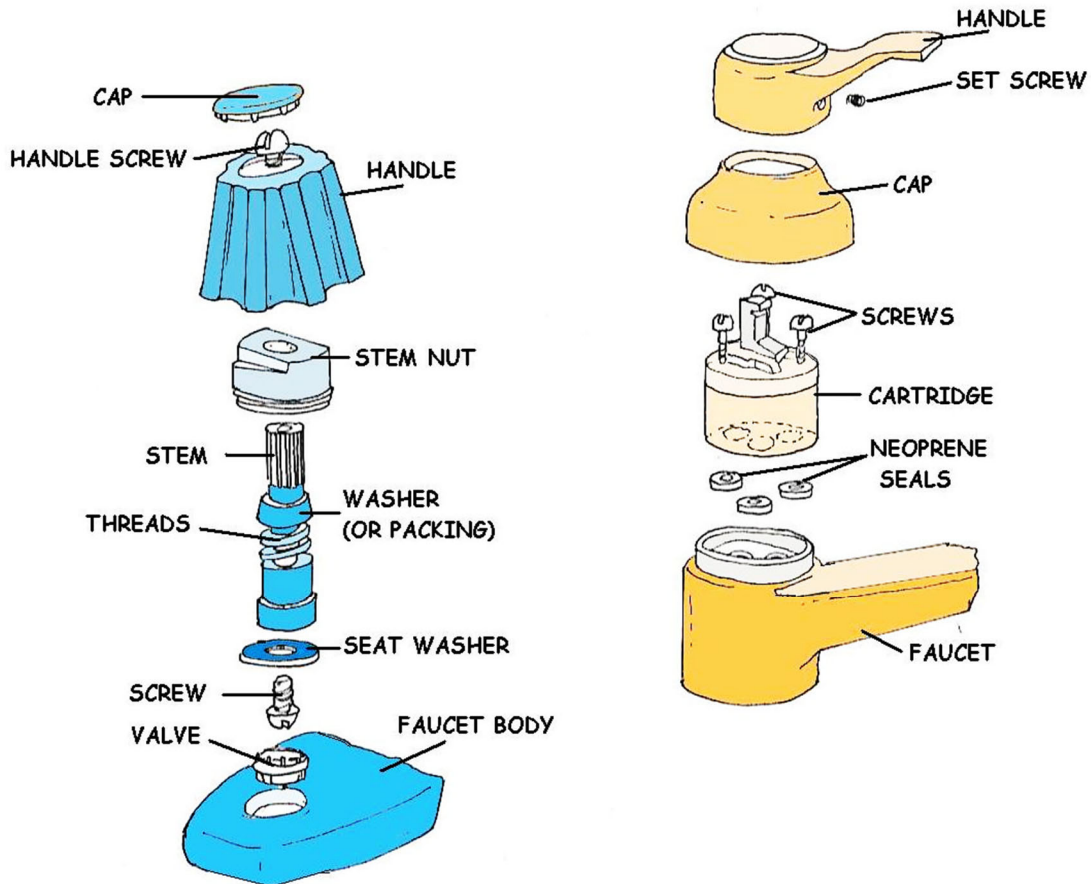

## COMPRESSION – WASHERLESS FAUCET EXAMPLES

Pry off the handle's decorative cap to access the knob screw. Unscrew and remove the knob to expose the stem. Make sure the water is turned off. For a compression handle, loosen the "packing" nut holding the stem. Remove the stem, flip it over and check the condition of the washer and O-ring. Replace the washer and O-ring if they show any wear or fraying.

A cartridge handle is repaired about the same way. Lift out the cartridge, check the O-rings and replace them as needed. As a last resort, replace the cartridge if the leak persists. Re-install the assembly, turn on the water and check for drips. If a compression faucet still leaks, the seat where the valve seals may need to be cleaned, or re-cut with a seat cutter tool.

To stop a leak around the handle, add a packing washer over the stem. If an old compression type handle still leaks, remove the packing nut and wind packing (a string gauze) around the nut to seal the assembly.

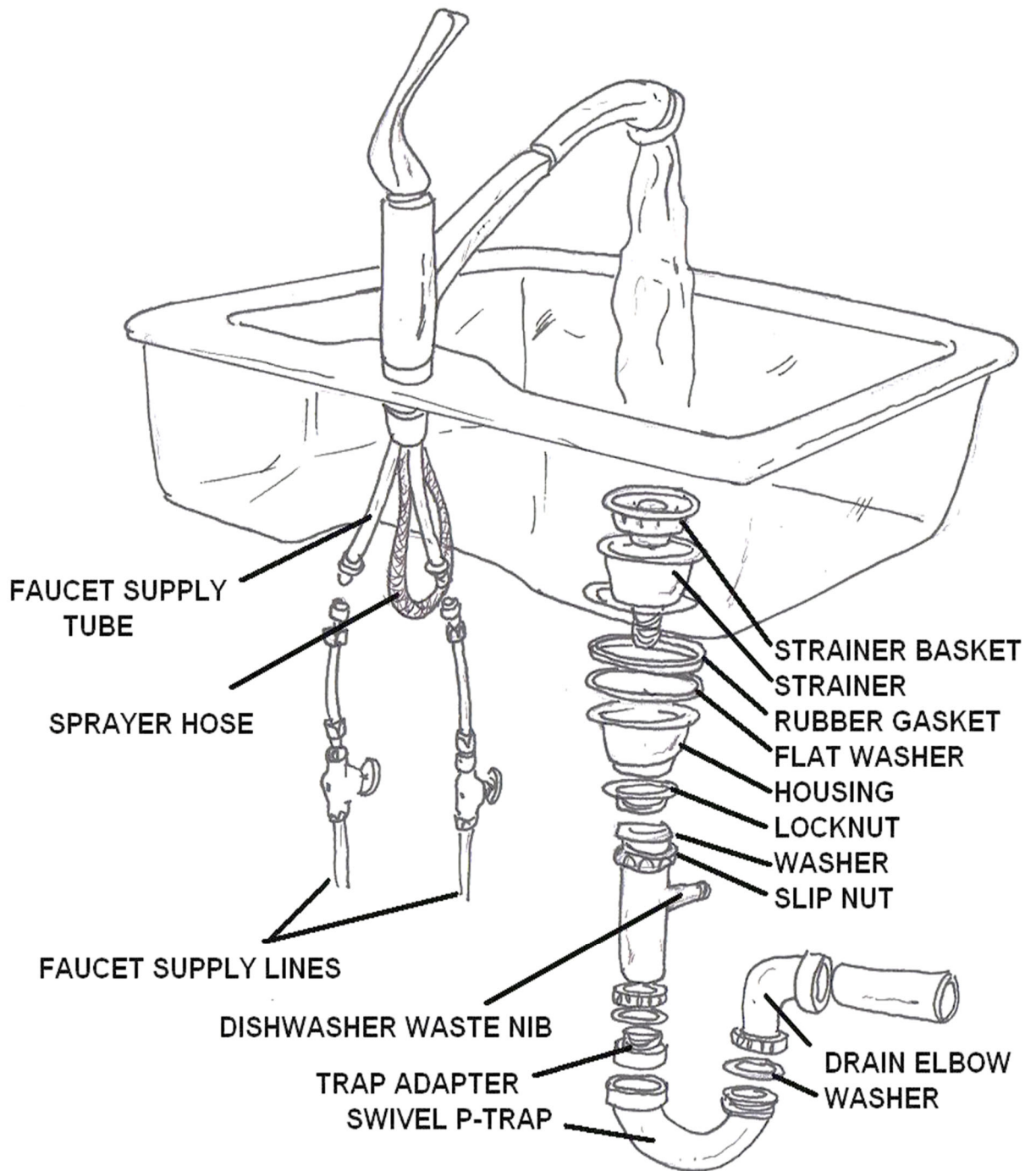

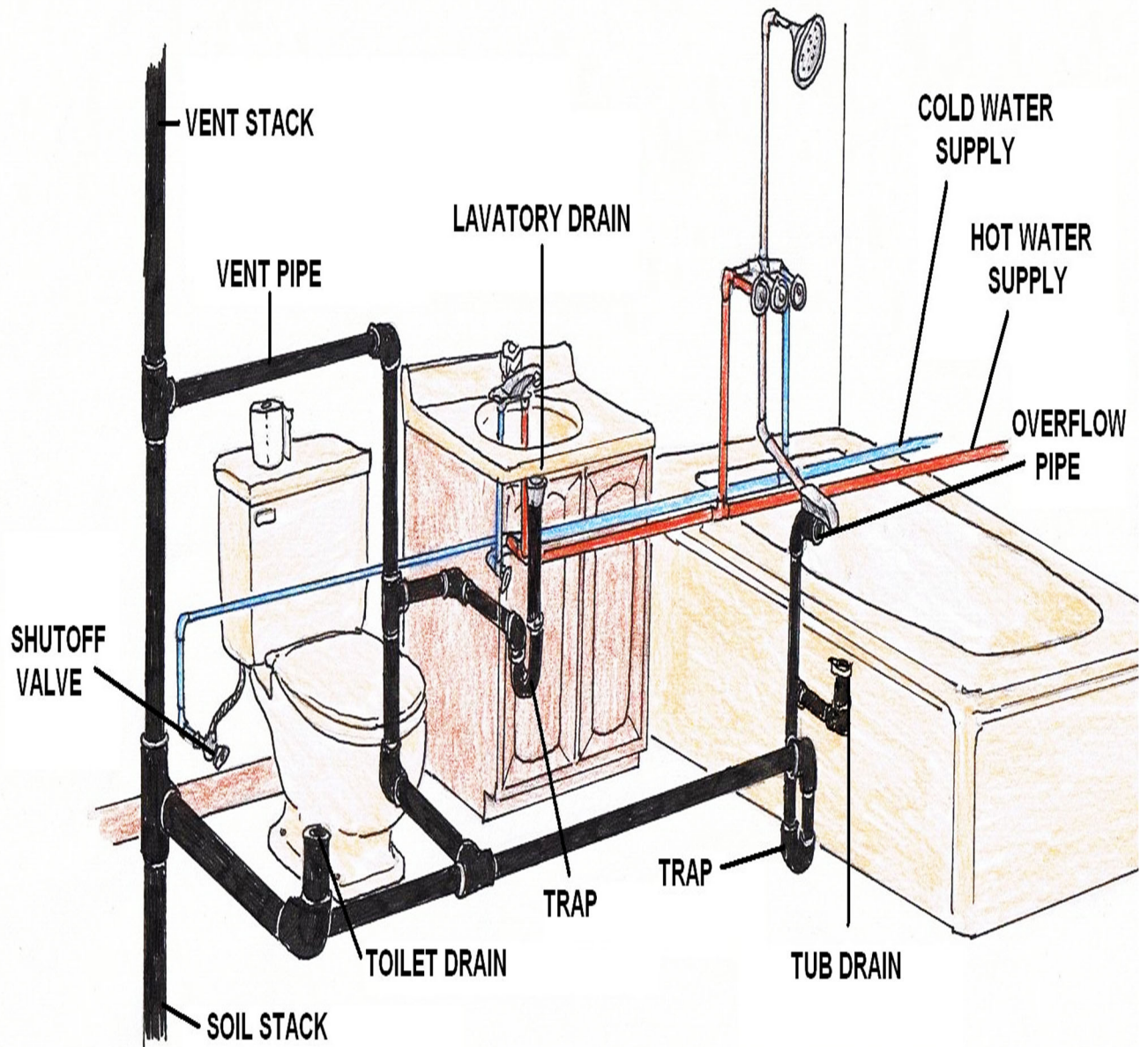

**BASIC BATHROOM PLUMBING DIAGRAM**

### **Fixing Ball-Type Faucets**

A ball faucet can leak in several places: around the handle, spout, collar, or base. We'll describe how to repair the whole works. Yet, fixing your faucet may only involve one of these steps.



Locate the leak and shut off the water. Remove the set screw holding the handle. Using the kit's wrench, snug down the adjusting ring if it's loose and slowly turn the water back on to see if the leak has stopped.

If the ring is already tight or the leak persists, turn off the water and remove the adjusting ring.

Take off the plastic or ceramic cam piece and its seal that sets on the ball valve. Replace the seal if needed. Make a note of how the ball valve slot lines up with its small alignment pin then remove the ball.

Most models have two rubber seals and springs that set under the ball. Remove them, clean out any deposits and replace with new seals and springs.

On the outside of the housing, cut off the rubber O-rings and roll on new ones and re-install the faucet.

### **Repairing A Single-Handle Cartridge Faucet**

After locating the leak and shutting off the water, pry off the faucet's top cap, remove the screw and lift off the handle piece.

Remove the lock nut and retaining clip holding the cartridge in place. Lift out the cartridge and inspect its seals. In most cases, the cartridge piece doesn't need replacing, but any worn or frayed seals should be replaced.

While the cartridge is out, inspect and replace the O-rings on the outside of the housing. Just cut them off and roll on new ones.

Re-insert the cartridge, align it as removed, and pop on the retaining clip. Fit the faucet back on and tighten down the lock nut. Re-position the handle, screw it down and put the cap back on.

### **General Care of Kitchen Sinks**

Today, kitchen sink bowls come in many different materials. Although enameled cast iron remains an attractive and durable product, many people today are choosing bowls made of stainless steel, and other solid surface materials for their added durability and stain resistance.

Bowls are available in Corian, Moenstone, Swanstone, Surrell, and others. The important thing to remember is to follow the manufacturer's instructions pertaining to the material of which your bowl is constructed. With some of the solid surface materials, scratches can be removed when lightly sanded because the color goes throughout the thickness of the material.

To prolong the life and appearance of enameled cast iron sinks, clean the bowl immediately after use. Use a non-abrasive cleaner. Constant use of abrasive cleaners can eventually wear the finish down, making it much more porous and susceptible to stains. This can also happen with enameled, cast iron tubs over a long period.

Don't allow fruit or vegetable juices or cleaning acids to stand on surface. An acid-resisting sink will safely resist lemon, orange, and other citrus fruit juices, tomato juice, mayonnaise, and other vinegar preparations if these are not permitted to remain more than a few hours. A regular enamel finish is not impervious to acids.

Teas and coffee grounds will also stain enameled surfaces, if allowed to remain very long.

Photographic solutions are even more harmful to enamel, and the amateur photographer should not be allowed to use the sink, because a fixture once damaged in this way can never be corrected. When cleaning the sink, use hot water and soap. Water and soap are not as hard on the enameled finish as strong cleaning solutions like washing soda or a gritty abrasive. If a cleaner is used, it should be one that specifically states that it is non-abrasive.

### **Lavatories**

The same precautions mentioned above for kitchen sink care pertain to lavatory bowls. Clean them often with hot water and soap. If a cleaner or cleanser is necessary, use one that is non-abrasive. Today, it is easy to eliminate the use of glass bottles and jars from the bathroom. This prevents the possibility of chipping the lavatory bowl if dropped. If acids or medicine spill on the surface, wash the spills immediately.

### **Bathtubs**

Modern bathtubs and showers can be made from a myriad of materials ranging from the conventional enameled, cast iron and steel, to fiberglass, acrylic, and man-made materials such as cultured marble. Many one piece tub or tub and shower combination units are made from gel coated fiberglass or acrylic plastic.

Never use abrasives on any of these materials. They can cause scratches to the surface. Usually they will clean with hot water and soap.

If that is not sufficient, a cleaning product recommended by the manufacturer of the fixture, or your plumber, can be used to handle heavier cleaning tasks.

## Fiberglass and Acrylic

With fiberglass and acrylic units, special polishes with no abrasives are available to protect their finishes by sealing the pores in the material, which makes subsequent cleaning easier. When decorating the bathroom or repairing something near the bathtub, place a heavy cloth over every inch of the bathtub surface so paint, falling tools, etc., will not mar or chip the enameled surface. Do not stand in the bathtub with shoes, as the nails and grit in the soles will scratch the enameled surface. Fiberglass and acrylic hubs should be cleaned with non-abrasive cleansers recommended by manufacturers.

## Water Heaters

You can't get along without hot water. Therefore, take care of the source--the water heater. If you have a gas or electric water heater, keep the temperature dial setting at or below the suggested Factory Energy Savings Settings listed on the water heater. Above that mark means excessive wear on the water heater and the potential for scalding.

The burner of a gas-fired water heater is easily accessible and should be checked by your plumber periodically to keep it clear of dust or sediment. The flame at full fire should be a light to dark blue. If the flame is more orange or yellow, the gas pressure or air flow needs to be adjusted. You can keep your water bills low by tempering all hot water as it is used. Letting the hot water faucet run on and on wastes not only water but fuel as well. With all water heaters, plan your hot water needs and you'll be delighted with the savings you get



All domestic water heaters are required to be equipped with a relief valve as a safety feature to prevent damage from excessive pressure and temperature. There is always danger that this valve may become frozen or corroded from long disuse. For this reason, it is advisable to trip the lever of this valve manually every two or three months to be sure it will operate freely if an emergency arises. **Note:** The discharge will be hot water that will need to be contained in a pan or bucket or allowed to drain to a floor drain.

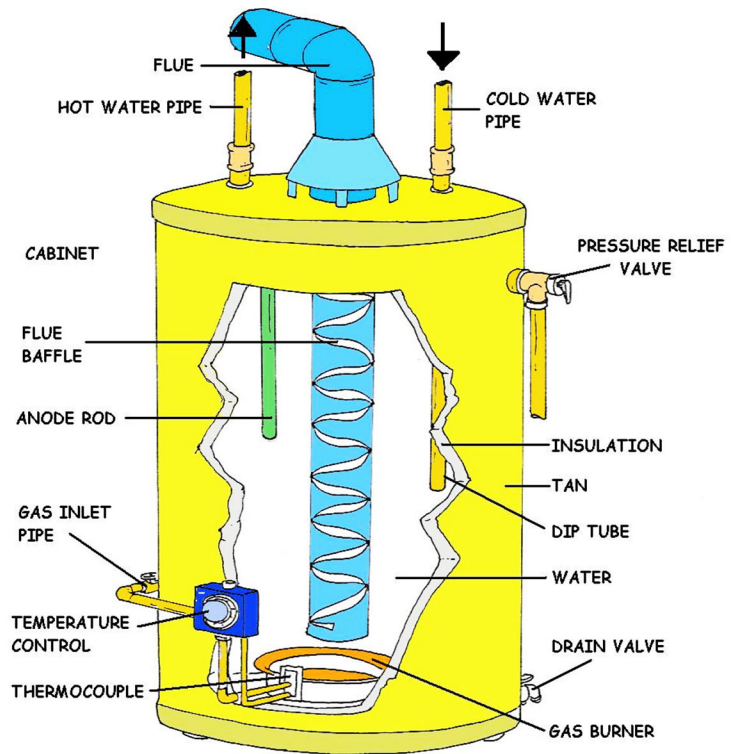

**GAS WATER HEATER**

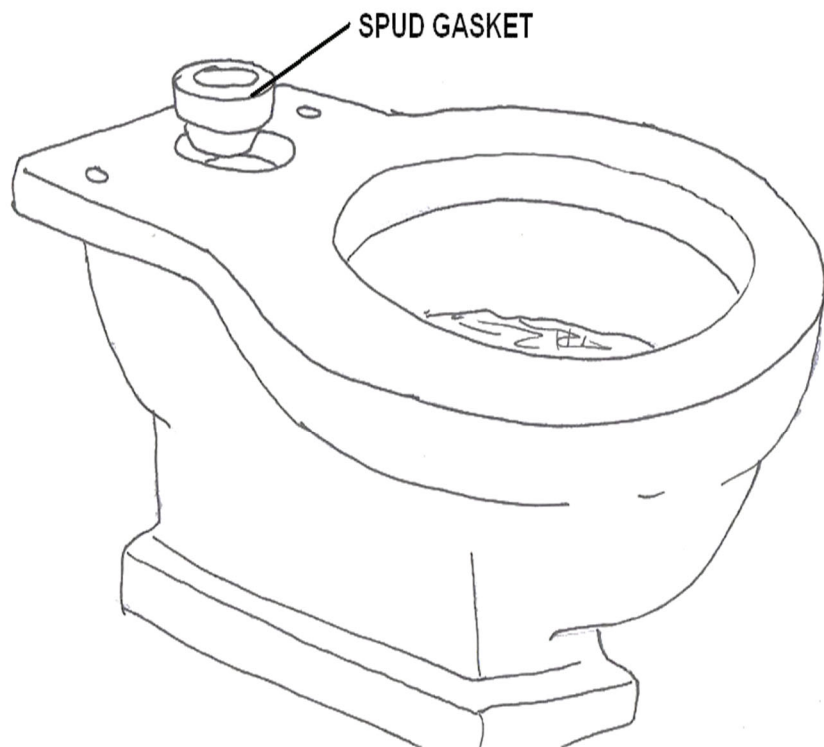
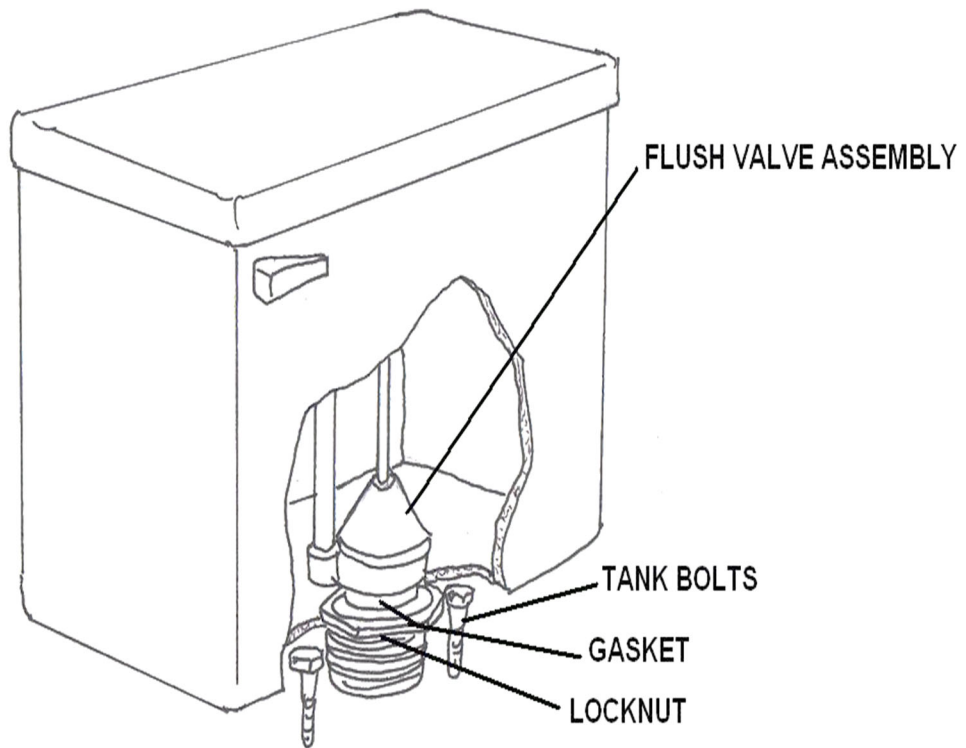

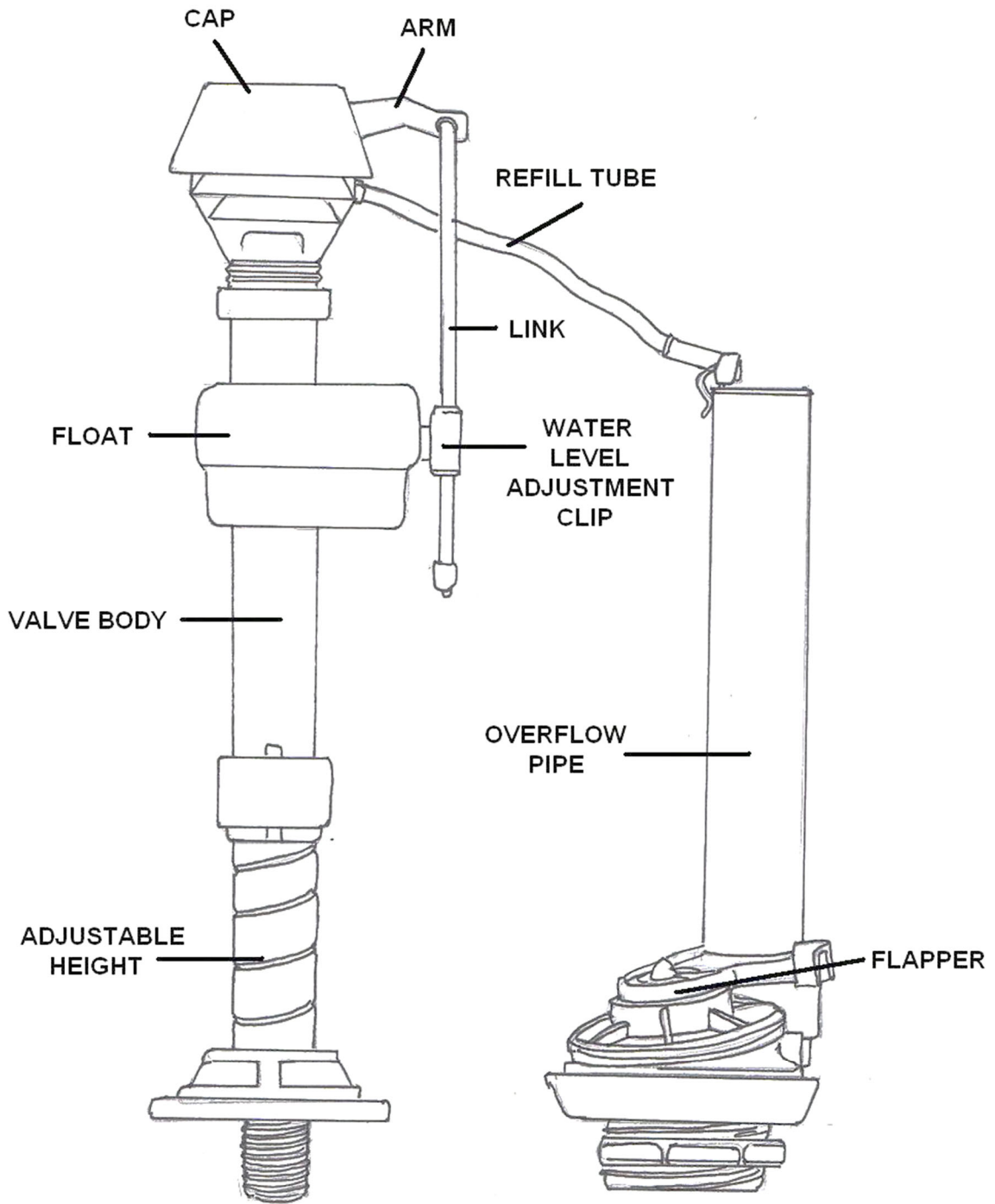

## TOILET FLUSHING ASSEMBLY



## **Water Closets (Toilets)**

Closet tanks and bowls are made of vitreous china and are impervious to ordinary household acids. If something more than hot water and soap is needed to clean them, apply a non-abrasive powder or cleaner recommended by your plumber. Many good bowl cleaners are on the market today.

Most plumbers however, have found that the "blue water" continuous bowl cleaners tend to accelerate the deterioration of the rubber and neoprene parts in the tank, due to the chemicals they contain.

Seat bumpers should be replaced if worn. Defective bumpers may cause breakage of the seat or hinges.

### **Stains**

Stains or moisture at the base of the closet bowl indicate that the joint or seal between the closet and its outlet have failed and should be reset immediately to prevent rotting of the floor, damage to the plaster of the ceiling below, and possible leakage of sewer gas into the home.

### **Types of Toilets**

#### **Water Closet Tanks**

If water continues to run into the closet bowl after the toilet is flushed, it is obvious that some part of the mechanism is out of order.

When the tank has refilled, if water continues to seep into the bowl or if there is a low humming noise, this indicates leakage from the tank. This leakage can occur from either the supply valve or the improper seating of the rubber tank ball or (flapper) on the discharge opening.

A small amount of food coloring added to the tank water will help you determine whether the tank ball in the bottom of the tank is leaking. Add it to the water after the tank is filled. Watch for the coloring to seep into the toilet bowl, and if it does, the ball or flapper over the discharge opening is not water tight. If the rubber tank ball does not fit tightly over the discharge opening, a defective ball, irregular seat or bent lift wires may be responsible. If the ball is worn out, miss-shapen or has lost its elasticity and fails to drop tightly into the hollowed seat, it should be replaced with a new one. Sometimes the ball is covered with a slimy coating which can easily be wiped off.

To replace the ball, shut off the water supply (a stop is installed underneath the tank where the water may be conveniently shut off at this point) and empty the tank or place a stick under the ball float lever-arm to hold it up, thereby shutting off the intake cock and preventing the tank from refilling. Then unscrew the ball from the lower lift wire and attach a new ball of the same diameter as the old one. (Note: some old tank balls swell from age and absorption of water.)

If the collar or seat of the discharge opening is corroded or grit-covered, it should be scraped and sand-papered until it is smooth and forms a uniform bearing for the stopper.

Straighten or replace bent lift wires so that the ball drops squarely into the hollowed seat.

A leaky, waterlogged float ball holds the supply valve open and does not completely shut off the water. If the rod which connects the tank float to the supply valve has become bent, it may prevent the float from reaching its full height, thus leaving the valve open and allowing leakage. This rod should be straightened and a little oil applied to the lever joints to insure smooth action.

Sometimes the tank will not fill sufficiently or will fill to overflowing. These difficulties may be corrected without disturbing the supply valve by bending the rod attached to the tank float upward or downward. If the rod is bent upward, the water will rise higher in the tank, and if downward, the water level will be lowered.

An overflow tube or pipe is provided in the closet tank to take care of the water in case it should rise above its accustomed level which should be at least 3/4 of an inch below the top of the overflow. While there is not much danger of its becoming stopped up, it might be well to examine it occasionally to see that it is in working order.

If water rises to the top of the overflow pipe an adjustment or new fill-valve assembly is necessary.



Testing 1.6 gallon toilets against each other.  
Toilet retrofit programs have save thousands of gallons of water.

## How a Toilet Works

The toilet is essentially a **"trap"** just like the one under the kitchen sink but only larger (for obvious reasons). And like a trap, the fact that water is always present in the bottom (the bowl) it **"traps"** or prevents sewer gases from backing up into the house.



Below are a couple of the principles involved in how a toilet works:

- Water seeks its own level.
- A simple siphon
- Flush or Flood
- Momentum

Simply speaking, we **"flood"** a toilet to make it work.





When we press the handle on the tank (not shown here), the flapper valve is opened and the water stored in the tank is released into the bowl at a very fast rate causing the water level in the bowl to rise and overflow rapidly. The rising water seeks its own level and overflows down the trap creating a siphon that literally sucks the water out of the bowl.

The siphoning continues until the water level in the bowl falls below the lip at the bottom of the bowl.

When this happens air enters the drain path and **"breaks"** the siphon and the flush stops. But since the siphon created such momentum in the moving water the new level in the bowl is considerably lower than before the flush.



This is where the standpipe comes in. With the flapper valve closed, the tank starts to fill again and a separate tube directs water down into the standpipe directly into the bowl through a bypass under the flapper valve. This filling of the bowl will stop automatically when the tank is filled.

If for some reason the tank float valve (*not shown here*) fails to shut off the water filling the tank, the water will continue to rise until it reaches the top of the standpipe which will drain the overflow from the tank into the bowl of the toilet.

Under these circumstances though, the toilet will not flush because the volume of water being discharged into it is minimal. It merely overflows in a trickle down the back end of the (trap) of the toilet.

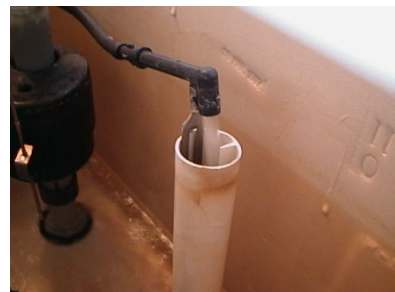



These are European style toilets. Notice the device that keeps the lid up for men and the gravity water tank. Below is also a common toilet in other parts of the world. It is a floor mounted device that flushes and is still being made and installed. It is difficult for Americans to figure out how to use it properly. It is best to squat and not sit or lay on the toilet. Believe it or not, most countries that utilize these holes in the ground also charge about 50 cents to use it and may not provide toilet paper.





Three Compartment Grease Interceptor



Common and worn out kitchen Grease Trap. The grease contains lots of acid and this acid will eat metal as with this grease trap.

# Collection System Diagrams

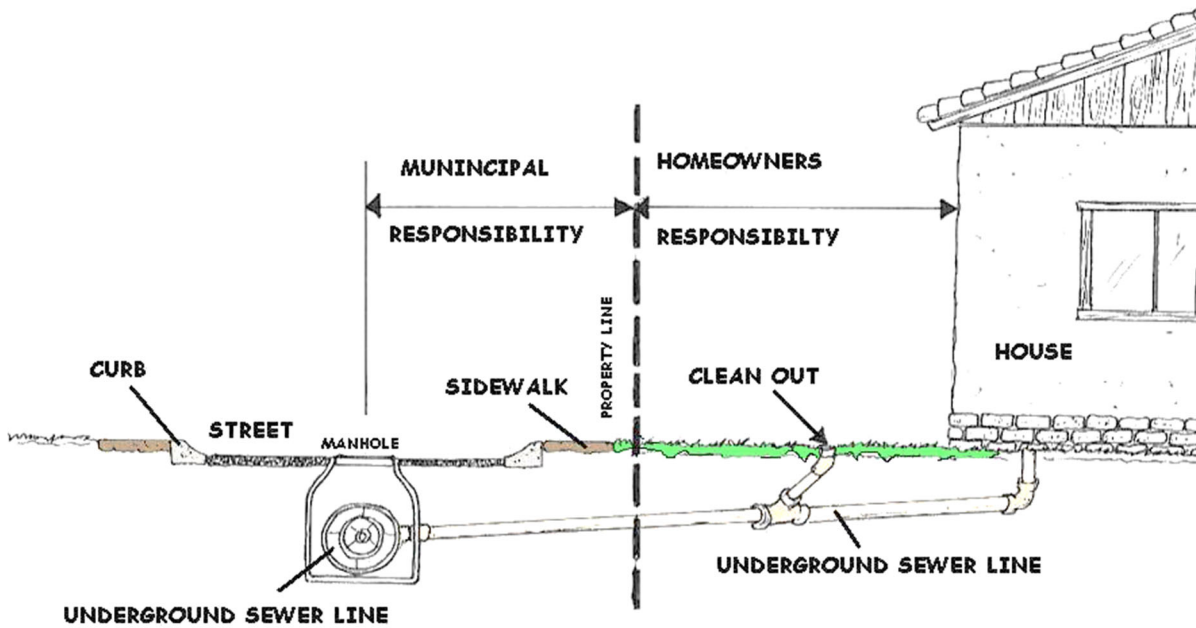
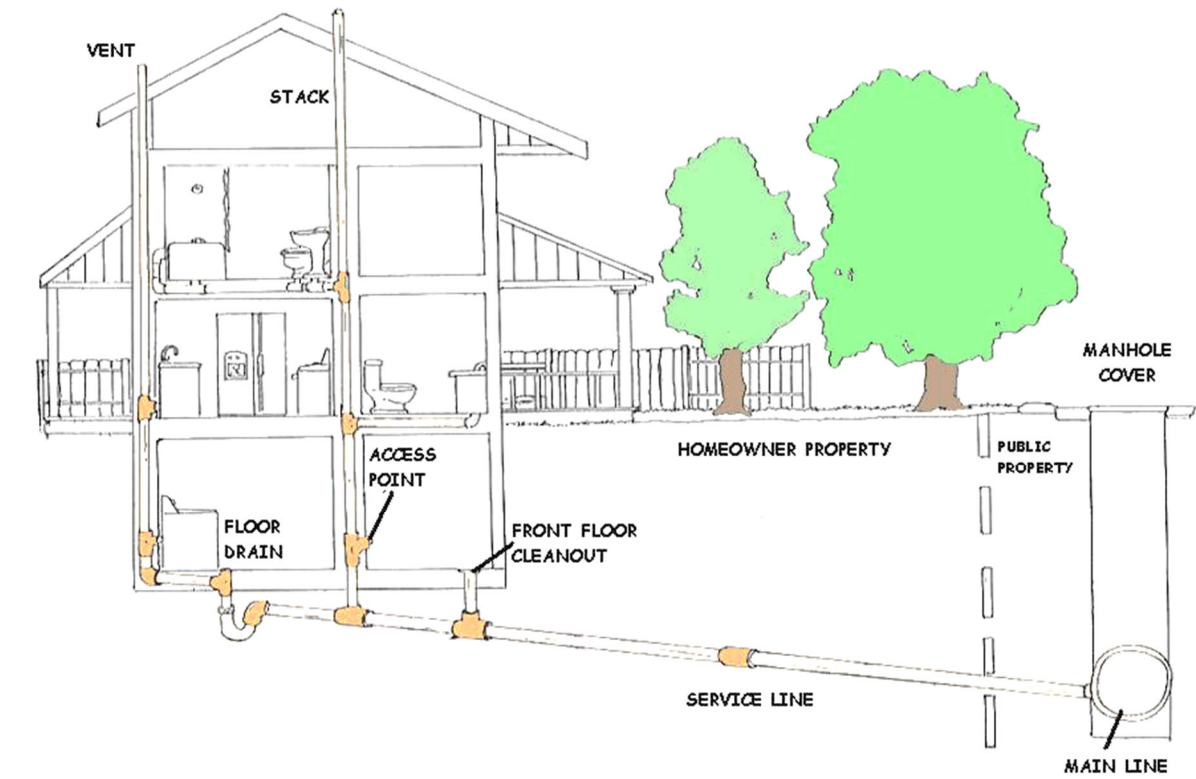

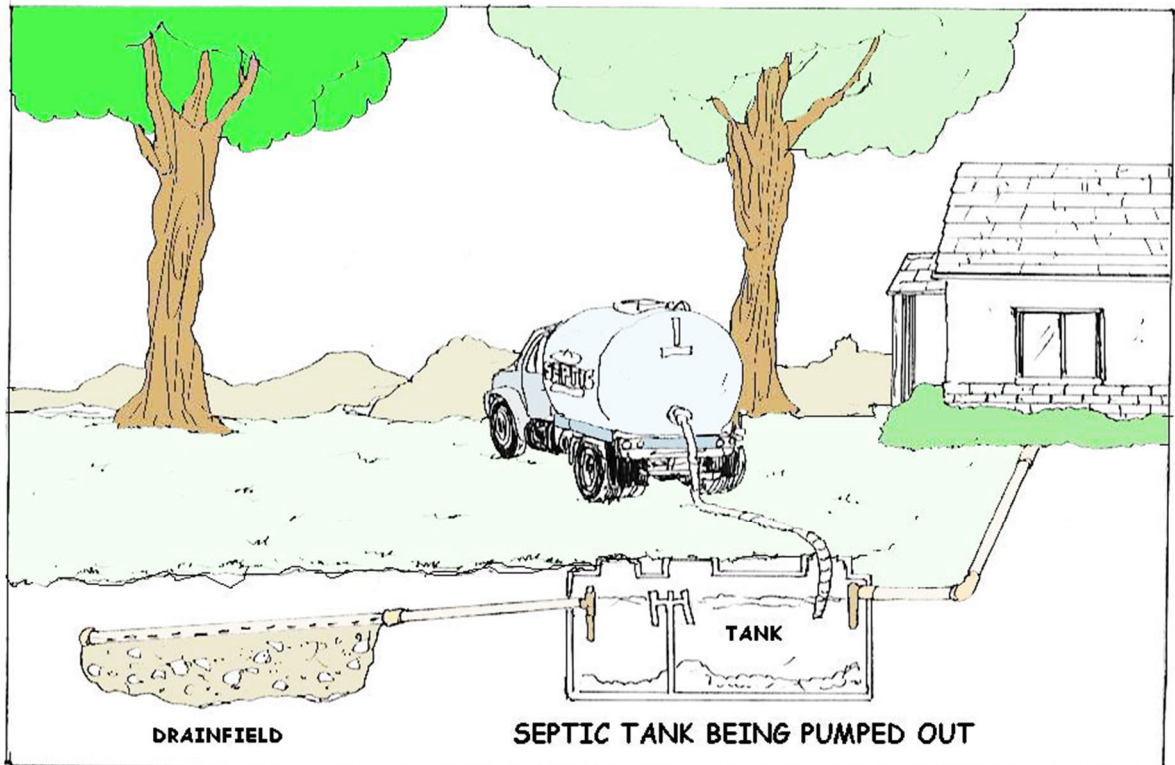
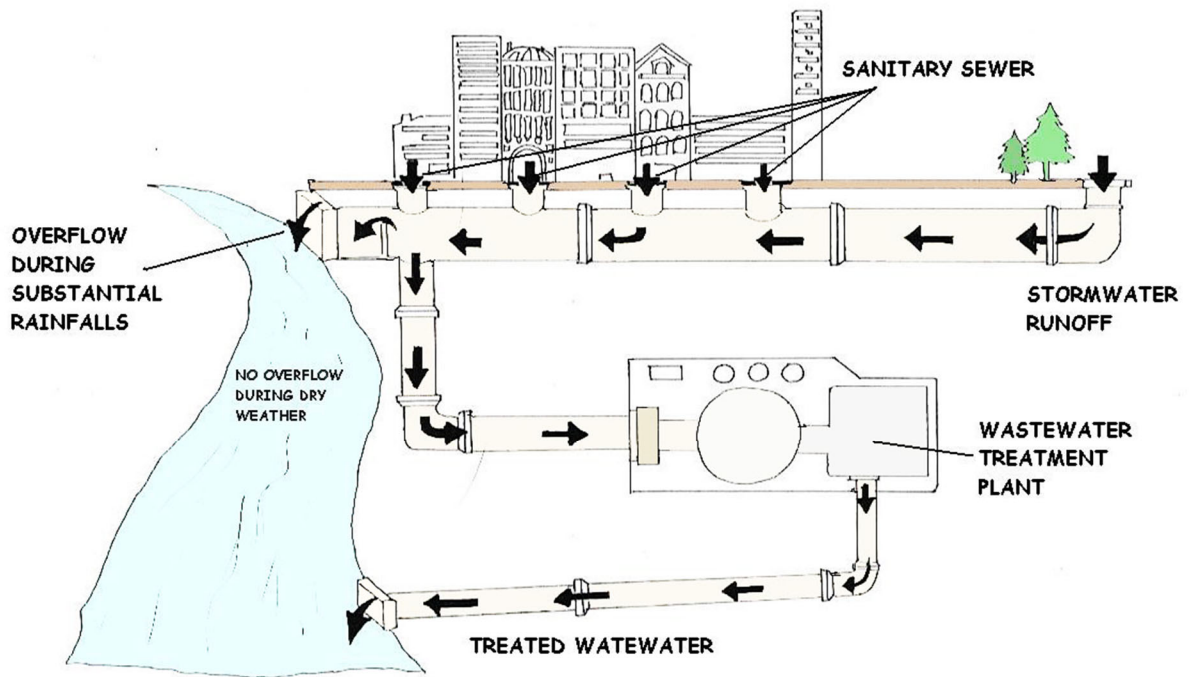



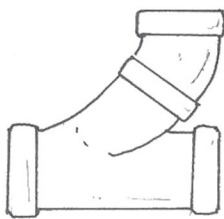
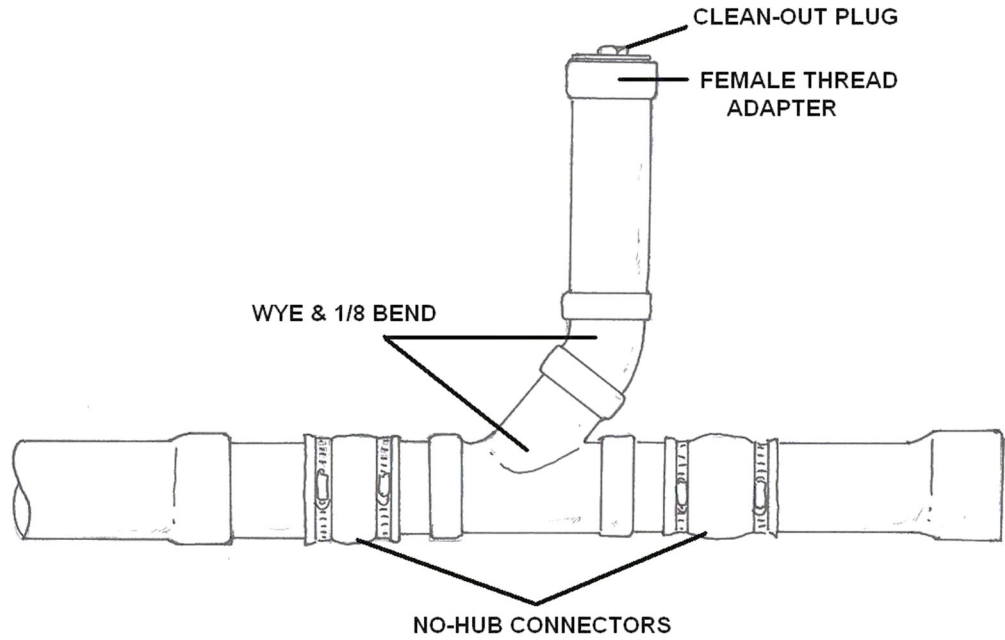

WYE & 1/8 BEND

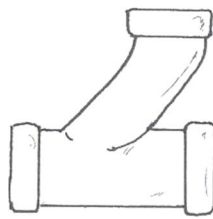

COMBO

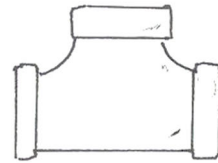

REDDING TEE

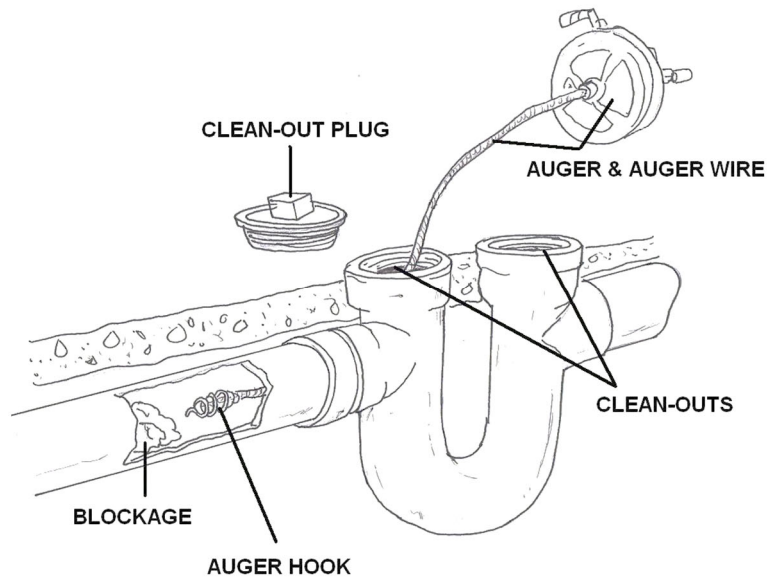

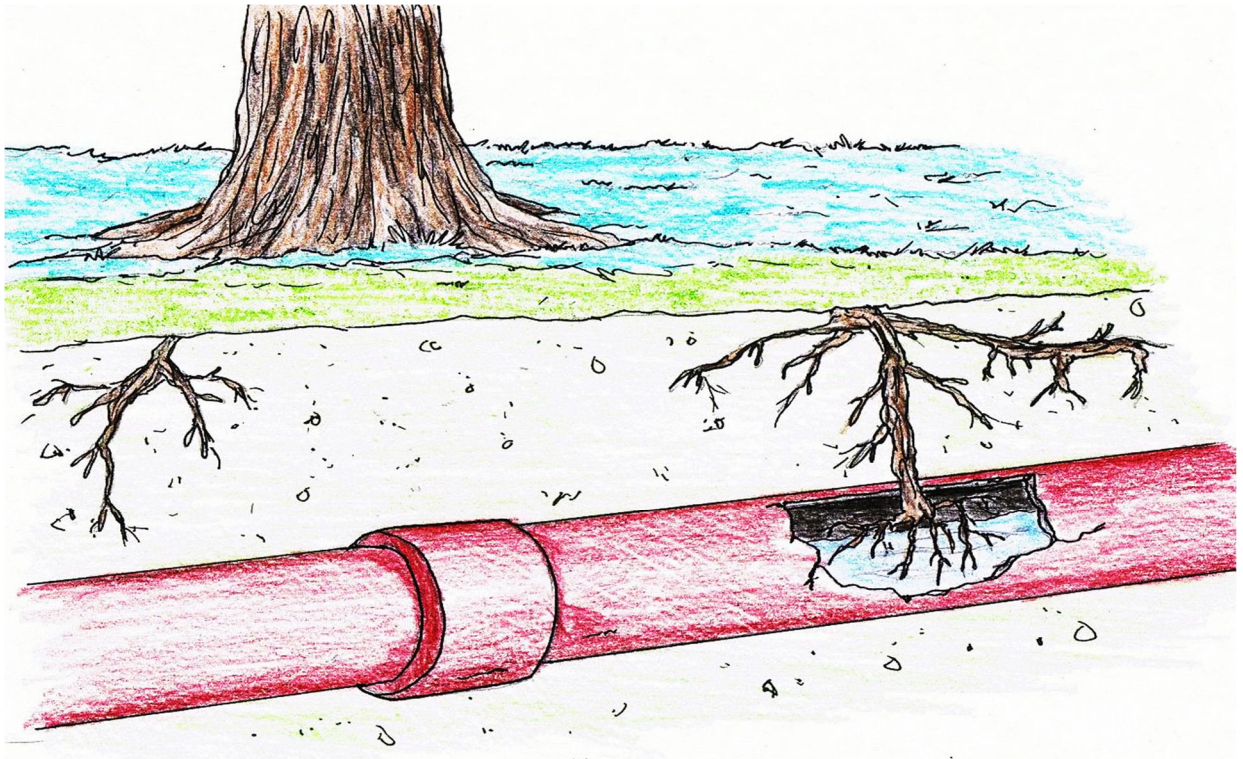

**ROOT INFLIRATION DIAGRAM**

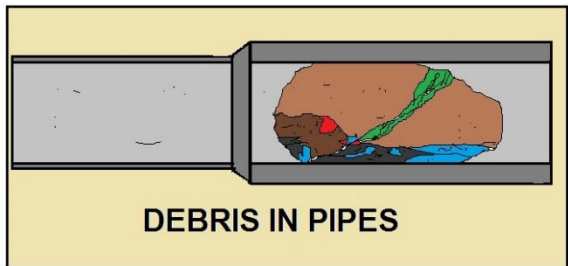

**DEBRIS IN PIPES**

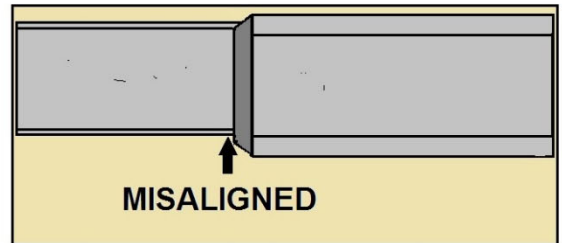

**MISALIGNED**

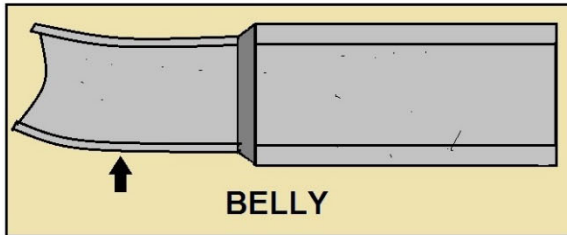

**BELLY**

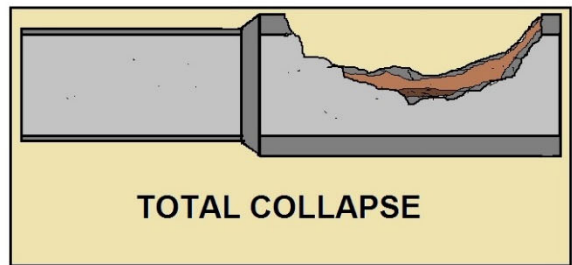

**TOTAL COLLAPSE**

**DAMAGED SEWER PIPE EXAMPLES**

# Press Release

## Town Installs Waterless Urinals

We haven't had much rain lately and need to think of ways to conserve water. Because of the current drought and social responsibility of saving our natural resources, the Town of Sunflower's Water Department is excited to announce the Waterless Urinal Retro-fit Pilot Program has begun. The Water Department has implemented this along with several other new water conservation methods and technologies to help reduce our daily water demand.

The Town has installed 17 of these completely waterless urinals in public facilities throughout the Town. These urinals are expected to save 750,000 gallons per year. This type of urinal replacement program is successful in 30 cities throughout Arizona.

Waterless urinals work completely without water. Waterless urinals can be easily installed to all restroom applications. This fixture saves up to 45,000 gallons of water and more per year per fixture. It greatly reduces typical urinal maintenance and improves restroom sanitation.

### Waterless urinals eliminate and/or minimize these common problems:

Urinal Odors	Vandalism
Flush Valve Repairs	Line Encrustations
Low Water Pressure	Leaking Flush Valves
Costly Flush Sensors	Water & Sewer Costs
Stoppages and Overflows	Rest Room Shut Downs
High Demand on Septic Tanks	Mitigation for Water Usage

The Water Department will closely analyze and test these and other water conservation devices and hopefully install more devices throughout public facilities. Water saving devices, along with water conservation awareness are major components of the Town's Water Conservation Program.



### HOW THEY WORK:

No-Flush urinals resemble conventional fixtures, and easily replace them. They install to the regular waste lines, but eliminate the flush water supply lines. Flush valves are eliminated as well; there are no handles to touch, no sensors, and no moving parts! The urinal bowl surfaces are urine repellent; urine is 99% liquid and its drainage is affected without flush water. Daily cleaning procedures are the same as for flushed urinals.

Bill Fields, Water Resource Specialist, "**After a balanced consideration the Waterless urinal seems to be a water conservation fixture whose time has come. It clearly reduces maintenance costs, and may do so dramatically and immediately for some installations.**"

The best part is an automatic savings of 1 - 3 gallons of water per usage, depending on the model of flush urinal you're replacing." **"In any new construction, or whenever you plan to replace a flush urinal, Waterless urinals should be given serious consideration and possibly be required in the near future."**

You can come and see this new technology in action and get a "free" water saving kit at the Water Department.



Prepare for extensive wall damage when retrofitting to a waterless urinal. You may need to replace tiles and drywall. Notice the square box on the right hand side, this is a trap primer for the floor drain. The trap primer keep a small amount of water to keep the drain's trap wet to prevent sewer odors from coming up.



## Shower Equipment

Some Plumbing Codes require the use of pressure balanced bath/shower valves to prevent scalding in new homes and during remodeling.

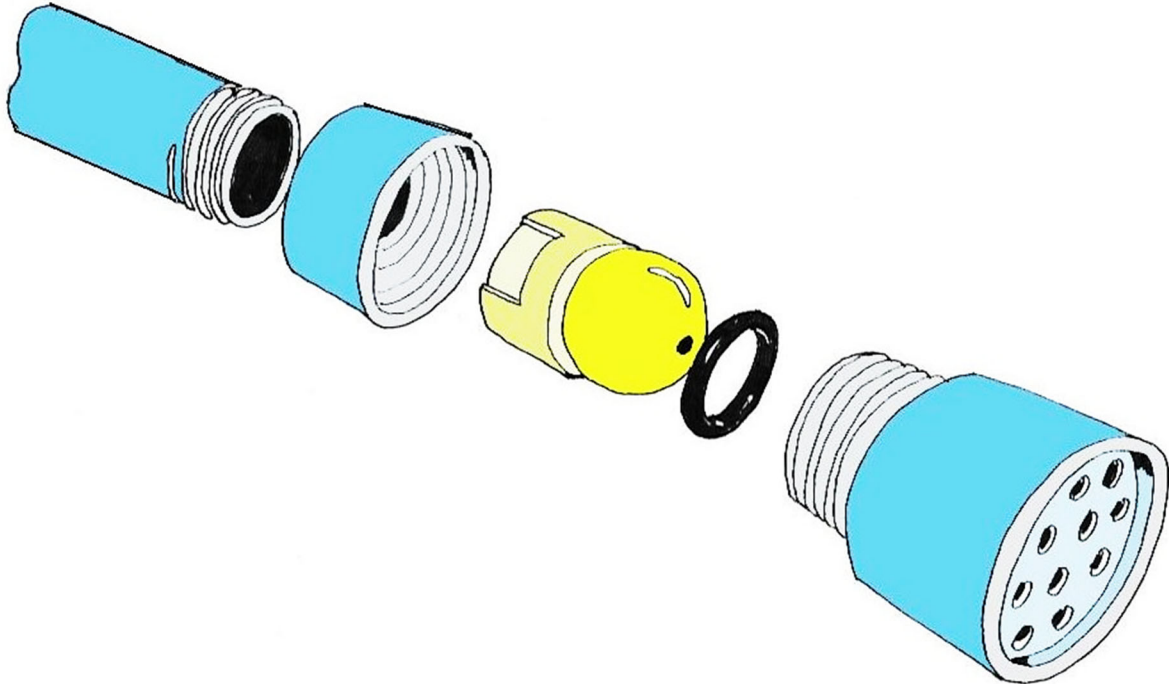

There is more potential for the scalding of a person showering if the pressure fluctuates. Most people aren't aware that young children and older persons can be scalded much sooner than adults. Lowering the water temperature at the water heater will minimize the potential danger at the tub spout or shower head and is the best preventive action which can be taken to prevent scalding. A small child doesn't have to soak in overly hot tap water to get scalded. Tragically, injury can happen literally in the blink of an eye. 150 degree water can scald in just 1/2 second, 140 degrees scalds in just 1 second, but it takes four minutes for water at 120 degrees to scald.

**POINT OF CAUTION** - - Never let a child bathe unattended, because of the danger of scalding and injury. In addition, always turn cold water on first, followed by the hot water until the desired temperature is achieved. That way, no one is exposed to straight hot water.

You need not rush to buy another shower head if the one you have suddenly gives off an uneven spray. It's probably clogged with mineral deposits which build up in the shower head and distort the shower stream. If the shower head holes are clogged, remove the face of the shower head, clean the back surface and free holes with a coarse needle. The latest shower heads on the market are all self-cleaning and need no such attention. The only positive preventive measure is investing in a water softener. When changing shower heads, wrap adhesive tape around the packing nut or pad the wrench jaws with a cloth so you won't mar the finish.

### **Chrome Plating**

Chrome plating is a hard and durable finish that requires little attention except for the occasional washing with soap and water.

Salt air or other corrosive atmospheres have a destructive effect on chrome. Where chromium-plated fittings are exposed to these agents, it is important to wash them frequently. After they are washed and dried, it is advisable to apply a protective coating such as ordinary furniture wax.

Green spots may appear on chromium plating. If this happens, prevent the rust from spreading by scouring the spots with the same kind of powder which manufacturers recommend for enameled, cast iron fixtures. When the spots have been removed, apply a finish of wax.

### **Thawing Frozen Pipes**

Frozen plumbing pipes, although inconvenient, do not constitute a calamity. The calamity may come if the pipes are thawed with a blow torch, and if the open flame or the torch is allowed to come too close to combustible material, such as insulation, wooden joists or flooring.

Another danger from the use of a torch arises when both ends of a pipe are clogged with ice and when the heat is applied in the center. The application of the heat of the torch at the center of the pipe is likely to cause the water to flash into steam, potentially causing an explosion with disastrous results for the user of the torch.

It is far better to adopt the slower and more conservative procedure of melting ice by the use of a blow dryer, or heat gun.

### **Preventing Frozen Pipes**

Before the cold freezing weather sets in, make sure that all the garden hoses outside your home are disconnected. Failing to do so can cause not only the hose but also the hose bib to which it is connected, to freeze and be damaged.

This is especially important with anti-freeze hydrants. The hose must be disconnected to make the faucet freeze-proof. Failure to do so will trap water in the faucet body, which then can freeze. If the hose is disconnected, the anti-freeze faucet can properly drain, and this will prevent freezing.

Water pipes which are exposed to freezing temperatures or drafts should be covered with insulation. Whenever possible it is best to drain systems not being used in severely cold weather. Small water pipes will freeze quicker than will waste or sewer pipes.

Never leave a garage door open in severely cold weather if there is plumbing in the garage. The cold and draft can freeze water lines in minutes. Pipes located in unheated basements or garages should be insulated with a commercial covering. When pipes are laid underground they should be below the frost line to prevent freezing.

## Noises in the Plumbing System

In designing the plumbing system for a new house, a plumbing contractor will endeavor to make it as noiseless as possible. Manufacturers of plumbing fixings are making every effort to reduce the noise connected with the operation of their equipment, and contractors have been very successful in eliminating much of the noise formerly associated with plumbing systems.

Because so much of the noise is due to water traveling at a high velocity, it follows that whatever can be done to reduce the velocity of the water will correspondingly reduce the noise in the system. It is for this reason that it is so important not to skimp on the size of the water supply piping. Larger pipe will not only provide a more adequate supply of water but will reduce noise.

There are three general types of noises found in some of the older plumbing systems. These are water hammer, whistling and chattering.

### **Water Hammer**

Water hammer is the thump in the piping heard when faucets or valves are turned off abruptly.

There is no excuse for water hammer. It can usually be eliminated by the installation of an air chamber or short length of pipe in the wall where each supply pipe enters a plumbing fixture.

In some cases, however, the ordinary type of air chamber will not prevent water hammer. In such cases, special devices known as shock arrestors should be installed on the main line near the meter or as close as possible to the cause of the noise.

Sometimes water hammer is due not to the plumbing in the house in which it is heard but to a condition outside of the house, either along the water main or in a neighboring house. In such cases, skillful detective work by an experienced master plumber is necessary to ferret out the source of the trouble and to plan corrective methods.

**Water hammer** should not be permitted to go on indefinitely. The noise is only an audible symptom of what is going on in the piping. The piping is being subjected to the wear and tear of a multitude of shock waves. The result will be leaks in piping, tanks or fixtures unless the condition is corrected.

**Chattering** in the piping may be caused by loose pipes, by pipes rubbing against a metal projection, by worn faucet washers or looseness of other inside parts.

**Whistling** is caused by the speed of water flowing through piping which is usually too small. A pressure reducing valve will help as will a general straightening out of the plumbing system.

Whistling is most common at bends and tees in the pipe.

## Draining Plumbing in a Vacant House

If your house is to be vacated during cold weather and the heating system turned off, follow this procedure:

Shut off the water supply at the main shut-off valve at the street. Then beginning with those on the top floor, open all faucets and leave them open. When water stops running from these faucets, open the cap on the main shut off valve in the basement and drain the remaining water into a pail or tub. Remember that this cap must be closed after the faucets have run dry or the house water supply will flow from this valve and flood the basement.

Remove all water in the traps under sinks, water closets, bathtubs, and lavatories by opening the clean out plugs at the bottom of traps and draining them into a pail. If no plugs are provided, use a force pump or other method to siphon the water out. Sponge all the water out of the water closet bowl. Clean out all water in the flush tank.

Fill all traps with a non-freezing solution such as mineral oil, windshield washing fluid or RV type anti-freeze.

Drain all hot water tanks. Most water tanks are equipped with a vented tube at the top which lets air in and allows the water to drain out the faucet at the bottom. Make sure all horizontal pipes drain properly.

Air pressure will get rid of trapped water in these pipes, but occasionally the piping may have to be disconnected and drained. To be safe, have your plumber check your entire plumbing system.

If your house is heated by hot water or steam, drain the heating pipes and boiler before leaving. Burners and pilots should be completely out and the main water supply turned off at the basement wall or street. Draw off the water from the boiler by opening the draw-off valve at the lowest point in the system.

Open the water supply valve to the boiler so no water will be trapped above it. If you have a hot water system, begin with the highest radiators and open the air valve on each as fast as the water lowers.

Every radiator valve must be opened on a one inch pipe system to release condensation.

**Note:** When you return home, refill all the systems **BEFORE** lighting the hot water heater or boilers.





## How Not to Install Plumbing Section



Upside down - sideways trap, works for a little while. NOT!



Top photograph, no trap needed when you have a long flex hose.  
Bottom, this is a new side trapper. NOT!





Top photograph, I am not sure how you mix the plumbing and the electrical system together, but this guy did it. Bottom, I guessed it worked.





Top photograph, never install electricity near a water outlet.  
Bottom, there's room here...let's put the u-trap here. NOT!



## **Drains & Vents - Chapter 7**

### **Odors in the Plumbing System**

The well-designed and correctly installed plumbing system is odorless. Odors are most likely to arise from leaks in the waste or vent piping or from traps which have lost their water seal. In an incorrectly installed system, there are, of course, many opportunities for odors to result from defects in the system, particularly if it is not properly vented.

Unusual odors should never be ignored. Such odors are often an indication that sewer gas is present. Sewer gas, while not always deadly, is noxious and capable of causing headaches and other minor illnesses. Sewer gas is foul smelling air and should be prevented from entering the house.

If it is suspected that sewer gas is entering through a leak in the piping, a plumber will subject the system to a test either by means of smoke, water or oil of peppermint. The test will indicate the location of the leak.

In order to explain how the sewer gas may enter a house through a plumbing fixture, it is necessary to clarify the function of traps and vents. Every plumbing fixture is the terminus of the city water supply system and the beginning of the city sewerage system. The faucets control the water supply. The traps and vents control the sewer air. They do so by a very simple method.

Sewer air will not penetrate a water barrier. Therefore, a device is employed which keeps several inches of water between the house air and the sewer air. This is the trap, which is plainly visible under such plumbing fixtures as sinks and lavatories. It is built into water closets. In the case of bathtubs and shower cabinets, it is usually concealed in the floor or basement.

A trap, however, would lose its water seal by siphonic action every time a fixture is used unless the air on the sewer side is balanced with the air on the house side. This is the function of the vents. Occasionally, due to changes in atmospheric conditions, a compactly vented trap will lose its seal.

Usually, however, when a trap loses its seal it is due either to incorrect design of the vents, absence of vents or to evaporation of the water in the trap. Traps under fixtures that are used infrequently should be filled with water from time to time to insure an adequate trap seal.

### **Drains**

Plumbers get more calls to open clogged drains than for any other service. Many such calls could be prevented by greater care in the use of drains. The most-used drain is the one in the kitchen sink and that is the drain most often clogged.

Preventing this situation can be done by carefully watching what is emptied into the sink drain and by the regular use of a safe biodegradable waste digester. Your plumber can give you more information on these products.

## Sink Stoppages

Sink stoppages are usually caused by liquid fats, emulsified by warm dishwater and carried through the pipes. The water cools as it proceeds to the main sewer and leaves the fatty deposits along the way. A film of grease forms on the pipe wall, then another and another. Coffee grounds and bits of food add to this accumulation layer until the pipe becomes impassible.

Pour excess grease into a tin can and throw it out with the garbage, not down the sink drain. When using a food disposer, always let sufficient cold water run to carry the particles down and into the main line to prevent buildup in the smaller waste lines.

In the event of a stoppage, you should have a "plumber's friend," or plunger - a large rubber suction cup with a wooden handle. Cup it tightly over the drain and plunge it vigorously several times. If it is a double drain sink, make sure you seal the other drain, so water will not splash out into the other bowl or on you. Drain piping can also be cleaned by removing the J-bend on the trap below the fixture. First place adhesive tape around the packing nut or wrap the wrench jaws with cloth to prevent scratching the metal surface. If plastic piping is in place, do not grip the nuts too tightly with the wrench, as they can crack easily.

Place a bucket directly under the pipe to catch any dripping from the open pipe. Pull out the clogging material with a piece of wire or small hand-turned cable. If you take the trap off, have some new gaskets ready to slip into the joints.

## Using A Sewer Snake

Another handy tool is a sewer "**snake**" or auger. It's basically a flexible metal rod with a spiral hook or ball on the end.



There are two basic snakes: 1) a closet auger with bent tip made to fit in a toilet's built in trap, 2) a drain auger which is a coiled rod or flattened metal strip.

With both augers, when the rod meets an obstruction in the line, tighten the handle and ram the snake into the clog -- sometimes that's all it takes to clear the line. Otherwise, crank the rod clockwise so the hook (or ball) snags the clog.

Back the snake off slightly, then steadily push inward again while turning the handle clockwise until the debris is solidly hooked.

Firmly push the snake back and forth until the obstruction is freed. The clog may have moved a bit further down the line just to get stuck again.

So, repeat the procedure while running water and feeding out more line -- all the way to the septic tank or city sewer line connection if possible.

Once the clog is gone, reconnect the sink's trap and flush the line with water. Check the connections for leaks. Run more water down the drain and monitor it a few minutes to ensure the clog is gone. If the blockage still remains (like tree roots), you may need to rent a commercial "power" auger with a rotor or blade bit that chops up whatever is in the line.

### **Toilets**

A clogged trap way in a water closet is a ticklish problem, so be careful with whatever method you use for cleaning the drain. Most water closets are made of vitreous china which might crack if exposed to extremely hot water.

A plunger will normally handle simple toilet clogs. Another method of cleaning a water closet trap or toilet is the use of an auger with an adjustable, crank-type handle. Known to plumbers as a "**snake**," the spring-steel coil is easily worked past the trap and down the pipe. A three foot auger is inexpensive and will quickly drill through most clogs. Use the auger carefully. Careless handling may crack the toilet.



### **Tubs**

When trying to clear a plugged bathtub drain, place a heavy cloth in the bottom of the bathtub so your shoe soles won't scratch the bath's enameled surface. Hold your hand or rag over the waste and overflow plate, cup the plunger over the drain and plunge it vigorously several times. If it doesn't open easily, the drain may require cabling to open it.

Heavy steel spring coils should not be used to clean traps under lavatories, sinks, or bathtubs. A more flexible type of wire or spring should be used -- one which is easy to work through the bend of the trap.

### **Floor Drains**

To clean out a floor drain, remove the strainer or grating which covers the drain box. The dirt and grease can then be dug out with a spoon or a stick. After that, a hooked wire or coil spring-steel auger will clean out the bend or trap. Check to find out whether a removable clean-out plug has been provided to make this job easier.

## **Sewer Gases**

When the clogging material has been removed from the trap, pour a pail or two of hot water into the drain to wash out any loose material. Check the strainer itself and clean it in hot water and soap in order to open all holes. The floor drain should be checked regularly, especially one that is not often used, since water in the trap may evaporate. This would allow sewer gases to enter the room. Pour a pail of water into the drain periodically in order to make certain of a proper water seal.

## **Unclogging Sinks**

Hair can often clog a bathroom sink and potato peels and other food waste will plug up kitchen sinks. Regardless of the obstruction, unclogging both sinks is done the same way.

Place a plunger over the clogged drain. Add enough water to cover the plunger lip and form a seal.

Plunge straight up and down several times and "*pop*" the plunger away. Repeat this method a few times to free the clog.

If the clog remains, position a bucket underneath the sink's trap. Unscrew each end of the trap and drain the water into the bucket.

Clean out any debris in the trap and if a kitchen sink has a disposer, disconnect and drain its waste line and clean out any debris.

If no significant debris is found in the sink lines, the clog is located in the sink's drain line or main waste line.

A clog in the main line will also plug other drains above it, and that needs to be cleared with a sewer snake.

## **Unclogging A Toilet**

**Use a "fluted" or funnel** plunger designed to seal inside a toilet bowl. Extend the fluted flap of the plunger; fit it tightly inside bowl drain to form a good seal.

Plunge up and down several times; to quickly break the seal. Repeat this a few times to work the clog back and forth and eventually free it.

If the clog remains, insert a closet auger into the bowl. Position the bent end of the auger into the bowl's trap and fish the rod through until it hits the clog.

Crank the auger's handle clockwise and push it into the clog a bit more. Once the clog is "hooked" with the spiral tip (or ball) pull the auger back and forth. Repeat these steps until the clog is freed.

Avoid flushing the toilet. It may still be clogged and backup. Instead, fill the bowl with a bucket. If the water level doesn't go down, the clog is still in the line.



## Drain-Waste-Vent (DWV) System

The drain-waste-vent system transports all the used water and waste from the house to the septic/sewer system. It's a network of drain pipes that runs to all the sinks, toilets, baths, showers, and washer.

Most new waste systems use rigid plastic PVC (polyvinyl chloride) or ABS (acrylonitrile butadiene styrene) pipe that are sealed with glue. Older homes generally have had cast iron pipe sealed with lead solder. However, today's homes may utilize cast iron pipe sealed with neoprene in some places as a way to avoid the noise plastic creates when water is draining through it.

The soil stack is the main component of the waste drain. It's a vertical "stack" of pipes that starts in the basement/crawlspace floor or wall where it's connected to the outbound sewer/septic line. The top end of the stack acts as a vent. It extends vertically out through the roof, allowing gases to escape outside and also helps promote drain flow by drawing air inward.

A plugged vent can trap dangerous gases and inhibits drainage; similar to plugging a drinking straw with your thumb to hold liquid.

Make sure the vent doesn't terminate in the attic. Trapped sewer gases can be dangerous, stink and cause serious structural problems. And a system without a vent may actually suck water out a sink's trap, or do the reverse and fill the sink with water when another fixture drains. A trap blocks sewer/septic gases. Without one, sewer gases can flow up the stack, drain pipes and come out wherever there's a drain.

A trap looks like a "U" and is installed below the drain. When water drains, the trap's shape causes a small amount of water to remain in the bend. That water blocks any gases from moving up the pipe and entering the room.

**NOTE:** Traps are needed on all drains. That is, sinks, tubs, showers, washers, and floor drains all need to have a trap in their drain lines. In most cases, a toilet has a built-in trap and doesn't require a trap in the drain line.

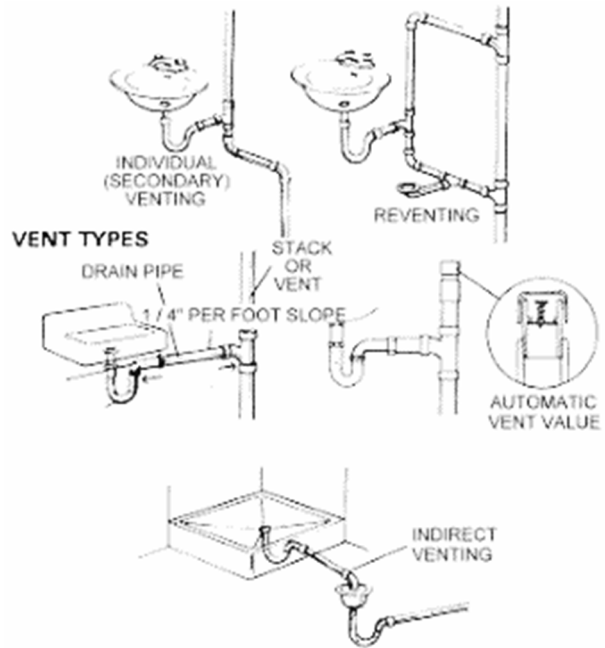



No Hub compression type fitting used on drain, waste and vent lines.

## Drain Waste Vent System Installation

### Most Common Mistakes

1. Violating or ignoring code restrictions,
2. Not installing D/W/V with at least a 1/4" slope per one foot pipe,
3. Not properly venting or trapping all fixtures,
4. Attaching too many fixtures to a drain or vent pipe,
5. Using pipes that are too small,
6. Not providing enough cleanouts or not providing cleanouts at the prescribed places,
7. Venting the fixture too far from the fixture's trap,
8. Not properly aligning tubing into fittings or stop valves. (Forcing the nut onto the compression ring at an angle when the tubing is at an angle will cause a leak.)
9. Using a fitting in a wrong position,
10. Installing rough plumbing in the wrong location,
11. Reducing pipe size as the pipes run downstream,
12. Cutting pipe too long and not allowing for the ridge in the fittings, and
13. Forcing the trap and waste arm fittings out of alignment and putting too much stress on the nuts and washers in the tubing.
14. Make certain the compression tubing is put in the fittings so that it is evenly tightened.

# Water Distribution System - Chapter 8

## Water Supply System

A house's water supply may come from a private well or a service pipe that connects to a city water main. In most cases, either water source is located in the basement/crawlspace.

A house with a private well utilizes a pump to push water up into a pressure tank where it is stored for use. When the tank empties, the pump is reactivated to fill the tank,

A house with city water has a "live" water supply line that's connected to a water main and a water meter. The meter is usually the dividing point between the city-owned lines and the homeowner's lines.

Both systems usually have a 1/2" or larger copper pipe that enters through the basement floor or wall. The line has a shut-off valve located near the beginning of the incoming line so the water supply can be stopped in case of repairs or an emergency.

Water supply lines are made of copper, CPVC (chlorinated polyvinyl chloride) plastic, or in older homes possibly galvanized steel. Cold water lines branch out from the main pipe, while hot water lines originate from the hot water heater.

System design depends on the area that you live. You may be a flatlander, like in Texas, and the services could be spread out for miles. You may live in the Rocky Mountain area and have many fluctuating elevations. Some areas may only serve residents on a part-time basis and water will sit for long periods of time, while other areas may have a combination of peaks and valleys with short and long distances of service. Before you design the system you need to ask yourself some basic questions.

- 1. What is the source of water?**
- 2. What is the population?**
- 3. What kind of storage will I need for high demand and emergencies?**
- 4. How will the pressure be maintained?**

## System Elements

The elements of a water distribution system include distribution mains, arterial mains, storage reservoirs, and system accessories. These elements and accessories are described as follows:

- **DISTRIBUTION MAINS** Distribution mains are the pipelines that make up the distribution system. Their function is to carry water from the water source or treatment works to users.
- **ARTERIAL MAINS** Arterial mains are distribution mains of large size. They are interconnected with smaller distribution mains to form a complete gridiron system.
- **STORAGE RESERVOIRS** Storage reservoirs are structures used to store water. They also equalize the supply or pressure in the distribution system. A common example of a storage reservoir is an aboveground water storage tank.

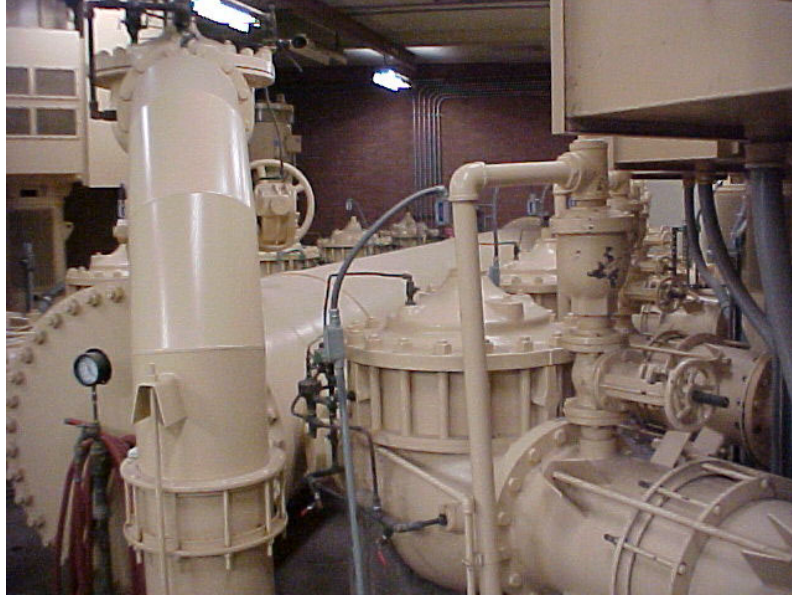

Booster Pump

***System accessories include the following:***

**BOOSTER STATIONS** - Booster stations are used to increase water pressure from storage tanks for low-pressure mains.

**VALVES** - Valves control the flow of water in the distribution system by isolating areas for repair or by regulating system flow or pressure.



Here a Gate Valve is prepared for a valve replacement.

Gate valves should be used in the distribution system for main line isolation.



## System Layouts

There are three general ways systems are laid out to deliver water (Picture your quarter section layouts). They include:

- A. Tree systems
- B. Loop or Grid systems
- C. Dead-end systems. ***Taste and odor problems.***

### Tree System

Older water systems frequently were expanded without planning and developed into a treelike system. This consists of a single main that decreases in size as it leaves the source and progresses through the area originally served. Smaller pipelines branch off the main and divide again, much like the trunk and branches of a tree.

A treelike system is not desirable because the size of the old main limits the expansion of the system needed to meet increasing demands. In addition, there are many dead ends in the system where water remains for long periods, causing undesirable tastes and odors in nearby service lines.

The most reliable means to provide water for firefighting is by designing redundancy into the system. There are several advantages gained by laying out water mains in a loop or grid, with feeder and distributor mains interconnecting at roadway intersections and other regular intervals.



Always remember to use shoring and proper safety equipment when working underground. You should also wear your hard hats as well. We are professionals and need to look like it. Bottom photograph is two nitwits going to be killed. 15 feet deep and no way out. Let's think "safety" before doing work.



## Distribution Valves

The purpose of installing shutoff valves in water mains at various locations within the distribution system is to allow sections of the system to be taken out of service for repairs or maintenance, without significantly curtailing service over large areas.

Valves should be installed at intervals not greater than 5,000 feet in long supply lines, and 1,500 feet in main distribution loops or feeders. All branch mains connecting to feeder mains or feeder loops should have valves installed as close to the feeders as practical. In this way, branch mains can be taken out of service without interrupting the supply to other locations.



In the areas of greatest water demand or when the dependability of the distribution system is particularly important, valve spacing of 500 feet may be appropriate.

At intersections of distribution mains, the number of valves required is normally one less than the number of radiating mains. The valve omitted from the line is usually the one that principally supplies flow to the intersection. Shutoff valves should be installed in standardized locations (that is, the northeast corner of intersections or a certain distance from the center line of streets), so they can be easily found in emergencies. All buried small- and medium-sized valves should be installed in valve boxes. For large shutoff valves (about 30 inches in diameter and larger), it may be necessary to surround the valve operator or entire valve within a vault or manhole to allow repair or replacement.

## Classification of Valves

There are two major classifications of water valves: **Rotary and Linear**. Linear is a fancy word for up and down or blade movement.

**Gate Valve Linear Valve** *Our primary Linear valve*

**The most common valve in the distribution system. Primarily used for main line shut downs. Should be exercised on annual basis.**

Gate valves are used when a straight-line flow of fluid and minimum flow restriction are needed. Gate valves are so-named because the part that either stops or allows flow through the valve acts somewhat like a gate.



The gate is usually wedge-shaped. When the valve is wide open the gate is fully drawn up into the valve bonnet. This leaves an opening for flow through the valve the same size as the pipe in which the valve is installed.

Therefore, there is little pressure drop or flow restriction through the valve. Gate valves are not suitable for throttling purposes. The control of flow is difficult because of the valve's design, and the flow of fluid slapping against a partially open gate can cause extensive damage to the valve. Except as specifically authorized, gate valves should not be used for throttling.





## Valve Glossary

Here are some of the common valves and related information.

**Air and Vacuum relief valve:** Both of these functions are in one valve. These valves can combine three functions; they can allow large amounts of air to escape during the filling of a pipeline, permits air to enter a pipeline that is being drained and allow entrained air to escape while a line is operating under pressure. Distribution system water quality can be adversely affected by improperly constructed or poorly located blowoffs of vacuum/air relief valves. Air relief valves in the distribution system lines must be placed in locations that cannot be flooded. This is to prevent water contamination. The common customer complaint of Milky Water is sometimes solved by the installation of these air relief valves.

**Altitude valve:** Are often used on supply lines to elevated tanks or standpipes. These close automatically when the tank is full and open when the pressure on the inlet side is less than that on the tank side of the valve. These valves control the high water level and prevent overflow. Altitude-Control Valve is designed to, 1. Prevent overflows from the storage tank or reservoir, or 2. Maintain a constant water level as long as water pressure in the distribution system is adequate.

**Butterfly valve:** Has a movable disc as large as the full bore opening of the valve.

**Check valve:** Are often used on the discharge side of pumps to prevent backflow.

**Gate valve:** Is a linear valve used to isolate sections of the water main, to permit emergency repairs without interruption of water service to customers.

**Pressure sustaining valve:** Maintains constant downstream pressure regardless of fluctuating demand. The valve is usually a globe design controlled by a diaphragm with the diaphragm assembly being the only moving part in the valve. Can also be used as an automatic flow-control valve.

**Pressure regulating valve:** A valve that controls water pressure by restricting flows. The pressure downstream of the valve regulates the amount of flow. Usually these valves are of the globe valve design. **Pressure Regulation Valves** control water pressure and operate by restricting flows. They are used to deliver water from a high pressure to a low-pressure system. The pressure downstream from the valve regulates the amount of flow. Usually, these valves are of the globe design and have a spring-loaded diaphragm that sets the size of the opening.

**Pressure relief:** The simplest type of surge pressure relief is a pressure relief valve. These valves respond to pressure variations at their inlets.

**What screen size and protection should air vacuum release valves have above and below ground?**

Vents should be screened to keep out birds and animals that may contaminate the water. A screen with 1/4 mesh openings is required. Some vents have flap valves that will operate to relieve excess pressure or vacuum if the screen becomes blocked.

**What types of water contamination problems could result from improper installation of air vacuum and relief valves?**

All overflow, blow off, or cleanout pipes should be turned downward to prevent entrance of rain and should have removable #24-mesh screens to prevent the entrance of birds, insects, rodents, and contaminating materials.



## **The Singing Key**

Dr. Rusty recommends that you listen to the Valve Key when shutting down a Gate valve. You will easily hear it sing as you shut the water off or leak by. It is very easy to create a water hammer when opening or closing a Gate valve. Always take your time when operating a Gate valve or any valve. I know that most of you will not listen to me and you will end up breaking plastic water services and customer's water lines at first. Next, you'll move up to water main breaks. We like to blame the Fire Department or Street Sweepers for water hammers, and they should be blamed, but most water hammers are created by water personnel. Yes, I said it. A great example is watching a rookie shut down or open a fire hydrant. These young rookies like to turn the hydrant on or off as fast as possible, like the Firemen do. Pretty soon, the hydrant starts chattering and pumping. The ground feels like an earthquake and the rookie pretends that nothing is happening. We've all done this and if you haven't, you've probably never worked in the field.

## **Problems**

### **Valve Jammed Open**

Dr. Rusty recommends that opened valves should not be jammed-tight on the backseat.

Always back the valve-off a quarter turn from the fully opened position.

Note that motor operated valves coast inevitably to the backseat by tripping on a limit switch. Valves should not be back seated on torque.

### **Valve Jammed Closed**

Variations in the temperature and/or pressure of the working fluid are often the cause of a valve failing to open.

Thermal binding can occur in high temperature situations depending on the seat and wedge material, length of exposure and closing torque applied. Thermal binding can cause galling on the valve sealing surfaces as well as on the guides.

A valve can lock in the closed position when high pressure enters the cavity and has no way to escape. This is known as over-pressurization.

### **If Excessive Torque is Needed to Work the Valve**

Variations in the temperature and/or pressure of the working fluid are often the cause of a valve failing to open.

Thermal binding can occur in high temperature situations depending on the seat and wedge material, length of exposure and closing torque applied. Thermal binding can cause galling on the valve sealing surfaces as well as on the guides.

A valve can lock in the closed position when high pressure enters the cavity and has no way to escape. This is known as over-pressurization. We will cover this in a later section.

Single direction sealing gate valves have a nameplate on the side of the valve that has a relief hole or pressure equalizer. This should be the high pressure side when the valve is closed.



**Notice the corrosion inside this cast iron main.**

This corrosion is caused by chemical changes produced by electricity or electrolysis. We call this type of corrosion tuberculation. It is a protective crust of corrosion products that have built up over a pit caused by the loss of metal, due to corrosion or electrolysis.

This type of corrosion will decrease the C-Factor and the carrying capacity in a pipe. Crenothrix bacteria or Red-Iron bacteria will live in the bioslime in this type of tuberculation. Now for dealing with this nasty bacteria—there are two methods: the fast method, super chlorinate and flush forever. Or, replace the line with a nice plastic water main.



Gate valve storage procedures. Dr. Rusty recommends to always store a gate valve with the gate up or opened. Not like this picture. Sunlight will give the rubbers a good shot of Vitamin D and a sunburn, destroying the rubbers with ultraviolet radiation. I like to keep the valves covered and clean and I want you to do the same. I know that some of you don't care because these valves are so darn heavy and bother-some. We are professionals and must remember the final outcome. We provide drinking water to the public. Notice the two different styles of flange fittings.

### Knife Gate Valve

Always follow standard safety procedures when working on a valve. Install the valve so that the arrows on both sides of the body are in the direction of positive pressure differential.

The preferred orientation is with the stem vertical and the handwheel pointing up. The opposite orientation is not recommended, because fiber and dirt can build-up in the bonnet.

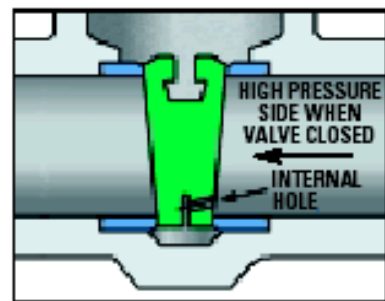

Service connections are used to connect individual buildings or other plumbing systems to the distribution system mains. See the Angle stop.

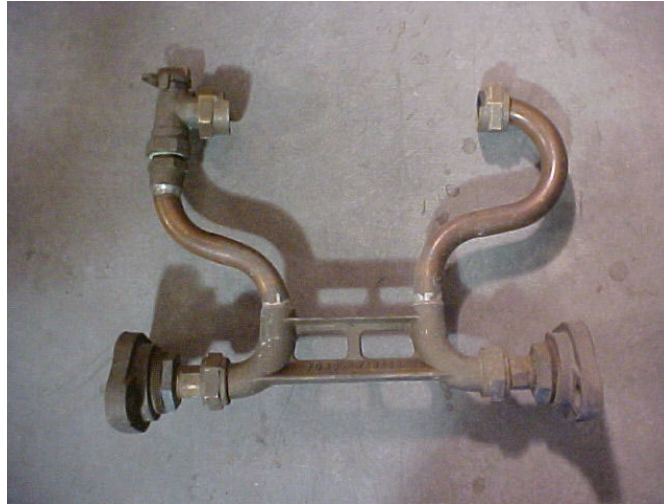

Water Meter Re-setter, Riser, or sometimes referred to as a copper yoke. There is also a cast iron version which is best broken off with two sledge or cocking hammers when it's time to replace or retrofit the service. You almost always replace a yoke stop hot. A Yoke stop is an Angle Stop most of the time but I've seen a nasty galvanized valve that is also used in this situation.



Common distribution fittings: Single check, Poly Pig, 1 inch repair clamp, 4 inch full circle clamp, T- Bolt and a corp. and saddle. Note from Dr. Rusty, Single checks are not a backflow assembly and will probably stick open over time. I know that most systems will pay for these but unless you replace or test these checks, they will not hold up. Most fitting salesmen will not tell you this little tidbit. Notice the Corp, it is a ball type valve.



Ductile pipe cement-lined iron pipe. I've seen thousands of dollars of pipe that is dropped or moved with the front bucket of a backhoe and destroyed. This destroys the interior protection of the pipe, causing leaks which will start in a few years. I know that some of you welcome this as job security. These nitwits need job security, but water professionals do not need crappy work to keep them employed. Always protect and store all types of pipe covered in a pipe rack. This goes for the proper storage of rubbers as well.



Flex Coupling--sometimes referred to as a Dayton; used to join pipes or to "cut-in a valve." You will learn that you can use different sizes to join pipe or even file out the inside diameter to adjust to larger pipes like ACP. This flex coupling only has three bolts. I like four or more for work with larger pipe work. Dr. Rusty's trick, when working on a water line, I like to turn the valves on slowly to fill the water main as the flex couplings are being tightened. This allows the air to escape and for you to find leaks. It also allows debris in the main to flush out.



Here is a four-way pipe cutting tool used for iron pipe. Be careful not to break the wheels by over-tightening. I personally like 4-Ways because of the nice cut. You will learn to recognize the distinct snap of cut pipe. The only drawback to these cutters is cutting a small section out of the main. You may need to make two or three more cuts and break the section out with a cocking hammer. It will easily cut ductile, galvanized, and even plastic. Plastic pipe cutters utilize sharper cutting wheels. Rookies like to thread the pipe rather than cut the pipe. It is fun to watch and good to tease these rookies about it. Especially if they have just finished jumping a stop with the valve closed or no ball. Good times for sure in the crazy Distribution field.

Photograph on right, difficult to see, these are pipe crimpers. These will easily and effectively stop flow in copper or plastic pipe in tubing less than 2 inches. The only problem is dealing with the crimp when you are finished. I suggest placing a flex coupling over the crimp in plastic and completely cutting the crimped area out when done in copper pipe.







Top photograph, two gate valves blew out, you can see the kickers or thrust blocks in the back ground. Bottom photograph, a tapping machine and a new gate valve. These tapping machines are very, very expensive.



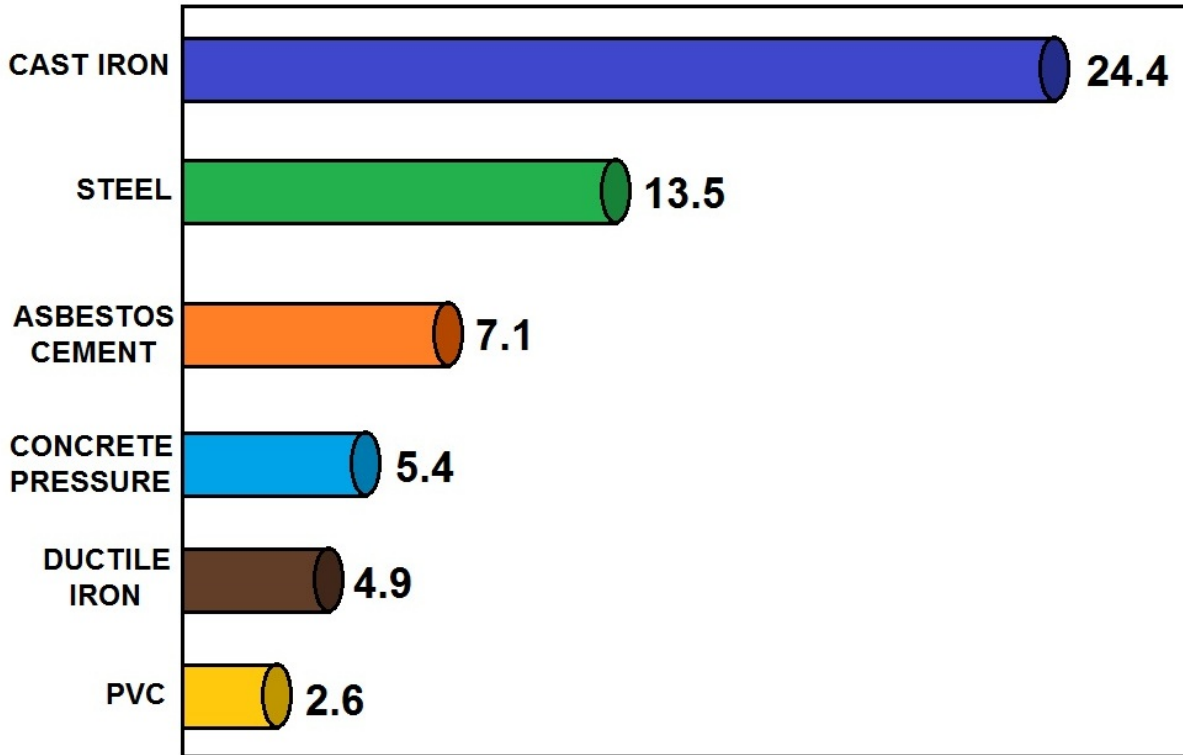

## WATER MAIN BREAKS

RATES REFLECT # OF BREAKS PER 100 MILES OF INSTALLED PIPE

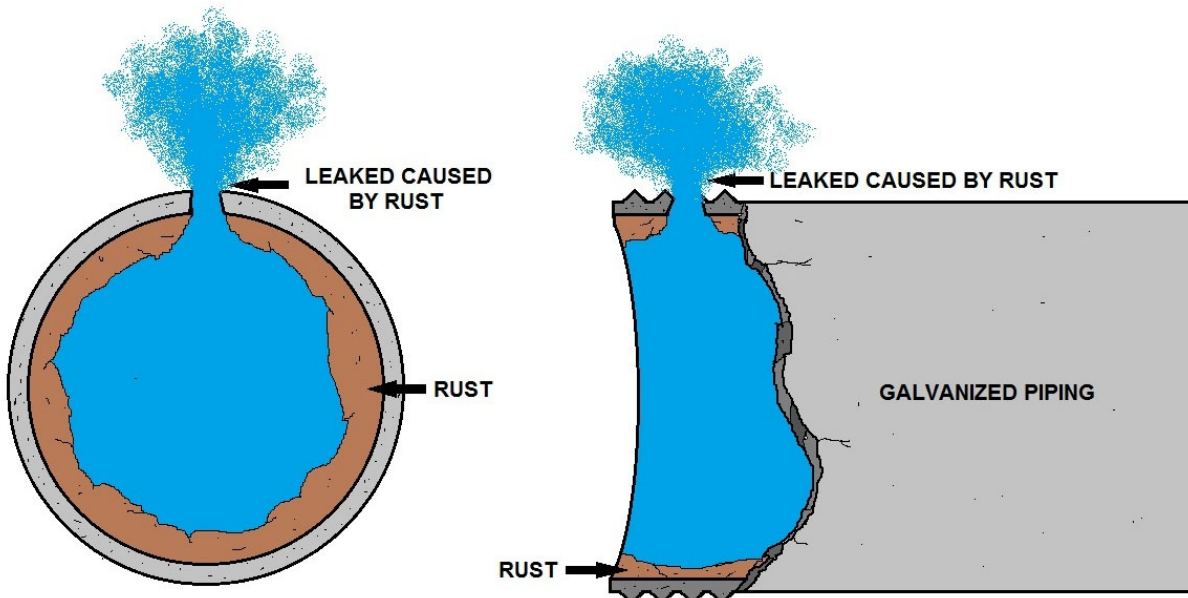

**ELECTROLYSIS CREATING A HOLE OR BREAK IN IRON BASED WATER MAINS**

## Common Rotary Valves

### Globe Valve Rotary Valve

Primarily used for flow regulation, and works similar to a faucet. They are rare to find in most distribution systems, but can be found at treatment plants. Always follow standard safety procedures when working on a valve. Most Globes have compact OS & Y type, bolted bonnet, rising stems, with renewable seat rings. The disc results with most advanced design features provide the ultimate in dependable, economical flow control.

Globe valves should usually be installed with the inlet below the valve seat. For severe throttling service, the valve may be installed so that the flow enters over the top of the seat and goes down through it. Note that in this arrangement, the packings will be constantly pressurized. If the valve is to be installed near throttling service, verify with an outside contractor or a skilled valve technician. Globe valves, per se, are not suitable for throttling service.

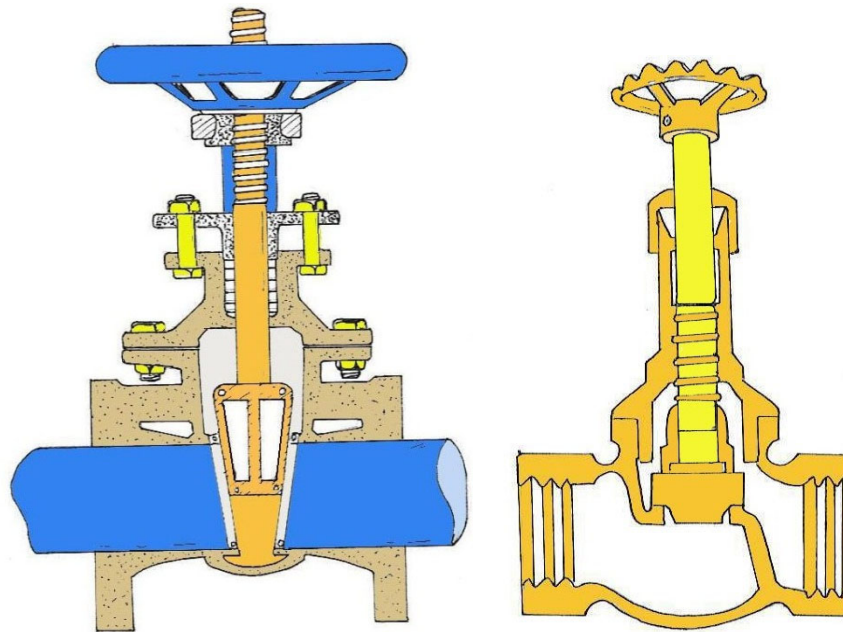

### RISING STEM & GLOBE VALVE DIAGRAM

The valve should be welded onto the line with the disc in the fully closed position. Leaving it even partially open can cause distortion and leaking. Allow time for the weld to cool before operating the valve the first time in the pipeline. The preferred orientation of a globe valve is upright. The valve may be installed in other orientations, but any deviation from vertical is a compromise. Installation upside down is not recommended because it can cause dirt to accumulate in the bonnet.

### Globe Valve Problems and Solutions

**If the valve stem is improperly lubricated or damaged--** Disassemble the valve and inspect the stem. Acceptable deviation from theoretical centerline, created by joining center points of the ends of the stem is 0.005"/ft of stem. Inspect the threads for any visible signs of damage. Small grooves less than 0.005" can be polished with an Emory cloth.

Contact specialized services or an outside contractor if run-out is unacceptable or large grooves are discovered on the surface of the stem.

**If the valve packing compression is too tight**--Verify the packing bolt torque and adjust if necessary.

**Foreign debris is trapped on threads and/or in the packing area**--This is a common problem when valves are installed outdoors in sandy areas and areas not cleaned before operating.

Always inspect threads and packing area for particle obstructions; even seemingly small amounts of sand trapped on the drive can completely stop large valves from cycling. The valve may stop abruptly when a cycle is attempted. With the line pressure removed from the valve, disconnect the actuator, gear operator or handwheel and inspect the drive nut, stem, bearings and yoke bushing. Contaminated parts should be cleaned with a lint-free cloth using alcohol, varsol or equivalent. All parts should be re-lubricated before being re-assembled. If the valves are installed outdoors in a sandy area, it may be desirable to cover the valves with jackets.

**If the valve components are faulty or damaged**--contact specialized services or an outside contractor.

**If the valve's handwheel is too small**--Increasing the size of the handwheel will reduce the amount of torque required to operate the valve. If a larger handwheel is installed, the person operating the valve must be careful not to over-torque the valve when closing it.



## Bellow Seal Valve

Always follow standard safety procedures when working on a valve.

Bellows seal valves provide a complete hermetic seal of the working fluid. They are used in applications where zero leakage of the working fluid into the environment is permitted.

Bellows seal valves are specially modified versions of the standard valves. The installation information that applies to gate and globe valves will apply to bellows seal valves.

A packing leak signifies that the bellows has ruptured or the bellows-assembly weld has a crack. Dr. Rusty does not recommend repairing or reusing a damaged bellows. Instead, Dr. Rusty suggests replacing the entire bonnet assembly including bellows and stem.

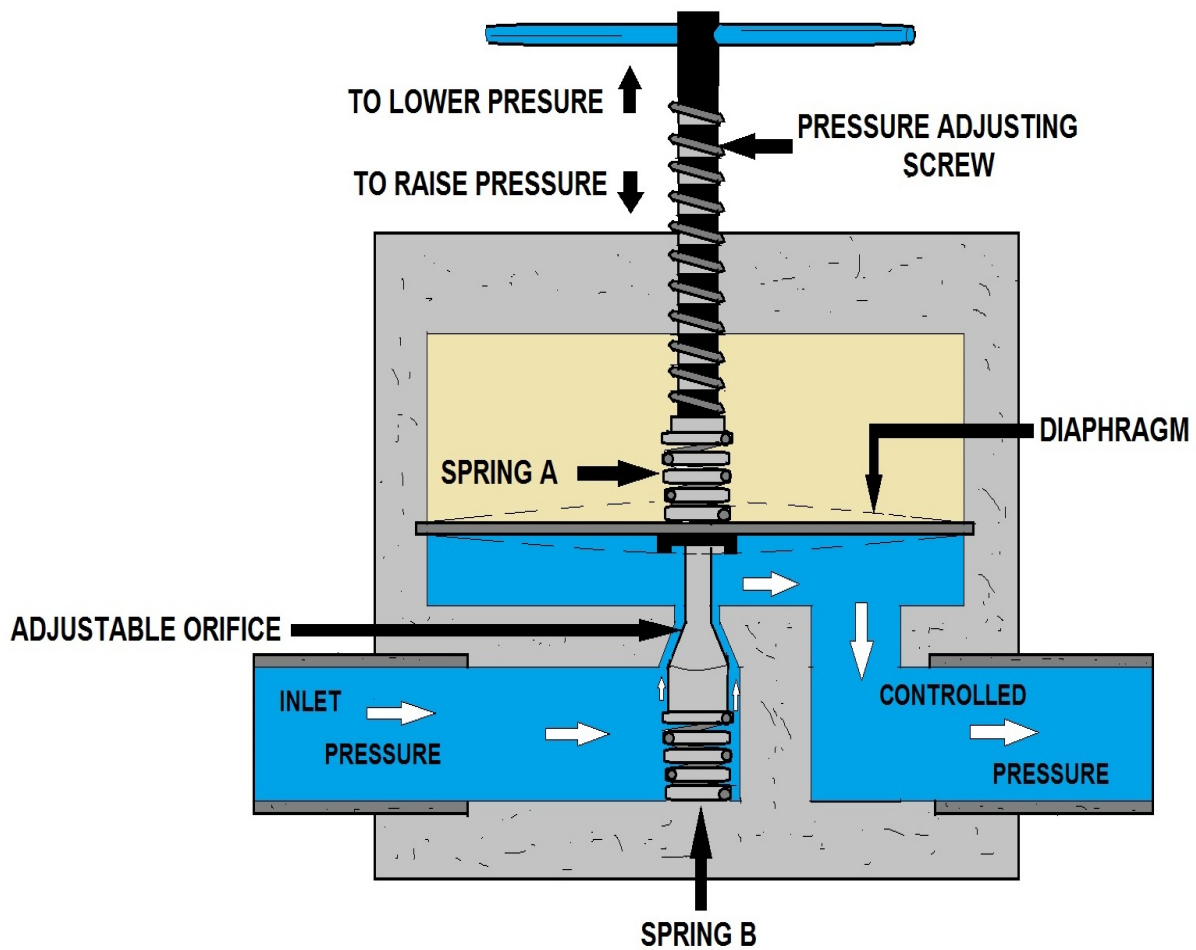

**PRESSURE-REGULATING VALVE**

### **Pressure Sustaining Valve**

Pressure sustaining valves are used to sustain the system pressure to a predetermined maximum level. The applications balance the pressure distribution throughout the whole system by maintaining the minimum pressure for high altitude users. Pressure sustaining valves are also used to prevent discharging of the pipe system when any user starts to operate. More in a few more pages.

### **Pressure Reducing Valve**

Pressure reducing valves maintain a predetermined outlet pressure which remains steady and unaffected by either changing of inlet pressure and/or various demands. Pressure Reducing Valves are self-contained control valves which do not require external power. More in a few more pages.

### **Insertion Valves Rotary Valve**

You know sometimes you can obtain a shut down and you have two choices. Do it hot or cut in an insertion or inserting valve. An Insertion valve is normally a Gate Valve that is made to be installed on a hot water main. A few years ago, this was a serious feat. First, you had to pour ten yards of mud or cement and come back and cut the valve in. No longer. The Insertion valve machine and tap works like a tapping sleeve. The only difference is that the tap points up and not to the side. I recommend that any major system budget money to purchase this equipment. It will pay for itself on the first job. Otherwise, contract the work out. You can see in the photograph a manually operated tapping machine. I prefer the electric. Note: see the sweet shoring shield set-up. It is rare to see a nice shoring job.



Hydro-Stop valve insertion machine

### Needle Valves *Rotary Valve*

A needle valve, as shown on the right, is used to make relatively fine adjustments in the amount of fluid flow. The distinguishing characteristic of a needle valve is the long, tapered, needle-like point on the end of the valve stem. This "needle" acts as a disk. The longer part of the needle is smaller than the orifice in the valve seat and passes through the orifice before the needle seats. This arrangement permits a very gradual increase or decrease in the size of the opening. Needle valves are often used as component parts of other, more complicated valves. For example, they are used in some types of reducing valves.

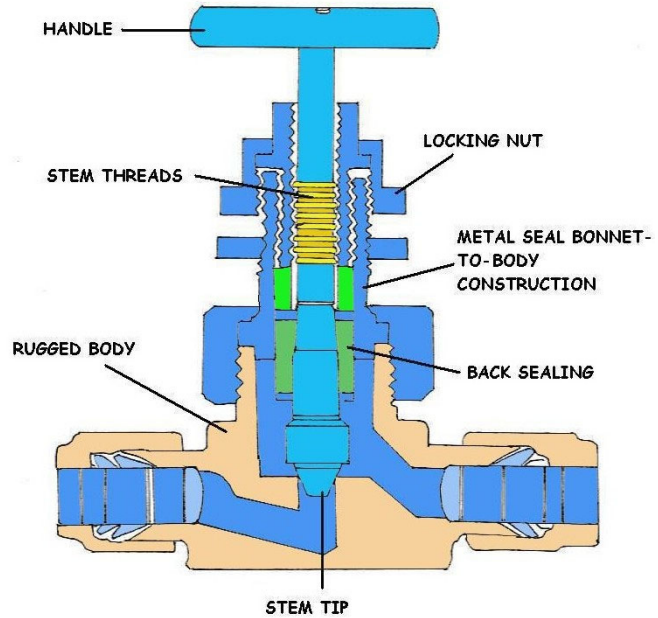

**NEEDLE VALVE**

### Plug Valves *Rotary Valve*

Plug valves are extremely versatile valves that are found widely in low-pressure sanitary and industrial applications, especially petroleum pipelines, chemical processing and related fields, and power plants. They are high capacity valves that can be used for directional flow control, even in moderate vacuum systems. They can safely and efficiently handle gas and liquid fuel, and extreme temperature flow, such as boiler feed water, condensate, and similar elements. They can also be used to regulate the flow of liquids containing suspended solids (slurries).

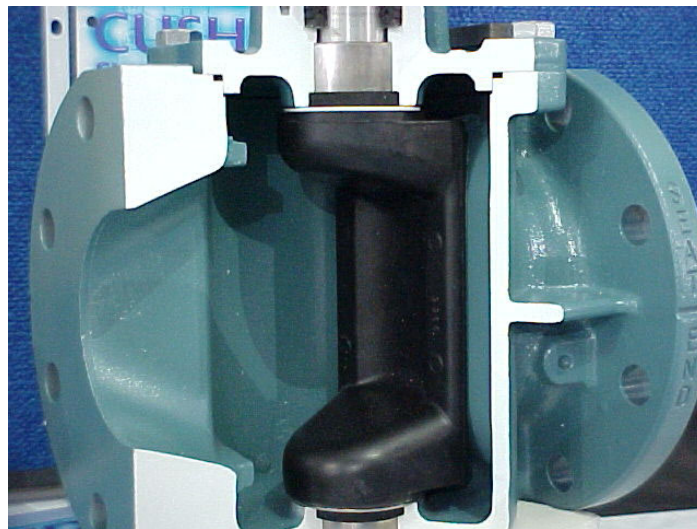

Cut-away of a Plug Valve

### **Angle Stop Rotary Valve**

When working in tight areas, you sometimes need a tight fitting valve. This is an excellent place for an Angle Stop or Angle valve. If you ever have to jump an Angle valve on hot, first dismantle the bottom compression fitting and the rubber and slide it on the water line. Sometimes the bottom compression fitting will have a set-screw and some operators like to tighten it to the pipe or service before jumping the stop. Either way, it will work. Always have a helper if jumping any service larger than 1 inch.



Get in there and jump that corp!



## **Ball or Corporation Stop Rotary Valve Small Valves 2 inches and smaller**

Most commonly found on customer or water meters. All small backflow assemblies will have two Ball valves. It is the valve that is either fully on or fully off; and the one that you use to test the abilities of a water service rookie. The best trick is to remove the ball from the Ball valve and have a rookie **Jump a Stop**. The Corp is usually found at the water main on a saddle. Some people say that the purpose of the Corp is to regulate the service. I don't like that explanation. No one likes to dig up the street to regulate the service, and Ball valves are only to be used fully on or fully off.



Most ball valves are the quick-acting type. They require only a 90-degree turn to either completely open or close the valve. However, many are operated by planetary gears. This type of gearing allows the use of a relatively small handwheel and operating force to operate a fairly large valve. Always follow standard safety procedures when working on a valve.

The gearing does, however, increase the operating time for the valve. Some ball valves also contain a swing check located within the ball to give the valve a check valve feature. The brass ball valve is often used for house appliance and industry appliance, the size range is 1/4"-4". Brass or zinc is common for body, brass or iron for stem, brass or iron for ball, aluminum, stainless steel, or iron for handle including a Teflon seal in the ball housing.



Flush the pipeline before installing the valve. Debris allowed to remain in the pipeline (such as weld spatters, welding rods, bricks, tools, etc.) can damage the valve. After installation, cycle the valve a minimum of three times and re-torque bolts as required. Ensure that the valve is in the open position and the inside of the body bore of the valve body/body end is coated with a suitable spatter guard.



Bird's eye view of the coveted stainless steel ball.



Removing the ball is very difficult. I think they use a robot to tighten the rear nut to keep you from removing it. I recommend that you always use pipe dope or Teflon tape when installing a Stop. I know a lot of you think that brass or bronze will make up the slack, but pipe dope, or Teflon dope or tape makes a nicer job and makes for an easier removal.

## Butterfly Valve Rotary Valve

Usually a huge water valve found in both treatment plants and throughout the distribution system. If the valve is not broken, it is relatively easy to operate. It is usually accompanied with a Gate valve used as a by-pass to prevent water hammer. When I was a Valve man, it seemed that every Bypass valve was broken closed when near a Butterfly valve.

These are rotary type of valves usually found on large transmission lines. They may also have an additional valve beside it known as a **"bypass valve"** to prevent a water hammer.

Some of these valves can require 300-600 turns to open or close. Most Valvemen (or the politically correct term "Valve Operators") will use a machine to open or close a Butterfly Valve. The machine will count the turns required to open or close the valve.

Butterfly valves should be installed with the valve shaft horizontal or inclined from vertical. Always follow standard safety procedures when working on a valve.

The valve should be mounted in the preferred direction, with the "HP" marking. Thermal insulation of the valve body is recommended for operating temperatures above 392°F (200°C).

The valve should be installed in the closed position to ensure that the laminated seal in the disc is not damaged during installation.

If the pipe is lined, make sure that the valve disc does not contact the pipe lining during the opening stroke. Contact with lining can damage the valve disc.

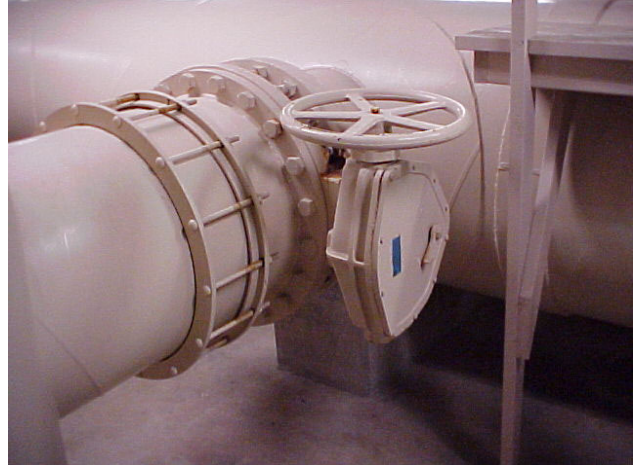

54 inch Butterfly valve on a huge transmission line. Nice job but no shoring, no ladder or valve blocking.



## FEATURES & ADVANTAGES

AWWA C504, CLASS 150B, BUTTERFLY VALVES

### BODY

Heavy duty cast iron furnished standard, with ductile iron available as an extra cost option. Flanged Valves are faced and drilled per ANSI B16.1, Class 125. Mechanical Joint Valves are machined per ANSI/AWWA C111A21.11. Wafer Valves are machined to fit between ANSI B16.1, Class 125 flanges.

### SHAFT

Corrosion resistant stainless steel per ASTM A276 Type 304 furnished standard or type 316 furnished as an extra cost option. One piece design on valves sizes 2" to 8" and two piece design 10" and up. Shafts are sized to meet AWWA C504 for Class 150B Butterfly Valves.

### BEARINGS

(Upper and Lower)  
Fiberglass reinforced nylon bearings are low friction, self-lubricating and provide exceptionally long life.

### DISC

Corrosion resistant ASTM A276, Type 316 stainless steel sizes 3", 4" and 6". High strength ASTM-A536, 65-45-12, ductile iron with a 316 stainless steel edge per AWWA C504 and fusion bond epoxy coating on sizes 8" and up. Streamlined lens-shaped disc provides minimum headloss. Discs are attached to shafts with 316 stainless steel tapered dowel pins.

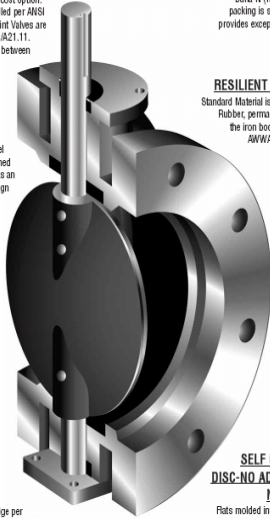

### SHAFT SEALS

(Upper and Lower)  
Buna-N (Nitrile) Chevron V backing is self adjusting and provides exceptionally long life.

### RESILIENT BODY SEAT

Standard Material is Buna-N (Nitrile) Rubber, permanently bonded to the iron body and tested per AWWA Standard C504.

### SELF CENTERING DISC-NO ADJUSTMENT NECESSARY

Flats molded into the vulcanized rubber body seat mate with machined flats on the disc to provide positive centering of the disc in the body. Accurate centering of the disc in the body assures maximum seat life.

**AWWA STANDARD C-504 BUTTERFLY VALVES**

**FLANGED WITH WORM GEAR ACTUATOR & HANDWHEEL**

**WAFER WITH 10 POSITION LEVER**

**FLANGED WITH TRAVELING NUT ACTUATOR & 2" SQ. NUT**

Bulletin BF150-2

**GA Industries Inc.**  
MANUFACTURERS OF GOLDEN ANGELOP VALVES

# ACTUATION METHODS

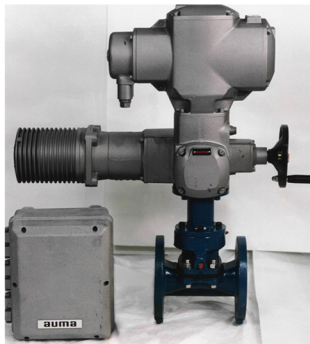

- Standard Handwheel
- Chainwheel Operated
- Square Nut
- Pneumatic
- Electric

## Butterfly Valve Problems

A butterfly valve may have jerky operation for the following reasons:

**If the packing is too tight**--Loosen the packing torque until it is only hand tight. Tighten to the required level and then cycle the valve. Re-tighten, if required. CAUTION: Always follow safety instructions when operating on valve.

**If the shaft seals are dirty or worn out**--Clean or replace components, as per assembly-disassembly procedure. CAUTION: Always follow safety instructions when operating on a valve.

**If the shaft is bent or warped**--The shaft must be replaced. Remove valve from service and contact an outside contractor or your expert fix-it person.

**If the valve has a pneumatic actuator, the air supply may be inadequate**--Increase the air supply pressure to standard operating level. Any combination of the following may prevent the valve shaft from rotating:

**If the actuator is not working**--Replace or repair the actuator as required. Please contact specialized services or an outside contractor for assistance.

**If the valve is packed with debris**--Cycle the valve and then flush to remove debris. A full cleaning may be required if flushing the valve does not improve valve shaft rotation. Flush or clean valve to remove the debris.



A broken 54 inch Butterfly and a worker inside the water main preparing the interior surface. Notice, this is a Permit Required Confined Space. Hot work permit is also required. Side note, there is a plastic version of the 54 and 60 inch Butterfly valve.



Here at a water treatment plant, we can see both valve actuators control devices and Butterfly valves as well. Bottom photograph is a cut-away of an actuator.

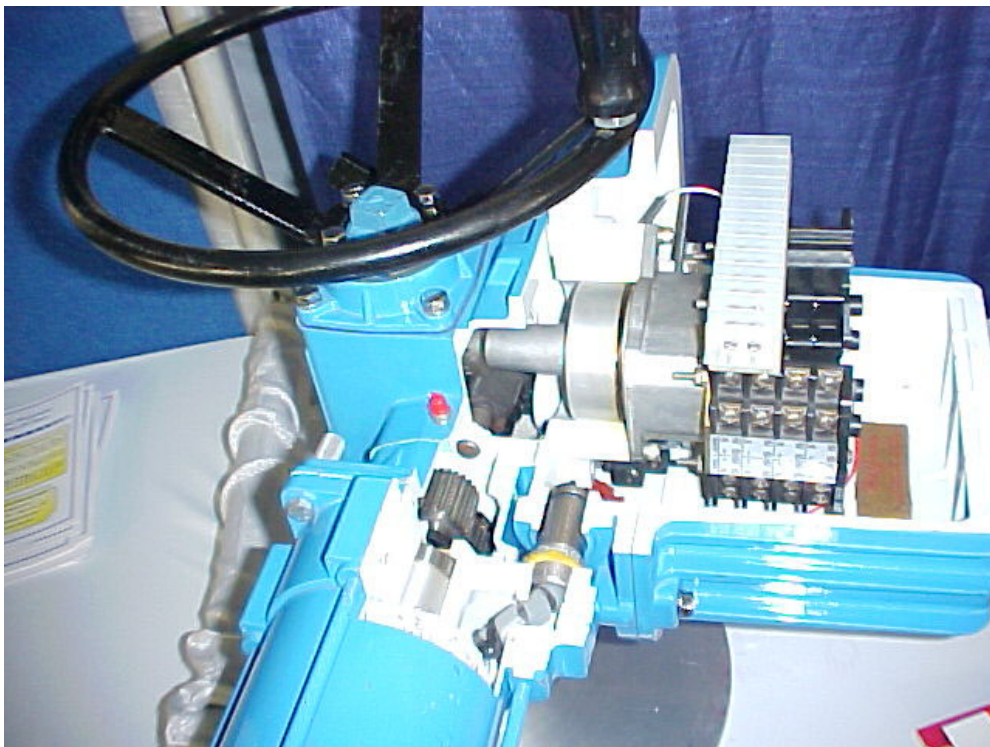

## Actuators and Control Devices

Directional control valves route the fluid to the desired actuator. They usually consist of a spool inside a cast iron or steel housing. The spool slides to different positions in the housing, and intersecting grooves and channels route the fluid based on the spool's position.

The spool has a central (neutral) position maintained with springs; in this position the supply fluid is blocked, or returned to tank. Sliding the spool to one side routes the hydraulic fluid to an actuator and provides a return path from the actuator to the tank. When the spool is moved to the opposite direction, the supply and return paths are switched. When the spool is allowed to return to the neutral (center) position the actuator fluid paths are blocked, locking it in position.

Directional control valves are usually designed to be stackable, with one valve for each hydraulic cylinder, and one fluid input supplying all the valves in the stack.

Tolerances are very tight in order to handle the high pressure and avoid leaking; spools typically have a clearance with the housing of less than a thousandth of an inch. The valve block will be mounted to the machine's frame with a three point pattern to avoid distorting the valve block and jamming the valve's sensitive components.

The spool position may be actuated by mechanical levers, hydraulic pilot pressure, or solenoids which push the spool left or right. A seal allows part of the spool to protrude outside the housing, where it is accessible to the actuator.

The main valve block is usually a stack of off the shelf directional control valves chosen by flow capacity and performance. Some valves are designed to be proportional (flow rate proportional to valve position), while others may be simply on-off. The control valve is one of the most expensive and sensitive parts of a hydraulic circuit.

Pressure relief valves are used in several places in hydraulic machinery: on the return circuit to maintain a small amount of pressure for brakes, pilot lines, etc.; on hydraulic cylinders, to prevent overloading and hydraulic line/seal rupture; on the hydraulic reservoir, to maintain a small positive pressure which excludes moisture and contamination.

**Pressure reducing valves reduce the supply pressure as needed for various circuits.**

Sequence valves control the sequence of hydraulic circuits; to insure that one hydraulic cylinder is fully extended before another starts its stroke, for example.

Shuttle valves provide a logical function.

Check valves are one way valves, allowing an accumulator to charge and maintain its pressure after the machine is turned off, for example.

Pilot controlled Check valves are one way valves that can be opened (for both directions) by a foreign pressure signal. For instance, if the load should not be held by the check valve anymore. Often the foreign pressure comes from the other pipe that is connected to the motor or cylinder.

**Counterbalance valves.** A counterbalance valve is, in fact, a special type of pilot controlled check valve. Whereas the check valve is open or closed, the counterbalance valve acts a bit like a pilot controlled flow control.

Cartridge valves are, in fact, the inner part of a check valve; they are off the shelf components with a standardized envelope, making them easy to populate a proprietary valve block. They are available in many configurations: on/off, proportional, pressure relief, etc. They generally screw into a valve block and are electrically controlled to provide logic and automated functions. Hydraulic fuses are in-line safety devices designed to automatically seal off a hydraulic line if pressure becomes too low, or safely vent fluid if pressure becomes too high.

**Auxiliary valves.** Complex hydraulic systems will usually have auxiliary valve blocks to handle various duties unseen to the operator, such as accumulator charging, cooling fan operation, air conditioning power, etc... They are usually custom valves designed for a particular machine, and may consist of a metal block with drilled ports and channels. Cartridge valves are threaded into the ports and may be electrically controlled by switches or a microprocessor to route fluid power as needed.

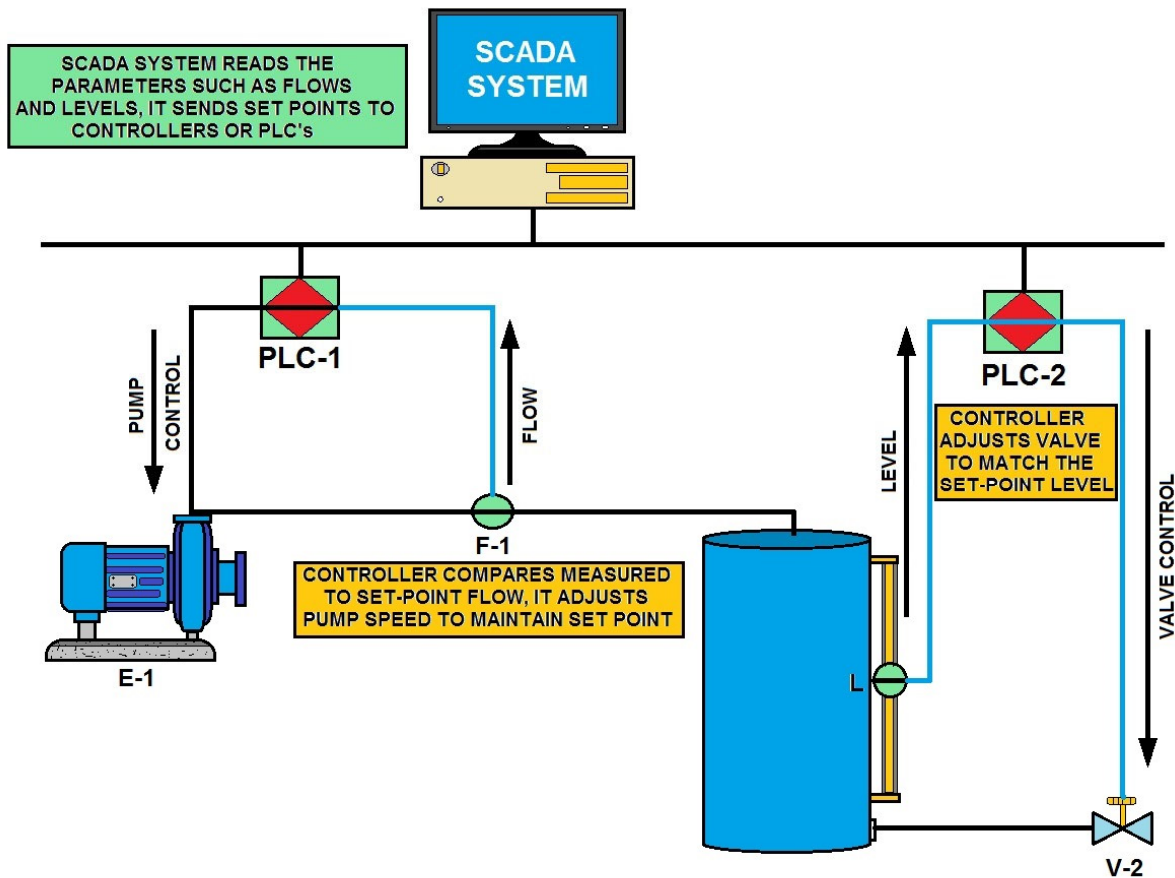

**SCADA SYSTEM**  
(SUPERVISORY CONTROL and DATA ACQUISITION)



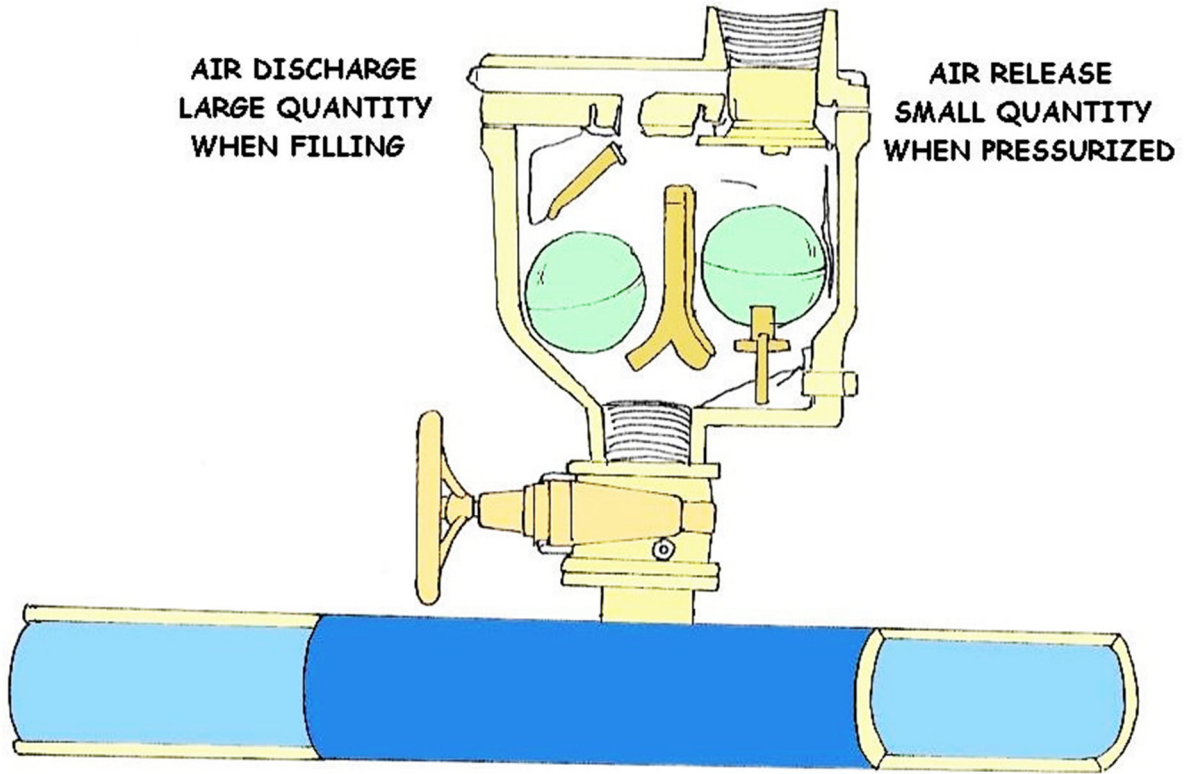

**COMBINATION AIR RELIEF VALVE DIAGRAM**

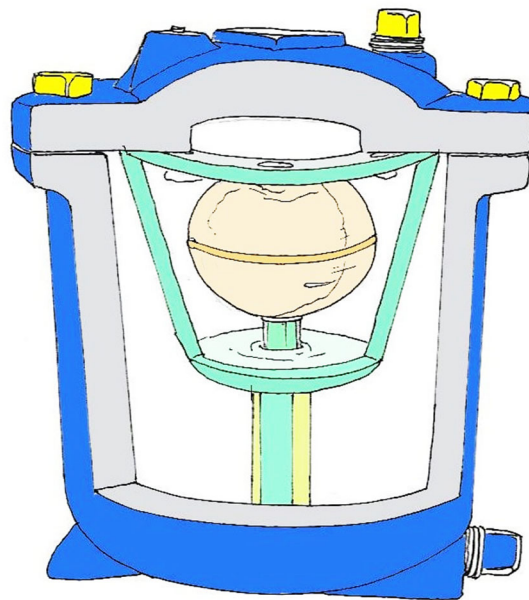

**INTERNAL VIEW OF AIR RELIEF VALVE DIAGRAM**

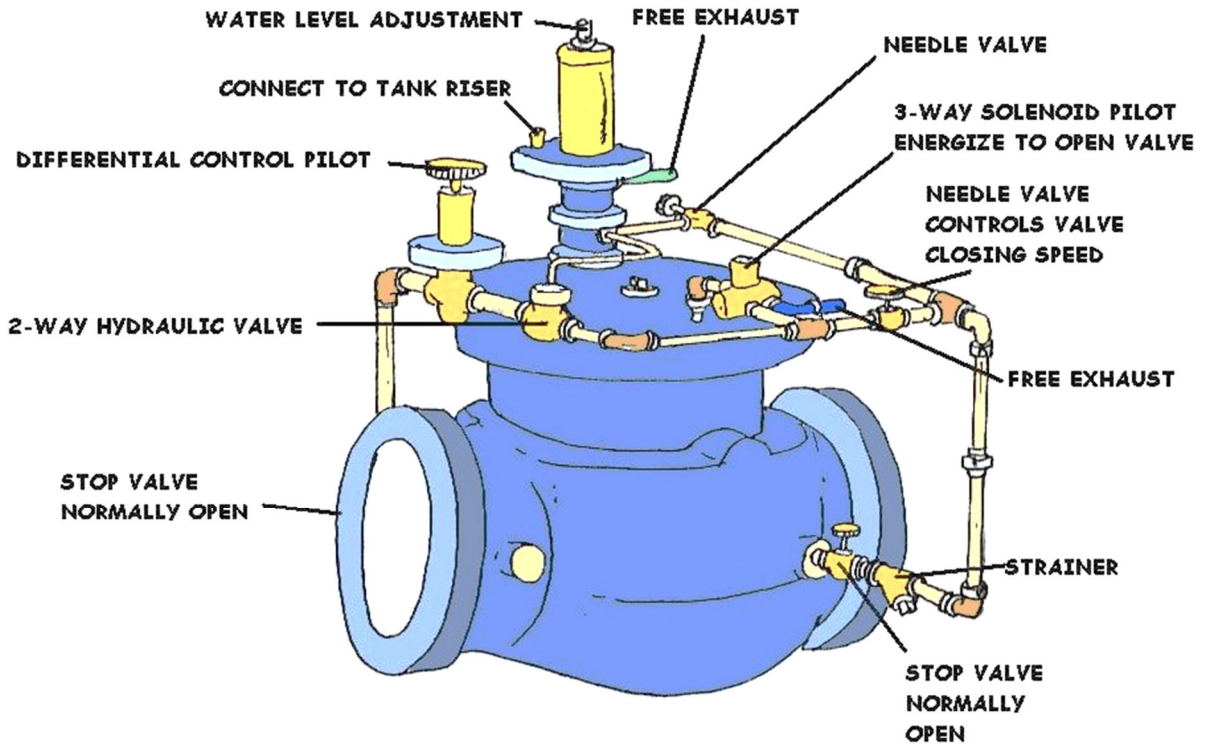

**ALTITUDE CONTROL VALVE**

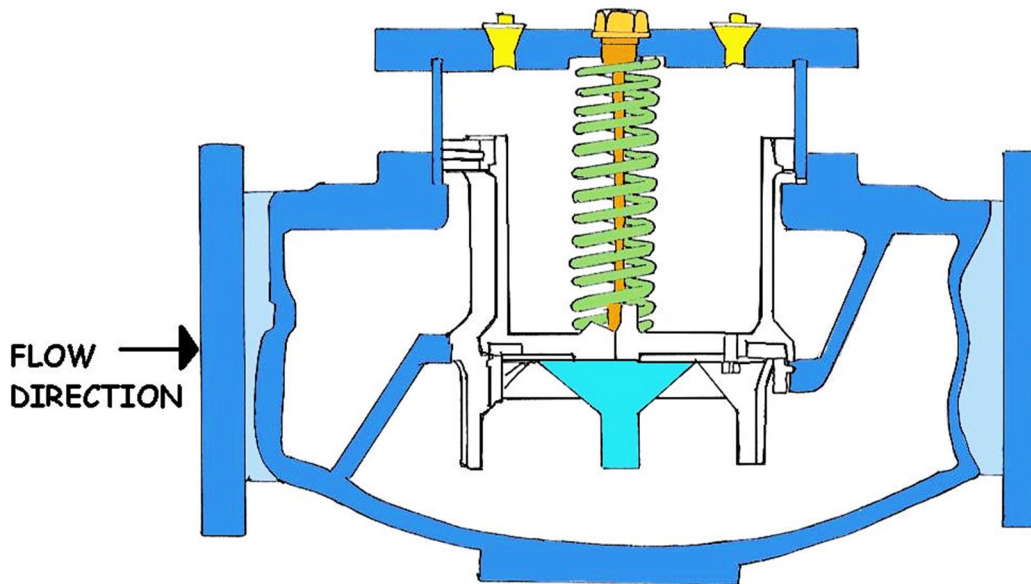

**FLANGED GLOBE STYLE PRESSURE REDUCING VALVE**

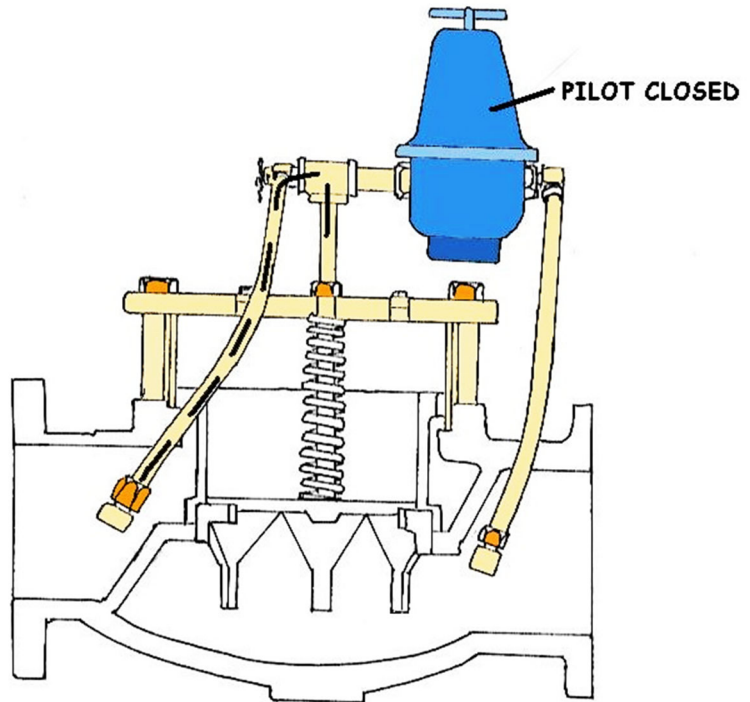

**REDUCED PRESSURE VALVE OPERATION  
(VALVE CLOSED ABOVE - VALVE OPENED BELOW)**

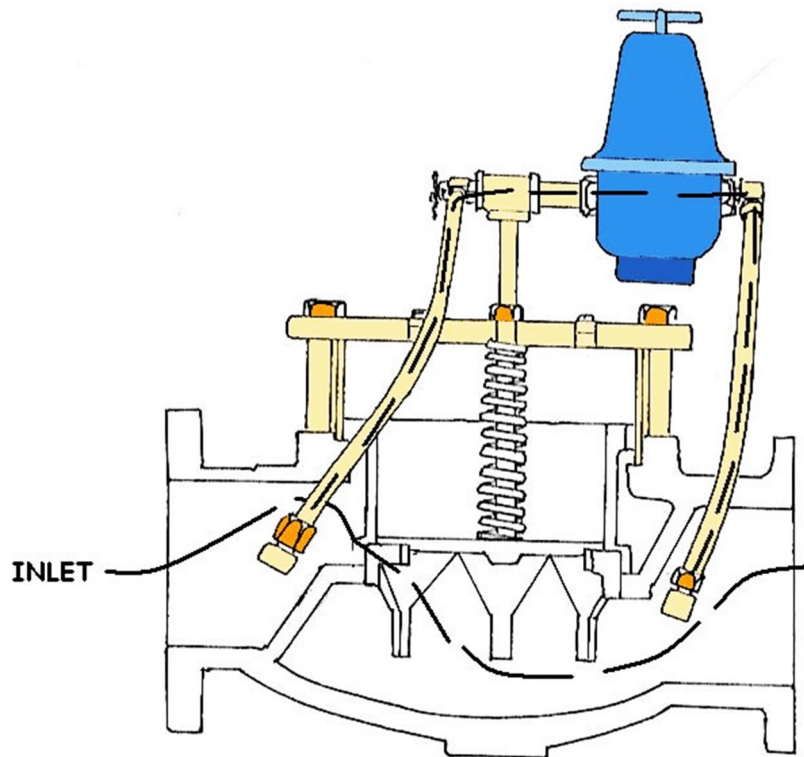

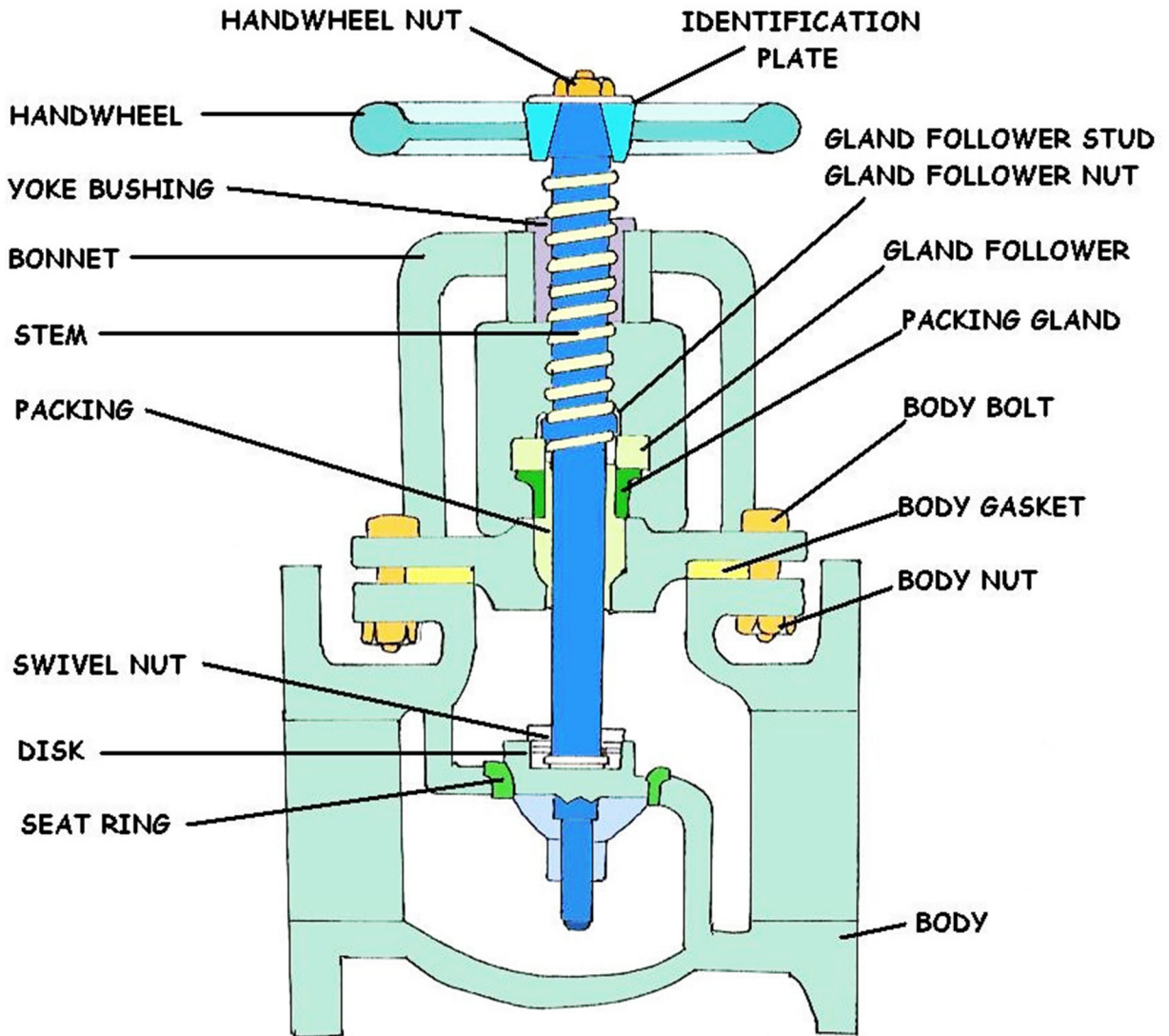

**Friction Loss**

Water will still be distributed through the system if a single section fails. The damaged section can be isolated and the remainder of the system will still carry water.

Water supplied to fire hydrants will feed from multiple directions. Thus during periods of peak fire flow demand, there will be less impact from "friction loss" in water mains as the velocity within any given section of main will be less since several mains will be sharing the supply.

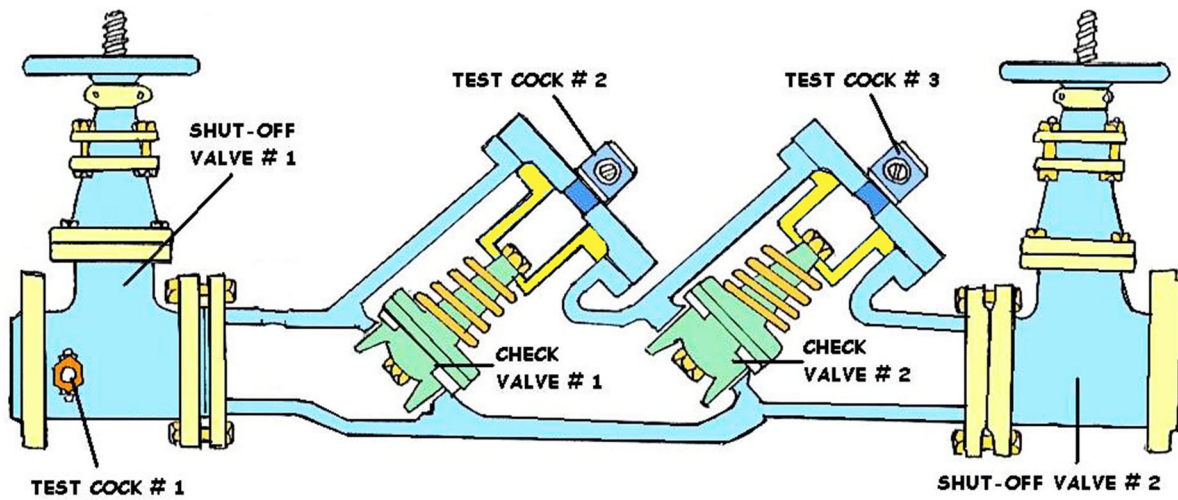

**DOUBLE-CHECK BACKFLOW ASSEMBLY**

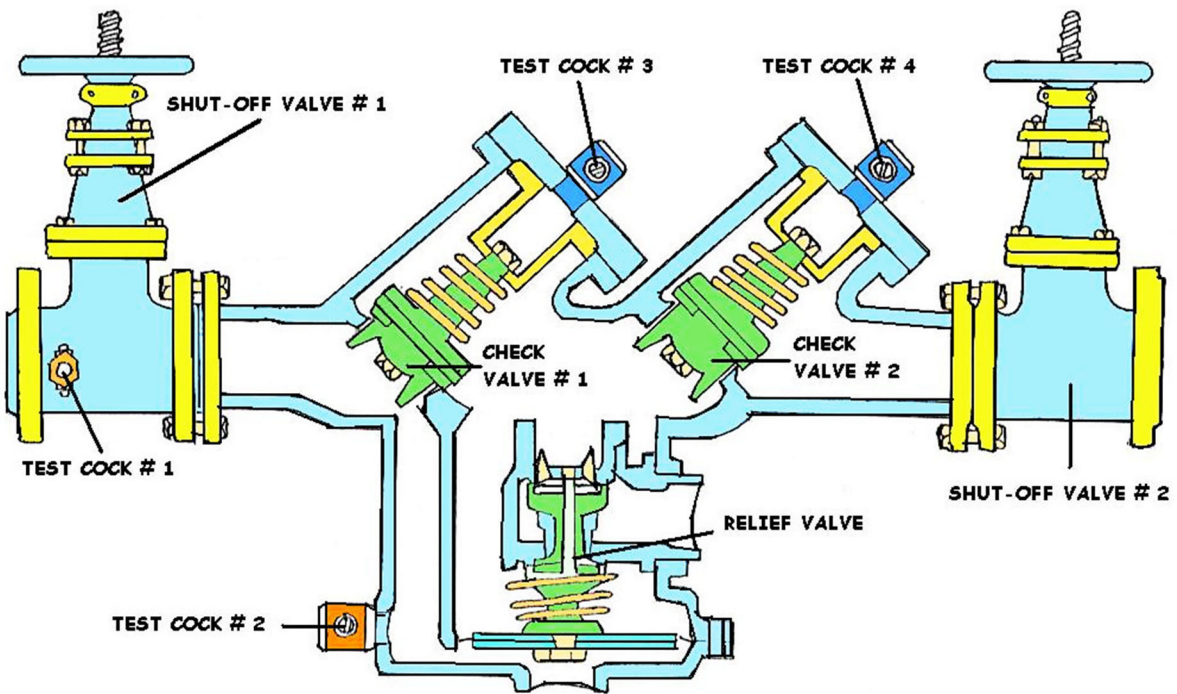

**REDUCED PRESSURE PRINCIPLE BACKFLOW ASSEMBLY**

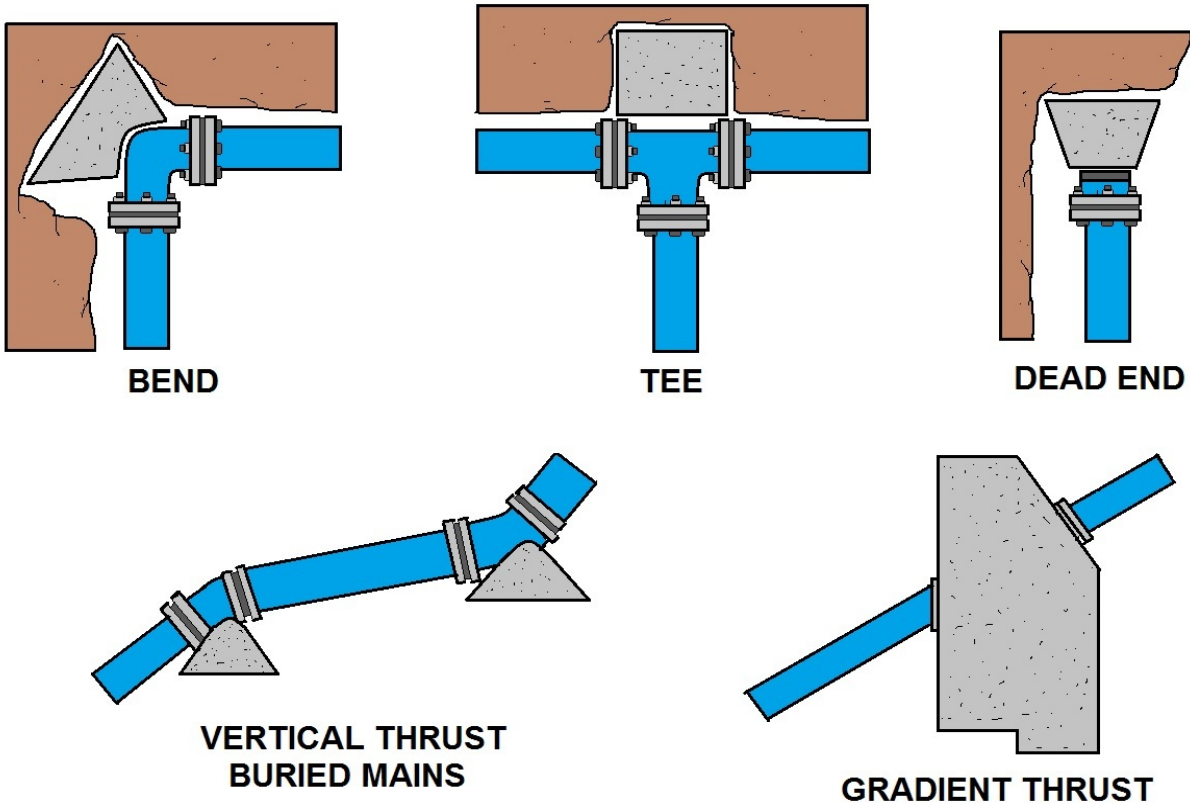

**PROPER THRUST BLOCKING PROCEDURES**

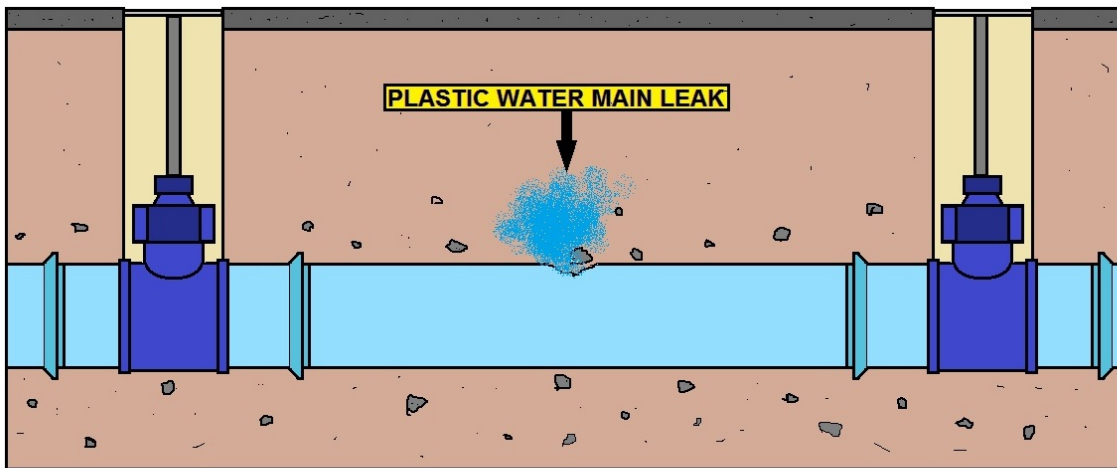

**PLASTIC WATER MAIN LEAK**

**MOST PLASTIC MAIN WATER LEAKS ARE CAUSED BY ROCKS OR SHARP OBJECTS SCRAPING AGAINST PIPING / LEAKS ARE GENERALLY HORIZONTAL LEAKS**

## Pressure Reducing Valves - *Rotary Valve*

### Pressure Relief Valve

Pressure relief valves are used to release excess pressure that may develop as a result of a sudden change in the velocity of the water flowing in the pipe.

PRVs assist in a variety of functions, from keeping system pressures safely below a desired upper limit to maintaining a set pressure in part of a circuit. Types include relief, reducing, sequence, counterbalance, and unloading. All of these are normally closed valves, except for reducing valves, which are normally open. For most of these valves, a restriction is necessary to produce the required pressure control. One exception is the externally piloted unloading valve, which depends on an external signal for its actuation.

The most practical components for maintaining secondary, lower pressure in a hydraulic system are pressure-reducing valves. Pressure-reducing valves are normally open, 2-way valves that close when subjected to sufficient downstream pressure. There are two types: direct acting and pilot operated.

**Direct acting** - A pressure-reducing valve limits the maximum pressure available in the secondary circuit regardless of pressure changes in the main circuit, as long as the work load generates no back flow into the reducing valve port, in which case the valve will close.

The pressure-sensing signal comes from the downstream side (secondary circuit). This valve, in effect, operates in reverse fashion from a relief valve (which senses pressure from the inlet and is normally closed). As pressure rises in the secondary circuit, hydraulic force acts on area A of the valve, closing it partly. Spring force opposes the hydraulic force, so that only enough oil flows past the valve to supply the secondary circuit at the desired pressure. The spring setting is adjustable.

When outlet pressure reaches that of the valve setting, the valve closes, except for a small quantity of oil that bleeds from the low-pressure side of the valve, usually through an orifice in the spool, through the spring chamber, to the reservoir. Should the valve close fully, leakage past the spool could cause pressure build-up in the secondary circuit. To avoid this, a bleed passage to the reservoir keeps it slightly open, preventing a rise in downstream pressure above the valve setting. The drain passage returns leakage flow to reservoir. (Valves with built-in relieving capability also are available to eliminate the need for this orifice.)

**Constant and fixed pressure reduction** - Constant-pressure-reducing valves supply a preset pressure, regardless of main circuit pressure, as long as pressure in the main circuit is higher than that in the secondary. These valves balance secondary-circuit pressure against the force exerted by an adjustable spring which tries to open the valve. When pressure in the secondary circuit drops, spring force opens the valve enough to increase pressure and keep a constant reduced pressure in the secondary circuit. Fixed pressure reducing valves supply a fixed amount of pressure reduction regardless of the pressure in the main circuit. For instance, assume a valve is set to provide reduction of 250 psi. If main system pressure is 2,750 psi, reduced pressure will be 2,500 psi; if main pressure is 2,000 psi, reduced pressure will be 1,750 psi.

This valve operates by balancing the force exerted by the pressure in the main circuit against the sum of the forces exerted by secondary circuit pressure and the spring. Because the pressurized areas on both sides of the poppet are equal, the fixed reduction is that exerted by the spring.

**How do Pressure Relief Valves Operate?**

Most pressure relief valves consist of a main valve and pilot control system. The basic main Cla-Val valve is called a Hytrol Valve.

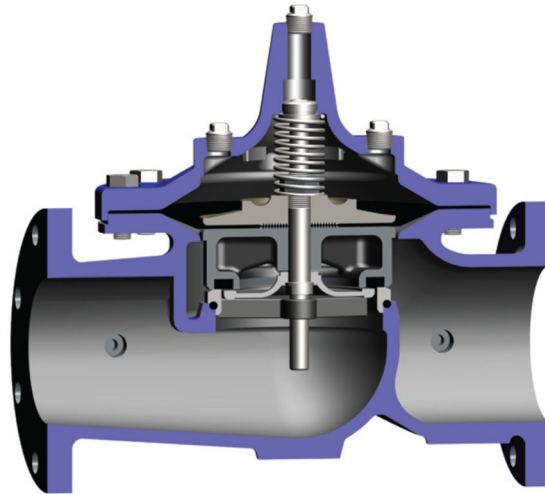

When no pressure is in the valve, the spring and the weight of the diaphragm assembly hold the valve closed.

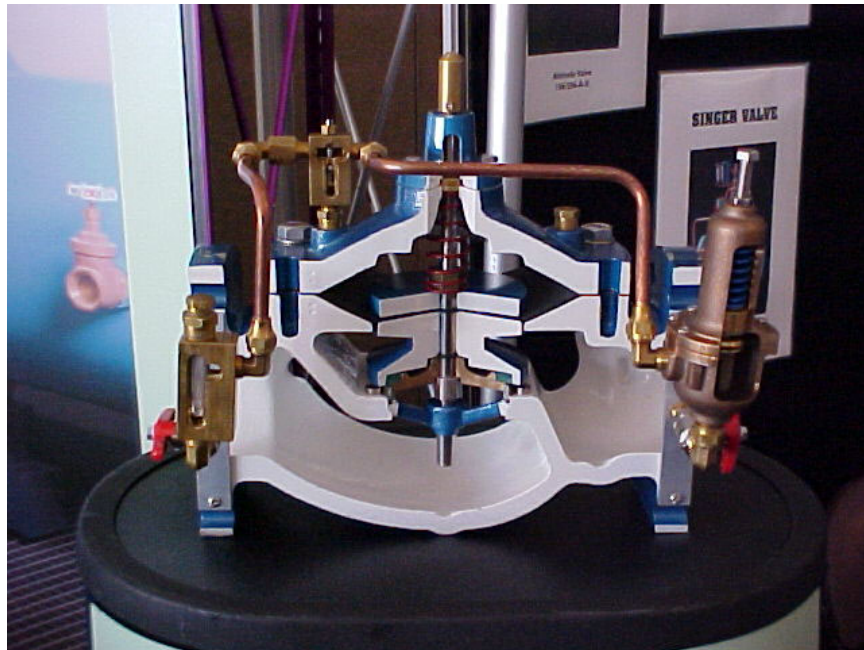



Often a small box can be connected to an existing pilot PRV valve to control the main Pressure Reducing Valve on the pipe network. This single box contains both the control electronics and an integral data logger to save the cost and space of having both a controller and a separate data logger. There are basically two types of PRV controllers, either time-based (to reduce the pipe pressure at low demand times, e.g. at night) or flow modulated controllers which can realize leakage savings throughout the day and night (by adjusting the pressure according to the demand to prevent excessive pressure at any time of the day or night).

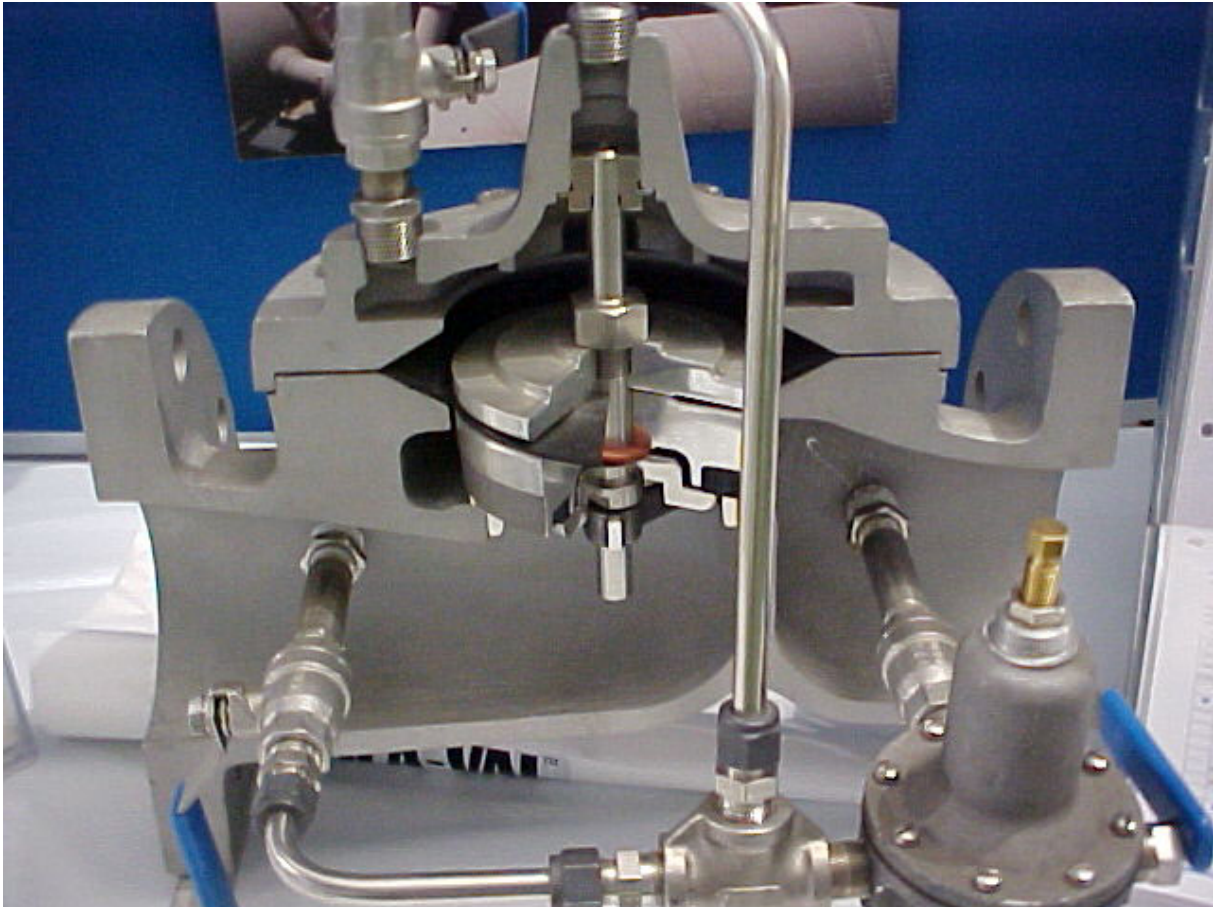

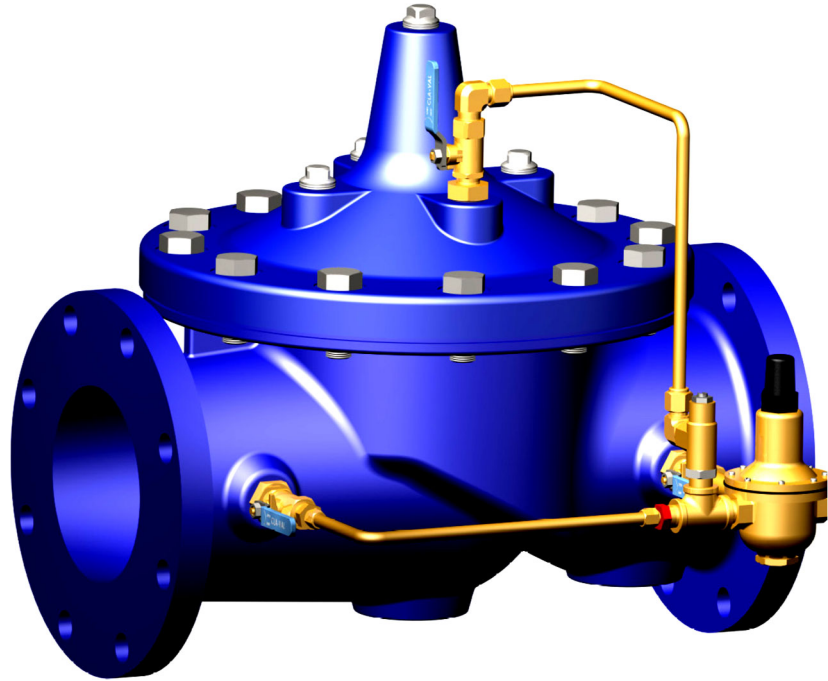

**Pressure Reducing Valve Cla-Val 90 Series**

- Holds downstream pressure to a pre-determined limit.
- Optional check feature.
- Fully supported frictionless diaphragm.

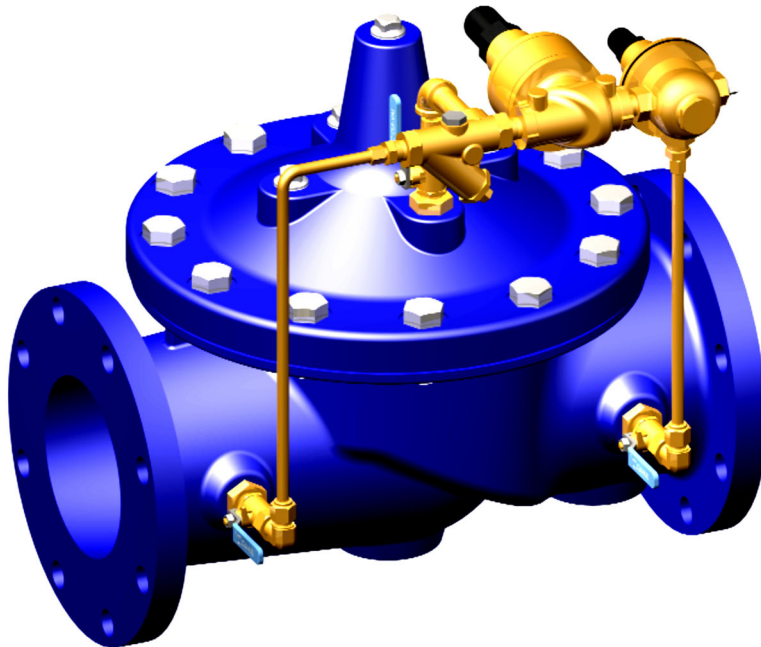

**Pressure Reducing/Pressure Sustaining Control Valve Cla-Val 92 Series**

- Maintains downstream pressure regardless of fluctuating demand and sustains upstream pressure to a pre-set minimum.
- Optional check feature.

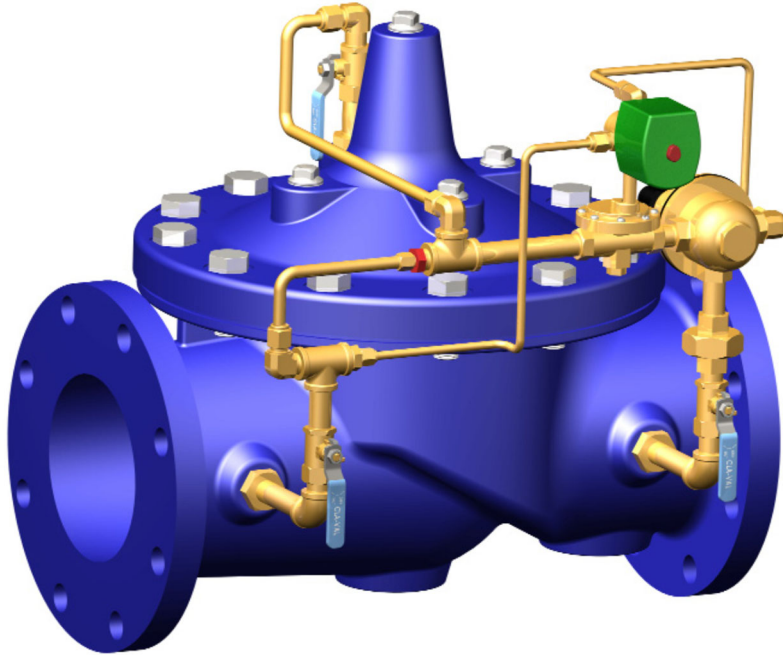

**Pressure Reducing & Solenoid Shut-Off Valve Cla-Val 93 Series**

- Ideal for reducing high transmission line pressures to lower distribution system pressures.
- Solenoid can be remotely activated.



**Pressure Reducing & Surge Control Valve Cla-Val 94 Series**

- Integral surge pilot opens to prevent rapid pressure increases.
- Optional check feature.

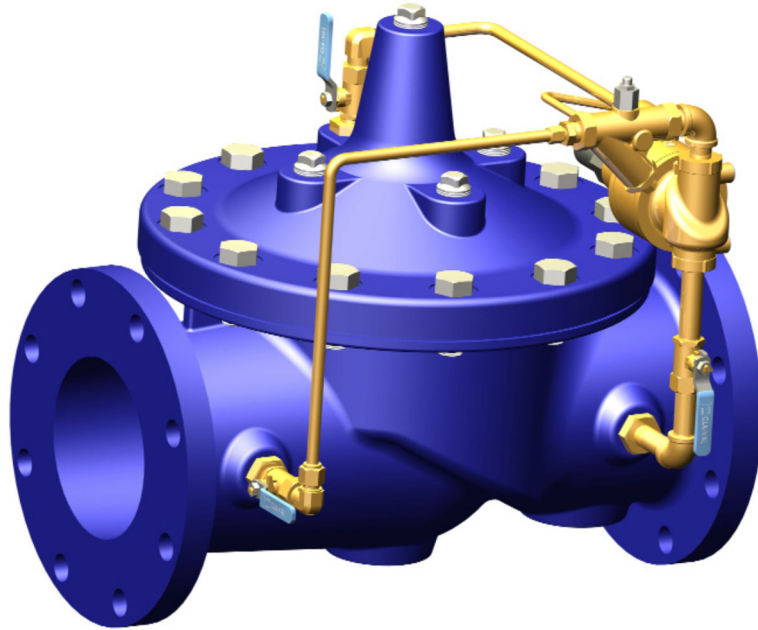

**Pressure Relief/Pressure Sustaining Valve Cla-Val 50 Series**

- Completely automatic operation.
- Accurate pressure control.
- Fast opening maintains line pressure.
- Slow closing prevents surges.
- Optional check feature.

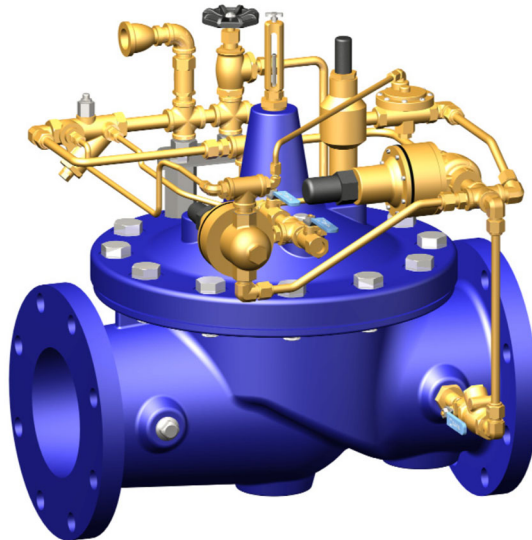

**Surge Anticipator Valve Cla-Val 52 Series**

- Protects pumping equipment and pipelines from damage caused by rapid flow velocity changes.
- Opens on initial low pressure wave.
- Closes slowly to prevent subsequent surges.



**Float Valve Cla-Val 124 Series**

- Accurate and repeatable level control in tanks to pre-set high and low points
- Reliable drip-tight shut-off.
- On-Off non-modulating action.
- Use Model 428-01 for modulating service.

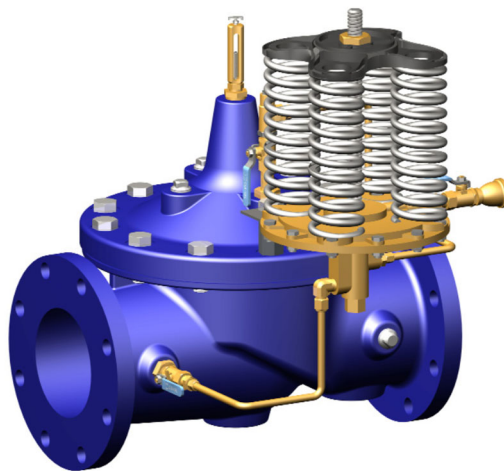

**Altitude Control Valve Cla-Val 210 Series**

- Provides accurate and repeatable tank level control.
- Optional check valve feature.
- Delayed opening option available.
- One-way and two-way flow pilot systems available.

## SERIES 2000 Features

1. Full-ported for high capacity
2. Stainless trim - Standard
3. Stainless steel vee-ports for precise low flow control
4. 1- 1/2" through 3" - Screwed NPT connections  
2" through 12"- 125# Flanged connections
5. Globe or angle body, both use identical internal parts
6. Only one moving part
7. No rubber diaphragms to fatigue, rot, rupture or fail.
8. Drop-tight closure
9. Streamlined body for low inherent headloss
10. 100% tested for reliability
11. Easily maintained in the line
12. Many options available

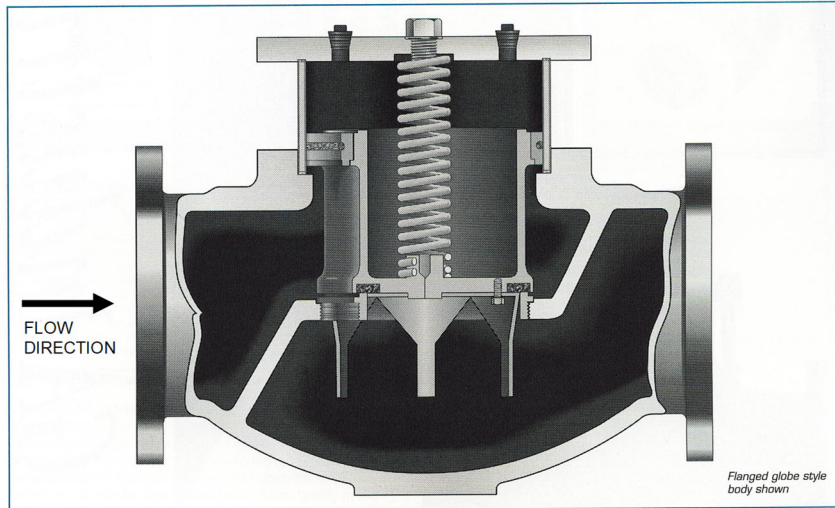

## SERIES 2000 Features

1. Full-ported for high capacity
2. Stainless trim - Standard
3. Stainless steel vee-ports for precise low flow control
4. 1- 1/2" through 3" - Screwed NPT connections  
2" through 12"- 125# Flanged connections
5. Globe or angle body, both use identical internal parts
6. Only one moving part
7. No rubber diaphragms to fatigue, rot, rupture or fail.
8. Drop-tight closure
9. Streamlined body for low inherent headloss
10. 100% tested for reliability
11. Easily maintained in the line
12. Many options available

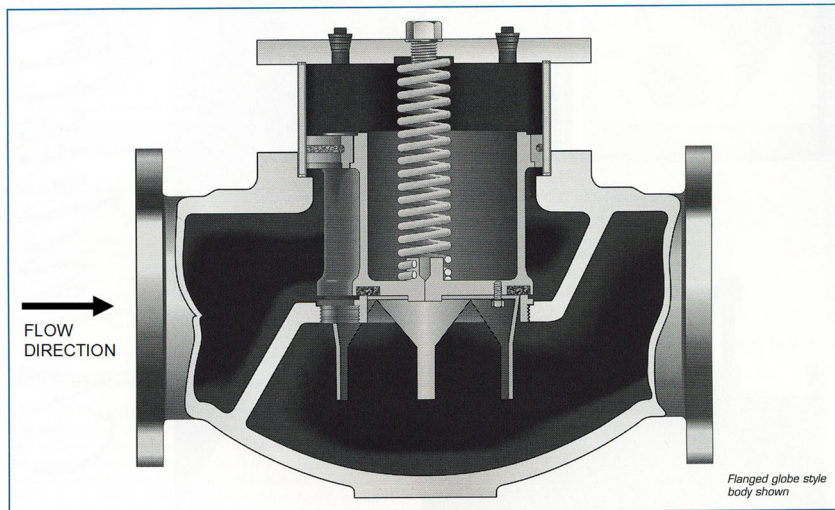

# Pressure Reducing Valve Operation

SERIES 2000 pressure reducing valves will throttle to maintain a steady downstream pressure as set by the pilot spring adjustment. The valve will close drip-tight when the downstream pressure exceeds the pilot setting.

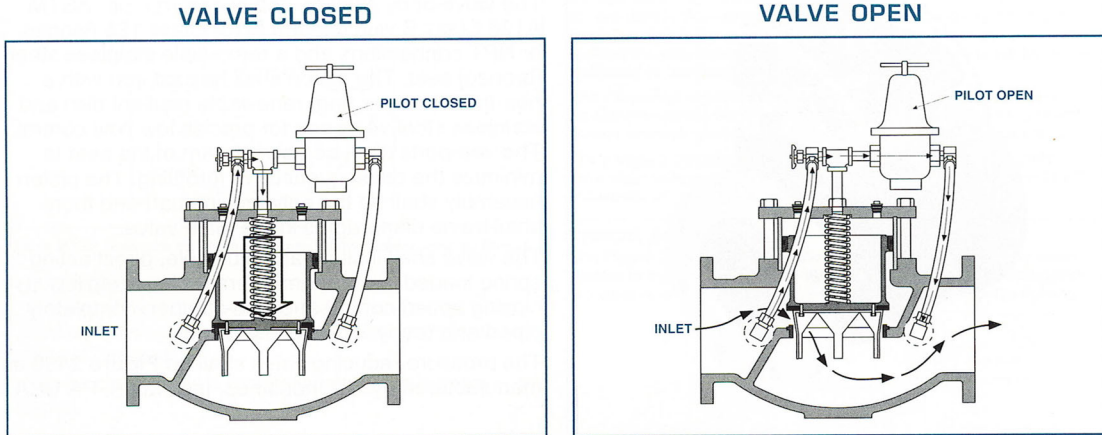

Figure 1. Valve closed when downstream pressure exceeds pilot setting

The valve is installed with flow "over the seat." Inlet pressure is conveyed to the top of the piston by means of a small pilot line and a closing speed control needle valve. Downstream pressure is applied to the underside of the pilot valve's diaphragm and is opposed by the pilot's adjusting spring. The pilot closes when the downstream pressure exceeds the adjusting spring set point, allowing inlet pressure to build on the upper surface of the piston and hold the main valve closed.

Figure 2. Valve throttles to satisfy demand at setting of pilot

Should downstream pressure fall to the setting of the pilot spring, the pilot opens and allows flow from above the piston to the downstream side of the valve at a faster rate than can be applied through the inlet needle valve. This reduces the pressure on the upper surface of the piston so that inlet pressure, which is constantly applied to the underside of the piston, lifts the piston and opens the main valve. The pilot "throttles" the main valve, allowing sufficient flow to match demand in order to maintain the downstream pressure as determined by the pilot setting.

PILOT PARTS	
W1	PILOT BODY
W2	RENEWABLE SEAT
W3	BOTTOM CAP SEAL
W4	SEAT HOLDER
W5	SEAT RING
W6	YOKE
W7	CHAMBER SCREWS
W8	DIAPHRAGM NUT
W9	DIAPHRAGM
W10	DIAPHRAGM WASHER
W11	SPRING CHAMBER
W12	SPRING
W13	SPRING WASHER
W14	STEM LOCKNUT
W15	ADJUSTING SCREW
W16	SEAT SCREW
W17	BOTTOM CAP
W18	SEAT GASKET

REV. B: WAS 1/2" NPT SIZE ONLY; MJB; 07-20-2001.  
REV. A: REDRAWN, MJB; 12-18-97.

**GA INDUSTRIES, INC.**

1/2 - 2" NPT PRESSURE REDUCING PILOT VALVE

STANDARD TOLERANCES (UNLESS OTHERWISE SPECIFIED)	REFERENCES	SCALE	DRAWN BY
FRACTIONAL DIMENSIONS: .0005, .001, .002, .003, .005, .010, .015, .030, .045, .060, .075, .090, .120, .150, .180, .225, .280, .350, .450, .560, .700, .875, 1.125, 1.500, 2.000, 2.500, 3.150, 4.000, 5.000, 6.300, 8.000, 10.000, 12.500, 16.000, 20.000, 25.000, 31.500, 40.000, 50.000, 63.000, 80.000, 100.000	SERIAL NO.	NONE	RLD
DECIMAL DIMENSIONS: .0005, .001, .002, .003, .005, .010, .015, .030, .045, .060, .075, .090, .120, .150, .180, .225, .280, .350, .450, .560, .700, .875, 1.125, 1.500, 2.000, 2.500, 3.150, 4.000, 5.000, 6.300, 8.000, 10.000, 12.500, 16.000, 20.000, 25.000, 31.500, 40.000, 50.000, 63.000, 80.000, 100.000	DATE	EFFECTIVE DATE	APPR. BY
ANGLE: 1/4°, 1/2°, 3/4°, 1°, 1.5°, 2°, 3°, 4.5°, 6°, 9°, 12°, 15°, 30°, 45°, 60°, 75°, 90°, 105°, 120°, 135°, 150°, 165°, 180°	43223	10-2-78	
	PART NUMBER	SIZE	DRAWING NO.
	D1		D-1035
			REV. B

F:\CA-VALVE\GA-SHOW\D-1035-B.PRT

Related in Plant Valves

# Plant Pump Check Valves

## COMMONLY USED PUMP CHECK VALVES

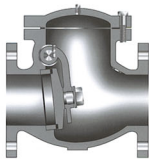

Plain Swing  
check valve



Lever and Spring  
Swing check valve



Lever and Weight  
Swing check valve

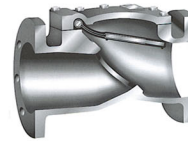

Rubber Flapper  
Swing check valve

**Surge Relief valves are not usually employed due to short pipe runs in the plant.**

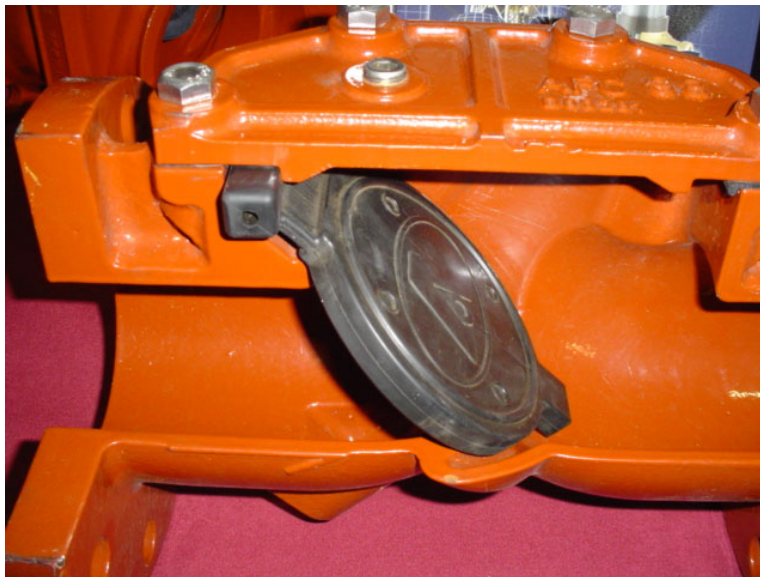

A beautiful swing check valve. Swing checks need to be maintained. I hate finding a swing check that is either buried and/or forgotten, rusted in place or, my favorite, the check was removed. Yes, folks, you too will find these three conditions. Send me a photograph if you do. I love stories and photographs from the field.



## Wastewater Section

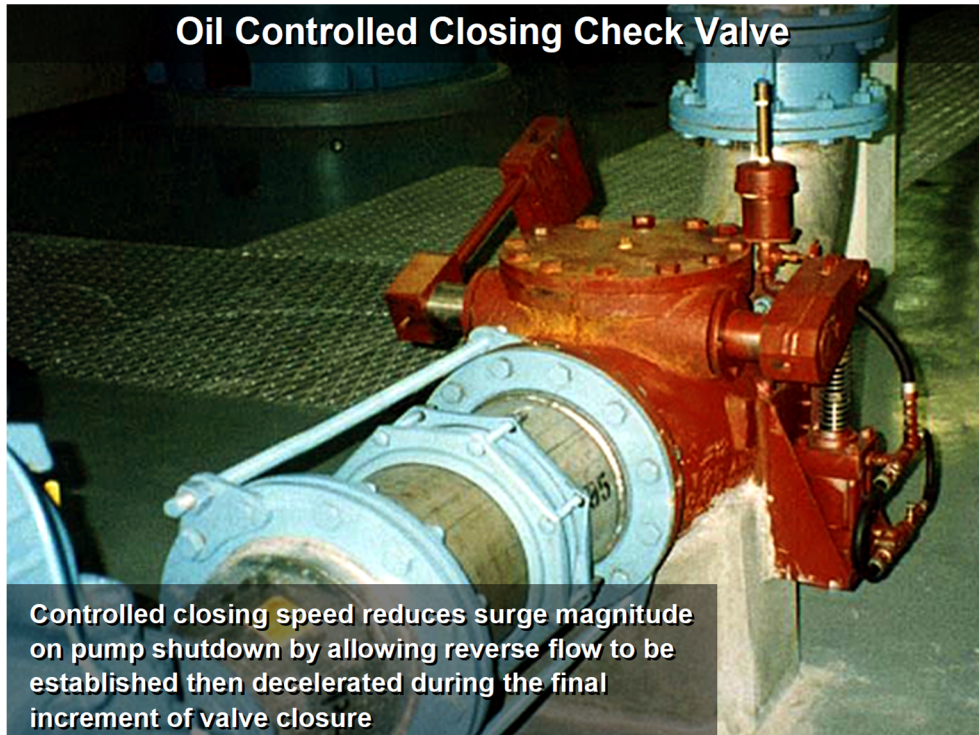

Wastewater valves are widely used in different industries like dairy, food, pharmaceutical, medical and chemical industries to name a few.

These sanitary valves perform various features like easy cleaning, crevice free, and polish contact surfaces.

Types among these sanitary valves can be seen in the form of sanitary ball valves, sanitary sewer valves, sanitary butterfly valves, sanitary check valves, sanitary globe valves and many other such sanitary valves.

Variations among these sanitary valves can also be seen in their working pressure and operating temperature. These sanitary valves carry gas and liquid media or liquid with suspended solids. Metals like brass, bronze, copper, cast iron, ductile iron, stainless steel, and steel are used in the manufacture of these sanitary valves to ensure that they have a longer life.



# Lift Station

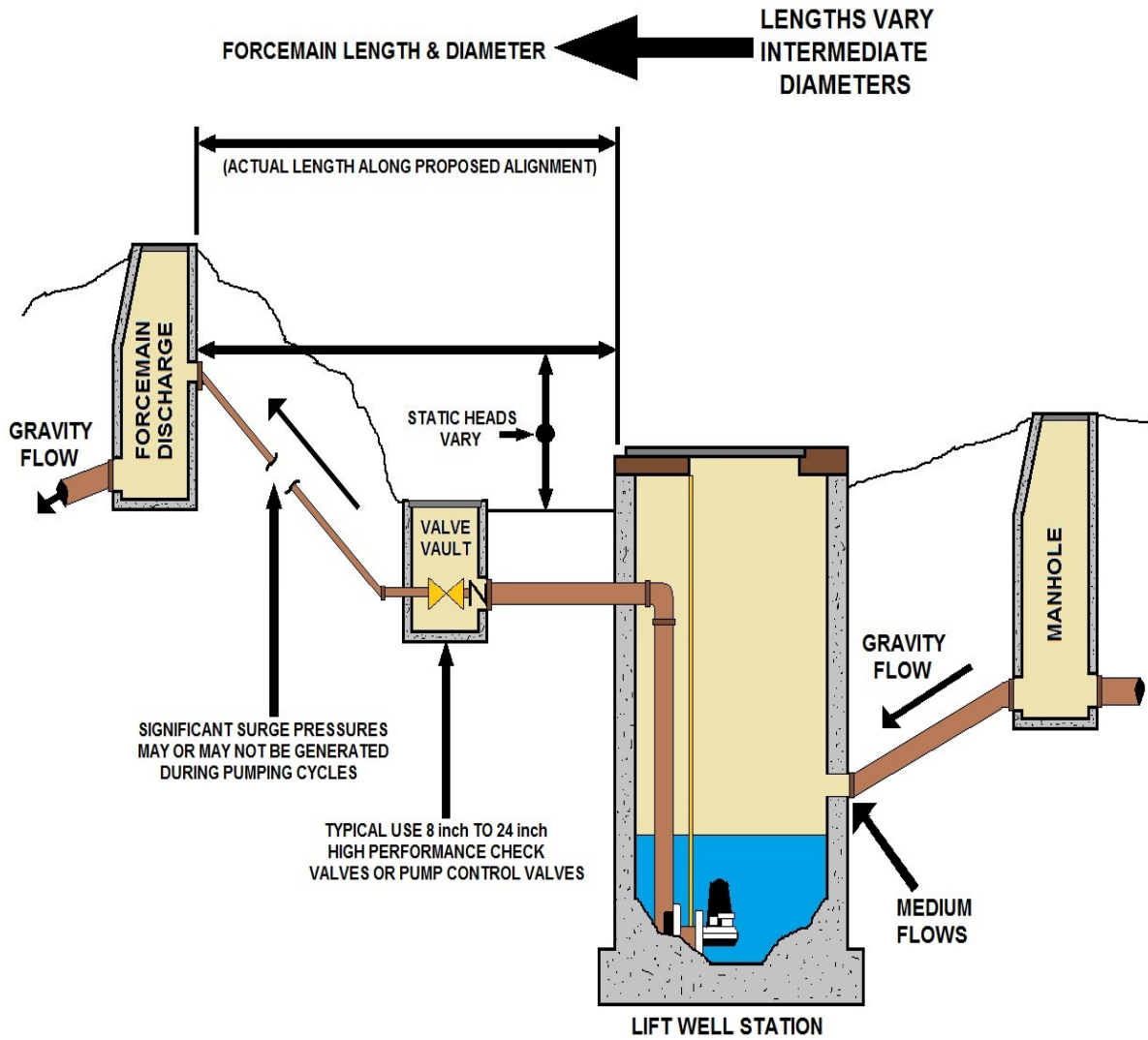

## MEDIUM SEWAGE LIFT STATION TYPICAL CHARACTERISTICS

## Valve Exercising Section

Valve exercising should be done once per year (especially main line valves) to detect malfunctioning valves and to prevent valves from becoming inoperable due to freezing or build-up of rust or corrosion. A valve inspection should include drawing valve location maps to show distances (ties) to the valves from specific reference points (telephone poles, stonelines, etc.).

**Hydrants** are designed to allow water from the distribution system to be used for fire-fighting purposes.



Bottom of a dry barrel fire hydrant--there is a drainage hole on the back of this hydrant, sometimes referred to as a "weep hole". Below is an "Airport Runway" type of hydrant. These are difficult to find.

## Here are Common Valve Operation Problems

**Valve stem is improperly lubricated or damaged**--I always liked to find a bent brass stem. Just a small bend will make most valves difficult to operate. This also applies to misplaced valve boxes. It is best to disassemble the valve and inspect the stem. Acceptable deviation from theoretical centerline created by joining center points of the ends of the stem is 0.005"/ft of stem. Inspect the threads for any visible signs of damage. Small grooves less than 0.005" can be polished with an Emory cloth. Contact specialized services or an outside contractor if run-out is unacceptable or large grooves are discovered on the surface of the stem.

**Valve packing compression is too tight**--Verify the packing bolt torque and adjust if necessary.

**Foreign debris is trapped on threads and/or in the packing area**--This is a common problem when valves are installed outdoors in sandy areas and in areas not cleaned before operating. Always inspect threads and packing area for particle obstructions; even seemingly small amounts of sand trapped on the drive can completely stop large valves from cycling. The valve may stop abruptly when a cycle is attempted. With the line pressure removed from the valve, disconnect the actuator, gear operator or handwheel and inspect the drive nut, stem, bearings and yoke bushing.

Contaminated parts should be cleaned with a lint-free cloth using alcohol, varsol or the equivalent. All parts should be re-lubricated before re-assembly. If the valves are installed outdoors in a sandy area, it may be desirable to cover the valves with jackets.

**Valve components are faulty or damaged**-- contact the supply house or warehouse. Most valve salesmen will try to keep your business and do whatever is possible to do so. In the last ten years only one manufacturer did not replace a faulty valve. It is one of the largest makers of water valves and blew me off. It was clearly a bad valve to begin with. Sad part of this story is that the large American valve companies have to deal with aggressive Chinese valve companies that will make things right to keep your business. Most of these valves that I have seen are great for most water and wastewater work. They have nice finishes and even come in stainless steel--Probably made from recycled American cars. I just hate to switch over to anything other than American but I guess we are living in a Global market.

**The handwheel is too small**--Increasing the size of the handwheel will reduce the amount of torque required to operate the valve. If a larger handwheel is installed, the person operating the valve must be careful not to over-torque the valve when closing it. Most Valve operators will have a set of special keys for the operation of most valves but a small wheel can present problems as well as no hand wheel.

Dr. Rusty's commentary, Over the years and at most systems, it seems that the institutional knowledge that most of the old timers have is priceless and under appreciated by most management. The reason I say this is most experienced Valvemen or Valve Operators know their system better than any map or GIS system. Don't throw these people under the bus!

## Slam, Surge and Water Hammer

When a valve is closed *instantaneously* there is a corresponding *instantaneous* pressure rise, causing a water hammer.

Water hammer (or, more generally, fluid hammer) is a pressure surge or wave caused by the kinetic energy of a fluid in motion when it is forced to stop or change direction suddenly. It depends on the fluid compressibility where there are sudden changes in pressure. For example, if a valve is closed suddenly at the end of a pipeline system, a water hammer wave propagates in the pipe. Moving water in a pipe has kinetic energy proportional to the mass of the water in a given volume times the square of the velocity of the water.

### The Effects of Water Hammer And Pulsations

Quick closing valves, positive displacement pumps, and vertical pipe runs can create damaging pressure spikes, leading to blown diaphragms, seals and gaskets, and also destroyed meters and gauges.

Liquid, for all practical purposes, is not compressible: any energy that is applied to it is instantly transmitted. This energy becomes dynamic in nature when a force such as a quick closing valve or a pump applies velocity to the fluid.

### Surge (Water Hammer)

Surge (or water hammer, as it is commonly known) is the result of a sudden change in liquid velocity. Water hammer usually occurs when a transfer system is quickly started, stopped or is forced to make a rapid change in direction. Any of these events can lead to catastrophic system component failure. Without question, the primary cause of water hammer in process applications is the quick closing valve, whether manual or automatic. A valve closing in 1.5 sec. or less depending upon valve size and system conditions causes an abrupt stoppage of flow. The pressure spike (acoustic wave) created at rapid valve closure can be high as five(5) times the system working pressure.

For this reason, most pipe-sizing charts recommend keeping the flow velocity at or below 5 ft/s (1.5 m/s). If the pipe is suddenly closed at the outlet (downstream), the mass of water before the closure is still moving forward with some velocity, building up a high pressure and shock waves. In domestic plumbing this is experienced as a loud bang resembling a hammering noise. Water hammer can cause pipelines to break or even explode if the pressure is high enough. Air traps or stand pipes (open at the top) are sometimes added as dampers to water systems to provide a cushion to absorb the force of moving water in order to prevent damage to the system. (At some hydroelectric generating stations, what appears to be a water tower is actually one of these devices.) The water hammer principle can be used to create a simple water pump called a hydraulic ram.

On the other hand, when a valve in a pipe is closed, the water downstream of the valve will attempt to continue flowing, creating a vacuum that may cause the pipe to collapse or implode. This problem can be particularly acute if the pipe is on a downhill slope. To prevent this, air and vacuum relief valves, or air vents, are installed just downstream of the valve to allow air to enter the line and prevent this vacuum from occurring.

Unrestricted, this pressure spike or wave will rapidly accelerate to the speed of sound in liquid, which can exceed 4000 ft/sec. It is possible to estimate the pressure increase by the following formula.

**Water Hammer Formula:  $P = (0.070) (V) (L) / t + P1$**

Where P = Increase in pressure  
P1 = Inlet Pressure  
V = Flow velocity in ft/sec  
t = Time in sec.(Valve closing time)  
L = Upstream Pipe Length in feet

Here's an example of pressure hammer when closing an EASMT solenoid valve, with a 50 ft long upstream pipe connection:

L = 50 ft  
V = 5.0 ft / sec( recommended velocity for PVC piping design)  
t = 40 ms(solenoid valve closing time is approx. 40-50 ms)  
P1 = 50 psi inlet pressure

therefore,  $P = 0.07 \times 5 \times 50 / 0.040 + P1$   
or  $P = 437.5 \text{ psi} + P1$

Total Pressure =  $437.5 + 50 = 487.5 \text{ psi}$

### **Pulsation**

Pulsation generally occurs when a liquid's motive force is generated by reciprocating or peristaltic positive displacement pumps. It is most commonly caused by the acceleration and deceleration of the pumped fluid. This uncontrolled energy appears as pressure spikes. Vibration is the visible example of pulsation and is the culprit that usually leads the way to component failure.

Unlike centrifugal pumps(which produce normally non-damaging high-frequency but low-amplitude pulses), the amplitude is the problem because it's the pressure spike. The peak, instantaneous pressure required to accelerate the liquid in the pipe line can be greater than ten (10) times the steady state flow pressure produced by a centrifugal pump.

Damage to seals gauges, diaphragms, valves and joints in piping result from the pressure spikes created by the pulsating flow.

### **Remedy**

Suggest that you install a pulsation dampener or surge tank. Dampeners provide the most cost efficient and effective choice to prevent the damaging effects of pulsation. A surge suppressor is in design essentially the same as pulsation dampener.

The difference primarily lies in sizing and pressurizing. The most current pulsation dampener design is the hydro-pneumatic dampener, consisting of a pressure vessel containing a compressed gas, generally air or Nitrogen separated from the process liquid by a bladder or diaphragm.

## Types of Pipes Used in the Water Distribution Field

Several types of pipe are used in water distribution systems, but only the most common types used by plumbers and operators will be discussed. These piping materials include copper, plastic, galvanized steel, and cast iron. Some of the main characteristics of pipes made from these materials are presented below.

### Plastic Pipe (PVC)

Plastic pipe has seen extensive use in current construction. Available in different lengths and sizes, it is lighter than steel or copper and requires no special tools to install. Plastic pipe has several advantages over metal pipe: it is flexible; it has superior resistance to rupture from freezing; it has complete resistance to corrosion; and, in addition, it can be installed aboveground or below ground.

One of the most versatile plastic and polyvinyl resin pipes is the polyvinyl chloride (PVC). PVC pipes are made of tough, strong thermoplastic material that has an excellent combination of physical and chemical properties. Its chemical resistance and design strength make it an excellent material for application in various mechanical systems.

Sometimes polyvinyl chloride is further chlorinated to obtain a stiffer design, a higher level of impact resistance, and a greater resistance to extremes of temperature. A CPVC pipe (a chlorinated blend of PVC) can be used not only in cold-water systems, but also in hot-water systems with temperatures up to 210°F. Economy and ease of installation make plastic pipe popular for use in either water distribution and supply systems or sewer drainage systems.



Various types and sizes of coupons or tap cut-outs. You will want to date and collect these cut-outs to determine the condition of the pipe or measure the corrosion.

**Plastic Pipe (PVC)**

This is currently the most common type of pipe used in distribution systems. It is available in diameters of 1/2" and larger, and in lengths of 10', 20', and 40'. A main advantage is its light weight, allowing for easy installation. A disadvantage is its inability to withstand shock loads. Since it is non-metallic, a tracer wire must be installed with the PVC water main so that it can be located after burial.

The National Sanitation Foundation (NSF) currently lists most brands of PVC pipe as being acceptable for potable water use. This information should be stamped on the outside of the pipe, along with working pressure and temperature, diameter and pipe manufacturer.

PVC pipe will have the highest C Factor of all the above pipes. The higher the C factor the smoother the pipe.

**Cast Iron (CIP)**

This is another type of piping material that has been in use for a long time. It is found in diameters from 3" to 48". Advantages of this material are its long life, durability and ability to withstand working pressures up to 350 psi. Disadvantages include the fact that it is heavy, difficult to install and does not withstand shock loading. Although it is not currently the material of choice, there is still a lot of it in the ground.

**Ductile Iron Pipe (DIP)**

This was developed to overcome the breakage problems associated with cast iron pipe. It can be purchased in 4" to 45" diameters and lengths of 18' to 20'. Its main advantage is that it is nearly indestructible by internal or external pressures. It is manufactured by injecting magnesium into molten cast iron.

It is sometimes protected from highly corrosive soils by wrapping the pipe in plastic sheeting prior to installation. This practice can greatly extend the life of this type of pipe.

**Steel Pipe**

This pipe is often used in water treatment plants and pump stations. It is available in various diameters and in 20' or 21' lengths. Its main advantage is the ability to form it into a variety of shapes.

It also exhibits good yielding and shock resistance. It has a smooth interior surface and can withstand pressures up to 250 psi. A disadvantage is that it is easily corroded by both soil and water.

To reduce corrosion problems, steel pipe is usually galvanized or dipped in coal-tar enamel and wrapped with coal-tar impregnated felt.

At present, however, coal-tar products are undergoing scrutiny from a health standpoint and it is recommended that the appropriate regulatory agencies be contacted prior to use of this material.



### **Asbestos Cement Pipe (ACP)**

This pipe is manufactured from Portland cement, long fibrous asbestos and silica. It is available in diameters from 3" to 36" and in 13' lengths. Its main advantages are its ability to withstand corrosion and its excellent hydraulic flow characteristics due to its smoothness.

A major disadvantage is that it is brittle and is easily broken during construction or by shock loading. There is some concern regarding the possible release of asbestos fibers in corrosive water and there has been much debate over the health effects of ingested asbestos. Of greater concern, however, is the danger posed by inhalation of asbestos fibers.

Asbestos is considered a hazardous material, and precautionary measures must be taken to protect water utility workers when cutting, tapping or otherwise handling this type of pipe.

### **Galvanized Pipe**

Galvanized pipe is commonly used for the water distributing pipes inside a building to supply hot and cold water to the fixtures. This type of pipe is manufactured in 21-ft lengths. It is GALVANIZED (coated with zinc) both inside and outside at the factory to resist corrosion. Pipe sizes are based on nominal INSIDE diameters. Inside diameters vary with the thickness of the pipe. Outside diameters remain constant so that pipe can be threaded for standard fittings.

### **Copper**

Copper is one of the most widely used materials for tubing. This is because it does not rust and is highly resistant to any accumulation of scale particles in the pipe. This tubing is available in three different types: K, L, and M.

K has the thickest walls, and M, the thinnest walls, with L's thickness in between the other two. The thin walls of copper tubing are soldered to copper fittings. Soldering allows all the tubing and fittings to be set in place before the joints are finished. Generally, faster installation will be the result.

Type K copper tubing is available in either rigid (hard temper) or flexible (soft temper) and is primarily used for underground service in the water distribution systems.

Soft temper tubing is available in 40- or 60-ft coils, while hard temper tubing comes in 12- and 20-ft straight lengths.

Type L copper tubing is also available in either hard or soft temper and either in coils or in straight lengths. The soft temper tubing is often used as replacement plumbing because of the tube's flexibility, which allows easier installation.

Type L copper tubing is widely used in water distribution systems.

Type M copper tubing is made in hard temper only and is available in straight lengths of 12 and 20 ft. It has a thin wall and is used for branch supplies where water pressure is low, but it is *NOT* used for mains and risers. It is also used for chilled water systems, for exposed lines in hot-water heating systems, and for drainage piping.



PVC in top photograph. ABS plastic pipe in bottom. It is strange that some States allow ABS and others do not. Like with any subject, it all depends on politics.



## Soldering Copper Tubing

These are the basics to sweating or soldering copper tubing. Copper sweating is easy to do and after this chapter or if you watch the video presentation you will be without an excuse to fix all of your leaky outside faucets.

First, we are start with proper safety equipment. This includes long-sleeved shirts, work boots, eye protection and leather gloves. Copper tubing has sharp edges and will cut you. Be careful handling the tubing. There is the chance that you will be burned also. Be careful of the torch and the pipe. Do not hand your project to another person unless they are wearing gloves. More advice, do not or try not to solder directly on top of finished cement. Sometimes, water can be in the pores of the cement. It is difficult to see, and the cement may look completely dry, but your torch will find the smallest drop of water and make the water into steam and create a small explosion. This usually will happen in the morning causing small particles of concrete to spray in to your eyes.

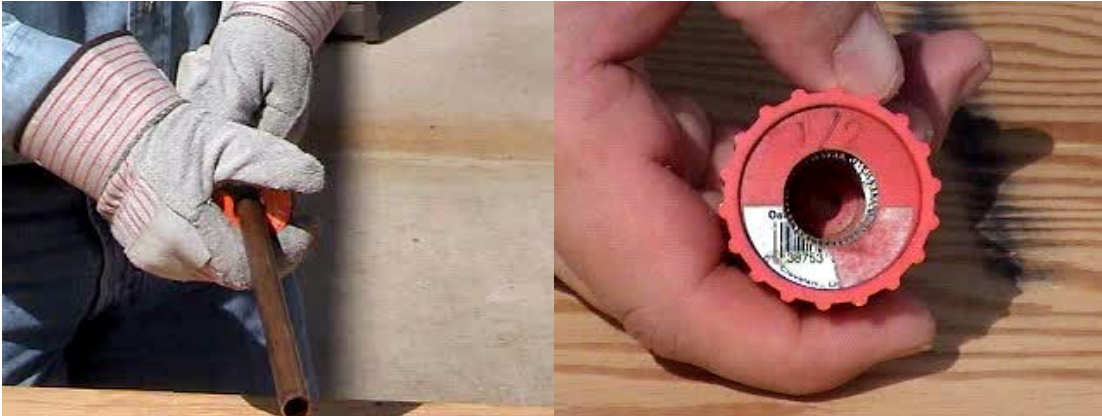

### Methods or tools for cutting the tubing.

The first one is a simple copper tubing cutter. Just simply snug the cutter on the pipe and turn the cutter. Tighten or snug the cutter a little more and turn again until the pipe has been cut in two. Simple. Do not force the pipe cutter or thread the pipe. You must be careful not to break the little cutter's wheel.

Here is a new type of copper cutter in the top left side picture. Just simply snap the tool on the pipe and twist.

Next we are going to ream the tubing of its sharp edges. This is necessary to prevent turbulence in the pipe which can create a pinhole leak. This is a common occurrence at 90s.

Now we are going to remove the oxidation from the pipe with a battery terminal type of cleaner. Just a wire brush inside a round plastic holder. You can see this in the top right hand side picture. You could also use sandpaper or steel wool to accomplish this necessary procedure. Next we are going to use flux. You need to use a little brush and apply a light coat of flux to the end of your tubing. The flux is needed so that the hot solder can be sucked into the joint and create a full seal.

Once the flux has been applied you can connect your fittings. We suggest that you twist your fittings to get the flux to be properly spread on the fitting and pipe end surfaces. They say that flux is not hazardous or corrosive, but for some reason it seems to eat holes in clothes.



Propane gas will work fine for half inch tubing, but it doesn't work well with the larger pipe sizes. Propane seems to take just a minute longer than map gas.

Place the flame nozzle just about one inch from the 90, focusing the heat right in the middle of the fitting. Take a piece of solder about twelve inches or so, and test the area. If the fitting is hot enough, it will draw the solder and equally distribute it around the joint. This should take about one second or so.

MAP gas is a hotter gas made of oxygen and acetylene. MAP gas works fast and the soldering is done quickly. Remember that your project is hot and be prepared to be burned if you are not careful.

#### **Most common mistake that you will make.**

This mistake is burning the flux out of the joint before you are able to apply solder. I call this burning the joint. If you overheat the joint and burn the flux, you will see the joint steaming and turning black, as you apply the solder, the solder just drips off the pipe. If this happens to you, cool the pipe off and re-sand, re-apply flux and do it again.

#### **Another Problem**

Another common problem with soldering is water. If you have one drop of water in the line, you will not be able to get a good seal. There are a couple of tricks to help you solder when there is water in the line. One method is plain old white bread. Just cram the water line with bread until the water has stopped.

You can proceed to solder your fitting at that time and then simply flush the line when you are finished. There are also small balls filled with oil that you can cram inside the pipe, or you can even freeze the pipe to sweat your fittings on. You can also purchase a special tool from most plumbing stores that works like a compression fitting or a boat drain plug and will stop the leak.

## Distribution Joints and Fittings

Fittings vary according to the type of piping material used. The major types commonly used in water service include elbows, tees, unions, couplings, caps, plugs, nipples, reducers, and adapters. Besides bell-and-spigot joints, cast-iron water pipes and fittings are made with either flanged, mechanical, or screwed joints. The screwed joints are used only on small-diameter pipe.

### Tapping Sleeve

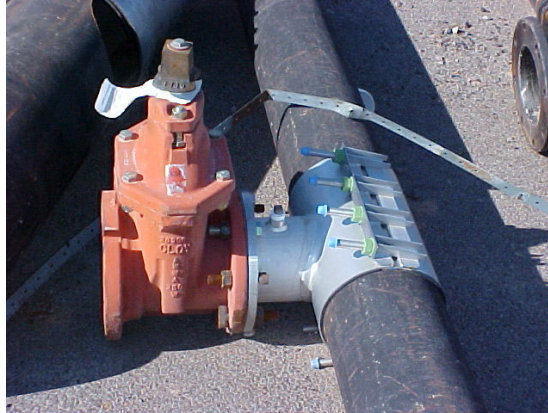

Gate Valves are used to isolate sections of water mains. Not to be used to throttle or regulate the flow.

A Globe valve should be used to regulate the flow. Be sure to chlorinate or disinfect all distribution parts such as valves.

### Caps

A pipe cap is a fitting with a female (inside) thread. It is used like a plug, except that the pipe cap screws on the male thread of a pipe or nipple.

### Couplings

The three common types of couplings are straight coupling, reducer, and eccentric reducer. The STRAIGHT COUPLING is for joining two lengths of pipe in a straight run that does not require additional fittings. A run is that portion of a pipe or fitting continuing in a straight line in the direction of flow.

A REDUCER is used to join two pipes of different sizes. The ECCENTRIC REDUCER (also called a BELL REDUCER) has two female (inside) threads of different sizes with centers so designed that when they are joined, the two pieces of pipe will not be in line with each other, but they can be installed to provide optimum drainage of the line.

### Elbows (OR ELLS) 90° AND 45°

These fittings (fig. 8-5, close to middle of figure) are used to change the direction of the pipe either 90 or 45 degrees. **REGULAR** elbows have female threads at both outlets.

STREET elbows change the direction of a pipe in a close space where it would be impossible or impractical to use an elbow and nipple. Both 45 and 90-degree street elbows are available with one female and one male threaded end. The REDUCING elbow is similar to the 90-degree elbow except that one opening is smaller than the other is.

### **Nipples**

A nipple is a short length of pipe (12 in. or less) with a male thread on each end. It is used for extension from a fitting. At times, you may use the DIELECTRIC or INSULATING TYPE of fittings. These fittings connect underground tanks or hot-water tanks. They are also used when pipes of dissimilar metals are combined. These help slow down corrosion that starts inside the pipe and works to the outside of the pipe.

Do not heat or solder dielectric fittings. You may melt the plastic coating from them.

Zinc is a coating on the outside and inside of pipes to slow corrosion. This is called "galvanization".

### **Tees**

A tee is used for connecting pipes of different diameters or for changing the direction of pipe runs. A common type of pipe tee is the STRAIGHT tee, which has a straight-through portion and a 90-degree takeoff on one side.



Notice the type of pipe connection device.  
This is known as a "Restraining Flange".

All three openings of the straight tee are of the same size. Another common type is the REDUCING tee, similar to the straight tee just described, except that one of the threaded openings is of a different size than the other.

### **Unions**

There are two types of pipe unions. The GROUND JOINT UNION consists of three pieces, and the FLANGE UNION is made in two parts. Both types are used for joining two pipes together and are designed so that they can be disconnected easily joined, the two pieces of pipe will not be in line with each other, but they can be installed to provide optimum drainage of the line.

## Water Main Installation

Installation of new or replacement pipe sections should be in accordance with good construction practices. The line must be buried a minimum of 30" below the ground surface to prevent freezing. The line must be bedded and backfilled properly insuring protection from weather and surface loadings. Also, thrust blocking (*Kickers*) at all bends, tees, and valves is essential to hold the pipe in place and prevent separation of line sections. Thrust blocking is not necessary if the pipe is welded.

Disinfection of new installations or repaired sections is required prior to placing them in service. This can be accomplished by filling the line with a 25 mg/L free chlorine solution and allowing it to stand for 24 hours. Valves and fittings used in the waterworks industry are made of cast iron, steel, brass, stainless and fiberglass.

Enough gate valves should be placed throughout the system to enable problem areas (leaks, etc.) to be isolated and repaired with minimal service disruption.

Air relief valves should be installed at highpoints in the system. Valves should be installed with valve boxes and covers.

Regardless of the type of pipe installed, certain maintenance routines should be performed on the distribution system to maintain water quality and optimal service. These programs should be scheduled and performed on a regular basis.

Flushing at blowoffs on dead end lines and at fire hydrants throughout the system should be done at least twice per year. Flushing is needed to remove stagnant water in dead ends and to remove accumulated sediment that results from turbidity, iron, manganese, etc. This should also help minimize customer complaints of water quality.



Flushing should always be done from the source to the ends of the system. Affected customers should be notified of this process in advance. To do an adequate job of flushing, the flow should reach a velocity of at least 2.5 feet per second, known as the "minimum cleansing velocity" of the system (at hydrant locations).

These tests are important to determine the adequacy of the distribution system in transmitting water, particularly during days of peak demand. Also, these tests can help determine if pipe capacity is decreasing over time due to internal corrosion or deposits.

Pressure tests should be done at various locations in the distribution system several times per year. This helps to monitor the performance of the system and alert the operator to problems such as leaks or internal deposits. It is sometimes advantageous to have certain points in the system continuously monitored to provide a constant evaluation of the system.



Installation of a new customer water service line.



## Cathodic Protection

Steel reservoirs can be subject to internal corrosion through the process of electrolysis which occurs when metallic ions are released by the steel and flow through the water, which is electrically conductive. This can be overcome by installing a “sacrificial anode,” usually composed of magnesium or zinc, in the water and connecting it to the positive side of a DC power source.

The wall of the reservoir is connected to the negative side of the power supply. This tends to reverse the flow of electrons, from the anode (hence the term sacrificial), through the water and back to the reservoir wall.

This essentially turns the steel wall of the reservoir into a cathode, or negative terminal, with respect to its surroundings, and the migration of metallic ions from the steel is retarded.



Repair crew replacing three tapping valves that blew out during a leak.

## Miscellaneous

### Sump Pump

If you have a sump pump, be sure that it is always in good operating condition so that it will be ready to function when it is needed. Oil it carefully in accordance with the manufacturer's instructions. Make it operate occasionally by tripping the lever after filling the basin particularly with water. Unless you do this every three or four months, there is danger that corrosion may cause a sticking of the shaft when operation is required.



Sump Pump

### Backwater Valve

The function of this valve is to prevent the sewer from backing up into the house during heavy rains. Most backwater valves operate automatically. A valve with a butterfly action closes against the sewer on the house side. Sometimes however, debris lodges against the seat of the valve so that it cannot close tightly. There are also manually operated valves that have a wheel handle to shut them down.

Sometimes, debris (mop strings, etc.) can accumulate or collect near the valve seat, which prevents it from closing tightly. With automatic backwater valves, removing the lid, cleaning the seat, and greasing the hinge pin on the valve gate annually will guarantee that the valve will operate as expected when it is called upon to prevent the water from coming into your basement. With the manual type of valve it is best to operate this valve every six months in order that (1) all members of the family may be familiar with the location of the valve with its function, and where the wheel for manual operation is stored; and (2) in order that the manual operation may keep the valve free from corrosion and lessen the chances for debris interfering with the valve closing.

### Flammable Vapors

Vapors from flammable liquids can explode and catch fire, causing death or severe burns. That is why it's vitally important, that you should NEVER use flammable liquids such as gasoline, adhesive solvents, lighter fluid, mineral spirits, paint thinner and kerosene around water heaters, furnaces, or any appliance with the potential for flame or sparks. Keep flammable products far away from the water heater or furnace, stored in an approved container, tightly closed and out of children's' reach. Flammable products, improperly stored or used near an open flame, give off invisible vapors that can travel the length of a house and be ignited by any of a dozen or more household sources of flame or spark. A few precautionary measures can prevent a tragedy from taking place.

## Glossary

**ABS** (Acrylonitrile butadiene styrene): Rigid black plastic pipe used only for drain lines.

**ACCESS PANEL:** An opening in the wall or ceiling near the fixture that allows access for servicing the plumbing/electrical system.

**ADAPTOR:** A fitting that unites different types of pipe together, e.g. ABS to cast iron pipe.

**AIR BREAK:** An air break is a physical separation which may be a low inlet into the indirect waste receptor from the fixture, or device that is indirectly connected. You will most likely find an air break on waste fixtures or on non-potable lines. You should never allow an air break on an ice machine.

**AIR GAP SEPARATION:** A physical separation space that is present between the discharge vessel and the receiving vessel, for an example, a kitchen faucet.

**ALTERNATIVE DISINFECTANTS:** Disinfectants - other than chlorination (halogens) - used to treat water, e.g. ozone, ultraviolet radiation, chlorine dioxide, and chloramine. There is limited experience and scientific knowledge about the by-products and risks associated with the use of alternatives.

**AMMONIA:** A chemical made with Nitrogen and Hydrogen and used with chlorine to disinfect water.

**AQUIFER:** An underground geologic formation capable of storing significant amounts of water.

**BACKFLOW PREVENTION:** To stop or prevent the occurrence of the unnatural act of reversing the normal direction of the flow of liquids, gases, or solid substances back into the public potable (drinking) water supply. See Cross-connection control.

**BACKFLOW:** To reverse the natural and normal directional flow of liquids, gases, or solid substances back in to the public potable (drinking) water supply. This is normally an undesirable effect.

**BACKSIPHONAGE:** A liquid substance that is carried over a higher point. It is the method by which the liquid substance may be forced by excess pressure over or into a higher point.

**BENCHING:** A method of protecting employees from cave-ins by excavating the sides of an excavation to form one or a series of horizontal levels or steps, usually with vertical or near vertical surfaces between levels.

**BREAK POINT CHLORINATION:** The process of chlorinating the water with significant quantities of chlorine to oxidize all contaminants and organic wastes and leave all remaining chlorine as free chlorine.

**BROMINE:** Chemical disinfectant (HALOGEN) that kills bacteria and algae.

**BUFFER:** Chemical that resists pH change, e.g. sodium bicarbonate.

**CALCIUM HARDNESS:** A measure of the calcium salts dissolved in water.

**CAUSTIC SODA:** Also known as sodium hydroxide and is used to raise pH.

**CAVE-IN:** The separation of a mass of soil or rock material from the side of an excavation, or the loss of soil from under a trench shield or support system, and its sudden movement into the excavation, either by failing or sliding, in sufficient quantity so that it could entrap, bury, or otherwise injure and immobilize a person.

**CENTRIFUGAL PUMP:** A pump consisting of an impeller fixed on a rotating shaft and enclosed in a casing, having an inlet and a discharge connection. The rotating impeller creates pressure in the liquid by the velocity derived from centrifugal force.

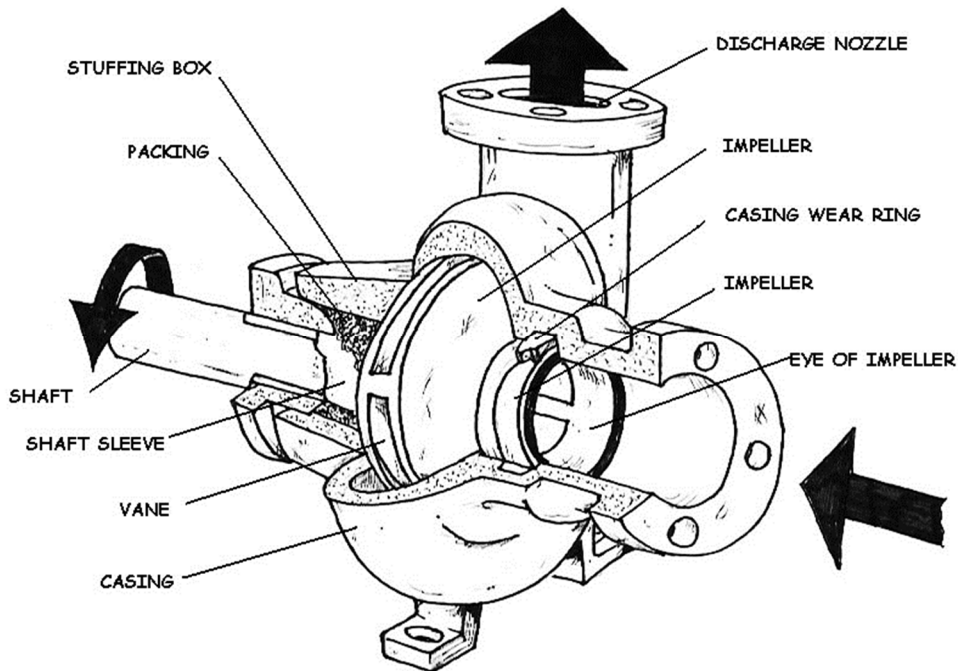

**CHLORAMINATION:** Treating drinking water by applying chlorine before or after ammonia. This creates a persistent disinfectant residual.

**CHLORINATION:** The process in water treatment of adding chlorine (gas or solid hypochlorite) for purposes of disinfection.

**CHLORAMINES:** A group of chlorine ammonia compounds formed when chlorine combines with organic wastes in the water. Chloramines are not effective as disinfectants and are responsible for eye and skin irritation as well as strong chlorine odors (also known as Combined Chlorine).

**CHLORINE:** A chemical which destroys small organisms in water. Chemical disinfectant that kills bacteria and algae.

**CHLORINE DEMAND:** Amount of chlorine required to react on various water impurities before a residual is obtained. Also, means the amount of chlorine required to produce a free chlorine residual of 0.1 mg/l after a contact time of fifteen minutes as measured by iodometric method of a sample at a temperature of twenty degrees in conformance with Standard methods.

**CHLORINE, FREE:** Chlorine available to kill bacteria or algae. The amount of chlorine available for sanitization after the chlorine demand has been met. Also known as chlorine residual.

**CLEANOUT:** A plug in a trap or drain pipe that provides access for the purpose of clearing an obstruction.

**CLOSET AUGER:** A flexible rod with a curved end used to access the toilet's built-in trap and remove clogs.

**CLOSET BEND:** A curved fitting that connects the closet flange to the toilet drain.

**CLOSET FLANGE:** An anchoring ring secured to the floor. The base of the toilet is secured to this ring with bolts.

**COLIFORM:** A group of bacteria commonly found in the environment. They are an indicator of potential contamination of water. Adequate and appropriate disinfection effectively destroys coliform bacteria.

**COMBINED CHLORINE:** The reaction product of chlorine with ammonia or other pollutants, also known as chloramines.

**COMPETENT PERSON:** One who is capable of identifying existing and predictable hazards in the surroundings or working conditions, which are unsanitary, hazardous, or dangerous to employees, and who has authorization to take prompt corrective measures to eliminate them.

**CONTAMINANT:** Any natural or man-made physical, chemical, biological, or radiological substance or matter in water, which is at a level that may have an adverse effect on public health, and which is known or anticipated to occur in public water systems.

**CONTAMINATION:** To make something bad. To pollute or infect something. To reduce the quality of the potable (drinking) water and create an actual hazard to the water supply by poisoning or through spread of diseases.

**CORROSION:** The removal of metal from copper, other metal surfaces and concrete surfaces in a destructive manner. Corrosion is caused by improperly balanced water or excessive water velocity through piping or heat exchangers.

**COUPLING:** A fitting that joins two pieces of pipe.

**CPVC (Chlorinated Polyvinyl Chloride):** Rigid plastic pipe used in water supply systems, where code permits.

**CROSS-CONTAMINATION:** The mixing of two unlike qualities of water. For example, the mixing of good water with a polluting substance like a chemical.

**CRYPTOSPORIDIUM:** A disease-causing parasite, resistant to chlorine disinfection. It may be found in fecal matter or contaminated drinking water.

**DISINFECT:** To kill and inhibit growth of harmful bacterial and viruses in drinking water.

**DISINFECTION BY-PRODUCTS (DBPs):** The products created due to the reaction of chlorine with organic materials (e.g. leaves, soil) present in raw water during the water treatment process. The EPA has determined that these DBPs can cause cancer.

**DISINFECTION:** The treatment of water to inactivate, destroy, and/or remove pathogenic bacteria, viruses, protozoa, and other parasites.

**DWV:** Abbreviation for drain, waste and vent.

**E. COLI, Escherichia coli:** is a bacterium commonly found in the human intestine. For water quality analyses purposes, it is considered an indicator organism. These are considered evidence of water contamination. Indicator organisms may be accompanied by pathogens, but do not necessarily cause disease themselves.

**ELBOW:** A pipe fitting with two openings that changes the direction of the line. Also called an ell. It comes in a variety of angles, from 22 1/2° to 90°.

**ELEVATION HEAD:** The energy possessed per unit weight of a fluid because of its elevation. 1 foot of water will produce .433 pounds of pressure head.

**ENERGY:** The ability to do work. Energy can exist in one of several forms, such as heat, light, mechanical, electrical, or chemical. Energy can be transferred to different forms. It also can exist in one of two states, either potential or kinetic.

**ENHANCED COAGULATION:** The process of joining together particles in water to help remove organic matter.

**ENTEROVIRUS:** A virus whose presence may indicate contaminated water; a virus which may infect the gastrointestinal tract of humans.

**FALL-FLOW:** The proper slope or pitch of a pipe for adequate drainage.

**FECAL COLIFORM:** A group of bacteria that may indicate the presence of human or animal fecal matter in water.

**FILTRATION:** A series of processes that physically remove particles from water.

**FINISHED WATER:** Treated drinking water that meets state and federal drinking water regulations.

**FIXTURE:** In plumbing, the devices that provide a supply of water and/or its disposal, e.g. sinks, tubs, toilets.

**FLOCCULATION:** The process of bringing together destabilized or coagulated particles to form larger masses which can be settled and/or filtered out of the water being treated.

**FLOOD RIM:** The point of an object where the water would run over the edge of something and begin to cause a flood. See Air Break.

**FLUX:** The paste that is used in soldering metal joints. Flux aids the process by preventing oxidation of the joint.

**GIARDIA LAMBLIA:** A pathogenic parasite which may be found in contaminated water.

**HAZARDOUS ATMOSPHERE:** An atmosphere which by reason of being explosive, flammable, poisonous, corrosive, oxidizing, irritating, oxygen deficient, toxic, or otherwise harmful, may cause death, illness, or injury.

**HEAD:** The measure of the pressure of water, expressed in feet, of height of water. 1 psi = 2.41 feet of water. There are various types of heads of water depending upon what is being measured; for example, Static (water at rest) and Residual (water at flow conditions).

**HEADWORKS:** The facility at the "head" of the water source where water is first treated and routed into the distribution system.

**HETEROTROPHIC PLATE COUNT BACTERIA:** A broad group of bacteria including non-pathogens, pathogens, and opportunistic pathogens; they may be an indicator of poor general biological quality of drinking water. Often referred to as HPC.

**I.D.:** Abbreviation for inside diameter. All pipes are sized according to their inside diameter.

**INFECTIOUS PATHOGENS/ MICROBES/GERMS:** Disease-producing bacteria, viruses and other microorganisms.

**IRRIGATION:** Water that is especially furnished to help provide and sustain the life of growing plants. It comes from ditches, and it is sometimes treated with herbicides and pesticides to prevent the growth of weeds and the development of bugs in a lawn or garden.

**KINETIC ENERGY:** The ability of an object to do work by virtue of its motion. The energy terms that are used to describe the operation of a pump are pressure and head.

**LANGELIER INDEX:** A mathematically derived factor obtained from the values of calcium hardness, total alkalinity, and pH at a given temperature. A Langelier index of zero indicates perfect water balance (i.e., neither corroding nor scaling).

**MAXIMUM CONTAMINANT LEVELS (MCLs):** The maximum allowable level of a contaminant that federal or state regulations allow in a public water system. If the MCL is exceeded, the water system must treat the water so that it meets the MCL. Or provide adequate backflow protection.

**MECHANICAL SEAL:** A mechanical device used to control leakage from the stuffing box of a pump. Usually made of two flat surfaces, one of which rotates on the shaft. The two flat surfaces are of such tolerances as to prevent the passage of water between them.

**Mg/L:** milligrams per liter

**MICROBE, MICROBIAL:** Any minute, simple, single-celled form of life, especially one that causes disease.

**MICROBIAL CONTAMINANTS:** Microscopic organisms present in untreated water that can cause waterborne diseases.

**mL:** milliliter.

**NON-CHLORINE SHOCK:** Oxygen based shocking compound. Non Chlorine shock is fast dissolving so it allows swimming just 15 minutes after use.

**NTU (nephelometric turbidity unit):** A measure of the clarity of water.

**O.D.:** Abbreviation for outside diameter.

**OXIDIZING:** The process of breaking down organic wastes into simpler elemental forms or by products. Also used to separate combined chlorine and convert it into free chlorine.

**PATHOGENS:** disease-causing pathogens; waterborne pathogens. A pathogen is a bacterium, virus or parasite that causes or is capable of causing disease. Pathogens may contaminate water and cause waterborne disease.

**pCi/L:** picocuries per liter. A curie is the amount of radiation released by a set amount of a certain compound. A picocurie is one quadrillionth of a curie.

**PIPELINE APPURTENANCE:** Pressure reducers, bends, valves, regulators (which are a type of valve), etc.

**POTABLE:** Good water which is safe for drinking or cooking purposes. Non-Potable: A liquid or water that is not approved for drinking.

**PB (Polybutylene):** Flexible plastic tubing used in water supply systems where allowed by code.

**pH:** A measure of the acidity of water. The pH scale runs from 0 to 14 with 7 being the mid-point or neutral. A pH of less than 7 is on the acid side of the scale with 0 as the point of greatest acid activity. A pH of more than 7 is on the basic (alkaline) side of the scale with 14 as the point of greatest basic activity. pH (Power of Hydroxyl Ion Activity).

**pH OF SATURATION:** The ideal pH for perfect water balance in relation to a particular total alkalinity level and a particular calcium hardness level, at a particular temperature. The pH where the Langelier Index equals zero.

**PHENOL RED:** Chemical reagent used for testing pH in the range of 6.8 - 8.4.

**PLUMBER'S PUTTY:** A pliable, popular putty used to seal joints between drain pieces and fixture surfaces.

**POLLUTION:** To make something unclean or impure. Some states will have a definition of pollution that relates to non-health related water problems, like taste and odors. See Contaminated.

**POTENTIAL ENERGY:** The energy that a body has by virtue of its position or state enabling it to do work.

**ppm:** Abbreviation for parts per million.

**PRE-CHLORINATION:** The addition of chlorine to the water prior to any other plant treatment processes.

**PRESSURE HEAD:** The height to which liquid can be raised by a given pressure.

**PROGRAMMATIC CONSERVATION:** Conservation that results from public education efforts that influence consumer behavior. Examples include turning off the water when brushing your teeth, washing only full loads of laundry, fixing leaks, etc.

**PVC (Polyvinyl Chloride):** A rigid white or cream colored plastic pipe used in non-pressure systems, such as waste and vent systems.

**RAW WATER:** Water that has not been treated in any way; it is generally considered to be unsafe to drink. Sometimes referred to as Auxiliary Water.

**REDUCER:** A fitting that connects pipes of different sizes.

**RESERVOIR:** An impoundment used to store water.

**RESIDUAL DISINFECTION/ PROTECTION:** A required level of disinfectant that remains in treated water to ensure disinfection protection and prevent recontamination throughout the distribution system (i.e., pipes).

**RISER:** A vertical assembly of fittings and pipes that distributes water upward.

**ROUGH-IN:** The portion of a plumbing installation that includes running the water supply lines and drain, waste & vent lines to the proposed location of each fixture.

**RUN:** A complete or secondary section(s) of pipe that extends from supply to fixture or drain to stack.



**SANITARY FITTING:** Fitting that joins the assorted pipes in a drain, waste and vent system; designed to allow solid material to pass through without clogging.

**SANITIZER:** A chemical which disinfects (kills bacteria), kills algae and oxidizes organic matter.

**SCALE:** Crust of calcium carbonate, the result of unbalanced pool water. Hard, insoluble mineral deposits (usually calcium bicarbonate) which form on pool and spa surfaces and clog filters, heaters and pumps. Scale is caused by high calcium hardness and/or high pH. You will often find major scale deposits inside a backflow prevention assembly.

**SEDIMENTATION:** The process of suspended solid particles settling out (going to the bottom of the vessel) in water. The use of a strainer before the backflow assembly can help remove some of the coarse sedimentation.

**SLOPING:** A method of protecting workers from cave-ins by excavating to form sides of an excavation that are inclined away from the excavation to prevent cave-ins. The angle of incline required to prevent a cave-in varies with differences such as soil type, length of exposure, and application of surcharge loads.

**SOIL STACK:** Largest vertical drain line to which all branch waste lines connect; carries waste to the sewer line.

**SOLDER:** A fusible alloy used to join metallic parts. Solder for potable water pipes shall be lead-free.

**SHOCK:** Also known as superchlorination or break-point chlorination. Ridding a pool of organic waste through oxidization by the addition of significant quantities of a halogen.

**SOLDER:** A metal alloy that is melted to join or mend metal surfaces; also, the act of melting solder into the joint.

**STANDPIPE:** A water tank that is taller than it is wide.

**STOP VALVE:** A valve that controls the flow of water to an individual fixture, allowing water supply to be stopped to one fixture without affecting the water supply to other fixtures.

**STUFFING BOX:** That portion of the pump which houses the packing or mechanical seal.

**SUBMERGED:** To cover with water or liquid substance.

**SUPERCHLORINATION:** Application of large dosages of chlorine to destroy buildup of undesirable compounds in water.

**SURFACE WATER:** Water which is open to the atmosphere and subject to surface runoff; generally, lakes, streams, rivers.

**TCE, trichloroethylene:** A solvent and degreaser used for many purposes; for example, dry cleaning is a common groundwater contaminant.

**TITRATION:** method of testing by adding a reagent of known strength to a water sample until a specific color change indicates the completion of the reaction.

**TEE:** A T-shaped fitting with three openings used to create branch lines.

**TOTAL ALKALINITY:** A measure of the acid-neutralizing capacity of water which indicates its buffering ability, i.e. measure of its resistance to a change in pH. Generally, the higher the total alkalinity, the greater the resistance to pH change.

**TOTAL DISSOLVED SOLIDS (TDS) :** The accumulated total of all solids that might be dissolved in water.

**TRAP:** Curved section of a fixture drain line; designed to hold water, thus preventing sewer gases from entering the house.

**TREATED WATER:** Disinfected and/or filtered water served to water system customers. It must meet or surpass all drinking water standards to be considered safe to drink.

**TRENCH:** A narrow excavation below the surface of the ground, less than 15 feet wide, with a depth no greater than the width.

**TRICHALOMETHANES(THM):** Four separate compounds including chloroform, dichlorobromomethane, dibromochloromethane, and bromoform. The most common class of disinfection by-products created when chemical disinfectants react with organic matter in water during the disinfection process. See Disinfectant Byproducts.

**TURBIDITY:** A measure of the cloudiness of water caused by suspended particles.

**UNDERMINING:** Undermining can be caused by such things as leaking, leaching, caving or over-digging. Undermined walls can be very dangerous.

**UNION:** Three-piece fitting that joins two sections of pipe, but allows them to be disconnected without cutting the pipe. Used primarily with steel pipes, but never in a DWV system.

**VALVE:** A device that opens and closes to regulate the flow of liquids. Faucet, hose bib, and Ball are examples of valves.

**VANE:** That portion of an impeller which throws the water toward the volute.

**VELOCITY HEAD:** The vertical distance a liquid must fall to acquire the velocity with which it flows through the piping system. For a given quantity of flow, the velocity head will vary indirectly as the pipe diameter varies.

**VENT STACK:** The upper portion of the soil stack above the topmost fixture through which gases and odors escape.

**VENTURI:** If water flows through a pipeline at a high velocity, the pressure in the pipeline is reduced. Velocities can be increased to a point that a partial vacuum is created.

**VIBRATION:** A force that is present on construction sites and must be considered. The vibrations caused by backhoes, dump trucks, compactors and traffic on job sites can be substantial.

**VOLUTE:** The spiral-shaped casing surrounding a pump impeller that collects the liquid discharge by the impeller.

**WATER WORKS:** All of the pipes, pumps, reservoirs, dams and buildings that make up a water system.

**WATERBORNE DISEASES:** A disease, caused by a virus, bacterium, protozoan, or other microorganism, capable of being transmitted by water (e.g., typhoid fever, cholera, amoebic dysentery, gastroenteritis).

## References

*Several Photographs and Reference were provided by*  
GA Industries, Inc.

WWW. Gaindustries.com  
Telephone (724) 776-1020  
Fax (724) 776-1254  
9025 Marshall Road  
Cranberry Township, PA 16066 USA

CLA-VAL  
P.O. Box 1325  
Newport Beach, CA 92659-0325  
Phone: (949) 722-4800 • 1-800-942-6326  
Fax: (949) 548-5441  
www.cla-val.com  
E-mail: claval@cla-val.com  
US Regional Offices

WESTERN REGION:  
Phone: (951) 687-9145  
1-800-247-9090  
Fax: (951) 687-9954  
E-mail: lvanderk@cla-val.com

SOUTHERN REGION:  
Phone: (281) 759-9590  
1-800-336-7171  
Fax: (281) 759-8938  
E-mail: blindsey@cla-val.com

NORTHERN REGION:  
Phone: (847) 697-1413  
1-800-238-7070  
Fax: (847) 697-5549  
E-mail: djurs@cla-val.com

EASTERN REGION:  
Phone: (703) 721-1923  
1-800-451-3030  
Fax: (703) 721-1927  
E-mail: bmoore@cla-val.com

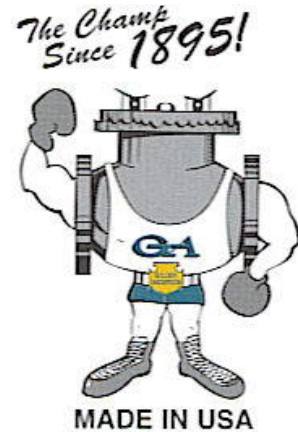



## Math Conversion Factors

1 PSI = 2.31 Feet of Water  
 1 Foot of Water = .433 PSI  
 1.13 Feet of Water = 1 Inch of Mercury  
 454 Grams = 1 Pound  
 2.54 CM = Inch  
 1 Gallon of Water = 8.34 Pounds  
 1 mg/L = 1 PPM  
 17.1 mg/L = 1 Grain/Gallon  
 1% = 10,000 mg/L  
 694 Gallons per Minute = MGD  
 1.55 Cubic Feet per Second = 1 MGD  
 60 Seconds = 1 Minute  
 1440 Minutes = 1 Day  
 .746 kW = 1 Horsepower

### LENGTH

12 Inches = 1 Foot  
 3 Feet = 1 Yard  
 5280 Feet = 1 Mile

### AREA

144 Square Inches = 1 Square Foot  
 43,560 Square Feet = 1 Acre

### VOLUME

1000 Milliliters = 1 Liter  
 3.785 Liters = 1 Gallon  
 231 Cubic Inches = 1 Gallon  
 7.48 Gallons = 1 Cubic Foot of water  
 62.38 Pounds = 1 Cubic Foot of water

## Dimensions

**SQUARE:** Area (sq.ft.) = Length X Width  
 Volume (cu.ft.) = Length (ft) X Width (ft) X Height (ft)

**CIRCLE:** Area (sq.ft.) = 3.14 X Radius (ft) X Radius (ft)

**CYLINDER:** Volume (Cu. ft) = 3.14 X Radius (ft) X Radius (ft) X Depth (ft)

**PIPE VOLUME:** .785 X Diameter<sup>2</sup> X Length = ? To obtain gallons multiply by 7.48

**SPHERE:**  $\frac{(3.14) (\text{Diameter})^3}{(6)}$       Circumference = 3.14 X Diameter

## General Conversions

### Flowrate

Multiply	→	to get
to get	←	Divide
cc/min	1	mL/min
cfm (ft <sup>3</sup> /min)	28.31	L/min
cfm (ft <sup>3</sup> /min)	1.699	m <sup>3</sup> /hr
cfh (ft <sup>3</sup> /hr)	472	mL/min
cfh (ft <sup>3</sup> /hr)	0.125	GPM
GPH	63.1	mL/min
GPH	0.134	cfh
GPM	0.227	m <sup>3</sup> /hr
GPM	3.785	L/min
oz/min	29.57	mL/min

**POUNDS PER DAY** = Concentration (mg/L) X Flow (MG) X 8.34

**AKA Solids Applied Formula** = Flow X Dose X 8.34

$$\text{PERCENT EFFICIENCY} = \frac{\text{In} - \text{Out}}{\text{In}} \times 100$$

$$\begin{aligned} \text{TEMPERATURE: } \quad {}^{\circ}\text{F} &= ({}^{\circ}\text{C} \times 9/5) + 32 & 9/5 &= 1.8 \\ {}^{\circ}\text{C} &= ({}^{\circ}\text{F} - 32) \times 5/9 & 5/9 &= .555 \end{aligned}$$

$$\text{CONCENTRATION: } \text{Conc. (A)} \times \text{Volume (A)} = \text{Conc. (B)} \times \text{Volume (B)}$$

$$\text{FLOW RATE (Q): } Q = A \times V \text{ (Quantity = Area X Velocity)}$$

$$\text{FLOW RATE (gpm): } \text{Flow Rate (gpm)} = \frac{2.83 (\text{Diameter, in})^2 (\text{Distance, in})}{\text{Height, in}}$$

$$\% \text{ SLOPE} = \frac{\text{Rise (feet)}}{\text{Run (feet)}} \times 100$$

$$\text{ACTUAL LEAKAGE} = \frac{\text{Leak Rate (GPD)}}{\text{Length (mi.)} \times \text{Diameter (in)}}$$

$$\text{VELOCITY} = \frac{\text{Distance (ft)}}{\text{Time (Sec)}}$$

**N** = Manning's Coefficient of Roughness

**R** = Hydraulic Radius (ft.)

**S** = Slope of Sewer (ft/ft.)

$$\text{HYDRAULIC RADIUS (ft)} = \frac{\text{Cross Sectional Area of Flow (ft)}}{\text{Wetted pipe Perimeter (ft)}}$$

$$\text{WATER HORSEPOWER} = \frac{\text{Flow (gpm)} \times \text{Head (ft)}}{3960}$$

$$\text{BRAKE HORSEPOWER} = \frac{\text{Flow (gpm)} \times \text{Head (ft)}}{3960 \times \text{Pump Efficiency}}$$

$$\text{MOTOR HORSEPOWER} = \frac{\text{Flow (gpm)} \times \text{Head (ft)}}{3960 \times \text{Pump Eff.} \times \text{Motor Eff.}}$$

$$\text{MEAN OR AVERAGE} = \frac{\text{Sum of the Values}}{\text{Number of Values}}$$

$$\text{TOTAL HEAD (ft)} = \text{Suction Lift (ft)} \times \text{Discharge Head (ft)}$$

$$\text{SURFACE LOADING RATE} = \frac{\text{Flow Rate (gpm)}}{\text{Surface Area (sq. ft)}} \text{ (gal/min/sq.ft)}$$

$$\text{MIXTURE STRENGTH (\%)} = \frac{(\text{Volume 1, gal}) (\text{Strength 1, \%}) + (\text{Volume 2, gal}) (\text{Strength 2, \%})}{(\text{Volume 1, gal}) + (\text{Volume 2, gal})}$$

$$\text{INJURY FREQUENCY RATE} = \frac{(\text{Number of Injuries}) \times 1,000,000}{\text{Number of hours worked per year}}$$

$$\text{DETENTION TIME (hrs)} = \frac{\text{Volume of Basin (gals)} \times 24 \text{ hrs}}{\text{Flow (GPD)}}$$

$$\text{SLOPE} = \frac{\text{Rise (ft)}}{\text{Run (ft)}}$$

$$\text{SLOPE (\%)} = \frac{\text{Rise (ft)} \times 100}{\text{Run (ft)}}$$

**POPULATION EQUIVALENT (PE):**

- 1 PE = .17 Pounds of BOD per Day
- 1 PE = .20 Pounds of Solids per Day
- 1 PE = 100 Gallons per Day

$$\text{LEAKAGE (GPD/inch)} = \frac{\text{Leakage of Water per Day (GPD)}}{\text{Sewer Diameter (inch)}}$$

$$\text{CHLORINE DEMAND (mg/L)} = \text{Chlorine Dose (mg/L)} - \text{Chlorine Residual (mg/L)}$$

**MANNING'S EQUATION**

$\tau Q$  = Allowable time for decrease in pressure from 3.5 PSI to 2.5 PSI

$\tau q$  = As below

$$\tau Q = (0.022) (d_1^2 L_1) / Q \quad \tau q = \frac{[0.085] [(d_1^2 L_1)]}{q}$$

Q = 2.0 cfm air loss

$\theta$  = .0030 cfm air loss per square foot of internal pipe surface

$\delta$  = Pipe diameter (inches)

L = Pipe Length (feet)

$$V = \frac{1.486}{v} R^{2/3} S^{1/2}$$

V = Velocity (ft./sec.)

v = Pipe Roughness

R = Hydraulic Radius (ft)

S = Slope (ft/ft)

$$\text{HYDRAULIC RADIUS (ft)} = \frac{\text{Flow Area (ft. }^2\text{)}}{\text{Wetted Perimeter (ft.)}}$$

$$\text{WIDTH OF TRENCH (ft)} = \text{Base (ft)} + (2 \text{ Sides}) \times \frac{\text{Depth (ft }^2\text{)}}{\text{Slope}}$$





## REFERENCES

- Benenson, Abram S., editor. 1990. *Control of Communicable Diseases in Man*. 15th ed. Baltimore: Victor Graphics, Inc.
- Bick, H. 1972. Ciliated protozoa. An illustrated guide to the species used as biological indicators in freshwater biology. World Health Organization, Geneva. 198 pp.
- Born, Stephen M., Douglas A. Yanggen, and Alexander Zaporozec. *A Guide to Groundwater Quality Planning and Management for Local Governments*. Wisconsin Geological and Natural History Survey, Madison, WI, 1987.
- Cairns, J., and J.A. Ruthven. 1972. A test of the cosmopolitan distribution of fresh-water protozoans. *Hydrobiologia* 39:405-427.
- Cairns, J., and W.H. Yongue. 1977. Factors affecting the number of species of freshwater protozoan communities. Pages 257-303 in J. Cairns, ed. *Aquatic microbial communities*. Garland, New York.
- Cairns, J., G.R. Lanza, and B.C. Parker. 1972. Pollution related structural and functional changes in aquatic communities with emphasis on freshwater algae and protozoa. *Proceedings of the National Academy of Sciences* 124:79-127.
- Concern, Inc. *Groundwater: A Community Action Guide*. Washington, D.C., 1989.
- Cross, Brad L and Jack Schulze. *City of Hurst (A Public Water Supply Protection Strategy)*. Texas Water Commission, Austin, TX, 1989.
- Curds, C.R. 1992. *Protozoa and the water industry*. Cambridge University Press, MA. 122 pp.
- Curtis, Christopher and Teri Anderson. *A Guidebook for Organizing a Community Collection Event: Household Hazardous Waste*. Pioneer Valley Planning Commission and Western Massachusetts Coalition for Safe Waste Management, West Springfield, MA, 1984.
- Curtis, Christopher, Christopher Walsh, and Michael Przybyla. *The Road Salt Management Handbook: Introducing a Reliable Strategy to Safeguard People & Water Resources*. Pioneer Valley Planning Commission, West Springfield, MA, 1986.
- Fenchel, T. 1974. Intrinsic rate increase: the relationship with body size. *Oecologia* 14:317-326.
- Fenchel, T., T. Perry, and A. Thane. 1977. Anaerobiosis and symbiosis with bacteria in free-living ciliates. *Journal of Protozoology* 24:154-163.
- Foissner, W. 1987. Soil protozoa: fundamental problems, ecological significance, adaptations in ciliates and testaceans, bioindicators, and guide to the literature. *Progress in Protistology* 2:69-212.
- Foissner, W. 1988. Taxonomic and nomenclatural revision of Stádecek's list of ciliates (Protozoa: Ciliophora) as indicators of water quality. *Hydrobiologia* 166:1-64.
- Foster, Laurence, M.D. 1985. "Waterborne Disease - It's Our Job to Prevent It". PIPELINE newsletter, Oregon Health Division, Drinking Water Program, Portland, Oregon 1(4 ): 1-3.
- Foster, Laurence, M.D. 1990. "Waterborne Disease," *Methods for the Investigation and Prevention of Waterborne Disease Outbreaks*. Ed. Gunther F. Craun. Cincinnati: U.S. Environmental Protection Agency.
- Giese, A.C. 1973. *Blepharisma*. Stanford University Press, CA. 366 pp.
- Gordon, Wendy. *A Citizen's Handbook on Groundwater Protection*. Natural Resources Defense Council, New York, NY 1984.
- Harrison, Ellen Z. and Mary Ann Dickinson. *Protecting Connecticut's Groundwater: A Guide to Groundwater Protection for Local Officials*. Connecticut Department of Environmental Protection, Hartford, CT, 1984.

Hrezo, Margaret and Pat Nickinson. *Protecting Virginia's Groundwater A Handbook for Local Government Officials*. Virginia Polytechnic Institute and State University, Blacksburg, VA, 1986.

Jaffe, Martin and Frank Dinovo. *Local Groundwater Protection*. American Planning Association, Chicago, IL, 1987.

Kreier, J.P., and J.R. Baker. 1987. Parasitic protozoa. Allen and Unwin, Boston, MA. 241 pp.

Laybourn, J., and B.J. Finlay. 1976. Respiratory energy losses related to cell weight and temperature in ciliated protozoa. *Oecologia* 44:165-174.

Lee, C.C., and T. Fenchel. 1972. Studies on ciliates associated with sea ice from Antarctica. II. Temperature responses and tolerances in ciliates from Antarctica, temperate and tropical habitats. *Archive für Protistenkunde* 114:237-244.

Loomis, George and Yael Calhoun. "Natural Resource Facts: Maintaining Your Septic System." University of Rhode Island, Providence, RI, 1988.

Macozzi, Maureen. *Groundwater- Protecting Wisconsin's Buried Treasure*. Wisconsin Department of Natural Resources, Madison, WI, 1989.

Maine Association of Conservation Commissions. *Ground Water... Maine's Hidden Resource*. Hallowell, ME, 1985.

Massachusetts Audubon Society "Local Authority for Groundwater Protection." Groundwater Information Flyer #4. Lincoln, MA, 1984.

Massachusetts Audubon Society. "Groundwater and Contamination: From the Watershed into the Well." Groundwater Information Flyer # 2. Lincoln, MA, 1984.

Massachusetts Audubon Society. "Mapping Aquifers and Recharge Areas." Groundwater Information Flyer # 3. Lincoln, MA, 1984.

Massachusetts Audubon Society. "Road Salt and Groundwater Protection." Groundwater Information Flyer # 9. Lincoln, MA, 1987.

McCann, Alyson and Thomas P Husband. "Natural Resources Facts: Household Hazardous Waste." University of Rhode Island, Providence, RI; 1988.

Miller, David W. *Groundwater Contamination: A Special Report*. Geraghty & Miller, Inc., Syosset, NY 1982.

Montagnes, D.J.S., D.H. Lynn, J.C. Roff, and W.D. Taylor. 1988. The annual cycle of heterotrophic planktonic ciliates in the waters surrounding the Isles of Shoals, Gulf of Maine: an assessment of their trophic role. *Marine Biology* 99:21-30.

Mullikin, Elizabeth B. *An Ounce of Prevention: A Ground Water Protection Handbook for Local Officials*. Vermont Departments of Water Resources and Environmental Engineering, Health, and Agriculture, Montpelier, VT, 1984.

Murphy, Jim. "Groundwater and Your Town: What Your Town Can Do Right Now." Connecticut Department of Environmental Protection, Hartford, CT.

National Research Council. *Ground Water Quality Protection: State and Local Strategies*. National Academy Press, Washington, D.C., 1986.

New England Interstate Water Pollution Control Commission. "Groundwater: Out of Sight Not Out of Danger." Boston, MA, 1989.

Niederlehner, B.R., K.W. Pontasch, J.R. Pratt, and J. Cairns. 1990. Field evaluation of predictions of environmental effects from multispecies microcosm toxicity test. *Archives of Environmental Contamination and Toxicology* 19:62-71.

Noake, Kimberly D. Guide to *Contamination Sources for Wellhead Protection*. Draft. Massachusetts Department of Environmental Quality Engineering, Boston, MA, 1988.

Office of Drinking Water. *A Local Planning Process for Groundwater Protection*. U.S. EPA, Washington, D.C., 1989.

Office of Ground-Water Protection. *Guidelines for Delineation of Wellhead Protection Areas*. U.S. EPA, Washington, D.C., 1987.

Office of Ground-Water Protection. *Survey of State Ground Water Quality Protection Legislation Enacted From 1985 Through 1987*. U.S. EPA, Washington, D.C., 1988.

Office of Ground-Water Protection. *Wellhead Protection Programs. - Tools for Local Governments*. U.S. EPA, Washington, D.C., 1989.

Office of Ground-Water Protection. *Wellhead Protection: A Decision-Makers' Guide*. U.S. EPA, Washington, D.C., 1987

Office of Pesticides and Toxic Substances. *Citizen's Guide to Pesticides*. U.S. EPA, Washington, D.C., 1989.

Office of Underground Storage Tanks. *Musts for USGS. - A Summary of the New Regulations for Underground Storage Tank Systems*. U.S. EPA, Washington, D.C., 1988.

Ohio Environmental Protection Agency. *Ground Water*. Columbus, OH.

Redlich, Susan. *Summary of Municipal Actions for Groundwater Protection in the New England/New York Region*. New England Interstate Water Pollution Control Commission, Boston, MA, 1988.

Southern Arizona Water Resources Association. "Water Warnings: Our Drinking Water.... It Takes Everyone to Keep It Clean." Tucson, AZ.

Sponenberg, Torsten D. and Jacob H. Kahn. *A Groundwater Primer for Virginians*. Virginia Polytechnic Institute and State University, Blacksburg, VA, 1984.

Taylor, W., and R. Sanders. 1991. Protozoa. Pages 37-93 in J.H. Thorp and A.P. Covich, eds. *Ecology and classification of North American freshwater invertebrates*. Academic Press, New York.

Texas Water Commission. "On Dangerous Ground: The Problem of Abandoned Wells in Texas." Austin, TX, 1989.

Texas Water Commission. *The Underground Subject: An Introduction to Ground Water Issues in Texas*. Austin, TX, 1989.

U.S. Environmental Protection Agency. *Seminar Publication: Protection of Public Water Supplies from Ground-Water Contaminants*. Center for Environmental Research Information, Cincinnati, OH, 1985.

Waller, Roger M. *Ground Water and the Rural Homeowner*. U.S. Geological Survey, Reston, VA, 1988.



We welcome you to complete the assignment in Microsoft Word. You can easily find the assignment at [www.abctlc.com](http://www.abctlc.com).

Once complete, just simply fax or e-mail the answer key along with the registration page to us and allow two weeks for grading.

Once we grade it, we will email a certificate of completion to you.

Call us if you need any help. If you need your certificate back within 48 hours, you may be asked to pay a rush service fee of \$50.00.

You can download the assignment in Microsoft Word from TLC's website under the Assignment Page. [www.abctlc.com](http://www.abctlc.com)

You will have 90 days in order to successfully complete this assignment with a score of 70% or better.

If you need any assistance, please contact TLC's Student Services. Once you are finished, please mail, e-mail or fax your answer sheet along with your registration form.