

# ONSITE 101

## PROFESSIONAL DEVELOPMENT CONTINUING EDUCATION COURSE

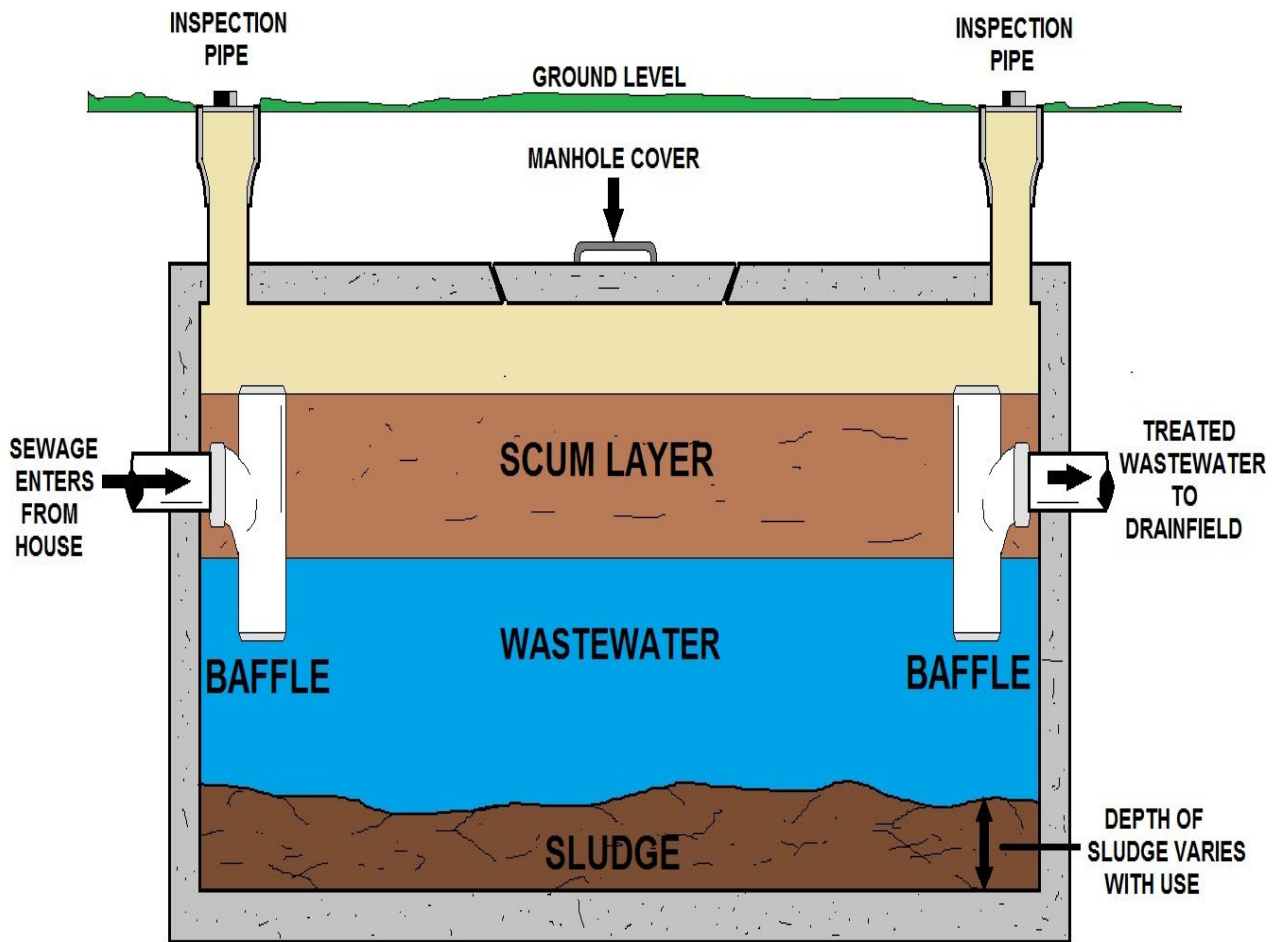

INSIDE OF A SEPTIC TANK



## Printing and Saving Instructions

TLC recommends that you download and save this pdf document and assignment to your computer desktop and open it with Adobe Acrobat DC reader.

Adobe Acrobat DC reader is a free computer software program and you can find it at Adobe Acrobat's website.

You can complete the course by viewing the course on your computer or you can print it out. This course booklet does not have the assignment (the test). Please visit our website and download the assignment (the test).

**Printing Instructions:** Once you have purchased the program, we will give you permission to print this document. If you are going to print this document, it was designed to be printed double-sided or duplexed but can be printed single-sided.

### Internet Link to Assignment...

***<http://www.abctlc.com/downloads/PDF/Onsite101Ass.pdf>***

**State Approval Listing Link,** check to see if your State accepts or has pre-approved this course. Not all States are listed. Not all courses are listed. Do not solely trust our list for it may be outdated. It is your sole responsibility to ensure this course is accepted for credit. No refunds.

**Professional Engineers;** Most states will accept our courses for credit but we do not officially list the States or Agencies acceptance or approvals.

### State Approval Listing URL...

***<http://www.abctlc.com/downloads/PDF/CEU%20State%20Approvals.pdf>***

*You can obtain a printed version from TLC for an additional \$149.95 plus shipping charges.*

**All downloads are electronically tracked and monitored for security purposes.**



**Some States and many employers require the final exam to be proctored.**

**Do not solely depend on TLC's Approval list for it may be outdated.**

**A second certificate of completion for a second State Agency \$50 processing fee.**

Most of our students prefer to do the assignment in Word and e-mail or fax the assignment back to us. We also teach this course in a conventional hands-on class. Call us and schedule a class today.

### ***Responsibility***

*This course contains EPA's federal rule requirements. Please be aware that each state implements septic/wastewater/safety regulations that may be more stringent than EPA's or OSHA's regulations. Check with your state environmental agency for more information. You are solely responsible in ensuring that you abide with your jurisdiction or agency's rules and regulations.*

## **Copyright Notice**

1999-2020 Technical Learning College (TLC) No part of this work may be reproduced or distributed in any form or by any means without TLC's prior written approval. Permission has been sought for all images and text where we believe copyright exists and where the copyright holder is traceable and contactable. Other materials including text and artwork are in the public domain or fair use (the state of belonging or being available to the public as a whole, and therefore not subject to copyright.) All material that is not credited or acknowledged or referenced in the rear of this course is the copyright of Technical Learning College. All other unacknowledged references are in TLC's Safety, Pump, Sampling and Chemistry courses in the rear of those manuals. Most unaccredited photographs have been taken by TLC instructors or TLC students. All written, graphic, photographic or other material is provided for educational information only. We will be pleased to hear from any copyright holder and will make good on your work if any unintentional copyright infringements were made as soon as these issues are brought to the editor's attention. This educational training course and assignment is intended for educational purposes only. Every possible effort was made to ensure that all information provided in this course is accurate. Therefore, Technical Learning College accepts no responsibility or liability whatsoever for the application or misuse of any information included herein.

Requests for acknowledgements or permission to make copies shall be made to the following address: TLC, P.O. Box 3060, Chino Valley, AZ 86323

Information in this document is subject to change without notice. TLC is not liable for errors or omissions appearing in this document.

## **Contributing Editors**

**James L. Six** Received a Bachelor of Science Degree in Civil Engineering from the University of Akron in June of 1976, Registered Professional Engineer in the State of Ohio, Number 45031 (Retired), Class IV Water Supply Operator issued by Ohio EPA, Number WS4-1012914-08, Class II Wastewater Collection System Operator issued by Ohio EPA, Number WC2-1012914-94

**Joseph Camerata** has a BS in Management with honors (magna cum laude). He retired as a Chemist in 2006 having worked in the field of chemical, environmental, and industrial hygiene sampling and analysis for 40 years.

**James Bevan**, Water Quality Inspector S.M.E. Twenty years of experience in the environmental field dealing with all aspects of water regulations on the federal, state, and local levels. Teacher and Proctor in Charge for Backflow Certification Testing at the ASETT Center in Tucson for the past 15 years and possess an Arizona Community College, Special Teaching Certificate in Environmental Studies.

**Dr. Pete Greer** S.M.E., Retired biology instructor, chemistry and biological review.

**Jack White**, Environmental, Health, Safety expert, City of Phoenix. Art Credits.



Always wear all your required safety equipment, including your safety harness in to confined spaces.

Make sure your harness has an annual re-certification too. Otherwise, you should throw your safety harness away and get a new one immediately.

## **Important Information about this Manual**

This manual has been prepared to educate employees in the general awareness of dealing with complex septic, wastewater collection procedures and requirements for safely handling hazardous and toxic materials. The scope of the problem is quite large, requiring a major effort to bring it under control. Employee health and safety, as well as that of the public, depend upon careful application of safe sewer collection procedures.

This manual will cover general laws, regulations, required procedures and generally accepted policies relating to septic and wastewater collection systems. It should be noted, however, that the regulation of wastewater and other hazardous materials is an ongoing process and subject to change over time. For this reason, a list of resources is provided to assist in obtaining the most up-to-date information on various subjects.

This manual is not a guidance document for employees who are involved with pollution control or wastewater treatment. It is not designed to meet the requirements of the United States Environmental Protection Agency (EPA) or Department of Labor-Occupational Safety and Health Administration (OSHA) or state environmental or health departments.

This course manual will provide general educational awareness guidance of onsite/wastewater treatment and wastewater collection. This document is not a detailed wastewater treatment textbook or a comprehensive source book on occupational safety and health.

Technical Learning College or Technical Learning Consultants, Inc. makes no warranty, guarantee, or representation as to the absolute correctness or appropriateness of the information in this manual and assumes no responsibility in connection with the implementation of this information.

It cannot be assumed that this manual contains all measures and concepts required for specific conditions or circumstances. This document should be used for educational guidance and is not considered a legal document.

Individuals who are responsible for the collection of wastewater or the health and safety of workers at septic, wastewater sewer facilities should obtain and comply with the most recent federal, state, and local regulations relevant to these sites and are urged to consult with OSHA, EPA, and other appropriate federal, state, health, and local agencies.





# Technical Learning College's Scope and Function

Welcome to the Program,

Technical Learning College (TLC) offers affordable continuing education for today's working professionals who need to maintain licenses or certifications. TLC holds several different governmental agency approvals for granting of continuing education credit.

TLC's delivery method of continuing education can include traditional types of classroom lectures and distance-based courses or independent study. TLC's distance based or independent study courses are offered in a print - based distance educational format. We will beat any other training competitor's price for the same CEU material or classroom training.

Our courses are designed to be flexible and for you to finish the material at your convenience. Students can also receive course materials through the mail. The CEU course or e-manual will contain all your lessons, activities and instruction to obtain the assignments. All of TLC's CEU courses allow students to submit assignments using e-mail or fax, or by postal mail. (See the course description for more information.)

Students have direct contact with their instructor—primarily by e-mail or telephone. TLC's CEU courses may use such technologies as the World Wide Web, e-mail, CD-ROMs, videotapes and hard copies. (See the course description.) Make sure you have access to the necessary equipment before enrolling; i.e., printer, Microsoft Word and/or Adobe Acrobat Reader. Some courses may require proctored closed-book exams, depending upon your state or employer requirements.

## **Flexible Learning**

At TLC there are no scheduled online sessions or passwords you need contend with, nor are you required to participate in learning teams or groups designed for the "typical" younger campus based student. You will work at your own pace, completing assignments in time frames that work best for you. TLC's method of flexible individualized instruction is designed to provide each student the guidance and support needed for successful course completion.

## **Course Structure**

TLC's online courses combine the best of online delivery and traditional university textbooks. You can easily find the course syllabus, course content, assignments, and the post-exam (Assignment). This student-friendly course design allows you the most flexibility in choosing when and where you will study.

## **Classroom of One**

TLC offers you the best of both worlds. You learn on your own terms, on your own time, but you are never on your own. Once enrolled, you will be assigned a personal Student Service Representative who works with you on an individualized basis throughout your program of study. Course specific faculty members (S.M.E.) are assigned at the beginning of each course providing the academic support you need to successfully complete each course. Please call or email us for assistance.

### **Satisfaction Guaranteed**

We have many years of experience, dealing with thousands of students. We assure you, our customer satisfaction is second to none. This is one reason we have taught more than 40,000 students.

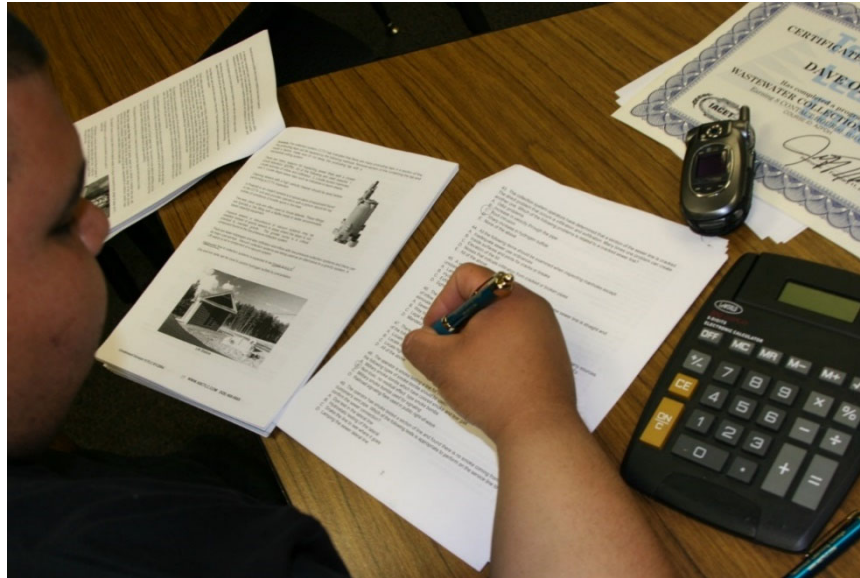

We welcome you to do the electronic version of the assignment and submit the answer key and registration to us either by fax or e-mail.

If you need this assignment graded and a certificate of completion within a 48-hour turn around, prepare to pay an additional rush charge of \$50.

**Contact Numbers**  
**Fax (928) 468-0675**  
**Email [Info@tlch2o.com](mailto:Info@tlch2o.com)**  
**Telephone (866) 557-1746**

## **Course Description**

### **ONSITE 101 CEU COURSE**

This CEU course is designed for the continuing education, knowledge and enhancement of sewer/septic installers, onsite installers, maintenance and service providers. The target audience for this course is the person interested in working in a pumping, installation, collection systems, home sewage treatment systems or septic installation and/or wishing to maintain CEUs for certification license or to learn how to do the job safely and effectively, and/or to meet education needs for promotion. You will not need any other materials for this course.

#### **Course Focus**

This course will cover the operation, maintenance and permitting process ensuring that septic systems are sited and constructed so that human health and the environment are protected. The suitability of a proposed site for a septic system is largely determined by the type and depth of soil and the depth to the water table. This course will cover various onsite factors from the size of the property, how steep the site is, location of the system relative to streams, wells, cuts and fills, and whether sewer service is available.

This CEU course will also review various wastewater-sewer-septic collection, maintenance construction, design, cleaning and detailed safety related subjects. This course is general in nature and not state specific, but it will contain different wastewater collection methods, septic disposal, rules, confined space techniques, maintenance policies, electricity, pump operation, general safety information, and lift station information. Review of the dangers of trenching and excavation and related safety fundamentals. This course will cover the basic requirements of OSHA's Competent Person 29 CFR 1926.650 Subpart F and other related federal safety rules. The Competent Person Program, as it is called, will require formal training and on-the-job experience.

#### **Final Examination for Credit**

Opportunity to pass the final comprehensive examination is limited to three attempts per course enrollment.

#### **Course Procedures for Registration and Support**

All of Technical Learning College's distance learning courses have complete registration and support services offered. Delivery of services will include, e-mail, web site, telephone, fax and mail support. TLC will attempt immediate and prompt service. When a student registers for a correspondence course, he/she is assigned a start date and an end date. It is the student's responsibility to note dates for assignments and keep up with the course work. If a student falls behind, he/she must contact TLC and request an end date extension in order to complete the course. It is the prerogative of TLC to decide whether to grant the request. All students will be tracked by a unique number assigned to the student.

#### **Instructions for Written Assignments**

The Onsite 101 CEU Training course uses a multiple choice style answer key. You can write your answers in this manual or type out your own answer key. TLC would prefer that you fill out and fax or e-mail the final examinations to TLC but it is not required.

#### **Feedback Mechanism (Examination Procedures)**

Each student will receive a feedback form as part of their study packet. You will be able to find this form in the front of the course assignment or lesson.

### **Security and Integrity**

All students are required to do their own work. All lesson sheets and final exams are not returned to the student to discourage sharing of answers. Any fraud or deceit and the student will forfeit all fees and the appropriate agency will be notified.

### **Grading Criteria**

TLC will offer the student either pass/fail or a standard letter grading assignment. If TLC is not notified, you will only receive a pass/fail notice.

### **Required Texts**

The Onsite 101 CEU training course will not require any other materials. This course comes complete. No other materials are needed.

### **Environmental Terms, Abbreviations, and Acronyms**

TLC provides a glossary that defines, in non-technical language, commonly used environmental terms appearing in publications and materials. It also explains abbreviations and acronyms used throughout the EPA and other agencies. You can find the glossary in the manual.

### **Recordkeeping and Reporting Practices**

TLC will keep all student records for a minimum of seven years. It is your responsibility to give the completion certificate to the appropriate agencies. TLC will mail a copy to any State that requires a copy from the Training Provider.

### **ADA Compliance**

TLC will make reasonable accommodations for persons with documented disabilities. Students should notify TLC and their instructors of any special needs.

Course content may vary from this outline to meet the needs of this particular group.

**Prerequisites:** None

**Note to students: Keep a copy of everything that you submit.** If your work is lost you can submit your copy for grading. If you do not receive your certificate of completion or quiz results within two or three weeks after submitting it, please contact your instructor. We expect every student to produce his/her original, independent work.

Any student whose work indicates a violation of the Academic Misconduct Policy (cheating, plagiarism) can expect penalties as specified in the Student Handbook, which is available through Student Services; contact them at (928) 468-0665. A student who registers for a Distance Learning course is assigned a "start date" and an "end date." It is the student's responsibility to note due dates for assignments and to keep up with the course work. If a student falls behind, she/he must contact the instructor and request an extension of her/his *end date* in order to complete the course. It is the prerogative of the instructor to decide whether or not to grant the request.

Your assignments are due on time. Any assignment or mailed-in examination that is one to five days late will be marked down one letter grade. Any assignment or mailed-in examination that is turned in *later* than five days will not be accepted and will be recorded in my grade book as "non-participating" and you can be withdrawn from class. (See final grade options.)

## Continuing Education Units

You will have 90 days from receipt of this manual to complete it in order to receive your Continuing Education Units (CEUs) or Professional Development Hours (PDHs). A score of 70% or better is necessary to pass this course. If you should need any assistance, please visit our Assistance Page on the website. Please e-mail all concerns and the final test to [info@tlch2o.com](mailto:info@tlch2o.com).

## Educational Mission

The educational mission of TLC is:

*To provide TLC students with comprehensive and ongoing training in the theory and skills needed for the environmental education field,*

*To provide TLC students with opportunities to apply and understand the theory and skills needed for operator certification,*

*To provide opportunities for TLC students to learn and practice environmental educational skills with members of the community for the purpose of sharing diverse perspectives and experience,*

*To provide a forum in which students can exchange experiences and ideas related to environmental education,*

*To provide a forum for the collection and dissemination of current information related to environmental education, and to maintain an environment that nurtures academic and personal growth.*

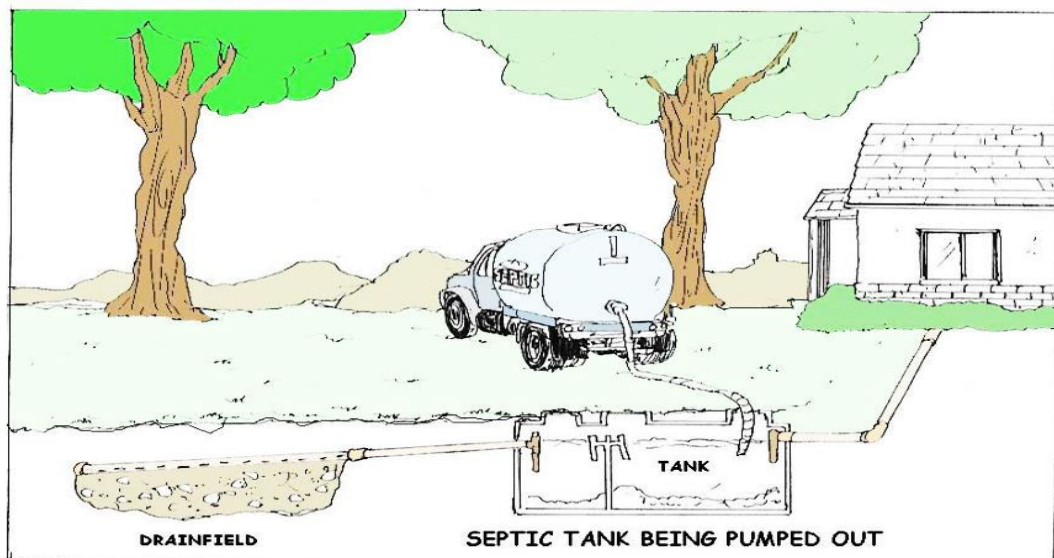

**Course Objective:** To provide continuing education training in effective and efficient sewerage and waste disposal collection methods, pumping, recordkeeping, cleaning, rules, and generally accepted onsite/wastewater treatment/ collection related safety practices.



# TABLE OF CONTENTS

Topic Legend .....	19
Acronyms and Terms.....	21
<b>Chapter 1 –ONSITE INTRODUCTION.....</b>	<b>27</b>
Sewerage System Types - ONSITE & EN.....	29
EPA Regulation- CRAO & O&M & TECH.....	31
Onsite Process Options- ONSITE & EN.....	35
Commonly Found Septic Systems- ONSITE & EN.....	37
Basic Onsite Treatment Process- ONSITE & EN.....	39
Septic System Basics- ONSITE & EN.....	41
Pressure Distribution- ONSITE & EN & TECH.....	42
Conventional Septic System- ONSITE & O&M & TECH.....	43
SWIS Septic Tank Operation- ONSITE & O&M & TECH.....	45
Pretreatment Components- ONSITE & O&M & TECH.....	49
Elevated Mound Systems- ONSITE & O&M & TECH.....	51
Aerobic Treatment Units- ONSITE & O&M & TECH.....	53
Media Filters- ONSITE & O&M & TECH.....	54
Submerged Flow Wetlands- ONSITE & EN & TECH.....	55
Cluster System Applications- ONSITE & O&M & TECH.....	57
Pressure and Drip Systems Introduction- ONSITE & O&M & TECH.....	61
Advanced Systems- ONSITE & O&M & TECH.....	65
Advanced Systems Components- ONSITE & O&M & TECH.....	67
Residual Section- ONSITE & O&M & TECH.....	69
Septage Management- ONSITE & O&M & TECH.....	71
Pumping Frequency Chart- ONSITE & EN & TECH.....	74
Federal Septage Rules- ONSITE & EN & TECH.....	75
Post Quiz.....	83
<b>Chapter 2- ONSITE OPERATION AND MAINTENANCE SECTION.....</b>	<b>85</b>
Septic Failures- ONSITE & EN & TECH.....	87
Regular Maintenance Introduction- ONSITE & O&M & TECH.....	91
Septic System Evaluation- ONSITE & O&M & TECH.....	95
Two Types of Septic Inspections- ONSITE & O&M & TECH.....	101
Sludge and Scum Accumulation- ONSITE & O&M & TECH.....	105
Leach Field Inspection- ONSITE & EN & TECH.....	107
Aerobic Treatment Introduction- ONSITE & O&M & TECH.....	109
Clustered Treatment System Maintenance- ONSITE & O&M & TECH.....	111
Management Considerations- ONSITE & EN & TECH.....	113
Operating Permits- ONSITE & O&M & TECH.....	115
Ponds and Lagoons- ONSITE & O&M & TECH .....	119
Impacts of Effluent on Groundwater- ONSITE & EN & TECH.....	129
Improving OSSF Performance- ONSITE & O&M & TECH.....	135
Performance Based Standards- ONSITE & EN & TECH.....	139
Summary.....	147
References.....	149
Post Quiz.....	151

<b>Chapter 3 – SUBSURFACE WASTEWATER INFILTRATION CONSTRUCTION.....</b>	<b>153</b>
Site Preparation Practices- CRAO & EN & TECH.....	157
Inspector Qualifications - CRAO & EN & TECH.....	159
Installer Training- CRAO & EN & TECH.....	160
Construction Phases- CRAO & EN & TECH.....	161
Soil Investigation Section- CRAO & EN & TECH.....	163
Soil Texture- CRAO & EN & TECH.....	164
Sampling Soils- CRAO & EN & TECH.....	165
Site Limitations- ONSITE & O&M & TECH.....	166
Soil Absorption- ONSITE & O&M & TECH.....	167
System Design Standards- ONSITE & O&M & TECH.....	169
Perc Terms Associated with Saturation- ONSITE & O&M & TECH.....	171
Septic Tank Construction- ONSITE & O&M & TECH.....	173
Bedding and Backfilling- ONSITE & O&M & TECH.....	176
Separation Distance from Limiting Conditions- ONSITE & O&M & TECH.....	179
Subsurface Drainage- ONSITE & O&M & TECH.....	181
Infiltration Surface Loading Limitations- CRAO & EN & TECH.....	183
Organic Loading Rates- CRAO & EN & TECH.....	185
Infiltration Surface- ONSITE & O&M & TECH.....	187
Wastewater Distribution- ONSITE & O&M & TECH.....	189
Gravity Flow- ONSITE & O&M & TECH.....	191
Gravel-less Wastewater Systems- ONSITE & O&M & TECH.....	192
Vadose Zone- ONSITE & O&M & TECH.....	193
Dosed Flow Distribution- ONSITE & O&M & TECH.....	195
Pressure Manifold- ONSITE & O&M & TECH.....	197
Dripline Pressure Networks- ONSITE & O&M & TECH.....	199
Layout of Drip Systems- ONSITE & O&M & TECH.....	201
SWIS Media- ONSITE & O&M & TECH.....	203
Site Protection. - CRAO & EN & TECH.....	204
Post Quiz.....	207
<b>Chapter 4 - WASTEWATER COLLECTION SYSTEM.....</b>	<b>209</b>
Gravity Sanitary Sewer – CO & O&M.....	211
Low-Pressure– CO & O&M .....	231
Manholes– CO & O&M.....	235
CCTV– CO & O&M.....	236
Flow Monitoring– CO & O&M.....	239
Flow Capacity– CO & O&M.....	241
Mapping– CO & O&M .....	243
Chapter Summary.....	245
Post Quiz.....	247
<b>Chapter 5 - COLLECTION SYSTEM OPERATION AND MAINTENANCE.....</b>	<b>249</b>
Sewer Cleaning Section– CO & O&M.....	251
Manhole Inspection– CO & O&M.....	253
Sewer Technology– CO & O&M.....	263
Cleaning Techniques– CO & O&M .....	265
Sewer Rehabilitation– CO & O&M .....	277
Tree Roots– CO & O&M .....	279
Smoking Out Leaks– CO & O&M.....	281
Chapter Summary.....	284



Post Quiz.....	285
<b>Chapter 6 - FATS, OILS AND GREASE.....</b>	<b>287</b>
Grease Traps - CO & O&M.....	291
Interceptors– CO & O&M.....	293
Controlling FOG Discharges- TECHNICAL.& CRAO.....	299
Ways to Recycle FOG. - TECHNICAL.& CRAO.....	301
Best Management Practices (BMPs) - TECHNICAL.& CRAO.....	304
pH Section- TECHNICAL.& CRAO.....	305
Chapter Summary.....	311
Post Quiz.....	313
<b>Chapter 7– COLLECTION RULES &amp; REGULATIONS.....</b>	<b>315</b>
Sanitary Sewer Overflow– CO & O&M.....	319
Combined Sewer Overflows– CO & O&M.....	321
Leading Causes of SSO's – CO & O&M.....	324
Purposes of CMOM Programs– CO & O&M .....	325
CMOM Elements– CO & O&M .....	327
Collection System Management – CO & O&M .....	331
Potential Performance Indicators– CO & O&M.....	333
Hydrogen Sulfide Gas– SAFETY & CO & O&M.....	335
CMOM Summary – CO & O&M.....	339
Pretreatment Preface – CRAO & CO.....	341
Post Quiz.....	343
<b>Chapter 8 – PUMPS AND LIFT STATIONS.....</b>	<b>345</b>
Lift Station Introduction– CO & O&M & PE .....	347
Hydraulic Terms– CO & O&M & PE .....	348
Hydraulic Principle Section– CO & O&M & PE.....	361
Pump Fundamentals– CO & O&M & PE.....	366
Complicated Types of Pump– CO & O&M & PE.....	367
Lift Station O&M– CO & O&M & PE .....	375
Wastewater Pump Introduction– CO & O&M & PE .....	379
Lift Station Inspection– CO & O&M & PE .....	381
Pumps Chapter Highlights– CO & O&M & PE.....	383
Motors– CO & O&M & PE.....	391
Electric Motor Maintenance– CO & O&M & PE.....	407
Pump Definitions.....	411
Post Quiz.....	413
<b>Chapter 9 – HYDROGEN SULFIDE .....</b>	<b>415</b>
Hydrogen Sulfite Gas– CO & O&M & SAFETY.....	417
Chapter Highlights– CO & O&M & SAFETY.....	420
Post Quiz.....	421
<b>Chapter 10– CONFINED SPACE SAFETY SECTION.....</b>	<b>423</b>
Entry Permit Program– CO & O&M & SAFETY.....	433
Hazards – CO & O&M & SAFETY.....	435
Permit Required Confined Space– CO & O&M & SAFETY.....	443
Confined Space Duties– CO & O&M & SAFETY.....	447
Charge of Entry– CO & O&M & SAFETY.....	453

General Rules - – CO & O&M & SAFETY.....	457
Confined Space Training– CO & O&M & SAFETY.....	459
Chapter Summary.....	481
Post Quiz.....	483
<b>Chapter 11 – EXCAVATION SECTION.....</b>	<b>485</b>
Competent Person– CO & O&M & SAFETY.....	489
Excavation Protection Systems– CO & O&M & SAFETY .....	493
Trenching Guidelines– CO & O&M & SAFETY .....	495
Soil Classification– CO & O&M & SAFETY .....	503
One Call Center– CO & O&M & SAFETY .....	511
LOTO Safety– CO & O&M & SAFETY.....	517
Ladder Safety– CO & O&M & SAFETY.....	523
Post Quiz.....	529
Math Conversions.....	531
Bibliography .....	543

**Hyperlink to the Glossary and Appendix**

*<http://www.abctlc.com/downloads/PDF/WWTGlossary.pdf>*

## Need –to-Know Criteria Topic Legend

This CEU course covers several educational topics/functions/purposes of onsite and/or wastewater collection operations. The topics listed below are to assist in determining which educational area is covered in a specific topic area:

**CO:** Having to do with the wastewater collections system leading to the onsite facility or septic tank. Could be regular or emergency work. This is O&M training for Onsite, O&M, Service providers - operators.

**CRAO:** The regulatory and compliance component. May be a requirement of the city, county permitting, compliance, non-compliance, any part of the permitting or permit obtaining procedures. Having to do with water quality or pollutants. May be a requirement of your NPDES or discharge permit. This along with the EPA information is to satisfy the regulatory portion of your operator training.

**ENGINEERING (EN):** Having to do with scientific or engineering principles, laws or theories of onsite or sub-surface onsite wastewater facility or septic tanks or soil analysis or perk testing.

**FLUID MECHANICS (FM):** Having to do with hydraulic or fluid mechanics. A highly technical and specialized engineering field. This may be considered O&M training for many operators or credit for pump engineers or pump mechanics.

**MOTOR:** Having to do with the electrical-mechanical portion of moving water. This may be considered O&M training for many operators. This is O&M training for Onsite, O&M, Service providers - operators.

**O&M:** This area is for normal operation and/or maintenance of the onsite facility, plant and/or sewer collection system. O&M training for many operators.

**ONSITE:** Having to do with installing septic systems. This is O&M training for onsite installers and/or operators. This person is responsible for the proper construction or installation of onsite systems. A maintenance provider who inspects, maintains, or certifies maintenance of onsite systems using alternative treatment technologies, recirculating gravel filters, or sand filters must be certified as a maintenance provider *and* certified by the manufacturer of the system.

**PUMP ENGINEERING (PE):** The technical science of pumping and pump performance principles. May be a law or theory or calculation related to pumping. Information that a pump engineer or Onsite, O&M, Service providers – operators may need.

**SAFETY:** This area is describing process safety procedures. Safety or general training for many operators.

**TECHNICAL:** The mechanical or physical treatment process/component. O&M training for many operators.

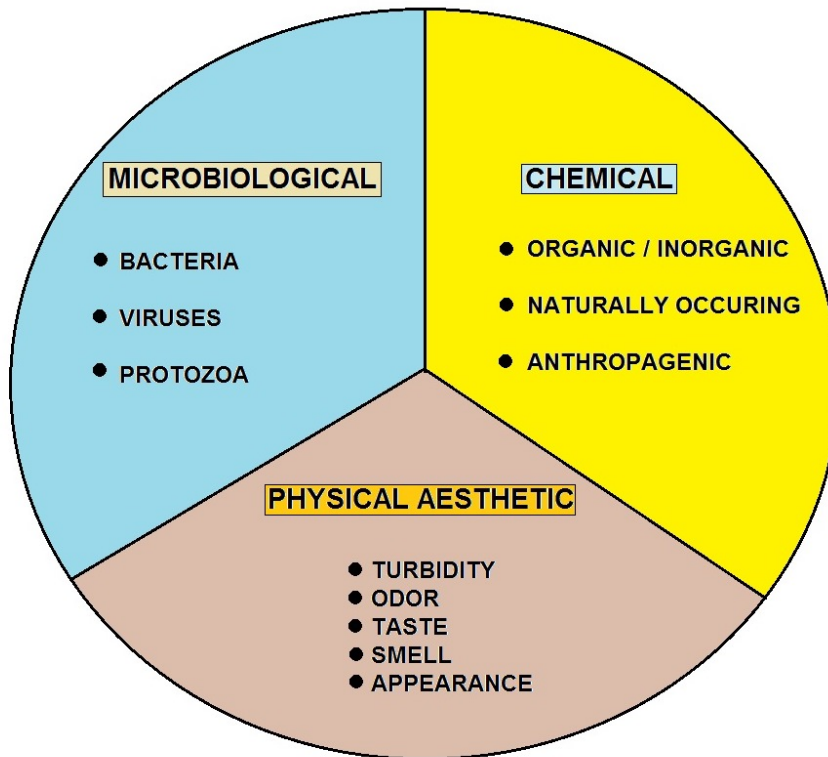

## WATER QUALITY BROKEN DOWN INTO 3 BROAD CATEGORIES

### Sewage and Pollution

Sewage contains nutrients of every type; phosphorus, nitrogen, sodium, potassium, iron, calcium and compounds such as fats, sugars and proteins. Microorganisms use these substances as a “food” source for energy, for the synthesis of cell components and to maintain life processes.

Many types of microorganisms can be found in the wastewater treatment system. However, the types of organisms that will dominate will be the ones that are best suited to the “environment” or conditions in the system. Wastewater treatment systems are designed to foster an “environment” that suits a certain type of microorganism. These microorganisms not only remove organic wastes from the water, but they also “settle out” as solid material for easy removal. Wastewater treatment operators are required to maintain the right conditions in the treatment system for the right type of microorganisms.

While there are many different microbes used in sewage treatment, there are three well-known microbes that play an instrumental role in keeping sewage clean. Each of these types of bacteria help the treatment process in a unique way to ensure there is little to no impact on the surrounding environment.

## Commonly Used Acronyms and Terms

### LIST OF ACRONYMS

<b>AMS</b>	Asset Management System
<b>APP</b>	Aquifer Protection Permit
<b>ASTM</b>	American Society for Testing and Materials
<b>CADD</b>	Computer-Aided Drafting and Design
<b>CCTV</b>	Closed-Circuit Television
<b>CIP</b>	Capital Improvement Plan or capital improvement project
<b>CIPP</b>	Cured-In-Place Pipe
<b>CMMS</b>	Computerized Maintenance Management System
<b>CMOM</b>	Capacity, Management, Operation and Maintenance
<b>COOL</b>	Computerized On-line Operations Log
<b>CPM</b>	Capital Project Management
<b>CWA</b>	Clean Water Act
<b>d/D</b>	depth divided by diameter
<b>DIP</b>	Ductile Iron Pipe
<b>DVD</b>	Digital Video Disk
<b>EPA</b>	Environmental Protection Agency
<b>ERP</b>	Enterprise Resource Planning Software; Emergency Response Plan
<b>FOG</b>	Fats, Oil, and Grease
<b>fps</b>	Feet per second
<b>GIS</b>	Geographic Information System
<b>gpm</b>	Gallons per minute
<b>GPS</b>	Global positioning system
<b>HVAC</b>	Heating, ventilation, and air conditioning
<b>I/I</b>	Infiltration and Inflow
<b>IAS</b>	Information Access System
<b>IGA</b>	Intergovernmental Agreement
<b>IT</b>	Information Technology
<b>JEPA</b>	Joint Exercise of Powers Agreement (SROG)
<b>lf</b>	Linear Feet
<b>mgd</b>	Million gallons per day
<b>NOI</b>	Notice of Intent
<b>NOV</b>	Notice of Violation
<b>NPDES</b>	National Pollutant Discharge Elimination System
<b>O&amp;M</b>	Operation and Maintenance
<b>PLC</b>	Programmable Logic Controller
<b>POTW</b>	Publicly-Owned Treatment Works
<b>Psi</b>	Pounds per square inch

## LIST OF ACRONYMS (continued)

<b>PVC</b>	Polyvinyl Chloride
<b>RDBMS</b>	Relational Database Management System
<b>RFQ</b>	Request for Qualifications
<b>SAI</b>	Southern Avenue Interceptor
<b>SDR35</b>	Standard Dimension Ratio 35
<b>SCADA</b>	Supervisory Control and Data Acquisition
<b>SECAP</b>	System Evaluation and Capacity Assurance Plan
<b>SIU</b>	Significant Industrial User
<b>SROG</b>	Sub-Regional Operating Group
<b>SSO</b>	Sanitary Sewer Overflow
<b>SSORP</b>	Sanitary Sewer Overflow Response Plan
<b>VCC</b>	Virtual Call Center
<b>VCP</b>	Vitrified Clay Pipe
<b>WO</b>	Work order
<b>WRF</b>	Water Reclamation Facility
<b>WRP</b>	Water Reclamation Plant
<b>WTP</b>	Water Treatment Plant
<b>WWTF</b>	Wastewater Treatment Facilities (may include WWTP and WRP)
<b>WWTP</b>	Wastewater Treatment Plant

*This course contains general EPA's CWA federal rule requirements. Please be aware that each state implements septic / wastewater / safety / environmental / building regulations that may be more stringent than EPA's regulations.*

*Check with your state environmental/health agency for more information. These rules change frequently and are often difficult to interpret and follow. Be careful to not be in non-compliance and do not follow this course for proper compliance.*

## Common Onsite/OSSF Terms

**Aerobic Treatment Unit (ATU):** A mechanical wastewater treatment unit that provides secondary wastewater treatment for single home, cluster of homes, or commercial establishments by mixing air (oxygen) and aerobic and facultative microbes with the wastewater. ATUs typically use either a suspended growth process (such as activated sludge, extended aeration and batch reactors), fixed film process (similar to a trickling filter), or a combination of the two treatment processes.

**Alternative Onsite Treatment System:** A wastewater treatment system that includes different components than typically used in a conventional septic tank and subsurface wastewater infiltration system (SWIS). An alternative system is used to achieve acceptable treatment and dispersal of wastewater where conventional systems either may not be capable of protecting public health and water quality, or are inappropriate for properties with shallow soils over groundwater or bedrock or soils with low permeability. Examples of components that may be used in alternative systems include sand filters, aerobic treatment units, disinfection devices, and alternative subsurface infiltration designs such as mounds, gravelless trenches, and pressure and drip distribution.

**Centralized Wastewater System:** A managed system consisting of collection sewers and a single treatment plant used to collect and treat wastewater from an entire service area. Traditionally, such a system has been called a Publicly Owned Treatment Works (POTW) as defined in 40 CFR 122.2.

**Cesspool:** A drywell that receives untreated sanitary waste containing human excreta, which sometimes has an open bottom and/or perforated sides (40 CFR 144.3). Cesspools with the capacity to serve 20 or more persons per day were banned in federal regulations promulgated on December 7, 1999. The construction of new cesspools was immediately banned and existing large-capacity cesspools must be replaced with sewer connections or onsite wastewater treatment systems by 2005.

**Cluster System:** A wastewater collection and treatment system under some form of common ownership which collects wastewater from two or more dwellings or buildings and conveys it to a treatment and dispersal system located on a suitable site near the dwellings or buildings.

**Construction Permit:** A permit issued by the designated local regulatory authority that allows the installation of a wastewater treatment system in accordance with approved plans and applicable codes.

**Conventional Onsite Treatment System:** A wastewater treatment system consisting of a septic tank and a typical trench or bed subsurface wastewater infiltration system.

**Decentralized System:** Managed onsite and/or cluster system(s) used to collect, treat, and disperse or reclaim wastewater from a small community or service area.

**Dispersal System:** A system which receives pretreated wastewater and releases it into the air, surface or ground water, or onto or under the land surface. A subsurface wastewater infiltration system is an example of a dispersal system.

**Engineered Design:** An onsite or cluster wastewater system that is designed and certified by a licensed/certified designer to meet specific performance requirements for a particular wastewater on a particular site.

**Environmental Sensitivity:** The relative susceptibility to adverse impacts of a water resource or other receiving environment from dispersal of wastewater and/or its constituents. The impacts may be low, acute (i.e. immediate and significantly disruptive), or chronic (i.e. long-term, with gradual but serious disruptions).

**Large Capacity Septic System:** A soil dispersal treatment system having the capacity to serve 20 or more persons-per-day subject to EPA's Underground Injection Control regulations.

**Management Model:** A program consisting of thirteen elements that is designed to protect and sustain public health and water quality through the use of appropriate policies and administrative procedures that define and integrate the roles and responsibilities of the regulatory authority, system owner, service providers and management entity, to ensure that onsite and cluster wastewater treatment systems are appropriately managed throughout their life cycle. The program elements include public education and participation, planning, performance requirements, training and certification/licensing, site evaluation, design, construction, operation and maintenance, residuals management, compliance inspections/monitoring, corrective actions and enforcement, record keeping, inventory, and reporting, and financial assistance and funding. Management services should be provided by properly trained and certified personnel and tracked via a comprehensive management information system.

**National Pollutant Discharge Elimination System (NPDES) Permit:** A national program under Section 402 of the Clean Water Act for regulation of discharges of pollutants from point sources to waters of the United States. Discharges are illegal, unless authorized by an NPDES permit.

**Onsite Service Provider:** A person who provides onsite system services. They include but are not limited to designers, engineers, soil scientists, site evaluators, installers, contractors, operators, managers, maintenance service providers, pumpers, and others who provide services to system owners or other service providers.

**Onsite Wastewater Treatment System (OWTS):** A system relying on natural processes and/or mechanical components to collect, treat, and disperse or reclaim wastewater from a single dwelling or building.

**Operating Permit:** A renewable and revocable permit to operate and maintain an onsite or cluster treatment system in compliance with specific operational or performance requirements stipulated by the regulatory authority.

**Performance-Based Management Program:** A program designed to protect public health and water quality by seeking to ensure sustained achievement of specific, measurable performance requirements based on site and risk assessments.

**Performance Requirement:** Any requirement established by the regulatory authority to assure future compliance with the public health and water quality goals of the community, the state or tribe, and the federal government. Performance requirements can be expressed as numeric limits (e.g., pollutant concentrations, mass loads, wet weather flow, structural strength) or narrative descriptions of desired conditions or requirements (e.g., no visible scum, sludge, sheen, odors, cracks, or leaks).



**Permitting Authority:** The state, tribal, or local unit of government with the statutory or delegated authority to issue permits to build and operate onsite wastewater systems.

**Prescription-Based Management Program:** A program designed to preserve and protect public health and water quality through specification of pre-engineered system designs for specific sets of site conditions, which if sited, designed, and constructed properly, are deemed to meet public health and water quality standards.

**Prescriptive Requirements:** Specifications for design, installation and other procedures and practices for onsite or cluster wastewater systems on sites that meet stipulated criteria. Proposed deviations from the stipulated criteria, specifications, procedures, and/or practices require formal approval from the regulatory authority.

**Regulatory Authority (RA):** The unit of government that establishes and enforces codes related to the permitting, design, placement, installation, operation, maintenance, monitoring, and performance of onsite and cluster wastewater systems.

**Residuals:** The solids generated and/or retained during the treatment of wastewater. They include trash, rags, grit, sediment, sludge, biosolids, septage, scum, grease, as well as those portions of treatment systems that have served their useful life and require disposal such as the sand or peat from a filter. Because of their different characteristics, management requirements can differ as stipulated by the appropriate Federal Regulations.

**Responsible Management Entity (RME):** A legal entity responsible for providing various management services with the requisite managerial, financial, and technical capacity to ensure the long-term, cost-effective management of decentralized onsite and/or cluster wastewater treatment facilities in accordance with applicable regulations and performance requirements.

**Septage:** The liquid and solid materials pumped from a septic tank during cleaning operations.

**Septic Tank:** A buried, watertight tank designed and constructed to receive and partially treat raw wastewater. The tank separates and retains settleable and floatable solids suspended in the wastewater and discharges the settled wastewater for further treatment and dispersal to the environment.

**Source Water Assessment:** A study and report required by the Source Water Assessment Program (SWAP) of the Safe Drinking Water Act addressing the capability of a given public water system to protect water quality that includes delineation of the source water area, identification of potential sources of contamination in the delineated area, determination of susceptibility to those sources, and public notice of the completed assessment.

**Underground Injection Well:** A constructed system designed to place waste fluids above, into, or below aquifers classified as underground sources of drinking water. As regulated under the Underground Injection Control (UIC) Program of the Safe Drinking Water Act (40 CFR Parts 144 & 146), injection wells are grouped into five classes. Class 5 includes shallow systems such as cesspools and subsurface wastewater infiltration systems. Subsurface wastewater infiltration systems with the capacity to serve 20 or more people per day, or similar systems receiving non-sanitary wastes, are subject to federal regulation. Class V motor vehicle waste injection wells and large-capacity cesspools are specifically prohibited under the UIC regulations.

### STANDARD SEPTIC SYSTEM

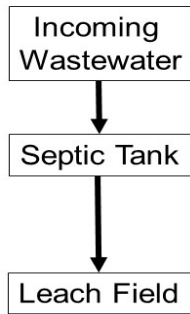

### I/A SEPTIC SYSTEM

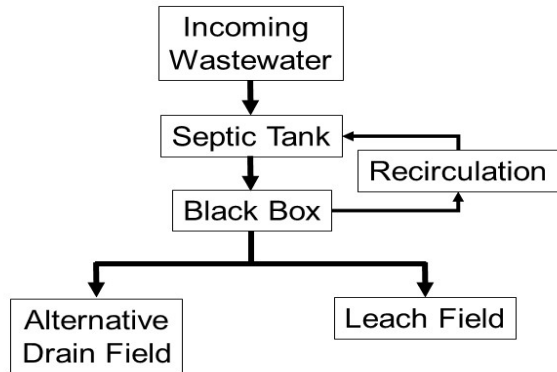

## DIAGRAM OF A SEPTIC SYSTEM

### What are the Components of a Decentralized Wastewater System?

- ✓ Septic systems
- ✓ Onsite sewage systems
- ✓ On-lot sewage systems
- ✓ Private sewage systems
- ✓ Individual sewage systems
- ✓ Cluster, neighborhood or community systems

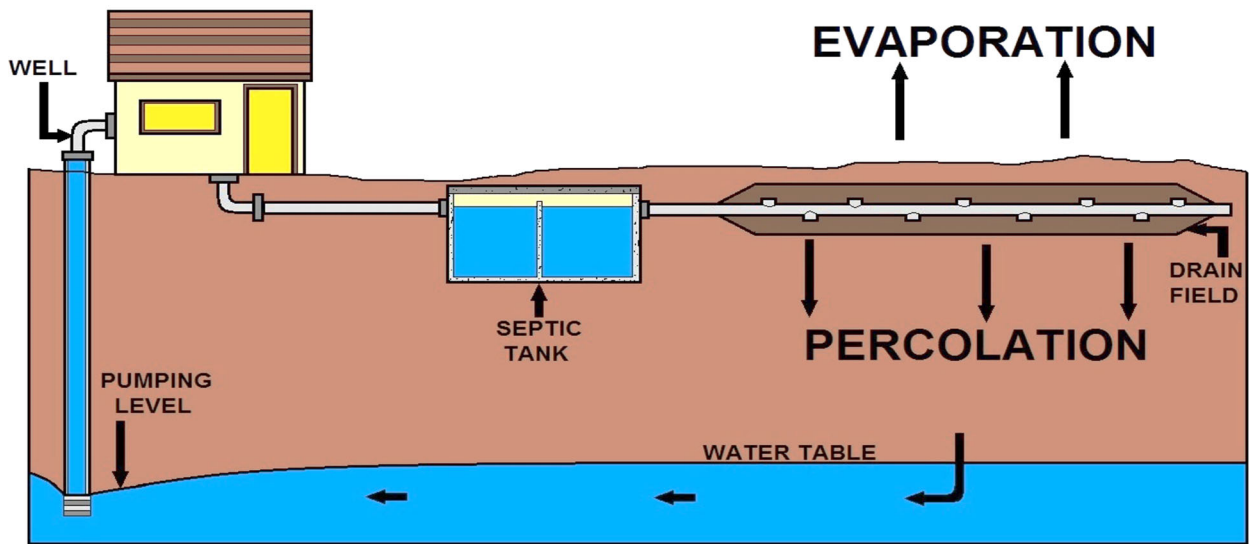

### HOW SEPTIC TANK EFFLUENT PERCOLATES INTO THE WATER TABLE

# Chapter 1 – ONSITE SEWAGE FACILITIES (OSSF) ONSITE SYSTEMS

**Section Focus:** You will learn about the Clean Water Act and the basics of the decentralized or onsite wastewater facility and its operational requirements. At the end of this section, you the student will be able to describe the basics of a decentralized (onsite subsurface wastewater infiltration systems) wastewater facility. There is a post quiz at the end of this section to review your comprehension and a final examination in the Assignment for your contact hours.

**Scope/Background:** Onsite sewage treatment system installers/operators provide and maintain septic systems in compliance with all state and federal requirements and permits to ensure that untreated wastewater will not contaminate the environment or pollute waterways.

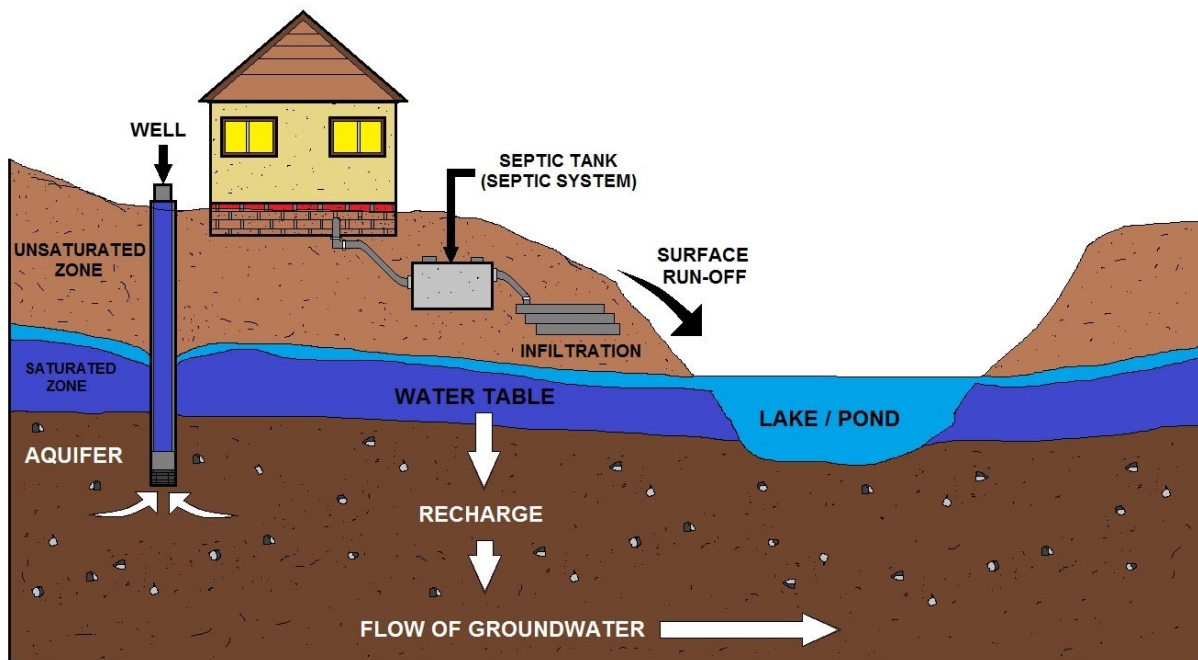

**AN ONSITE WASTEWATER SYSTEM / EFFECTS ON GROUNDWATER**

Onsite sewage treatment system installers/operators provide septic system owners with best management practices to keep their septic systems functioning properly. These practices are really about recycling water: cleaning wastewater and returning safe water to the water cycle. If a septic system is not functioning properly, clean water is not returned to our groundwater systems. Our goal as onsite operators is to ensure that wastewater is properly treated while protecting human and environmental health in a cost-effective manner.

Onsite or septic systems are wastewater systems designed to treat and dispose of effluent on the same property that produces the wastewater.

Onsite/decentralized wastewater treatment systems, commonly called septic systems. These septic systems treat sewage from homes and businesses that are not connected to a centralized wastewater treatment plant.

Decentralized treatment systems include individual onsite septic systems, cluster systems, large septic systems and alternative wastewater treatment technologies like constructed wetlands, recirculating sand filters, mound systems, and ozone disinfection systems.

A septic tank and drainfield combination is the oldest and most common type of OSSF, although newer aerobic and biofilter units exist which represent scaled down versions of municipal sewage treatments. OSSFs account for approximately 25% of all domestic wastewater treatment in the United States.

In the United States, onsite sewage facilities collect, treat, and release about 4 billion US gallons (15,000,000 m<sup>3</sup>) of treated effluent per day from an estimated 26 million homes, businesses, and recreational facilities nationwide (U.S. Census Bureau, 1997).

Recognition of the impacts of onsite systems on ground water and surface water quality (e.g., nitrate and bacteria contamination, nutrient inputs to surface waters) has increased interest in optimizing the systems' performance.

Public health and environmental protection officials now acknowledge that onsite systems are not just temporary installations that will be replaced eventually by centralized sewage treatment services, but permanent approaches to treating wastewater for release and reuse in the environment.

Onsite systems are recognized as viable, low-cost, long-term, decentralized approaches to wastewater treatment if they are planned, designed, installed, operated, and maintained properly (USEPA, 1997).

NOTE: In addition to existing state and local oversight, decentralized wastewater treatment systems that serve more than 20 people might become subject to regulation under the USEPA's Underground Injection Control Program, although EPA has proposed not to include them (64FR22971:5/7/01).

Although some onsite wastewater management programs have functioned successfully in the past, various problems persist. Most current onsite regulatory programs focus on permitting, installation, training and certification.

## Sewerage System Types

We will examine the different types of sewage systems. There are Centralized (public) and Decentralized (private).

Centralized sewer systems are generally broken out into three different categories: sanitary sewers, storm sewers, and combined sewers. Sanitary sewers carry wastewater or sewage from homes and businesses to treatment plants. Underground sanitary sewer pipes can clog or break, causing unintentional "overflows" of raw sewage that flood basements and streets.

Storm sewers are designed to quickly get rainwater off the streets during rain events. Chemical, trash and debris from lawns, parking lots, and streets are washed by the rain into the storm sewer drains. Most storm sewers do not connect with a treatment plant, but instead drain directly into nearby rivers, lakes, or oceans. Combined sewers carry both wastewater and storm water in the same pipe. Most of the time, combined sewers transport the wastewater and storm water to a treatment plant.

However, when there is too much rain, combined sewer systems cannot handle the extra volume and designed "overflows" of raw sewage into streams and rivers occur. The great majority of sewer systems have separated, not combined, sanitary and storm water pipes..

As the infrastructure in the United States and other parts of the world ages, increasing importance is being placed on rehabilitating wastewater collection systems. Cracks, settling, tree root intrusion, and other disturbances that develop over time deteriorate pipelines and other conveyance structures that comprise wastewater collection systems, including stormwater, sanitary, and combined sewers.

Leaking, overflowing, and insufficient wastewater collection systems can release untreated wastewater into receiving waters. Outdated pump stations, undersized to carry sewage from newly developed subdivisions or commercial areas, can also create a potential overflow hazard, adversely affecting human health and degrading the water quality of receiving waters. The maintenance of the sewer system is therefore a continuous, never-ending cycle.

As sections of the system age, problems such as corroded concrete pipe, cracked tile, lost joint integrity, grease, and heavy root intrusion must be constantly monitored and repaired. Technology has improved collection system maintenance with such tools as television camera assisted line inspection equipment, jet-cleaning trucks, and improvements in pump design. Because of the increasing complexity of wastewater collection systems, collection system maintenance is evolving into a highly skilled trade.

Onsite/collection system operators are charged with protecting public health and the environment, and therefore must have documented proof of their certifications in the respective wastewater management systems. You as the operator must ensure that the system pipes remain clear and open. They eliminate obstructions and are constantly striving to improve flow characteristics. They keep the wastewater moving underground, unseen and unheard.

Because this onsite/wastewater collection systems and the professionals who maintain it operate at such a high level of efficiency, problems are very infrequent. So much so that the public often takes the OSSF/wastewater collection system for granted. In truth, these operators must work hard to keep it functioning properly.

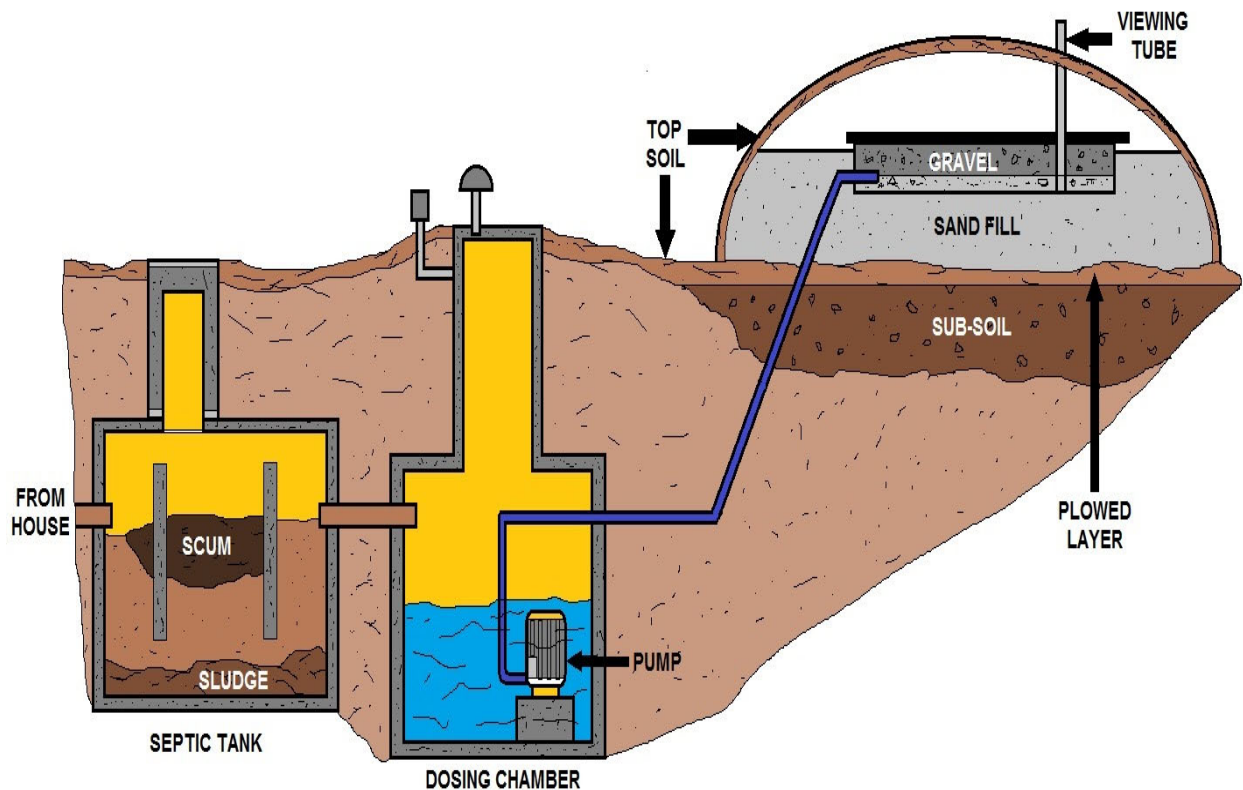

## ABOVE GRADE TREATMENT SYSTEM (Mound System)

Few governmental programs address onsite system operation and maintenance, resulting in failures that lead to unnecessary costs and risks to public health and water resources. Moreover, the lack of coordination among agencies that oversee land use planning, zoning, development, water resource protection, public health initiatives, and onsite systems causes problems that could be prevented through a more cooperative approach.

Effective management of onsite systems requires rigorous planning, design, installation, operation, maintenance, monitoring, and controls.

### **Sewage Disposal Service means:**

- (a) Constructing onsite wastewater treatment systems, including placing portable toilets, or any part of one;
- (b) Pumping out or cleaning onsite wastewater treatment systems, including portable toilets, or any part of one;
- (c) Disposing of material derived from pumping out or cleaning onsite wastewater treatment systems, including portable toilets; or
- (d) Grading, excavating, and earth-moving work connected with the operations described in subsection

## Why is EPA concerned about Onsite Wastewater Treatment Systems?

Onsite wastewater systems include a wide range of individual and cluster treatment systems that process household and commercial sewage. These systems are used in approximately 20 percent of all homes in the United States. An estimated 10 to 20 percent of these systems malfunction each year, causing pollution to the environment and creating a risk to public health.

### Who regulates Onsite Wastewater Treatment Systems?

States, tribes and local governments are responsible for regulating individual onsite systems. EPA provides guidance and technical assistance to help develop and enhance onsite programs.

- EPA regulates large capacity septic systems under the Underground Injection Well program.
- EPA regulates system discharges to surface waters under the National Pollutant Discharge Elimination System.
- EPA regulates disposal of sewage sludge (biosolids) and domestic septage under 40 CFR Part 503.

### What is EPA doing to help manage onsite systems?

- EPA develops voluntary policies and guidance for onsite wastewater management programs.
- EPA sponsors state-of-the-art research on onsite and clustered wastewater system technologies through demonstration projects.
- EPA works with state and local officials, industry professionals, and partner organizations to support onsite wastewater management.
- EPA promotes homeowner awareness to strengthen onsite wastewater management.

Advanced wastewater treatment increases the percentage of contaminants, particularly nitrogen and fecal coliform, removed in wastewater.

Advanced pretreatment components typically follow primary treatment from septic tanks and decrease the constituents of concern before they reach the final treatment and dispersal component.

Advanced pretreatment components are used when a site has a high risk to public or environmental health and primary treatment is not protective enough.

### Key Terms

**Aerobic Sewage Treatment Facility:** Means a sewage treatment plant that incorporates a means of introducing air and oxygen into the sewage to provide aerobic biochemical stabilization during a detention period. Aerobic sewage treatment facilities may include anaerobic processes as part of the treatment system.

**Aerobic System:** Means an alternative system that incorporates a septic tank or other treatment facility, an aerobic sewage treatment facility, and an absorption facility to provide treatment before dispersal.

**Alternative System:** Means any onsite wastewater treatment system DEQ or the Commission approves for use in lieu of the standard subsurface system.

## Onsite Sewer Systems Do's and Don'ts

Do not treat an onsite wastewater treatment system as if it were a normal centralized sewer system (Items flushed down the toilet do not disappear).

### **Do not flush household wastes such as:**

Coffee grinds Kitty Litter Cigarette butts Disposable diapers fat, grease or oil Paper towels  
Feminine hygiene products

### **Do not flush hazardous chemicals, such as:**

Paints, Paint thinners, Medications, Pesticides, Varnishes and Waste oils

Do not build driveways, storage buildings or other structures over the septic tank or drainfield.

Do not send the back-flush water from a water softener into your septic system.

Do divert rainwater coming from driveways and roofs from drainfields. Flooding of the drainfield with excessive water will keep the soil from naturally cleaning the wastewater, leading to groundwater pollution.

Do use water wisely by fixing leaking faucets and toilets, install low-flow devices, take shorter showers and shallower baths, and wash only full loads of dishes and laundry to help reduce the wastewater volume the system must treat. The more wastewater you produce, the more your tank and drainfield must treat. Continuous saturation can affect the quality of the soil and its ability to naturally remove toxins, bacteria, and viruses from the water.

Do maintain a grass cover over drainfield area.

Do use household cleaning materials in moderation. They seldom affect the operation of a septic system when used in moderation.

Do leave stand pipes extending at least 24" above the surface. If you must cut them down be sure to measure and mark their location on a drawing of your system so they may be located for pumping maintenance in the future.

### ***Do not wait until you have a problem - Pump Regularly!***

If the buildup of solids, sludge, in the tank becomes too high, solids move to the drainfield and can clog and strain the system to the point where a new drainfield will be needed. TLC recommends pumping every 2 years. If you have a garbage disposal, hot tub, or whirlpool you should increase the pumping frequency to once a year.

Do not add chemical or biological additives to your septic tank. Because of the cold soil temperatures typically found in Alaska, adding performance enhancing additives like yeast, bacteria or chemicals to your septic tank is of little value. In fact, in some cases, these additives can be harmful to your system or the environment.



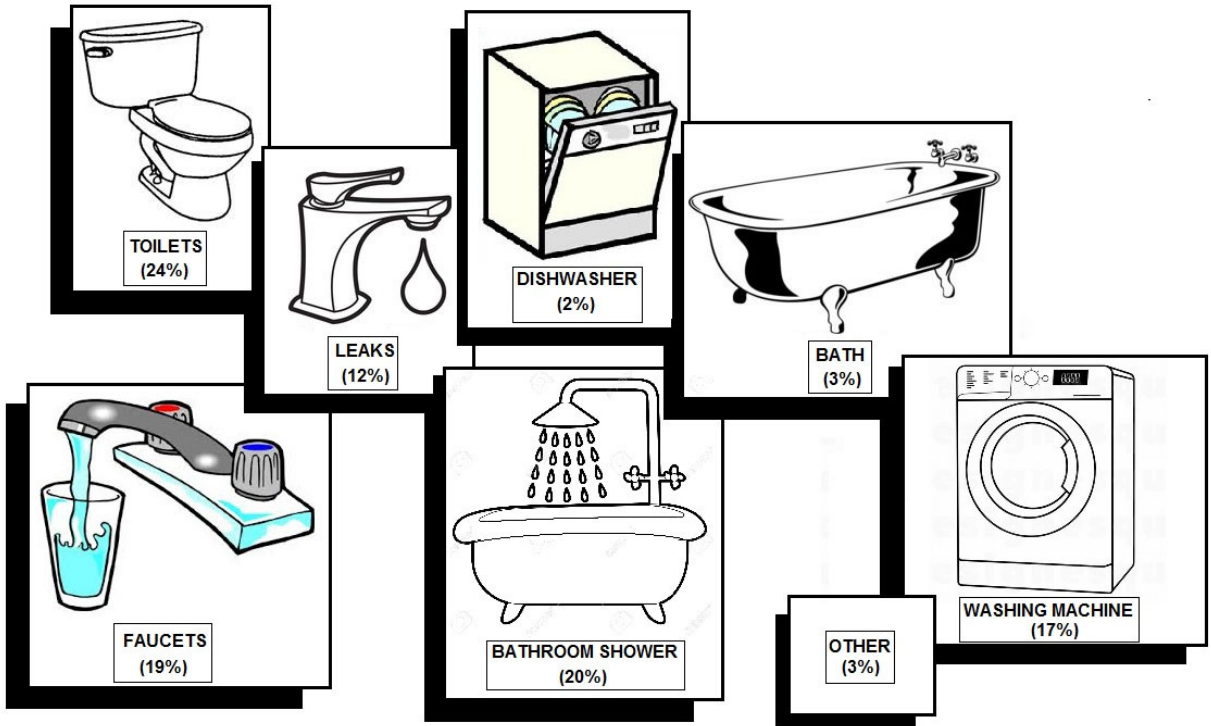

## SEPTIC TANK WATER INPUTS

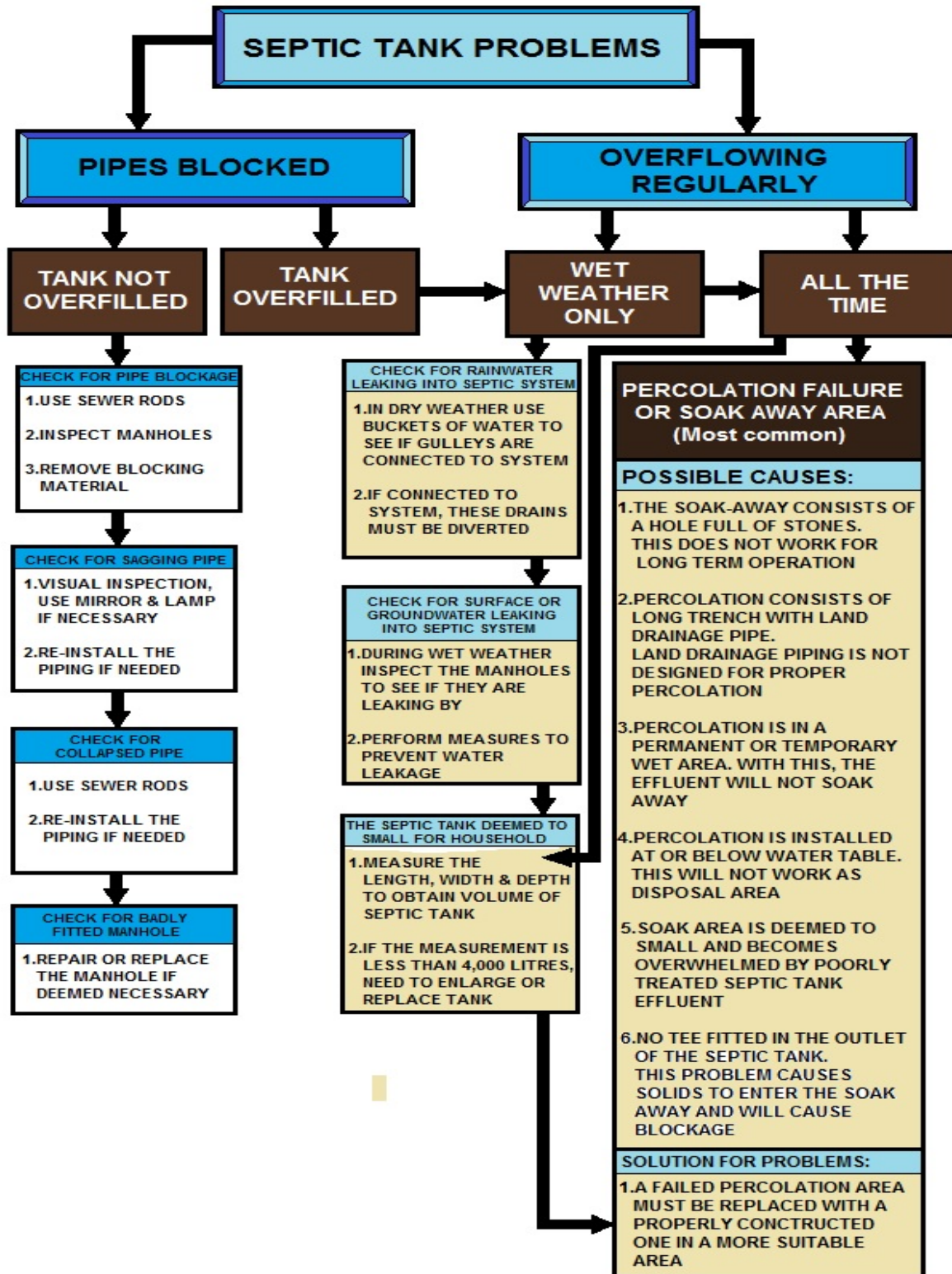

## Onsite Treatment Processes Options

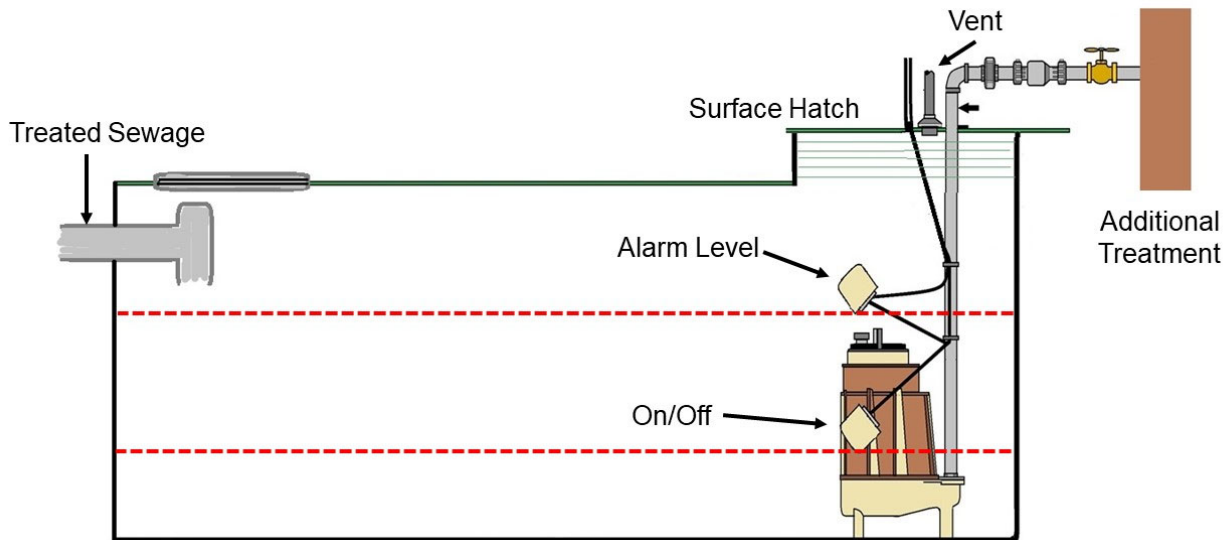

### SEPTIC SYSTEM PUMP TANK

The high cost of centralized wastewater treatment plants and the advances made in individual and cluster (decentralized) system technologies have expanded the array of available treatment options and supported development of a more tailored approach to wastewater management services.

Today, wastewater collection and onsite treatment can be closely matched to the types and quantities of sewage generated through a “just in time” modular approach financed via a “user pays” cost structure.

Options now exist that span the full spectrum of treatment facilities, from large centralized plants, to large and small soil-discharging clustered facilities, to individual treatment systems providing conventional or enhanced service.

#### Key Considerations

Wastewater flow and strength, site and local infrastructure conditions, and performance requirements for the dispersed or discharged effluent are all key considerations in deciding what type of wastewater collection and treatment system is needed and how it should be designed.

Onsite systems treat wastewater and disperse it on the property where it is generated. When functioning properly, onsite systems prevent human contact with sewage, and prevent contamination of surface and groundwater. Factors that affect the proper functioning of onsite systems include the site and soil conditions, design, installation, operation and maintenance.

## **Report to Congress**

Nearly one in four households in the United States depends on an individual septic (onsite) system (referred to as an onsite system) or small community cluster system to treat wastewater. In far too many cases, these systems are installed and largely forgotten - until problems arise.

EPA concluded in its 1997 Report to Congress that "adequately managed decentralized wastewater systems are a cost-effective and long-term option for meeting public health and water quality goals, particularly in less densely populated areas." The difference between failure and success is the implementation of an effective wastewater management program. Such a program, if properly executed, can protect public health, preserve valuable water resources, and maintain economic vitality in a community.

## **Public Health and Water Resource Impacts**

State and tribal agencies report that onsite septic systems currently constitute the third most common source of ground water contamination and that these systems have failed because of inappropriate siting or design or inadequate long-term maintenance (USEPA, 1996a).

In the 1996 Clean Water Needs Survey (USEPA, 1996b), states and tribes also identified more than 500 communities as having failed septic systems that have caused public health problems. The discharge of partially treated sewage from malfunctioning onsite systems was identified as a principal or contributing source of degradation in 32 percent of all harvest-limited shellfish growing areas.

Onsite wastewater treatment systems have also contributed to an overabundance of nutrients in ponds, lakes, and coastal estuaries, leading to the excessive growth of algae and other nuisance aquatic plants (USEPA, 1996b).

In addition, onsite systems contribute to contamination of drinking water sources. USEPA estimates that 168,000 viral illnesses and 34,000 bacterial illnesses occur each year as a result of consumption of drinking water from systems that rely on improperly treated ground water. Malfunctioning septic systems have been identified as one potential source of ground water contamination (USEPA, 2000).

## Commonly Found Decentralized (Septic) Sewage Systems

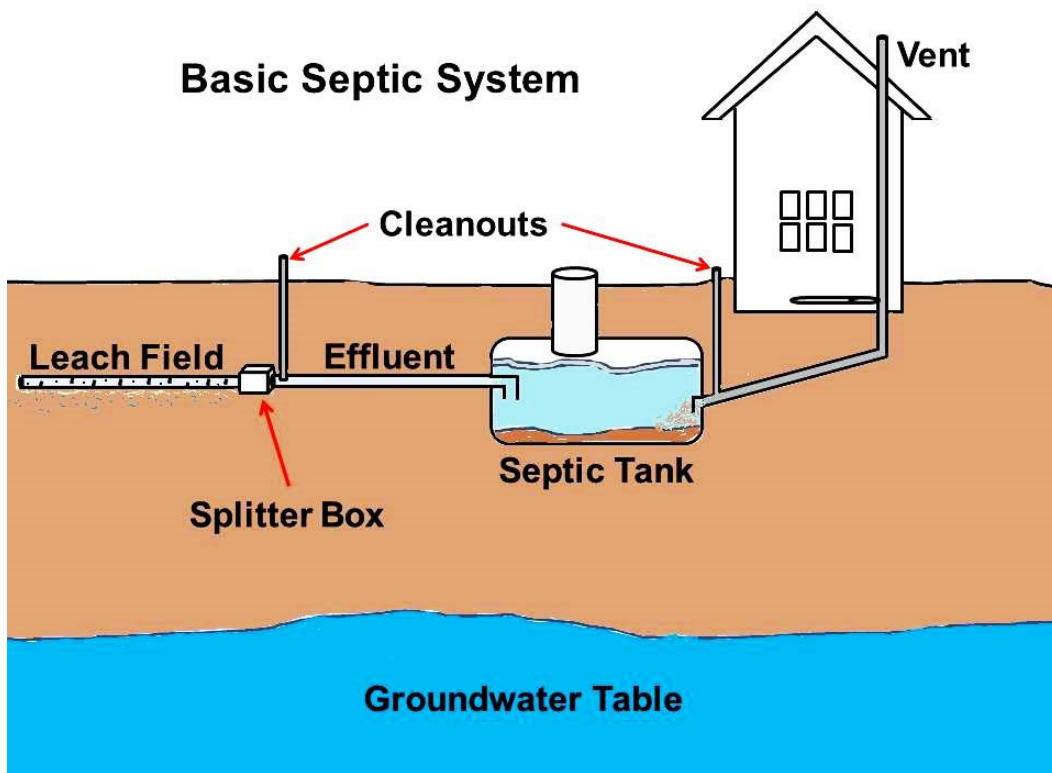
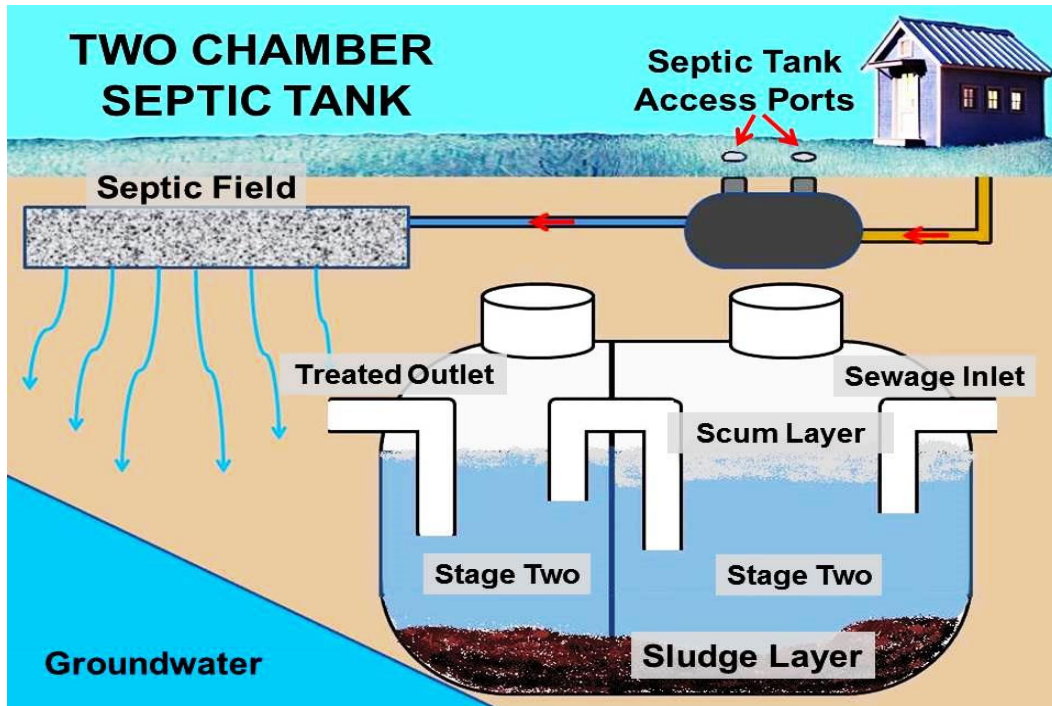

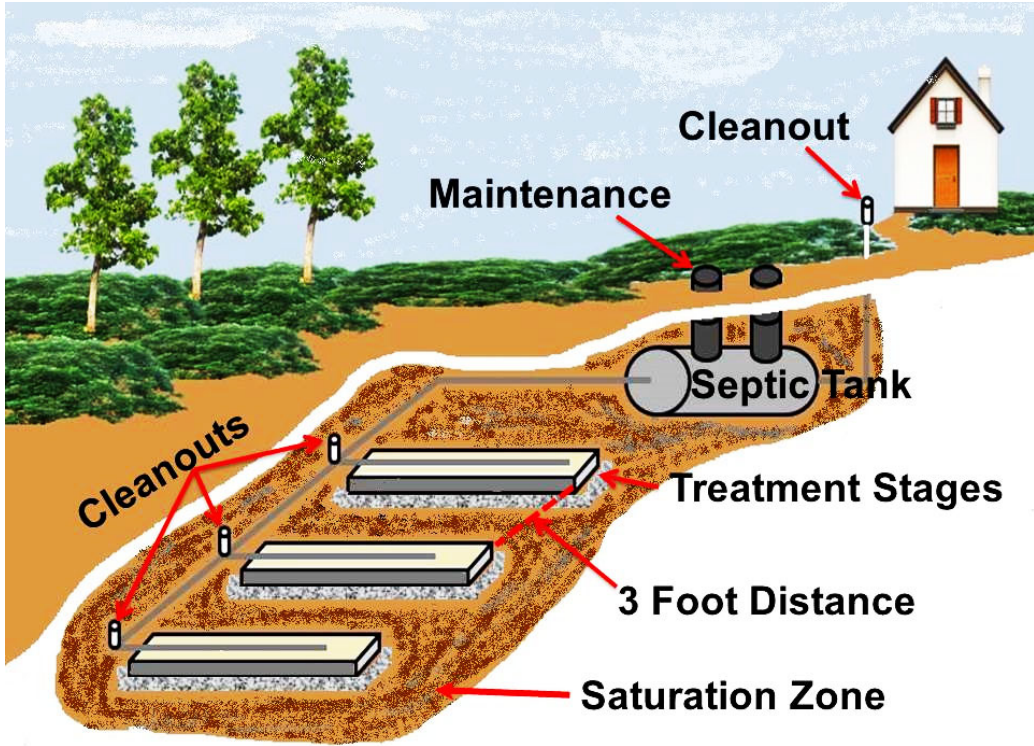

**3 Stage System on top**

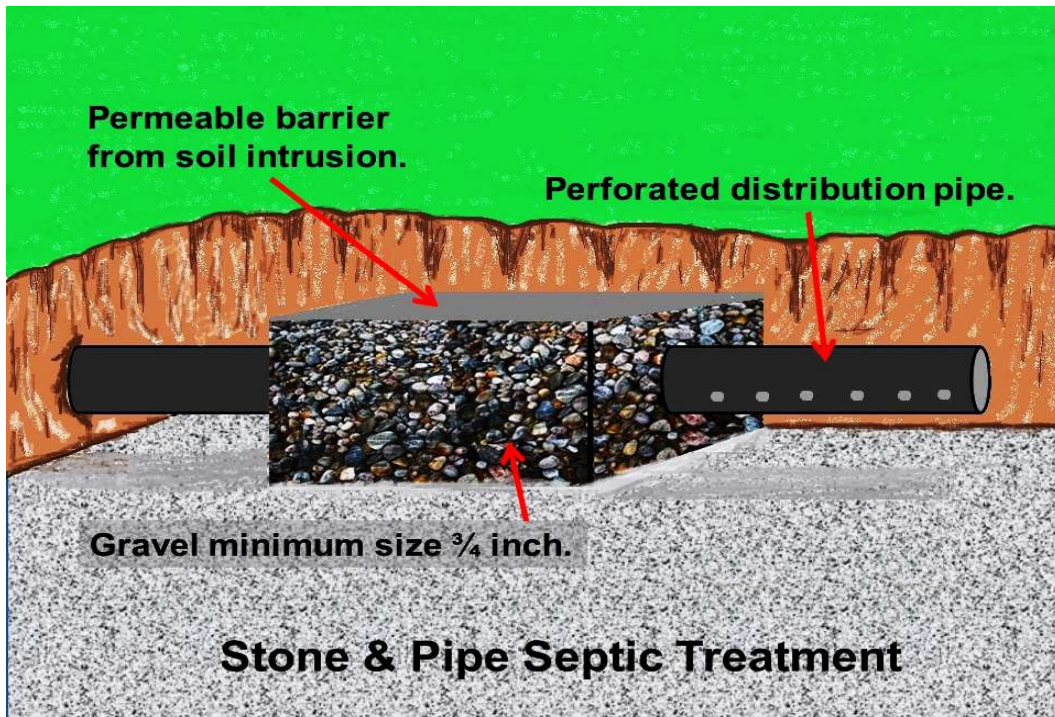

## Basic Onsite Treatment Process

Individual and clustered wastewater systems are designed to accomplish the same thing—the treatment of wastewater—but how this is accomplished is based on the type of treatment technology used. Treatment processes or methods are often described as primary, secondary, and tertiary or advanced, as summarized below:

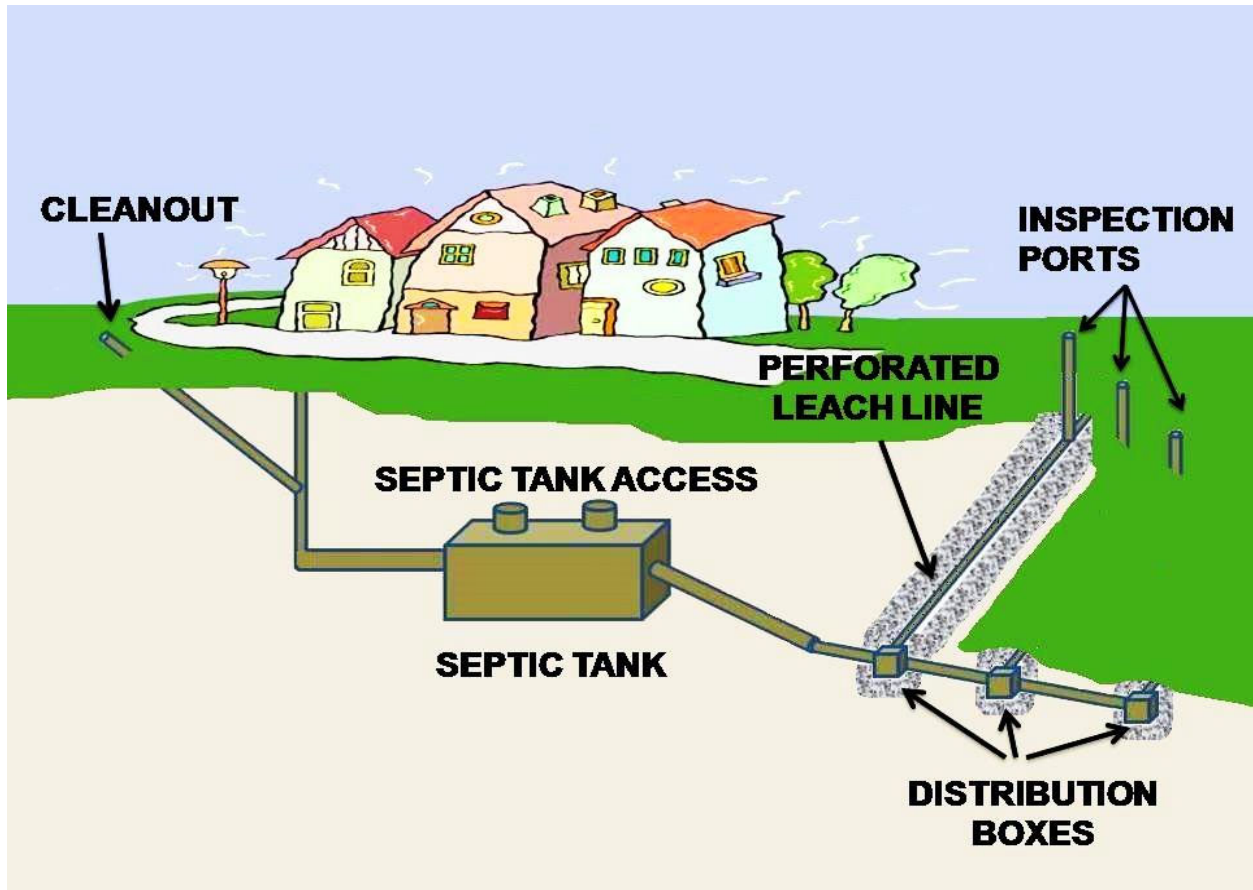

### Primary Treatment

Physical treatment processes involving capture of solids and fats/oils/grease in an enclosed vessel, typically by settling and flotation, such as provided in a septic tank or grease interceptor tank. This process also includes trapping of solids via septic tank effluent filters or screens prior to discharge of the tank effluent.

### Secondary Treatment

Biological and chemical processes designed to remove organic matter, mostly through digestion and decomposition, often aided by introduction of or exposure to atmospheric oxygen.

A typical standard for secondary effluent is biochemical oxygen demand (BOD) and total suspended solids (TSS) concentrations less than or equal to 20 mg/L each on a 30-day average basis. These standards can be achieved via flow through unsaturated soil or other media (e.g., sand, gravel, textile, peat, and plastic media) or within an aerated vessel or chamber.

### **Tertiary (Advanced) Treatment**

Advanced treatment of wastewater includes enhanced organic matter removal, pathogen reduction, and nutrient removal. Standards for advanced or tertiary effluent vary according to regulatory requirements.

Typical effluent quality parameters can include nitrate-nitrogen (e.g., no more than 10-20 mg/l), phosphorus (e.g., 1-5 mg/l or less), and bacteria (fecal coliform less than 10 colony forming units per 100 ml). Advanced treatment can occur via process controls (e.g., alternating oxic/anoxic conditions) or through exposure to additives or media designed to cause chemical or other reactions (e.g., disinfection, phosphorus precipitation). We will cover these in detail later and in the next chapter.

### **Key Septic Terms**

**Alternative System:** Means any onsite wastewater treatment system DEQ or the Commission approves for use in lieu of the standard subsurface system.

**Anaerobic:** The absence of dissolved molecular oxygen.

**Black Waste:** Means human body wastes including feces, urine, other substances of body origin, and toilet paper.

**Cesspool:** Means a lined pit that receives raw sewage, allows separation of solids and liquids, retains the solids, and allows liquids to seep into the surrounding soil through perforations in the lining.

**Effective Seepage Area:** Means the sidewall area within an absorption trench or a seepage trench from the bottom of the trench to a level 2 inches above the distribution pipes, the sidewall area of any cesspool, seepage pit, unsealed earth pit privy, graywater waste absorption sump seepage chamber, or trench with drain media substitute, or the bottom area of a pressurized soil absorption facility installed in soil.

**Equal Distribution:** Means the distribution of effluent to a set of absorption trenches in which each trench receives effluent in equivalent or proportional volumes.

**Holding Tank System:** Means an alternative system consisting of the combination of a holding tank, service riser, and level indicator (alarm), designed to receive and store sewage for intermittent removal for treatment at another location.

**Intermittent Sand Filter:** Means a conventional sand filter.

**Pretreatment:** Means the wastewater treatment that takes place prior to discharging to any component of an onsite wastewater treatment system, including but not limited to pH adjustment, oil and grease removal, BOD5 and TSS reduction, screening, and detoxification.

**Privy:** Means a structure used for disposal of human waste without the aid of water. It consists of a shelter built above a pit or vault in the ground into which human waste falls.



## **Septic System Basics *Described***

The septic system is a natural method of treating and disposing liquid household waste. The first component of all septic systems is the tank. Most tanks are split into two compartments and have pipe baffles and an outlet filter to ensure the solids stay in the tank.

The biologic process begins in the tank where the effluent separates into layers and begins the process of decomposition.

Bacteria, which are naturally present in all septic systems, begin to digest the solids that have settled to the bottom of the tank, transforming a large percentage of these solids into liquids and gases. When liquids within the tank rise to the level of the outflow pipe, they enter the next part of the treatment system (pre-treatment device, distribution box, pump chamber, etc., depending on the type of system). Final treatment of the effluent always occurs in the soil where additional microbes break down the waste and the “clean” water is put back into the ground thereby recharging the aquifers.

Wastewater contains several undesirable pollutants. Pathogens such as viruses or bacteria can enter drinking water supplies creating a potential health hazard.

Nutrients and organic matter entering waterways can lead to tremendous growth in the quantity of aquatic microorganisms. Metabolic activity of these microbes can reduce oxygen levels in the water causing aquatic life to suffocate. Septic system regulations attempt to reduce the chance of these pollutants from having a negative impact on people and animals.

### **Types of Systems – General**

There are many, many types and sizes of septic systems available today. Generally speaking, the systems are divided up into four basic categories:

- Standard Gravity (treatment level “E”)
- Pressure Distribution (treatment level “E”, pressure)
- Advanced Treatment, below ground (treatment level “A” or “B”)
- Advanced Treatment, above ground (treatment level “A” or “B”)

The first two types (standard gravity and pressure distribution) are relatively straightforward, non-proprietary system types.

Standard gravity systems require three feet of “good” soil under the trenches while pressure distribution systems only require two feet.

Advanced Treatment systems are more complicated and treat the wastewater to a fairly high level before allowing it to reach the soil. Because of this treatment, they can be used where there is only one foot of “good” dirt beneath the trench bottom.

Advanced treatment systems come in many makes, models and sizes. Some are proprietary, name brand systems and others are not. We will cover these systems in the next chapter.

Many systems today include pump(s), control panels, graveless infiltration chambers and effluent filters. Some systems even include textile filters, aerobic digestion and/or ultraviolet disinfection!.

### Conventional Septic Systems Typically have three Main Components.

1. A septic tank, this separates the solids from the liquids, and serves a storage area for the solids to decompose and if properly maintained will decompose the solids faster than they build up.
2. A drain field, this allows the separated water to drain out of the system and to absorb into the leach field.
3. Soil is the final treatment area for the effluent water to be treated; microorganisms in the soil will treat the drain water before it percolates out of the system. If installed properly, the conventional system is environmentally safe, long lasting and almost maintenance free. This is why septic system design is so important.

### Pressure Distribution

Pressure distribution systems are usually required when there is less than optimal soil depth available for complete treatment of the effluent by a gravity system. A minimum of two feet of properly drained soil is required under the trenches. The tank and drainfield size are normally the same as a standard gravity system, but the method by which the effluent is distributed to the soil is different.

A pump or sometimes a siphon is used to pressurize the effluent into a small underground pvc pipe which transports it to the drainfield. The drainfield itself consists of pipe and rock, graveless chambers or drip irrigation tubing. Unlike a standard gravity system, a pressure distribution system wets the entire length of the trench each time the pump turns on. This allows the effluent to be spread over a larger area and receive better treatment from the soil.

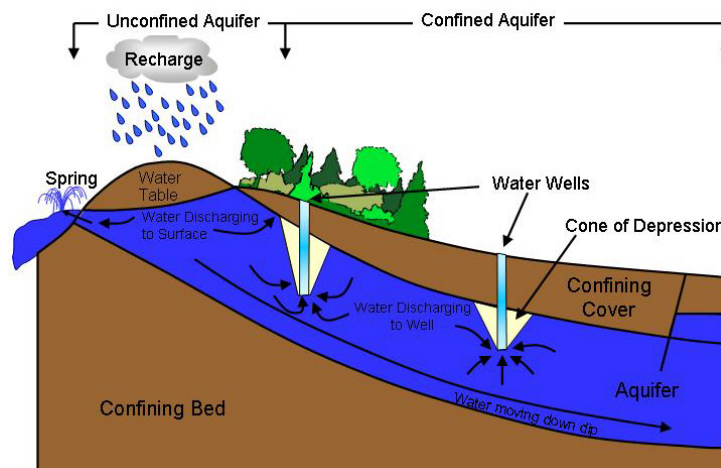

Aquifer Description

### Septic Tanks, Cesspools, and Privies

A major cause of ground-water contamination in many areas of the United States is effluent, or outflow, from septic tanks, cesspools, and privies. Approximately one fourth of all homes in the United States rely on septic systems to dispose of their human wastes. If these systems are improperly sited, designed, constructed, or maintained, they can allow contamination of the ground water by bacteria, nitrates, viruses, synthetic detergents, household chemicals, and chlorides. Although each system can make an insignificant contribution to ground-water contamination, the sheer number of such systems and their widespread use in every area that does not have a public sewage treatment system makes them serious contamination sources.

## Conventional Septic Systems

Conventional treatment systems are the most commonly used wastewater treatment technologies, combining primary and secondary treatment. These systems are the least expensive in terms of total cost but require specific conditions (e.g., at least 24-36 inches of unsaturated soil) and maintenance to perform adequately.

A conventional wastewater treatment system consists of a septic tank and a soil absorption field that allows primary treatment (i.e., septic tank) effluent to infiltrate into unsaturated soil. Flow through the system usually occurs via gravity but can be aided by a pump, if necessary, operated by a float switch or timer.



Conventional systems can serve individual homes or businesses, or clusters of buildings. The most frequently used treatment system design for a single family home is a conventional system serving an individual home. As noted above, the conventional system has two principal parts—the tank and soil absorption field.

The septic tank treats wastewater by allowing floatable materials (e.g., fats, oils, grease) to rise to the surface, forming a scum layer, and the heavier solids to sink to the bottom, creating a layer of sludge. The tank effluent is similar to that of primary sedimentation in larger treatment facilities, except that it is generally devoid of oxygen (i.e., anaerobic).

The soil absorption system facilitates aerobic treatment and filtration of the remaining contaminants. Subsurface discharge of effluent to the soil can be configured to optimize treatment via pressurized time-dosing of preset volumes of treated wastewater, which facilitates oxygenation of the soil matrix between doses, promotes film flow of wastewater over soil particles, and ensures a uniform and consistent application of effluent to the entire drainfield.

The laws of most states and counties prohibit the direct discharge of septic tank effluent onto the ground surface. Surface water discharges must be covered by an approved NPDES permit. Individual systems require periodic pumping of the tank (e.g., every 5-7 years) and inspection of the dispersal field for signs of problems, such as wastewater surfacing, soggy soil, and odor.

Studies of conventional system costs indicate that installation costs can range from \$3,500 to \$6,000 or more, depending on local labor and materials expenses, site conditions, permit fees, and other factors. Annual operation, inspection, and maintenance costs vary, but average about \$30 to \$100 per year, depending on state or local requirements.

When functioning properly, individual or clustered conventional systems are effective in treating or removing pollutants. There are also many advanced technologies that have been developed for situations where conventional systems are not appropriate. The next section discusses alternatives for sites that do not meet minimum requirements for conventional systems or require advanced treatment due to more stringent treatment standards.

### **Basic Onsite Wastewater Treatment Systems and Components**

Building sewers and other sewer lines: watertight pipes, which carry waste by gravity from a building to the onsite system or carry effluent by gravity from sewage tanks to other system components.

#### **Septic Tanks**

A watertight, covered container designed and constructed to receive the discharge of sewage from a building sewer. Its function is to separate solids from liquid, digest organic matter, store liquids through a period of detention and allow the clarified liquids to discharge to other components of an onsite system. Solids are stored and periodically need to be pumped out and hauled to a point for further treatment.

#### **Septic/Sewage Tank Removal**

Unused sewage tanks need to be properly abandoned to prevent them from becoming a safety hazard.

#### **Advanced Pretreatment Components Include:**

- Aerobic treatment units (ATUs)
- Constructed wetlands
- Lagoons

#### **Media Filters:**

- Trickling Filter
- Sand/Gravel Filter
- Foam Filter
- Peat Filter
- Textile Filter
- Upflow Filter

## Subsurface Wastewater Infiltration Systems (SWIS) Operation

A typical septic system consists of a septic tank and a drainfield, or soil absorption field.

The septic tank digests organic matter and separates floatable matter (e.g., oils and grease) and solids from the wastewater. Soil-based systems discharge the liquid (known as effluent) from the septic tank into a series of perforated pipes buried in a leach field, chambers, or other special units designed to slowly release the effluent into the soil.

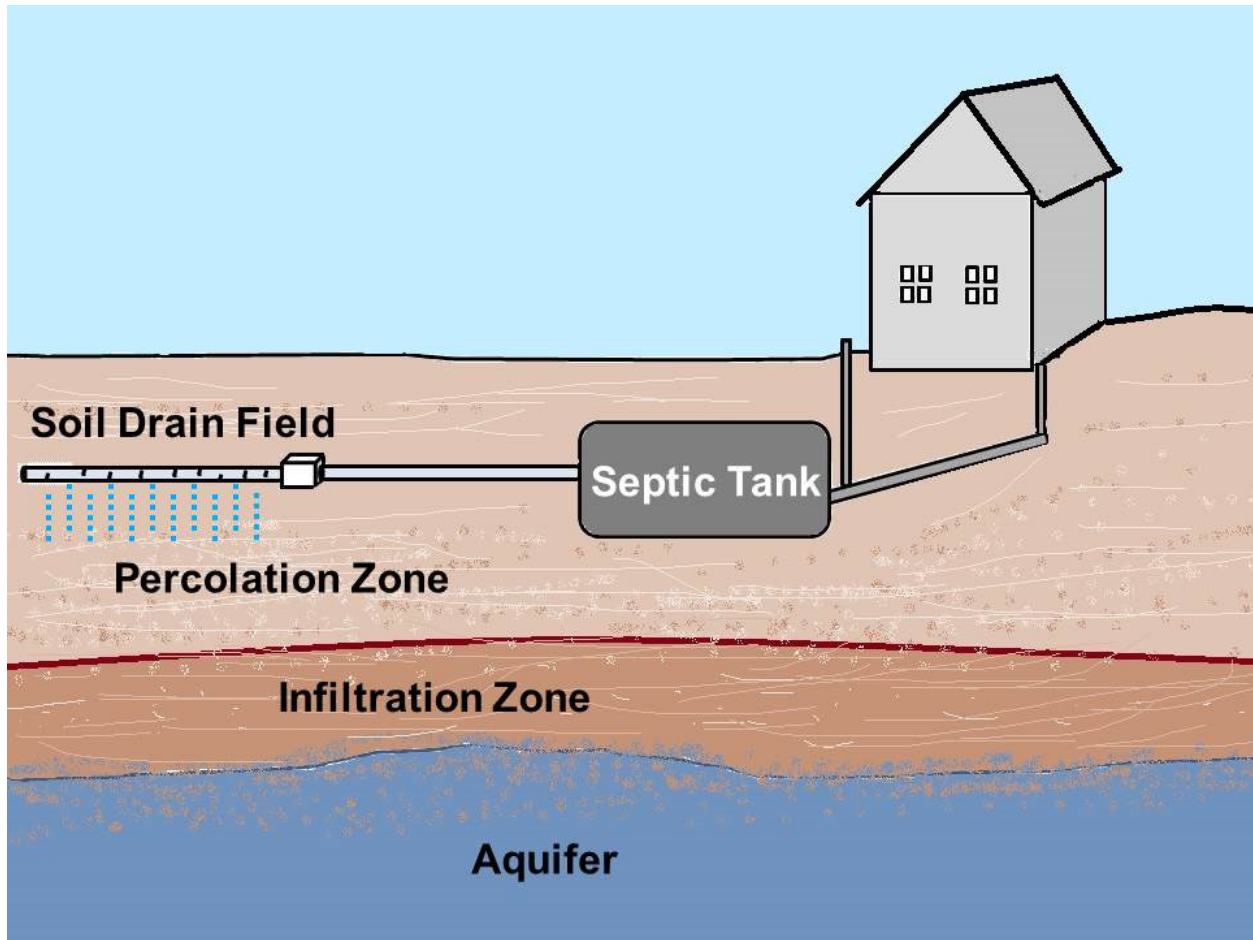

### Septic Treatment

A septic tank removes many of the settleable solids, oils, greases, and floating debris in the raw wastewater, achieving 60 to 80 percent removal (Baumann et al., 1978; Boyer and Rock, 1992; University of Wisconsin, 1978).

The solids removed are stored in sludge and scum layers, where they undergo liquefaction. During liquefaction, the first step in the digestion process, acid forming bacteria partially digest the solids by hydrolyzing the proteins and converting them to volatile fatty acids, most of which are dissolved in the water phase. The volatile fatty acids still exert much of the biochemical oxygen demand that was originally in the organic suspended solids. Because these acids are in the dissolved form, they are able to pass from the tank in the effluent stream, reducing the BOD removal efficiency of septic tanks compared to primary sedimentation.

Typical septic tank BOD removal efficiencies are 30 to 50 percent (Boyer and Rock, 1992; University of Wisconsin, 1978;). Complete digestion, in which the volatile fatty acids are converted to methane, could reduce the amount of BOD released by the tank, but it usually does not occur to a significant extent because wastewater temperatures in septic tanks are typically well below the optimum temperature for methane producing bacteria.

Gases that form from the microbial action in the tank rise in the wastewater column. The rising gas bubbles disturb the quiescent wastewater column, which can reduce the settling efficiency of the tank. They also dislodge colloidal particles in the sludge blanket so they can escape in the water column. At the same time, however, they can carry active anaerobic and facultative microorganisms that might help to treat colloidal and dissolved solids present in the wastewater column (Baumann and Babbit, 1953). Septic tank effluent varies naturally in quality depending on the characteristics of the wastewater and condition of the tank.

## **Typical SWIS Performance**

Results from numerous studies have shown that septic tanks (SWISs) achieve high removal rates of many pollutants of concerns with the notable exception of nitrogen (N). Biochemical oxygen demand (BOD), suspended solids, fecal bacteria indicators and surfactants are effectively removed within 2-5 feet of unsaturated, aerobic soil.

Phosphorous and metals are removed by adsorption, ion exchange and precipitation. However, the retention capacity of the soil is finite and will vary with different types of soil mineralogy, pH, Redox potential and cation exchange capacity. The fate of viruses and toxic organic compounds has not been fully researched.

Field and laboratory studies suggest that the soil is quite effective in removing viruses, but some types of viruses apparently are able to leach from SWISs to the groundwater. Fine textured soils, low hydraulic loadings, aerobic subsoils and high temperatures favor destruction of viruses and toxic organics. The most significant documented threat to our groundwater supply from SWISs are nitrates.

## **Designs and Configurations**

Subsurface wastewater infiltration systems (SWISs) are the most commonly used systems for the treatment and dispersal of onsite wastewater.

Infiltrative surfaces are located in permeable, unsaturated natural soil or imported fill material so wastewater can infiltrate and percolate through the underlying soil to the ground water. As the wastewater infiltrates and percolates through the soil, it is treated through a variety of physical, chemical, and biochemical processes and reactions.

Many different designs and configurations are used, but all incorporate soil infiltrative surfaces that are located in buried excavations. The primary infiltrative surface is the bottom of the excavation, but the sidewalls also may be used for infiltration. Perforated pipe is installed to distribute the wastewater over the infiltration surface.

A porous medium, typically gravel or crushed rock, is placed in the excavation below and around the distribution piping to support the pipe and spread the localized flow from the distribution pipes across the excavation cavity.

## **Gravelless System**

Other gravelless or "aggregate-free" system components may be substituted. The porous medium maintains the structure of the excavation, exposes the applied wastewater to more infiltrative surface, and provides storage space for the wastewater within its void fractions (interstitial spaces, typically 30 to 40 percent of the volume) during peak flows with gravity systems.

A permeable geotextile fabric or other suitable material is laid over the porous medium before the excavation is backfilled to prevent the introduction of backfill material into the porous medium. Natural soil is typically used for backfilling, and the surface of the backfill is usually slightly mounded and seeded with grass.

Subsurface wastewater infiltration systems provide both dispersal and treatment of the applied wastewater. Wastewater is transported from the infiltration system through three zones.

Two of these zones, the infiltration zone and vadose zone, act as fixed-film bioreactors. The infiltration zone, which is only a few centimeters thick, is the most biologically active zone and is often referred to as the "biomat."

Carbonaceous material in the wastewater is quickly degraded in this zone, and nitrification occurs immediately below this zone if sufficient oxygen is present. Free or combined forms of oxygen in the soil must satisfy the oxygen demand generated by the microorganisms degrading the materials.

If sufficient oxygen is not present, the metabolic processes of the microorganisms can be reduced or halted and both treatment and infiltration of the wastewater will be adversely affected (Otis, 1985).

The vadose (unsaturated) zone provides a significant pathway for oxygen diffusion to re-aerate the infiltration zone (Otis, 1997; Siegrist et al., 1986). In addition, it is the zone where most sorption reactions occur because the negative moisture potential in the unsaturated zone causes percolating water to flow into the finer pores of the soil, resulting in greater contact with the soil surfaces. Finally, much of the phosphorus and pathogen removal occurs in this zone (Robertson and Harman, 1999; Robertson et al., 1998; Rose et al., 1999; Yates and Yates, 1988).

### **Specifically, this is how a typical Conventional Septic System works:**

1. All water runs out of your house from one main drainage pipe into a septic tank.
2. The septic tank is a buried, water-tight container usually made of concrete, fiberglass, or polyethylene. Its job is to hold the wastewater long enough to allow solids to settle down to the bottom forming sludge, while the oil and grease floats to the top as scum.
3. Compartments and a T-shaped outlet prevent the sludge and scum from leaving the tank and traveling into the drainfield area.
4. The liquid wastewater (effluent) then exits the tank into the drainfield.
5. The drainfield is a shallow, covered, excavation made in unsaturated soil. Pretreated wastewater is discharged through piping onto porous surfaces that allow wastewater to filter through the soil. The soil accepts, treats, and disperses wastewater as it percolates through the soil, ultimately discharging to groundwater.

If the drainfield is overloaded with too much liquid, it can flood, causing sewage to flow to the ground surface or create backups in toilets and sinks.

6. Finally, the wastewater percolates into the soil, naturally removing harmful coliform bacteria, viruses and nutrients. Coliform bacteria is a group of bacteria predominantly inhabiting the intestines of humans or other warm-blooded animals. It is an indicator of human fecal contamination.

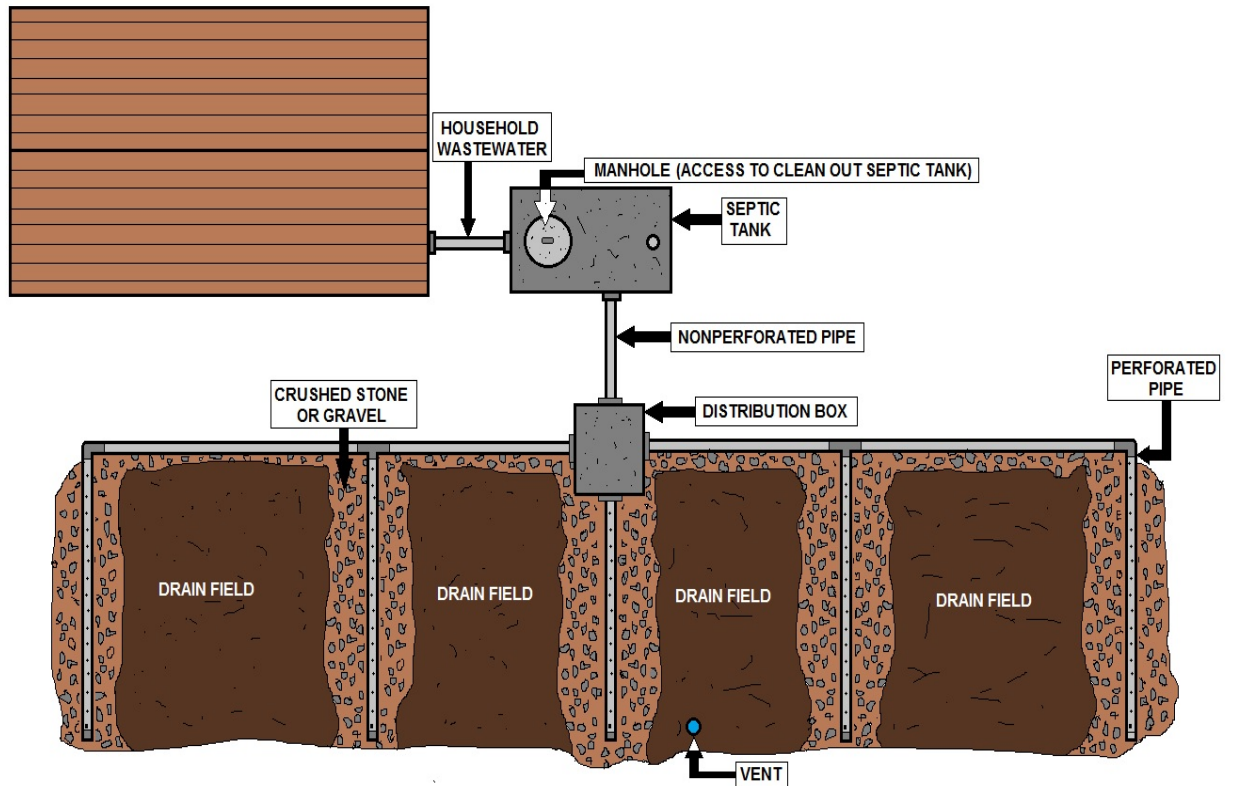

**TYPICAL DOMESTIC SEPTIC TANK SYSTEM**



## Septic Pretreatment Components

Pretreatment components remove many of the contaminants from the wastewater to prepare the effluent for final treatment and dispersal into the environment. The level of treatment is selected to match the receiving environment and the intended use. The quantity of contaminants is reduced to a level the soil can accept and treat. Many options exist for treatment prior to release into the receiving environment. Wastewater pretreatment components include septic tanks, trash tanks, and processing tanks, while aerobic treatment units, media filters, and constructed wetlands are considered advanced pretreatment components.

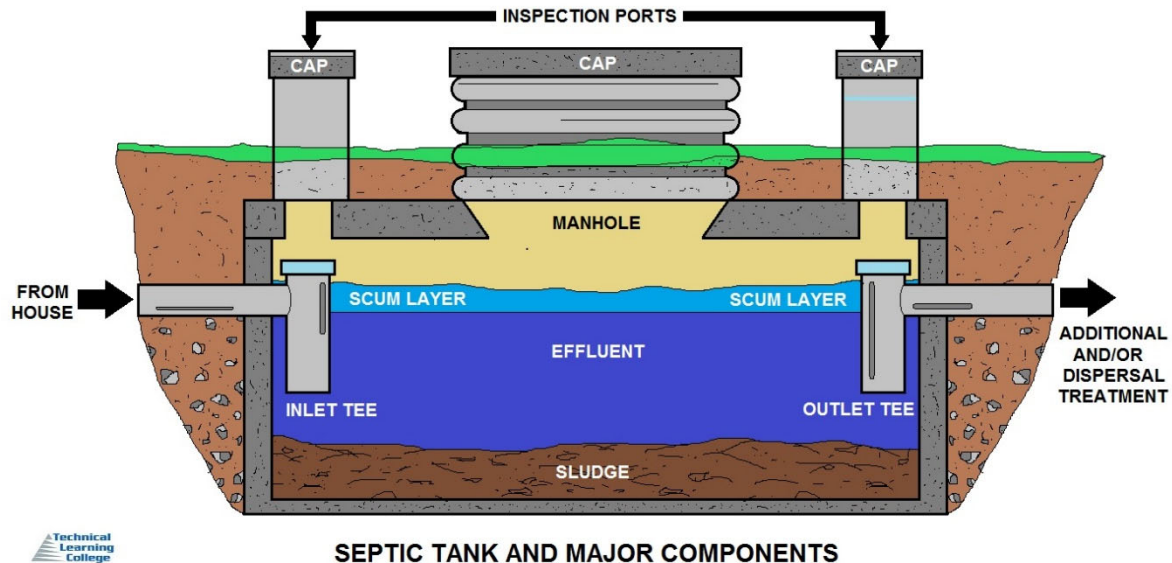

### Components

- Septic Tank
- Trash Tank
- Processing Tank
- Effluent Screen
- Recirculation Tank
- Final Treatment and Dispersal

Final treatment and dispersal components provide the final removal of contaminants and distribute the effluent for dispersal back into the environment. Several options are available for distributing wastewater in soil. Gravity flow systems are the most widely used dispersal systems. These systems will continue to be used in areas where the soil separation distances can be met, primarily because they are the least expensive alternative and require the least amount of operation and maintenance.

Pressurized distribution methods overcome a variety of site limitations. Low pressure, subsurface drip, and spray distribution systems are designed to function in difficult areas. These systems are pressurized, which assists in providing even distribution of wastewater. These technologies also facilitate reuse of wastewater in the landscape. These advantages, however, increase the operation and maintenance requirements.

## Methods

- Soil Adsorption Field
- Conventional Drainfield System
- Gravel-less Pipe
- Leaching Chamber
- Mound System
- Low-Pressure Drainfield (LPD)
- Low-Pressure Pipe (LPP)
- Shallow Narrow Drainfield
- Spray Distribution
- Drip Distribution
- Evapotranspiration Bed (ET)
- Media Filter as Drainfield Option
- Bottomless Sand Filter
- Bottomless Peat Filter

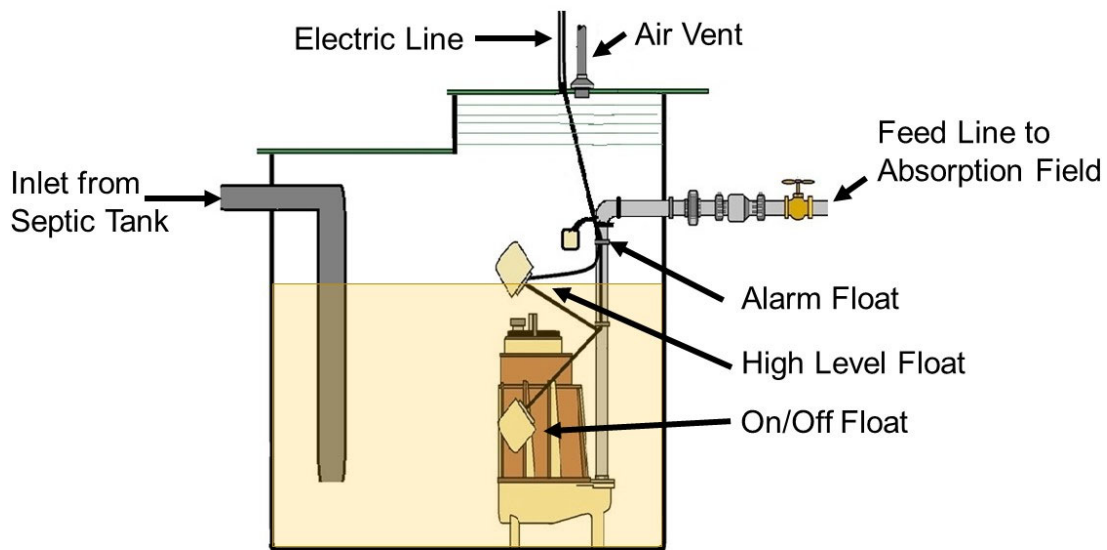

**GENERAL PUMPING TANK DIAGRAM**

## Elevated (Mound or At-Grade) Systems

This system type includes a septic tank or prefabricated treatment unit to provide primary (and sometimes secondary) treatment prior to discharging the effluent to a modified drainfield.

Effluent flows from the tank or treatment unit to a pump tank and periodically dosed to the modified dispersal area, which is typically constructed of a layer of clean, uniformly graded sand on a plowed or roughened natural soil surface.

The tank effluent is uniformly dosed onto the infiltrative surface within the mound, which may be 1-4 ft. above the natural grade. Sand within the mound compensates for shallow unsaturated soil conditions below the natural grade.

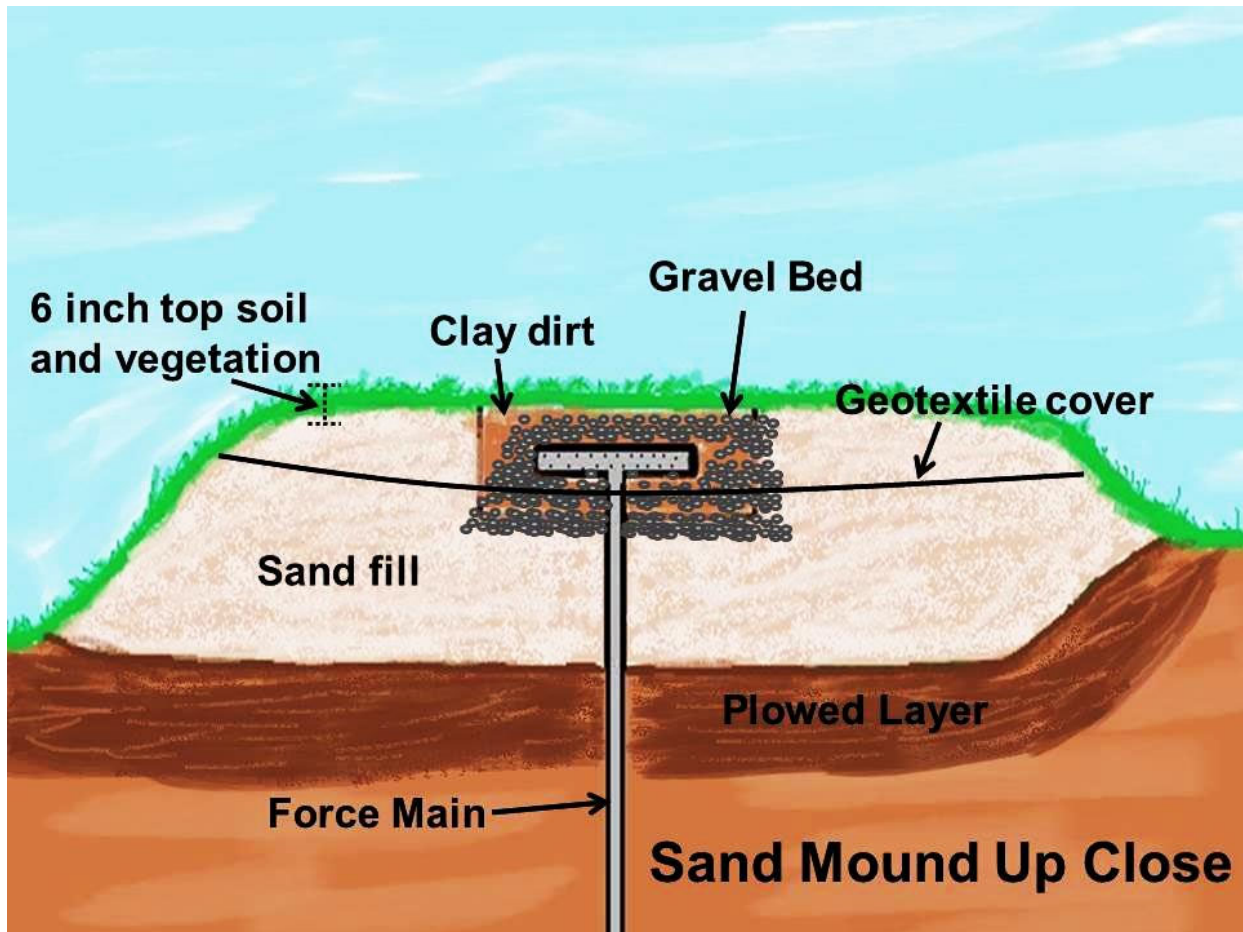

### Mound Systems

Mound systems are appropriate for areas with a high water table or shallow, fractured bedrock. After treatment through the sand, the effluent percolates directly into the soil under the mound. At-grade systems feature effluent dispersal piping placed at natural grade, with the mound consisting mostly of cover soil for the piping. The mound should have inspection ports, so wastewater distribution across the infiltration area can be monitored.

Distribution lines should have cleanouts so they can be flushed at least twice a year. Costs for mound systems range from \$12,000 to \$45,000. The cost is mostly related to the delivered cost of the mound materials and local labor costs. Operation and maintenance costs average \$300-\$1,500 per year.

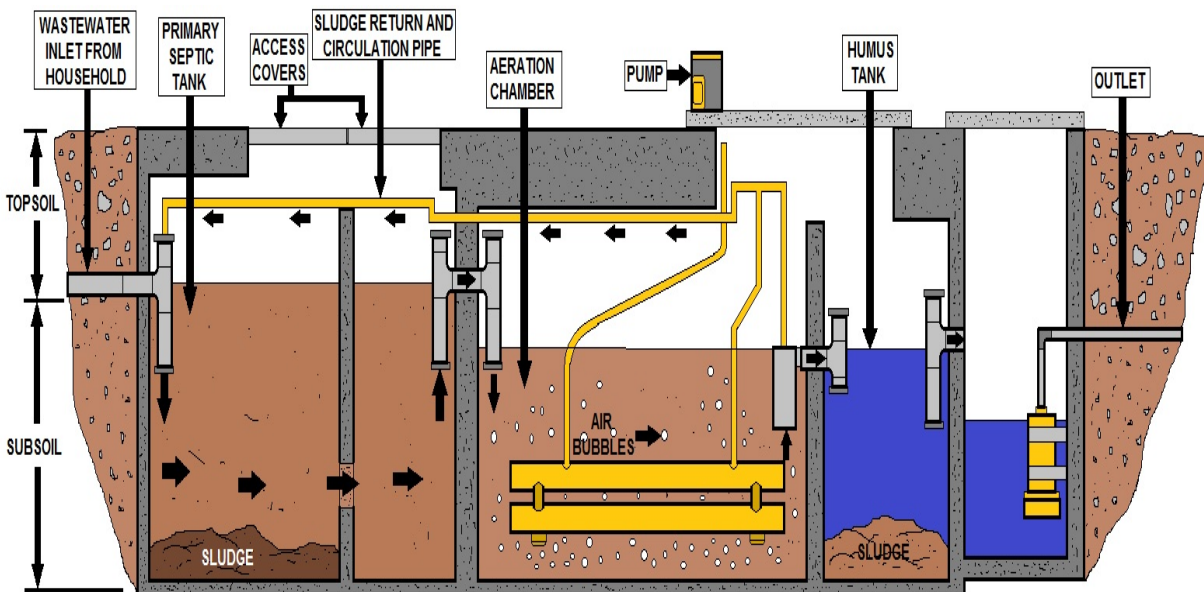
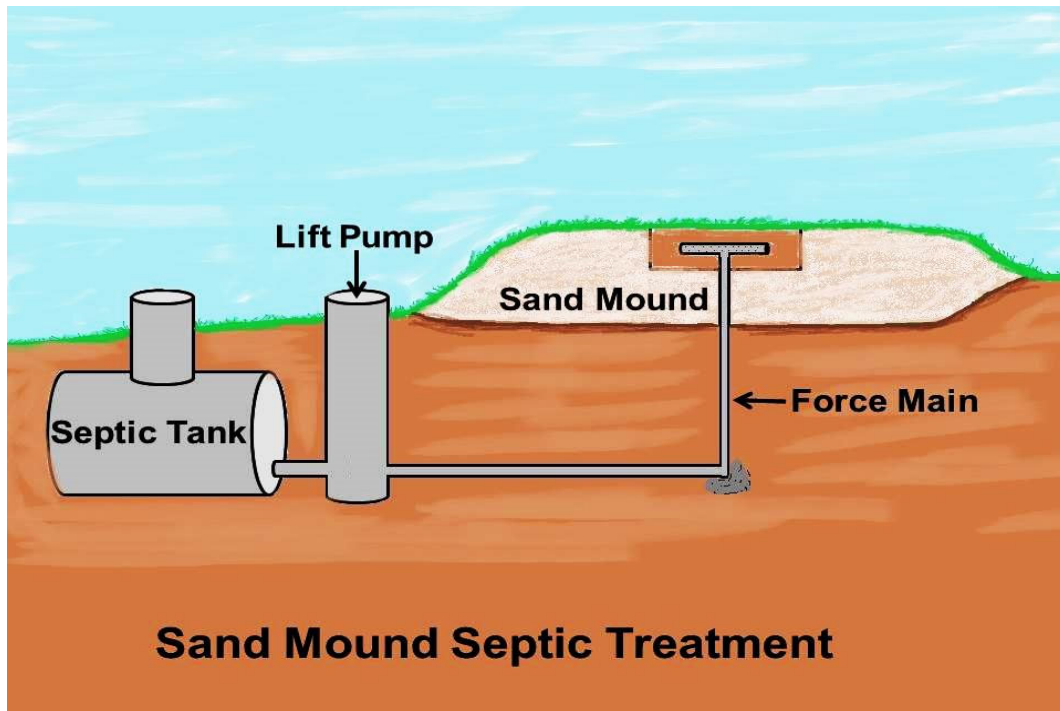

**SEQUENTIAL BATCH REACTOR (SBR) SYSTEM**

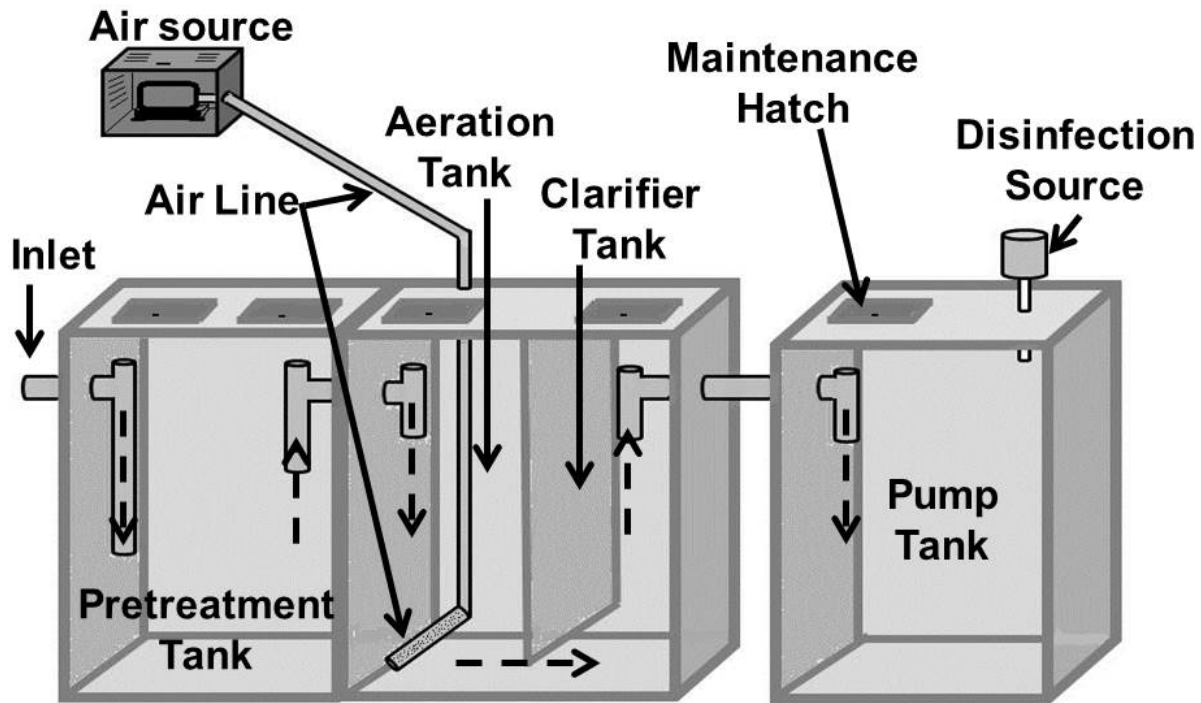

**AEROBIC WASTEWATER TREATMENT SYSTEM DIAGRAM**

### **Aerobic Treatment Units**

Aerobic treatment units (ATUs) consist of prefabricated units featuring consecutive or compartmentalized tanks, pumps, blowers, and internal piping, and are designed to treat wastewater via suspended or attached growth decomposition in an oxygen rich environment.

When oxygen is supplied, the rate of microbial activity and related treatment processes accelerates. Three processes are involved in most aerobic systems: physical separation (mostly settling), aerobic treatment (aeration and mixing), and clarification (final settling).

These processes may be in separate tanks, compartments of a single tank, or other configurations. ATUs vary in design and can consist of simple activated sludge variations, sequencing batch reactors, trickling filters, and combinations of two or more of these unit processes.

ATU systems require permanent, regularly scheduled inspections and maintenance attention. The National Sanitation Foundation has a certification program for aerobic treatment units based on testing over a range of operating conditions.

An activated sludge ATU, where oxygen is added by injecting adding air into the wastewater, can range between \$10,000 and \$20,000 installed with maintenance costs averaging \$1,000 and \$2,500 per year.

## Fixed-Activated Sludge Treatment

ATUs cost slightly more than an activated sludge unit; however, maintenance costs are reduced by half. The cost of Sequencing Batch Reactors, which perform all functions in a single tank, can range \$10,500 to \$30,000 installed, with yearly maintenance costs at \$1,500 to \$2,500.

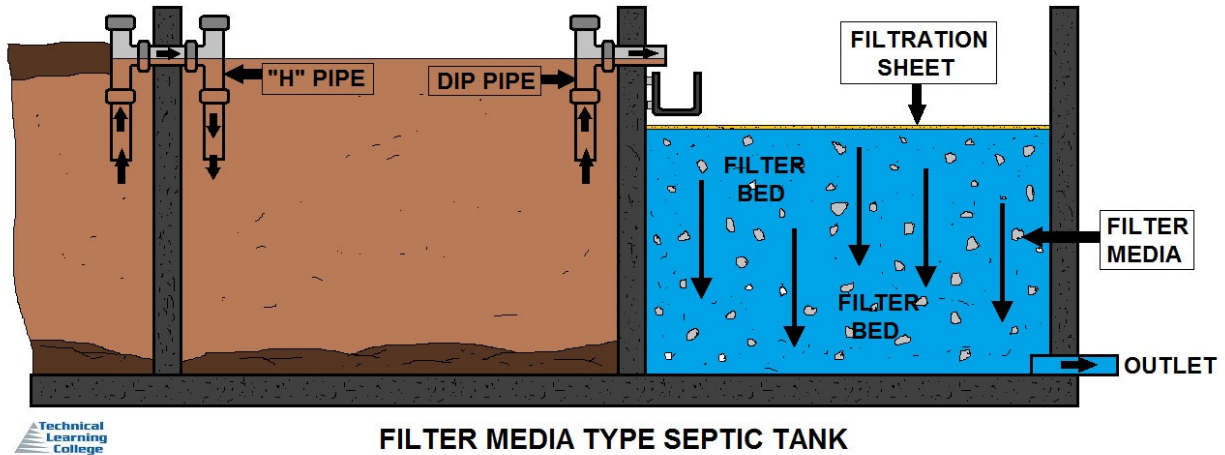

## Media Filters

Septic tank effluent can be applied to a layer of sand or gravel, a tank containing peat or plastic media, or compartments of hanging textile or other material to improve oxygen access and enhance biochemical treatment processes. A number of these so-called “media filters” are available to treat wastewater.

Sand is the most commonly used media, but clean gravel, crushed glass, textile strips, peat, and tire crumbs are also used, depending on site restrictions and state/local regulations. In single-pass or intermittent filter (ISF) design, septic tank effluent is pump-dosed uniformly onto the media at regular intervals 12 to 48 times per day.

As the effluent trickles through the media, suspended and some colloidal particles are filtered, and bacteria growing on the media aerobically treat organic wastewater. Effluent that percolates through the media bed is discharged to the soil dispersal field. Intermittent filters include higher installed costs (\$7,000 to \$12,000) and have some potential for odors if septic tank effluent is the influent stream.

Operation and maintenance costs run from \$175 to \$550 per year. Recirculating sand filters (RSF) return two-thirds or more of the filter percolate to the pump dosing chamber, greatly improving nitrogen removal (e.g., up to 50 percent or more, depending on influent nitrogen levels and other factors).

Effluent quality from the RSF and ISF are typically less than 10 mg/L of BOD and TSS, however, the facility size for an RSF is less, and it lacks the odor potential of the ISF. A recirculating filter system costs \$10,000 to \$15,000 installed.

Operation and maintenance costs range from \$350 to \$1,500 per year. In addition to maintenance of the pump and controls, dosing lines must be flushed and the pressure on each line checked at 6-month intervals.

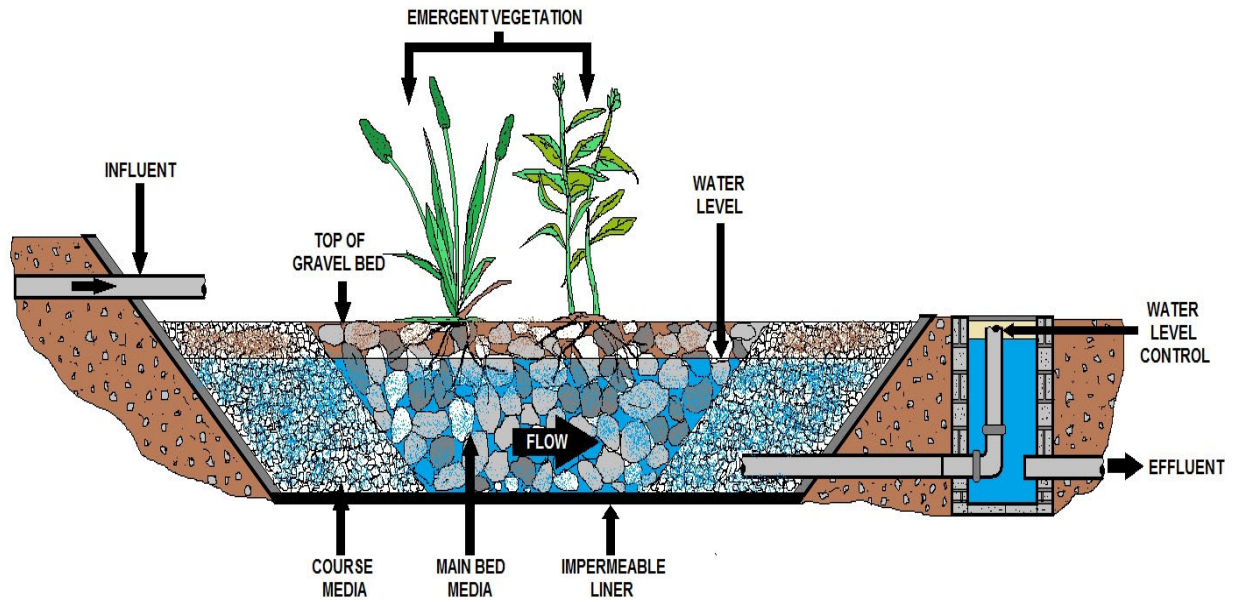

**VEGETATIVE SUBMERGED BED (VSB)**

## Submerged-Flow Wetland or Vegetative Submerged-Bed (VSB)

Vegetative submerged beds are also called submerged-flow wetlands. This system type treats septic tank effluent by horizontal flow through a lined bed of unmulched gravel planted with wetland species. The plants fill in spaces between the rocks and provide aesthetic appeal. Wetland systems are extremely passive and require little management in producing a good quality effluent (typically BOD and TSS of less than 30 mg/L).

The treatment environment in the system is mostly anaerobic, with some aerobic microsites on plant roots and near surface areas. Effluent is further treated when discharged to unsaturated soil following flow through the wetland cell(s).

Septic tanks with subsurface flow gravel bed wetlands have been used successfully in many areas including Texas, Louisiana, Arizona, Indiana, and Kentucky. Constructed wetlands can have a relatively low construction cost in areas where media and land is readily available.

Properly designed and constructed systems do not require chemical additions or mechanical equipment.

Maintenance is important to prevent clogging the rock bed and influent and effluent structures. The average cost of a VSB system can range from \$7,000 to \$25,000 installed. Operation and maintenance costs are generally less than \$500 per year.

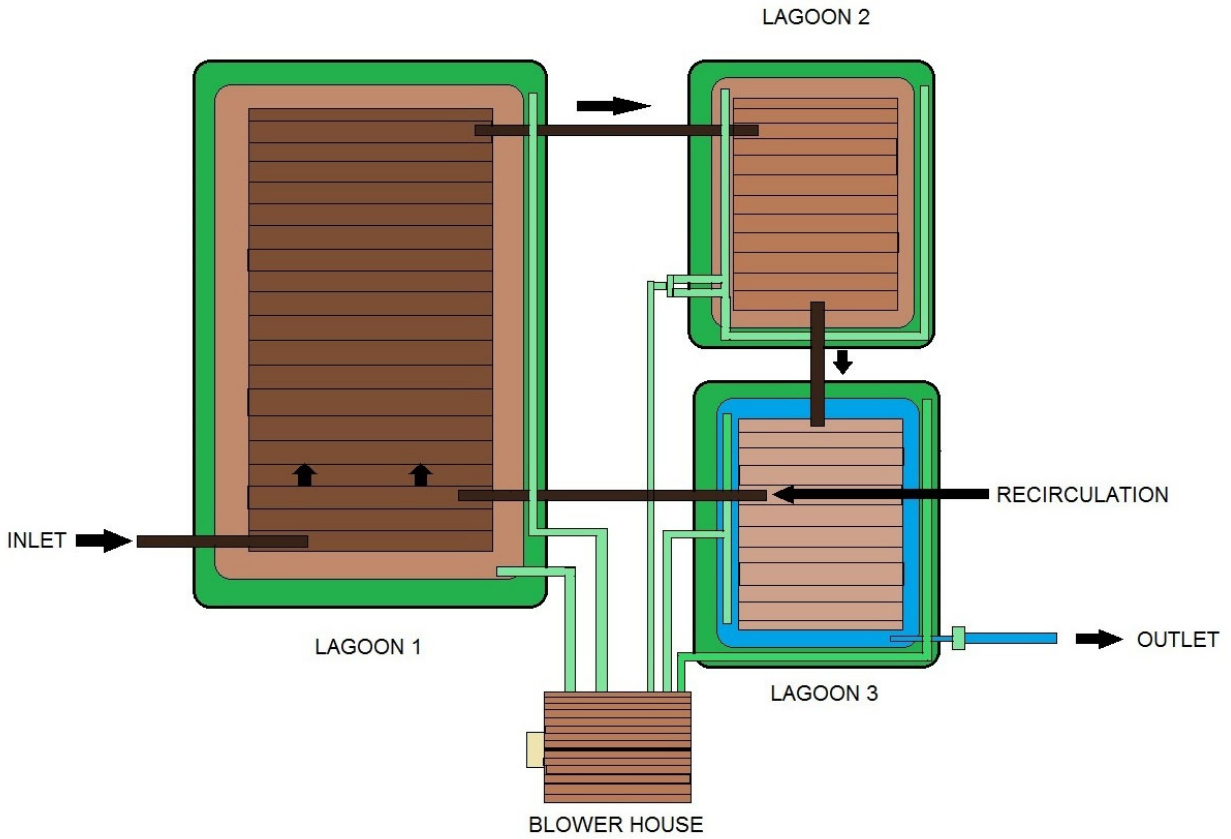

## ADS LAGOON SYSTEM

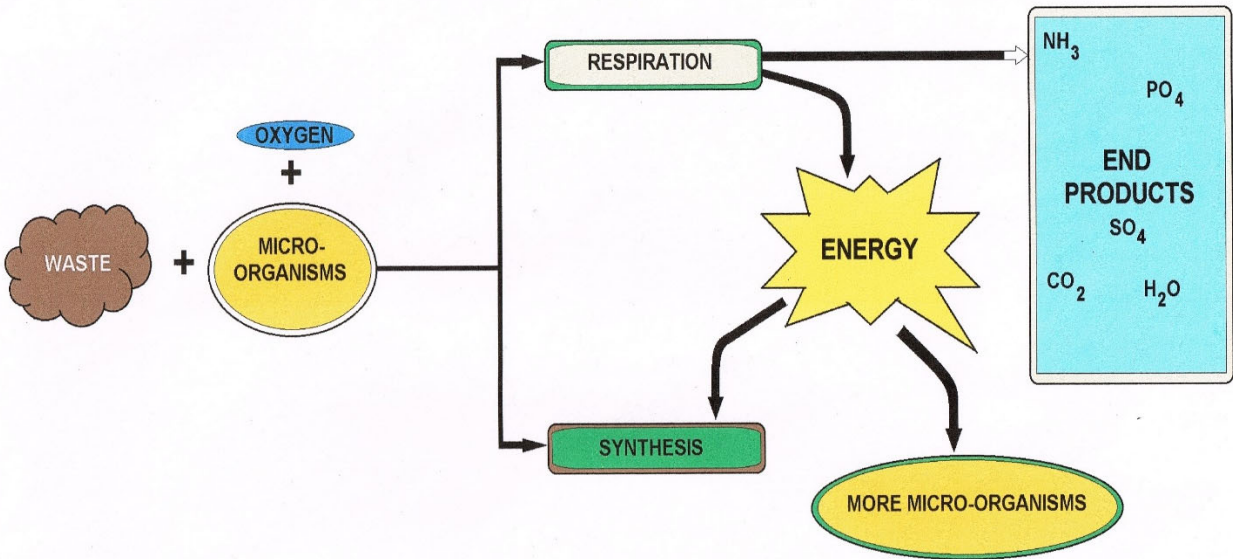



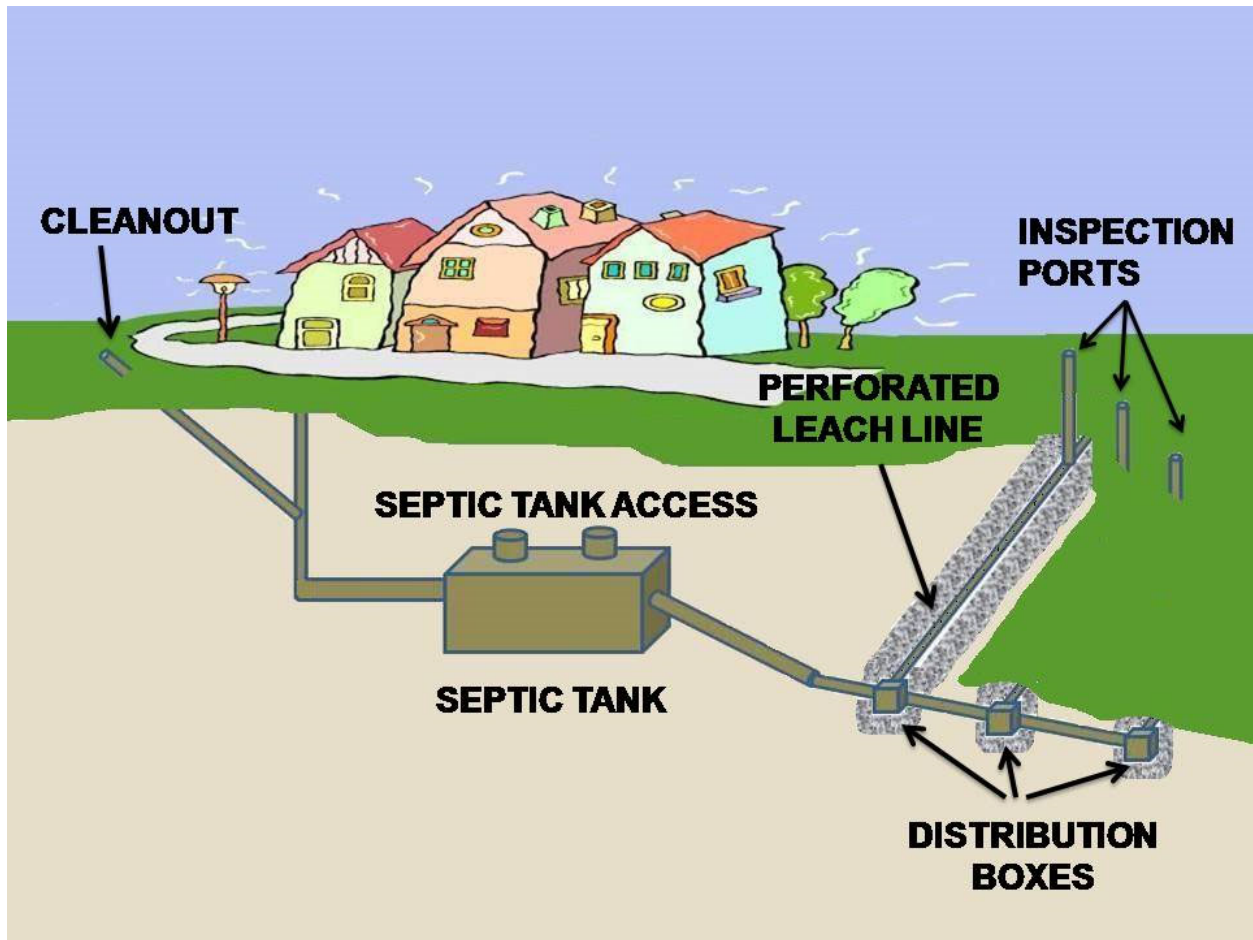

## Cluster System Applications

A cluster system is designed to collect wastewater from two to several hundred homes. The Cluster Wastewater Systems Planning Handbook lists a number of potential wastewater collection technologies for small and large cluster systems, including: grinder pump systems, which transport all sewage; effluent sewers, such as the septic tank effluent pump (STEP); the septic tank effluent gravity (STEG) collection system; and vacuum systems.

Treatment facilities serving clustered buildings may range from a communal septic tank and soil dispersal system to a more advanced treatment system.

Advanced systems may facilitate local reuse of the treated effluent for toilet flushing, irrigation, industrial purposes, or to replenish aquifers. Cluster systems must be managed by an entity with the technical, financial, and managerial capacity to effectively and efficiently handle operation, maintenance, customer billing, repair/replacement, and other tasks.

An appropriate method of treatment is provided prior to final effluent distribution/disposition using a suitable subsurface or surface effluent dispersal method. The method of treatment and final dispersal of effluent are based on local conditions and treatment needs, and applicable regulatory requirements.

### **Advantages Cluster systems have a number of advantages:**

- Cost
- Flexibility in land use
- Maintenance
- Environmental protection Cost

Conventional sewer and treatment systems in can cost \$20,000 or more per household (2000 prices), and can result in monthly sewage bills of over \$100. The design and construction of the sewage collection system is often responsible for two-thirds or more of the cost. Much of this is due to the large-diameter gravity sewers, which must be laid on grade and can require very deep excavations or a number of lift stations.

Small-diameter plastic pipes used in alternative systems are less expensive and easier to install than conventional sewer pipes. Pressurized sewers do not rely on gravity to operate, so they can be buried at shallow depths, just below the frost line, and follow the natural contours of the land, saving on excavation costs.

### **Flexibility in Land Use**

County planning agencies sometimes cite the soil and site limitations of traditional onsite systems as the justification for halting development in unsewered areas and to defend land-use plans. Alternative onsite technologies have the potential to allow land-use decisions to be determined more by issues such as roads, schools, hospitals, and other important criteria.

Cluster wastewater systems may permit smaller lot sizes and provide planners with a tool to better preserve the green areas and rural character of small communities. These features are frequently lost when large, gravity sewers are installed and high-density development follows, or if large lot sizes are required for individual onsite sewage disposal systems.

### **Maintenance**

Complex sewage treatment processes require expertise often not found in rural locations. When workers acquire this expertise through training and experience, they often have an opportunity for higher salaries in nearby cities. Therefore, treatment systems that require larger land areas, but less complex operation and maintenance (O&M) are often attractive for small communities. Such systems minimize the need for process understanding and rely more on the mechanical aptitude of an O&M staff, which is more often available in rural settings.

### **Environmental Protection**

Many small communities with centralized sewage treatment systems are having difficulties in meeting required discharge limits. According to the EPA, sewer small communities with discharge of treated wastewater represented over 90 percent of non-compliance violations in 1999. Since many of these small community systems discharge to high quality, low flow streams, local environmental impacts can be disproportionately high. Non-discharging, decentralized wastewater treatment systems can provide an environmentally sound alternative for these communities.

### **Disadvantages**

The primary disadvantage of cluster systems has to do with the amount of operation and maintenance needed. While usually not complicated, alternative sewers have components that conventional sewers do not have, such as septic tanks that need to be inspected and pumped and mechanical parts and controls that use electricity.

These require more frequent and regular maintenance than conventional sewers. They also are located on site, requiring workers to travel to individual homes or businesses. This may, however, be more than offset by higher operational costs at more complex central treatment facilities.

Clusters require a somewhat complex organizational structure in order to make community decisions such as fee collection and continuing education of homeowners about wastewater issues.

### **Homeowner Cooperation**

Homeowner cooperation is much more important than with municipal systems since smaller systems are less resilient and less tolerant of periodic large flows or larger than normal loadings of household chemicals than in large systems, where these peaks are averaged out over a very large user base.

Other disadvantages with alternative sewers include disruptions in service due to mechanical breakdowns and power outages. In addition, systems may be poorly designed, installed, or overpriced if engineers or contractors have little experience with alternative technology. Poor design and installation of alternative sewers can result in higher than expected O&M costs.

Managing  
With traditional onsite systems, maintenance is left up to the homeowner who typically pays little attention to the system until it begins to fail. Innovative systems require more homeowner awareness as well as regular maintenance procedures.

Preventative maintenance is important with this technology because an overloaded septic tank or broken pump at one connection can potentially affect other parts of the system.

Depending on the size of the system, communities may need a fulltime maintenance employee or staff to ensure that the system is being properly operated and maintained and to handle emergencies. There are several models for providing maintenance for cluster systems.

All systems require that workers have access to the user's property to inspect septic tanks and effluent baffles or filters on a routine basis and to pump tanks as needed. Regular maintenance is also necessary to ensure proper performance of the pretreatment and final disposal.

Remote monitoring may have a place in managing decentralized onsite systems, and small community systems that are too small to have onsite operators present at all times.

Advanced onsite monitoring systems typically use "control boxes" that turn electric pumps on and off, monitor septic tank levels, and sound an alarm when an unusual condition occurs. The alarm connects to a panel in the house. The homeowner must then contact a repairman.

Remote sensing could also be used to send a signal from the home directly to a central monitoring office. In more complex systems, the communication can even be interactive so that pump dosing frequencies could be changed, along with other system controls, from a remote base.



## Pressure and Drip Soil Dispersal System Operation and Inspection

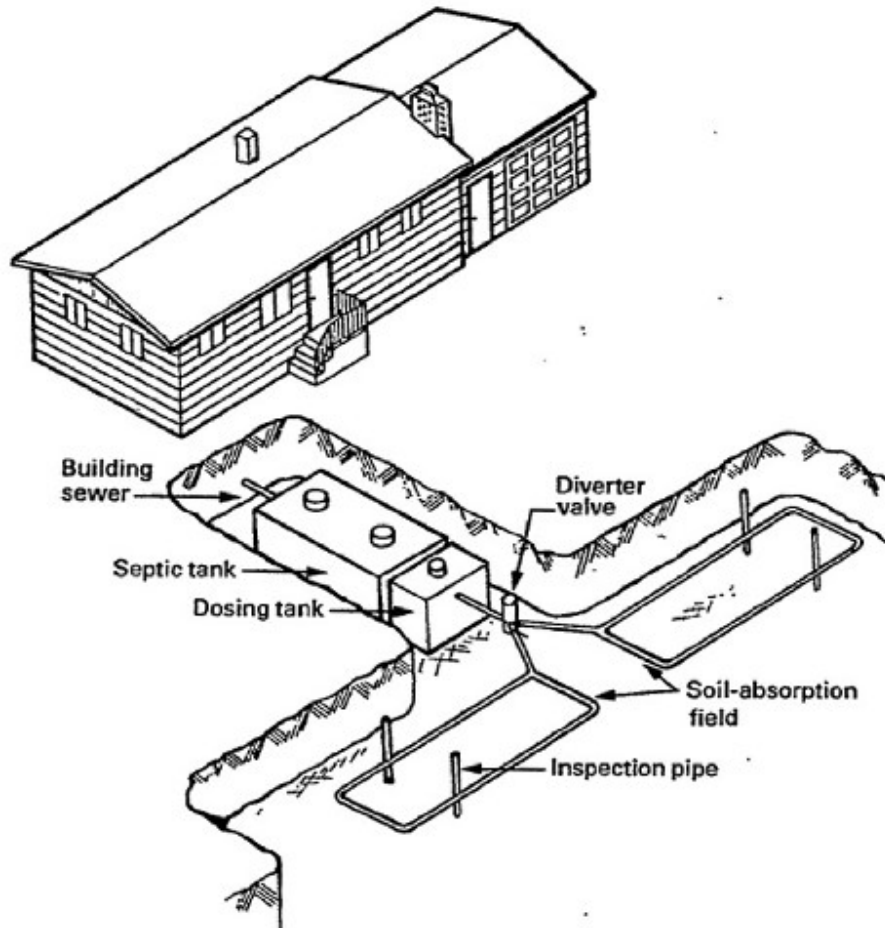

**Pressure and Drip Soil Dispersal System**

The diagram above (edited courtesy USDA) shows a generic septic effluent dosing system, combining a septic tank, a dosing tank, a diverter valve, and two septic effluent dispersal loops through a soil absorption field.

Septic effluent is distributed to a system final treatment and disposal using either gravity methods (which depend on terrain slope - see Gravity-Siphon Dosing Systems or pressure methods – Pressure Dosing Systems (which use a pump to move effluent to its destination treatment and disposal area). Effluent may be distributed for final soil absorption by several methods listed here:

- Single Effluent Line: A 4" perforated PVC pipe receives effluent by gravity from the septic tank. The pipe is buried in a gravel trench and may be run in a straight line or a loop.
- Distribution Box/Network of Lines A distribution box receives effluent by gravity from the septic tank and routes it to a network of perforated pipes. The network is made of multiple independent trenches which maybe on a flat or sloped site.
- Serial relief line: multiple, serially connected trenches are built on a sloping site and used serially.
- Drop box: multiple independent trenches are built on a sloping site, connected from drop boxes.

The purpose of septic effluent "dosing" systems is to place septic effluent in the absorption system or drainfield at intervals rather than continuously. In effect, the effluent dosing chamber forms a "buffer" which receives and stores septic effluent flowing (or being pumped) out of the septic tank until a desired dosing quantity is reached.

Then the effluent is dispersed to the absorption system in one "dose." By distributing effluent at intervals rather than on a more nearly continuous or irregular basis the absorption system can "rest" between cycles, extending its life and possibly increasing its ultimate effluent treatment and disposal capability. Not only does the rest interval permit the absorption system more time to dispose of its effluent, also the exposure of the system to air between doses can reduce the rate of clogging of the drainfield.

Wastewater effluent is distributed for final treatment over time either by uncontrolled, or controlled methods.

### **Uncontrolled Septic Effluent Flow**

A conventional gravity septic system and drainfield is "uncontrolled". When waste enters the septic tank, it forces the same volume of effluent out of the tank and into the leach field. Some experts call this a continuous or trickling septic system. Conventional septic tank and drainfields use this approach. The timing of effluent movement or "trickle" into the absorption field is based simply on when people are using the building plumbing and thus based simply on when wastewater flows out of the building into the septic tank.

### **Controlled Septic Effluent Flow**

Controlled systems effluent is sent to the final treatment and disposal system such as an absorption field under either mechanical control such as a tipping or siphon system or under pump control, such as by use of a dosing system which makes use of a gravity dosing method or a pressure dosing method such as septic effluent pressure manifold, rigid pipe distribution, or a septic effluent drip network. In some large wastewater treatment systems with a significant if not uniformly continuous inflow, outflow of the system may be continuous in some designs. But many systems use an intermittent effluent dosing method which operates by a pump controlled perhaps by a float in an effluent receiving chamber, or by a siphoning or tipping bucket mechanical system (gravity systems).

### **Pressure-dosed Drainfield Septic Systems**

Pressure-dosed Drainfield Septic Systems use a separate effluent pumping chamber and an effluent pump. The effluent pumping station is located downstream from the septic tank and is used to move septic effluent into a pressure-fed network of distribution pipes. In some designs the effluent is pumped to move it up to the absorption field where it then moves by gravity. Other systems pressurize the entire piping network.

Pressure dosing is used in a variety of disposal field designs including mounds and sand beds, and have the advantage of being able to distribute effluent uniformly throughout the absorption system, and the disadvantage of added system cost and complexity, along with the requirement for electricity for system operation.

An alternative but possibly less long-term reliable version of a drainfield dosing system that does not require electricity is the siphon system. The sketch shows a generic pumping station of the type used with many pressure dosing systems, source US EPA and Purdue University.

Source for the following is New York State regulations on wastewater treatment and design for individual household septic systems (Note b below) and from the U.S. EPA Wastewater Manual.

(1) **These methods permit the rapid distribution of effluent** throughout the absorption system followed by a rest period during which no effluent enters the system. The maximum length of absorption lines used in conjunction with these methods shall be 100 feet.

(i) **Pressure distribution utilizes a sewage effluent pump** to move the effluent through the pipe network and into the soil. The volume discharged in each cycle will exceed the volume available in the pipe network and will be discharged from the pipe under pressure.

(ii) **Dosing involves the use of a pump or siphon for pressure dosing septic systems** to move the effluent into the pipe network. Discharge from the pipe is by gravity. The volume of effluent in each dose should be 75% to 85% of the volume available in the pipe network.

(2) **Dosing or pressure distribution is recommended for all septic systems** as it promotes better treatment of wastewater and system longevity.

(3) **In absorption fields, single pressure dosing units are required when** the total trench length exceeds 500 feet. Alternate dosing units are required when the length exceeds 1,000 feet.

(4) **The use of manually operated siphons or pumps for pressure dosing septic systems is not acceptable.**

(5) **Pipe used in pressure dosing septic systems distribution shall** have a minimum diameter of 1.5 inches and a maximum diameter of three inches. Pipe for siphon dosing is sized to conform with the volume of the dose and can range from three to six inches in diameter based upon the volume of each dose. The ends of all pipes shall be capped.

(6) **Only pumps for pressure dosing septic systems** designated by the manufacturer for use as sewage effluent pumps shall be used.

(7) **Pump chambers for pressure dosing septic systems shall be equipped with an alarm** to indicate malfunction. Siphon dosing systems normally include an overflow to the distribution laterals. Pressure distribution systems shall not be equipped with an overflow.

(8) **Pump chambers for pressure dosing septic systems shall be sized** to provide a minimum of one day's design flow storage above the alarm level. Siphon chambers shall have a minimum total storage of one day's design flow below the overflow pipe.

Footnote (b): The preceding example septic pressure dosing system design and descriptive data for septic effluent pressure distribution and pressure dosing systems is from Appendix 75-A to Public Health Law, 201(1)(1) New York State Wastewater Treatment Standards - Individual Household Septic Systems, Wastewater Treatment Design and Regulation Section, specifically chapter 75-A.7 Distribution lines, distribution boxes, gravity flow, pressure distribution, dosing, siphons





## Advanced (Tertiary) Systems Introduction

Alternative systems use pumps or gravity to help septic tank effluent trickle through sand, organic matter (e.g., peat and sawdust), constructed wetlands, or other media to remove or neutralize pollutants like disease-causing pathogens, nitrogen, phosphorus, and other contaminants. Some alternative systems are designed to evaporate wastewater or disinfect it before it is discharged to the soil.

Treatment system components designed to pretreat septic tank effluent before discharge to the soil dispersal field are often called alternative, enhanced, or advanced systems. Advanced systems can be designed and built onsite or can consist of prefabricated units designed to overcome some site and soil limitations including:

When the aerated (unsaturated) soil depth below the infiltrative surface in the drainfield is less than the minimum required, advanced treatment processes or components (e.g., fixed film treatment units) can be added to increase pollutant removal prior to soil discharge.

In environmentally sensitive areas, advanced systems can be used to meet effluent standards for oxygen-demanding wastes, bacteria, nitrogen, and phosphorus.

If a soil dispersal area malfunctions hydraulically due to a buildup of the biomat (inorganic, organic, and/or bacterial slime) at the infiltrative surface, it may be restored, and treatment may be enhanced, by improving soil oxidation through timed dosing of septic tank effluent to the dispersal field. The dose/rest cycle allows the soil to drain between doses, improving soil oxygen transfer.

Wastewater with high organic strength (e.g., from a restaurant) can employ advanced treatment units/processes to improve aeration, biological decomposition, and treatment of organic wastes. (Note: High concentrations of fats, oils, and greases should be removed through housekeeping practices and use of a grease trap tank.)

Advanced systems that provide timed dosing of septic tank or treatment unit effluent to the soil can sometimes be used where soil infiltration areas are limited, except in cases of high-clay content soils.

Advanced systems that employ pressure drip dispersal of the effluent can reduce bacteria and nutrient loading to groundwater by applying wastewater high in the soil profile, improving bacteria predation and uptake of nutrients by plants and providing a carbon source for denitrification.

All treatment systems require management, but advanced systems, due to their use of pumps, switches, and other electromechanical components, especially need regular operation and maintenance attention.

Permanent maintenance contracts with qualified service providers should be required by state or county code for systems with these components.

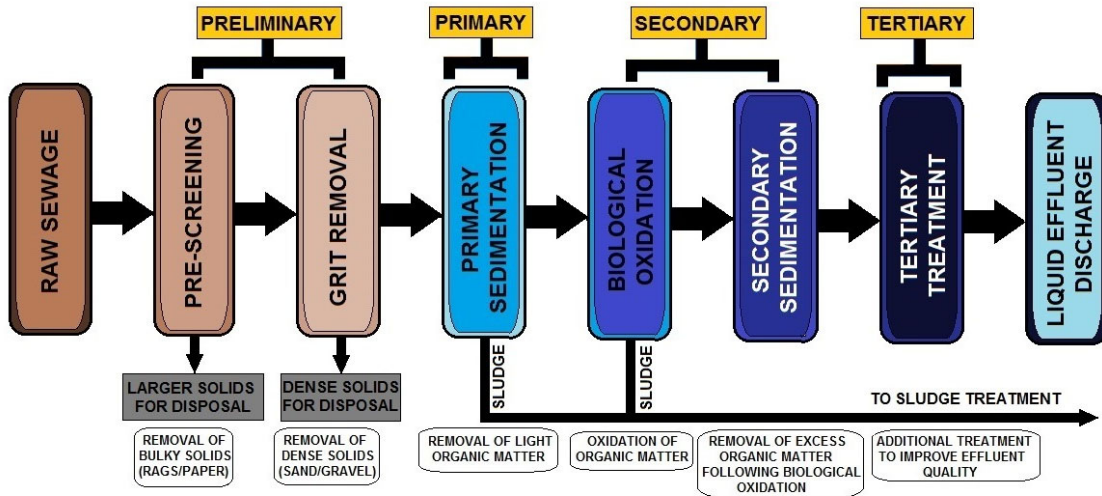

## INTRODUCTION OF WASTEWATER TREATMENT METHODS AND STEPS

TREATMENT METHODS	REMOVAL CAPABILITIES
FILTRATION AIR / STEAM STRIPPING	SUSPENDED SOLID PARTICLES DISSOLVED AMMONIA VOLATILE ORGANIC COMPOUNDS (VOC's)
ADSORPTION	DISSOLVED ORGANICS, TO INCLUDE VOC's COLOURING ODORIFEROUS COMPOUNDS
BIOLOGICAL PROCESSES	NITROGENOUS & PHOSPHOROUS COMPOUNDS
MEMBRANE SEPARATION PROCESS SUCH AS MICROFILTRATION, ULTRA FILTRATION, NANOFILTRATION & REVERSE OSMOSIS (RO)	DISSOLVED ORGANICS AND INORGANICS
ION-EXCHANGE PROCESS	DISSOLVED ANIONS AND CATIONS
PRECIPITATION	HEAVY METAL IONS AND OTHER IONIC SUBSTANCES
OXIDATION - REDUCTION	ORGANICS & SOME INORGANICS
DISINFECTION	MICRO - ORGANISMS TO INCLUDE VIRUS



## TERTIARY METHODS AND THEIR EFFECTIVENESS IN TREATMENT

# Advanced Onsite Wastewater Treatment Systems and Components

## Sand Filters

A packed-bed filter of sand or other granular materials used to provide advanced secondary treatment of septic tank effluent. Sand/media filters consist of a lined (e.g., impervious PVC liner on sand bedding) excavation or structure filled with uniform washed sand that is placed over an under-drain system.

The wastewater is dosed onto the surface of the sand through a distribution network and allowed to percolate through the sand to the under-drain system, which collects the filter effluent for further processing or discharge.

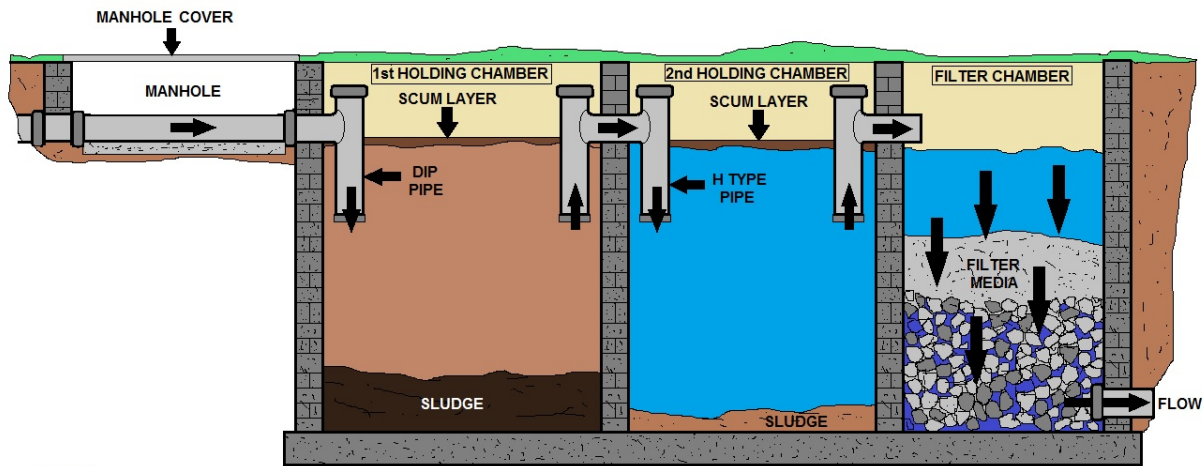

SEPTIC TANK WITH FILTER MEDIA

## Other Media Bio-filters

Packed-bed filters using other more porous materials, (e.g., peat, textile, or foam) to provide advanced secondary treatment of septic tank effluent.

## Constructed Wetlands

An OWTS that incorporates an aquatic treatment system consisting of one or more lined basins which may be filled with a medium and where wastewater undergoes some combination of physical, chemical, and/or biological treatment and evapotranspiration.

## Sand Mounds

An above ground treatment system that incorporates at least 12 inches of clean sand above the original soil surface and disperses the treated wastewater into the original soil.

## Low-Pressure Distribution Systems

An OWTS in which pressurized small diameter distribution lines are used for equal distribution of effluent within the final treatment and dispersal component. These systems include low-pressure pipe (LPP) distribution systems, as described in the Missouri Minimum Construction Standards, and other systems such as an otherwise conventional system with a pressurized distribution network.

### **Drip Irrigation Systems**

A subsurface soil dispersal system that distributes treated wastewater through drip irrigation lines.

### **Modified Shallow Placed Gravity Lateral Trenches**

Six to 12 inches deep in natural soil and other engineered distribution systems using fill soil material.

### **Suitable Soil**

Suitable soil is an effective treatment medium for sewage tank effluent because it contains a complex biological community. One tablespoon of soil can contain over one million microscopic organisms, including bacteria, protozoa, fungi, molds, and other creatures. The bacteria and other microorganisms in the soil treat the wastewater and purify it before it reaches groundwater. However, the wastewater must pass through the soil slowly enough to provide adequate contact time with microorganisms. To provide adequate time for treatment of septic tank effluent, it is necessary to have at least three feet of aerated or unsaturated soil and limit the loading of effluent.

Microorganisms in soil treat wastewater physically, chemically, and biologically before it reaches the groundwater, preventing pollution and public health hazards. Under some soil conditions, subsurface absorption systems may not accept the wastewater or may fail to properly treat the wastewater unless special modifications to system design are made.

Public health is a major concern because domestic wastewaters contain many substances that are undesirable and potentially harmful, such as pathogenic bacteria, infectious viruses, organic matter, toxic chemicals, pharmaceutical drugs (e.g. endocrine disruptors), and excess nutrients.

Soil microorganisms need the same basic conditions as humans do to live and grow: a place to live, food to eat, water, oxygen to breathe, suitable temperatures, and time to grow. Soil microorganisms attach themselves to soil particles using microbial slimes and use the oxygen and water that are present in the soil pores.

To protect the public as well as the environment, wastewater must be treated in a safe and effective manner. The first component in an individual sewage treatment system is usually a septic tank, which removes some organic material and total suspended solids (TSS).

TSS and organic material removal is very important because it prevents excessive clogging of the soil infiltrative surface.

### **Suitably Textured Soil**

Suitably-textured soil must be deep enough to allow adequate filtration and treatment of the effluent before it is released into the natural environment. Usually this release is into groundwater. It has been determined that three feet of aerated soil will provide sufficient treatment of septic tank effluent.

Therefore, a three-foot separation distance is required from the bottom of the dispersal media to a limiting soil condition such as groundwater or bedrock. This three-foot treatment zone provides sufficient detention time for final bacteria breakdown and sufficient distance for the filtration that is essential for the safe treatment of effluent BOD.

## Residuals (Septage) Sub-Section



### Septage

Septage is an odoriferous slurry (solids content of only 3 to 10 percent) of organic and inorganic material that typically contains high levels of grit, hair, nutrients, pathogenic microorganisms, oil, and grease.

Septage is defined as the entire contents of the septic tank- the scum, the sludge, and the partially clarified liquid that lies between them and also includes pumpings from aerobic treatment unit tanks, holding tanks, biological ("composting") toilets, chemical or vault toilets, and other systems that receive domestic wastewaters. Septage is controlled under the federal regulations at 40 CFR Part 503.

Septage also may harbor potentially toxic levels of metals and organic and inorganic chemicals. The exact composition of septage from a particular treatment system is highly dependent upon the type of facility and the activities and habits of its users. For example, oil and grease levels in septage from food service or processing facilities might be many times higher than oil and grease concentrations in septage from residences.

Campgrounds that have separate graywater treatment systems for showers will likely have much higher levels of solids in the septage from the blackwater (i.e., toilet waste) treatment system. Septage from portable toilets might have been treated with disinfectants, deodorizers, or other chemicals.

## Chemical and Physical Characteristics of Domestic Septage Table

Parameter	Concentration (mg/L)	
	Average	Range
Total solids	34,106	1,132- 130,475
Total volatile solids	23,100	353- 71,402
Total suspended solids	12,862	310- 93,378
Volatile suspended solids	9,027	95- 51,500
Biochemical oxygen demand	6,480	440- 78,600
Chemical oxygen demand	31,900	1,500- 703,000
Total Kjeldahl nitrogen	588	66- 1,060
Ammonia nitrogen	97	3-116
Total phosphorus	210	20-760
Alkalinity	970	522- 4,190
Grease	5,600	208- 23,368
pH	-	1.5-12.6

Source: USEPA, 1994.

## Typical Pollutants of Concern in Effluent from Onsite Wastewater Treatment Systems Table

Pollutant	Public health or water resource impacts
Pathogens	Parasites, bacteria, and viruses can cause communicable diseases through direct or indirect body contact or ingestion of contaminated water or shellfish. Pathogens can be transported for significant distances in ground water or surface waters.
Nitrogen	Nitrogen is an aquatic plant nutrient that can contribute to eutrophication and dissolved oxygen loss in surface waters, especially in nitrogen-limited lakes, estuaries, and coastal embayments. Algae and aquatic weeds can contribute trihalomethane (THM) precursors to the water column that might generate carcinogenic THMs in chlorinated drinking water. Excessive nitrate-nitrogen in drinking water can cause methemoglobinemia in infants and pregnancy complications.
Phosphorus	Phosphorus is an aquatic plant nutrient that can contribute to eutrophication of phosphorus-limited inland surface waters. High algal and aquatic plant production during eutrophication is often accompanied by increases in populations of decomposer bacteria and reduced dissolved oxygen levels for fish and other organisms.

## Septage Management Programs

The primary objective of a septage management program is to establish procedures and rules for handling and disposing of septage in an affordable manner that protects public health and ecological resources. When planning a program it is important to have a thorough knowledge of legal and regulatory requirements regarding handling and disposal. USEPA (1994) has issued regulations and guidance that contain the type of information required for developing, implementing, and maintaining a septage management program.

Detailed guidance for identifying, selecting, developing, and operating reuse or disposal sites for septage is provided in Process Design Manual: Surface Disposal of Sewage Sludge and Domestic Septage, which is on the Internet at <http://www.epa.gov/ord/WebPubs/sludge.pdf>.

States and municipalities typically establish public health and environmental protection regulations for septage management (pumping, handling, transport, treatment, and reuse/disposal). Key components of septage management programs include tracking or manifest systems that identify acceptable septage sources, pumps, transport equipment, final destination, and treatment, as well as procedures for controlling human exposure to septage, including vector control, wet weather runoff, and access to disposal sites.

### **Septage Treatment/Disposal: Land Application**

The ultimate fate of septage generally falls into three basic categories- land application, treatment at a wastewater treatment plant, or treatment at a special septage treatment plant. Land application is the most commonly used method for disposing of septage in the United States.

Simple and cost effective, land application approaches use minimal energy and recycle organic material and nutrients back to the land. Topography, soils, drainage patterns, and agricultural crops determine which type of land disposal practice works best for a given situation. Some common alternatives are surface application, subsurface incorporation, and burial. Disposal of portable toilet wastes mixed with disinfectants, deodorizers, or other chemicals at land application sites is not recommended.

If possible, these wastes should be delivered to the collection system of a wastewater treatment plant to avoid potential chemical contamination risks at septage land application sites. Treatment plant operators should be consulted so they can determine when and where the septage should be added to the collection system.

When disposing of septage by land application, appropriate buffers and setbacks should be provided between application areas and water resources (e.g., streams, lakes, sinkholes). Other considerations include vegetation type and density, slopes, soils, sensitivity of water resources, climate, and application rates. Agricultural products from the site must not be directly consumed by humans.

### **Land application practices include the following:**

#### **Spreading by Hauler Truck or Farm Equipment**

In the simplest method, the truck that pumps the septage takes it to a field and spreads it on the soil. Alternatively, the hauler truck can transfer its septage load into a wagon spreader or other specialized spreading equipment or into a holding facility at the site for spreading later.

### **Spray Irrigation**

Spray irrigation is an alternative that eliminates the problem of soil compaction by tires. Pretreated septage is pumped at 80 to 100 psi through nozzles and sprayed directly onto the land. This method allows for septage disposal on fields with rough terrain.

### **Ridge and Furrow Irrigation**

Pretreated septage can be transferred directly into furrows or row crops. The land should be relatively level.

### **Tank Access**

Access to the septic tank is necessary for pumping septage, observing the inlet and outlet baffles, and servicing the effluent screen. Both manways and inspection ports are used.

Manways are large openings, 18 to 24 inches in diameter or square. At least one that can provide access to the entire tank for septage removal is needed. If the system is compartmentalized, each compartment requires a manway. They are located over the inlet, the outlet, or the center of the tank. Typically, in the past manway covers were required to be buried under state and local codes. However, they should be above grade and fitted with an airtight, lockable cover so they can be accessed quickly and easily.

Inspection ports are 8 inches or larger in diameter and located over both the inlet and the outlet unless a manway is used. They should be extended above grade and securely capped.

**(CAUTION:** The screen should not be removed for inspection or cleaning without first plugging the outlet or pumping the tank to lower the liquid level below the outlet invert.

Solids retained on the screen can slough off as the screen is removed.

These solids will pass through the outlet and into the SWIS unless precautions are taken. This caution should be made clear in homeowner instructions and on notices posted at the access port.)

Septic tank designs for large wastewater flows do not differ from designs for small systems. However, it is suggested that multiple compartments or tanks in series be used and that effluent screens be attached to the tank outlet. Access ports and manways should be brought to grade and provided with locking covers for all large systems.

Residuals are normally produced as a result of wastewater treatment. The term “septage” is commonly used to describe the liquids and solids that are pumped from a septic tank, port-a-potty, cesspool, or other locality. EPA regulates the management of septage to ensure that this material is treated, used, and/or disposed of in an environmentally sound manner.

Septic tanks with soil absorption systems are the most commonly used individual wastewater treatment system in rural and suburban areas. Untreated household waste flows into the tank where the solids separate from the liquid. Light solids, such as soap suds and fat, float to the top and form a scum layer.



The liquid waste goes into the drainfield, while the heavier solids settle to the bottom of the tank where the organic matter is partially decomposed by anaerobic bacteria. Some non-decomposed solids remain, forming a sludge layer that eventually must be pumped out. A septic tank will usually retain 60 to 70 percent of incoming solids, oil, and grease.

Because it is concentrated, the strength of septage is generally fifty to several hundred times greater than municipal wastewater. The physical characteristics of septage vary depending upon the septic tank size, design, and pumping frequency; user habits; climatic conditions; water supply characteristics, and the use of garbage disposals, household chemicals, and water softeners. It is important that samples of septage be collected and tested to determine local characteristics, since they can affect the proper management of these materials.

**In its Septage Treatment and Disposal Fact Sheet (EPA 832-F-99-068; September, 1999), EPA describes septage as:**

Highly variable and organic, with significant levels of grease, grit, hair, and debris. The liquids and solids pumped from a septic tank or cesspool have an offensive odor and appearance, a tendency to foam upon agitation, and a resistance to settling and dewatering. Septage is also a host for many disease-causing viruses, bacteria, and parasites.

The volume of residuals generated by a wastewater system will vary based on the treatment method. A general method to determine septage generation appears below.

Some advanced treatment units, such as activated sludge-based aerobic treatment unit (ATU) systems, can significantly increase the volume of residuals generated. In contrast, filtration technologies are often used to minimize the generation of residuals.



## General Method to Determine Septage Generation

volume pumped (1) x residences served / frequency of pumping (2) = annual volume

(1) - Typical default values for septage are 1,000 gallons (septic tank volume) per pumping

(2) - Frequency default value is every five years.

**Note:** Some advanced treatment units will significantly increase the volume of residuals generated. If pumping occurs on an as-needed basis, residuals management (receiving) facilities will need a significantly larger short-term capacity for processing. The method of residuals processing may also require some additional evaluation of septage characteristics.

An annual inspection, with pumping as required, is the most reliable way to maintain the health of your septic tank and leach field. The most common cause of septic system failure is sludge overflow in the leach field resulting in a costly replacement of the leach field.

### How Often is Pumping Required?

This depends on the following:

- Capacity of septic tank.
- Number in household.
- Volume of wastewater.
- Volume of solids in wastewater.

ESTIMATED SEPTIC TANK PUMPING FREQUENCY IN YEARS						
Tank Size (gallons)	Household Size (number of people)					
	1	2	3	4	5	6
500	6	3	2	1	1	0.5
750	9	4	3	2	1.3	1.0
900	11	5	3.5	2	1.7	1.5
1000	12	9	4	3	2.0	1.5
1250	15	8	5	3.5	2.5	2.0
1500	19	9	6	4	3	2.5
1750	22	11	7	5.0	4	3
2000	25	12	8	6	4.5	3.5
2250	29	14	9	7	5	4
2500	32	16	10	8	6	5

## Federal Septage Rules

In 1993, EPA issued regulations that address septage use and disposal practices as part of Chapter 40 of the Code of Federal Regulations. 40 CFR part 503 regulates domestic septage as a part of the requirements controlling the use and disposal of sewage sludge.

The rule defines “domestic septage” as liquid and solid material removed from a septic tank, cesspool, portable toilet, Type III marine sanitation device, or similar treatment works that receive only domestic sewage. The 503 regulation includes minimum requirements for land application of domestic septage applied to non-public contact sites such as agricultural fields, forestland, and mine reclamation areas.

40 CFR Part 257 governs the management of grease trap wastes and other types of residuals resulting from the treatment of non-domestic sewage by individual and clustered commercial and industrial treatment systems.

40 CFR Part 258 governs the disposal of septage, sewage sludge, and other residuals into municipal solid waste landfills.

### The Federal 503 Rule

Requires domestic septage pumpers to meet four basic requirements:

- ✓ Meet (and certify) applicable pathogen and vector attraction reduction requirements.
- ✓ Follow specific management practices.
- ✓ Ensure that septage is from domestic sources only.
- ✓ Keep records on land application sites, rates, etc.

Most states build upon the federal 40 CFR part 503 regulation as the minimum requirements for managing septage, although states may and often do impose more stringent requirements. In some cases, municipalities have established local regulations for septage handling, treatment, and disposal in addition to the federal and state regulations.

For example, Minnesota has developed a model local ordinance for Land Application of Septage at Non-Public Contact Sites. The ordinance builds upon the federal 503 rule for land application. It provides pumpers with detailed information on site suitability, separation distances to features such as surface waters and wells, and detailed site management requirements.

### Disposal Options

Septage can be processed through land application, at wastewater treatment plants, or at processing facilities specifically designed to treat septage. The following section describes these alternatives:

### Land Application

Domestic septage contains nutrients that can condition the soil and decrease reliance on chemical fertilizers for agriculture production. Typically, the best land application sites are located in isolated or remote areas. Both tilling the soil and adding lime to septage may benefit crop production. Adjusting septage pH can also reduce or eliminate odors and disease-causing organisms before land application.

### **Subsurface Application**

Subsurface application, or surface application with subsequent incorporation, are the preferred methods for land application of septage since they minimize odors, reduce vector attraction, minimize ammonia volatilization losses, conserve nitrogen, minimize contact with rain, and reduce potential water contamination. State regulations for land application of septage often require pre-approval from the regulating agency through permits and/or licenses, soil tests, and site management plans.

A storage or transfer tank may be needed when land application sites are inaccessible due to weather conditions or if pre-application treatment of the septage is required. Some states require septage to be disinfected before application.

### **Pretreatment**

Pretreatment, such as screening and grit removal, may also be necessary prior to discharge into a tank or lagoon. Enclosed holding tanks or lined lagoons in isolated areas are preferred temporary storage facilities. Additional information can be found in EPA's design manuals for land application (EPA/625/R-95/001) and surface disposal (EPA/625/R-95/002), and its "Guide to Septage Treatment and Disposal" (EPA/625/R-94/002). One of the major concerns regarding land application is odor and pathogen problems. Pretreatment and stabilization can reduce minimize odors. The simplest and most economical method is to add lime or other alkali to raise the pH to 12 for a minimum of 30 minutes.

Other septage stabilization options include aerobic digestion, anaerobic digestion, and composting. Relative to alkaline stabilization, these options have higher operating costs and require more skilled operating personnel. A number of states require septage be stabilized before it is applied to the land. Michigan law includes a requirement to screen all septage prior to land application and bans septage waste application on frozen soil.

Surface disposal of septage is another alternative outlined under the federal rules. This includes disposal in holding lagoons, trenches, and sanitary landfills. Some states, however, have more restrictive rules concerning burial. For example, Georgia does not allow burial of septage in trenches or lagoons.

### **Publicly Owned Treatment Works (POTWs)**

Septage can also be handled and processed at wastewater treatment plants. This process usually employs a septage receiving station, which pretreats the septage by screening and other unit processes. Some of these facilities separate the liquid from the solids, which are then processed by the POTW. The allowable amount of septage handled by a POTW is a function of the type and size of the treatment plant, capacity of the plant, and characteristics of the septage.

Smaller POTWs must be cognizant of how the higher-strength septage will affect overall wastewater organic loads and should control the feed rate. Pretreatment may be required to prevent problems in the treatment system.

EPA has developed a guidance manual for the Control of Waste Hauled to Publicly Owned Treatment Works (EPA-832-B-98-003; September, 1999) for smaller POTWs on how to develop and implement hauled waste controls. Larger systems can more easily handle septage without process upset. POTWs should track each septage load to identify any potential for a system upset.

### **Independent Septage Treatment Facility (ISTF)**

When suitable land is unavailable and wastewater treatment facilities are too distant or do not have adequate capacity, independent septage treatment plants may be an option. ISTFs vary from stabilization lagoons to treatment plants that use aerobic digestion, anaerobic digestion, composting, and other biological and chemical treatment processes.

One of the advantages of an ISTF over a conventional POTW is that unlimited amounts of grease trap wastes can be processed. However, in recent years, a growing number of POTWs (e.g., East Bay Municipal Utilities District in California and West Lafayette, Indiana) have modified their operations to accommodate the processing of fats, oils, and grease; food wastes; and other organic residuals, while increasing the biogas production from their sewage sludge anaerobic digesters for use in generating onsite power or conversion to biofuels.

Advantages and Disadvantage of Various Treatment Methods Selecting the appropriate septage treatment approach depends on several factors including:

- Capacity of approved treatment facilities
- State and local regulatory requirements
- Land availability and site conditions
- Costs (fuel, labor, and dispersal costs)

### **Management Considerations**

The safe, practical, and acceptable practices for the use or disposal of septage should be a key goal of any wastewater management program. Septage management plans must be developed within the context of state, local, and federal rules and the nature of residuals produced. The general state of septage management can be summed up by the following statement from a survey conducted by California:

A 2002 survey of local onsite wastewater programs in California revealed that less than half of the jurisdictions tracked the total volume of septage handled. Most did not have information on the number of pumper vehicles and companies operating within their jurisdiction. Of the 81 septage facilities identified, several were no longer receiving septage or were closed. Based on these findings, the California Wastewater Training and Research Center recommended the development of a comprehensive septage management plan to continually assess septage capacity needs and design strategies.

To manage septage there are a number of questions that must first be asked to develop an appropriated septage handling and treatment program including:

- What are the current residuals handling practices?
- How much septage is being generated now, and how much will be generated when all planned new development and treatment facilities are in place?
- Where are pumpers currently discharging their trucks?
- What is the capacity of each of those sites versus the needed capacity?
- Can we secure any needed capacity or performance improvement without a major municipal investment?
- Can we secure agreements with receiving facilities to handle the ultimate volume of residuals generated at the design condition?
- Do the existing septage receiving facilities comply with the 40 CFR part 503 requirements and part 257 guidance?

- How can the management program provide support (e.g., public education and involvement, service provider training, financing for system upgrades) to overcome any barriers?
- What should fees be to assure a sustainable receiving, treatment, and use or disposal program?
- Ultimately, each state must adopt its own unique approach based on its needs and regulatory authorities.

### **Septage Management state and Local Examples**

Ohio provides low-interest loans to communities for the installation of septage receiving facilities. The intent of the Ohio program is to establish a grid of POTWs with septage receiving capabilities.

Yarmouth/Dennis, Massachusetts, financed an independent septage treatment facility with advanced processing and liquid-stream soil dispersal to avoid an excessively high-cost sewer. Both Wisconsin and New Hampshire incorporate septage planning into municipal wastewater planning requirements.

The Town of Pittsfield, Maine, conducted a septage pilot study in 2003-2004. The process used pretreatment, including manual screening of the raw septage; conditioning raw septage with lime; blending in ferric chloride and polymer; trapping the gross solids in a dewatering container; and treating only the liquid filtrate in the existing aerated lagoon facility.

The Pittsfield Water Pollution Control Federation (WPCF) processed more than 1.3 million gallons of raw septage during the pilot study, with the best plant performance observed when filtrate total phosphorous was less than 2 mg/l. Results of the pilot study were favorable for developing a long-term expansion of Pittsfield's septage receiving facility.

A proper management program should have an inventory of individual and clustered wastewater systems within their area. These inventories are typically kept current through periodic reporting of septage removal by system owners, service providers, or both. The management facility that accepts residuals is responsible for compliance with the part 503 recordkeeping requirements. Facilities must keep records and produce them on demand for authorized regulators.

Most states require the haulers to keep records for a minimum of five years and use manifests to track septage. A local government may also require haulers to obtain permits to operate within its jurisdiction. Permits may cover septic tank pumping, treatment at a sewage treatment plant, land application, or treatment at an independent septage treatment facility.

### **Operation and Maintenance**

The need to pump septage from small wastewater systems cannot be overstated. Without proper operation and maintenance, soil absorption systems will malfunction and can potentially impair water quality or cause sewage surfacing and threats to public health. In most cases, the homeowner is responsible for maintenance of their treatment system.

Some communities, however, have strengthened their wastewater programs by conducting periodic inspections of individual treatment systems and maintaining pumping records to better monitor when pumping is needed. In these communities, the system owner is required to have his or her tank pumped by a locally approved hauler within a given time period and provide documentation that the tank was pumped in accordance with local requirements.

Another approach is for a responsible management entity to assume complete responsibility for inspecting, pumping, and disposing of septage. In all cases, the management program goal should be to pump, transport, treat, and use or dispose of the residuals in a manner that has the least impact on the system owners, the community, and the environment.

### **Training, Certification, and Licensing**

The National Association of Wastewater Transporters conducts a comprehensive training and certification program for pumpers and haulers. Several states have also established training centers to promote proper handling and disposal of septage. For example, Wisconsin requires all septage operators to pass an exam in order to become a certified septage operator.

Several management programs also provide system owners with access to a list of certified service providers to promote proper septage management. North Carolina requires training and certification for land application operators and has similar requirements for pumpers. The state also provides a listing of certified land application operators.

### **State and Local Examples**

Septage operators in Wisconsin are required to pass an exam to be certified. Two levels of certification are available for septage servicing and land application. State rules require continuing education credits to maintain an active certification.

Ohio rules that took effect on January 1, 2007, require that sewage treatment system installers, service providers, and septage haulers that register with a local health district to perform work required under this chapter take a state examination. The Ohio Department of Health is the state agency responsible for the implementation (<http://www.ohionsite.org/>).

### **Public Education**

Wastewater management programs require that community residents be informed about pumping and proper disposal of septage. Programs must reinforce O&M requirements and proper septage handling and disposal procedures, especially targeting the pumpers and haulers. Citizen feedback and input loops should be incorporated into the management program to maintain program support.

The York County Authority in Pennsylvania publishes newspaper notices informing residents about proper septage system pumping and use of licensed haulers. The authority also created a biosolids learning station, and presentations on the topic are available to school and civic groups at no cost.

Most states with licensing and certification requirements provide listings of approved septic pumpers and haulers. For example, Oklahoma provides a Web-based data-base of licensed pumpers and haulers.

### **Inspections and Compliance**

Numerous states inspect septage pumping businesses. Inspections typically consist of reviewing 40 CFR part 503 requirements with pumpers, including record keeping, liming practices, and site management.

Oklahoma has developed a Septage Hauling and Pumping Inspection form to conduct inspections of septage operations and investigate complaints. Minnesota conducts a compliance inspection for all new disposal sites.





## Onsite References and Credits

U.S. Environmental Protection Agency. Feb. 2002. Onsite Wastewater Treatment Systems Manual. EPA-625-R-00-008.

Ohio State University. Soil and Site Evaluation for Onsite Wastewater Treatment. Bulletin 905. EPA-625-R-00-008.

Paul Trotta, P.E., Ph.D., Justin Ramsey, P.E., Chad Cooper, Northern Arizona University

David Lindbo, Ph.D. NC State University. September 2004. University Curriculum Development for Decentralized Wastewater Management - Site Evaluation Module Text.

<http://onsite.tennessee.edu/University%20Site%20and%20Soil%20Evaluation.pdf>

University of Nebraska –Lincoln Extension. Sept. 2006. Residential Onsite Wastewater Treatment: Site Evaluation.

S.A. Holden, M.H. Stolt, G.W. Loomis, and A.J. Gold. Seasonal Variation in Nitrogen Leaching from Shallow-Narrow Drainfields. Abstract retrieved from the World Wide Web January 3, 2007. <http://asae.frymulti.com/abstract.asp?aid=15802&t=1>

U.S. Environmental Protection Agency. Sept. 1999. The Class V Underground Injection Control Study. EPA/816-R-99-014e. Volume 5, Large-Capacity Septic Systems. Retrieved from the World Wide Web January 3, 2007. [http://www.epa.gov/ogwdw/uic/class5/classv\\_study.html](http://www.epa.gov/ogwdw/uic/class5/classv_study.html)

Poeter, Thyne, McCray, and Siegrist. Jan. 2005. Colorado School of Mines Golden, Colorado Guidance for Evaluation of Potential Groundwater Mounding Associated with Cluster and High-Density Wastewater Soil Absorption Systems.

[http://www.ndwrcdp.org/userfiles/WUHT0245\\_Electronic.pdf#search=%22Guidance%20for%20Evaluation%20of%20Potential%20Groundwater%20Mounding%20Associated%20with%20Cluster%20and%20HighDensity%20](http://www.ndwrcdp.org/userfiles/WUHT0245_Electronic.pdf#search=%22Guidance%20for%20Evaluation%20of%20Potential%20Groundwater%20Mounding%20Associated%20with%20Cluster%20and%20HighDensity%20)

[Wastewater%20Soil%20Absorption%20Systems%20%22](http://www.ndwrcdp.org/userfiles/WUHT0245_Electronic.pdf#search=%22Guidance%20for%20Evaluation%20of%20Potential%20Groundwater%20Mounding%20Associated%20with%20Cluster%20and%20HighDensity%20)

Wallace and Grubbs in Proceedings of 13th Annual NOWRA Conference. July 2003. Hydrogeological Evaluations for Larger Cluster and High Density Wastewater Soil Absorption Systems.

[http://www.ndwrcdp.org/userfiles/CSM-HYDRO\\_1\\_PROG\\_SUMM\\_1ST\\_Q\\_03.pdf](http://www.ndwrcdp.org/userfiles/CSM-HYDRO_1_PROG_SUMM_1ST_Q_03.pdf)

Tyler, EJ, 2001. Hydraulic Wastewater Loading Rates to Soil.

Anderson, J. and D. Gustafson, University of Minnesota Extension Service, 1998. Residential Cluster Development: Alternative Wastewater Treatment Systems.

<http://www.extension.umn.edu/distribution/naturalresources/components/7059-02.html>

American Society for Testing and Materials, 1996. Standard Practice for Subsurface Site Characterization of Test Pits. ASTM Practice D5921-96, Not available online. To purchase see <http://www.astm.org/cgi-bin/SoftCart.exe/>

DATABASE.CART/REDLINE\_PAGES/D5921.htm?E+mystore E-Handbook for Managing Individual and Clustered (Decentralized) Wastewater Treatment Systems 11

Advanced On-Site Wastewater Treatment and Management Scoping Study: Assessment of Short-Term Opportunities and Long-Run Potential. Prepared for the Electric Power Research Institute, the National Rural Electric Cooperative Association, and the Water Environment Research Federation. Ohio Environmental Protection Agency (Ohio EPA). 1997.

A Guide to Developing Local Watershed Action Plans in Ohio. Ohio Environmental Protection Agency, Division of Surface Water, Columbus, OH. Otis, J. 2000. Performance management. Small Flows Quarterly 1(1):12.

**Credits:**

PIPELINE, a quarterly publication of the National Small Flows Clearinghouse, for providing information used in this guide.

Onsite Sewage Treatment Program, University of Minnesota. 2011. Manual for Septic System Professionals in Minnesota, 2nd Ed. St. Paul, MN.

Baumann, E.R., and H.E. Babbit. 1953. An Investigation of the Performance of Six Small Septic Tanks. University of Illinois Engineering Experiment Station. Bulletin Series No. 409. Vol. 50, No. 47. University of Illinois, Urbana, IL.

Baumann, E.R., E.E. Jones, W.M. Jakubowski, and M.C. Nottingham. 1978. Septic Tanks. In Home Sewage Treatment: Proceedings of the Second National Home Treatment Symposium. American Society of Agricultural Engineers, St. Joseph, MI.

Berkowitz, S.J. 1985. Pressure Manifold Design for Large Subsurface Ground Absorption Sewage Systems. In Onsite Wastewater Treatment: Proceedings of the Fourth National Symposium on Individual and Small Community Sewage Systems. American Society of Agricultural Engineers, St. Joseph, MI.

Berkowitz, S.J., and J.R. Harman. 1994. Computer Program for Evaluating the Hydraulic Design of Subsurface Wastewater Drip Irrigation System Pipe Networks. In On-Site Wastewater Treatment: Proceedings of the Seventh International Symposium on Individual and Small Community Sewage Systems, ed. E. Collins. American Society of Agricultural Engineers, St. Joseph, MI.

## Post Quiz

### Internet Link to Assignment...

<http://www.abctlc.com/downloads/PDF/Onsite101Ass.pdf>

#### Septic System Basics *Described*

1. Most tanks are split into two compartments and have pipe baffles and an outlet filter to ensure the \_\_\_\_\_ stay in the tank.
2. Final treatment of the effluent always occurs in the soil where additional microbes break down the waste and the "clean" water is put back into the ground thereby recharging the aquifers.  
A. True      B. False
3. Wastewater contains several undesirable pollutants.  
A. True      B. False
4. Pathogens such as viruses or bacteria cannot enter drinking water supplies creating a potential health hazard.  
A. True      B. False
5. Nutrients and organic matter entering waterways can lead to tremendous death of aquatic microorganisms.  
A. True      B. False

#### Types of Systems – General

6. Standard gravity systems require \_\_\_\_\_ feet of "good" soil under the trenches while pressure distribution systems only require \_\_\_\_\_ feet.
7. Advanced Treatment systems are more complicated and treat the wastewater to a fairly high level before allowing it to reach the soil. Because of this treatment, they can be used where there is only \_\_\_\_\_ foot of "good" dirt beneath the trench bottom.

#### Conventional Septic Systems Typically have three Main Components.

8. Which of the following separates the solids from the liquids, and serves a storage area for the solids to decompose and if properly maintained will decompose the solids faster than they build up?

#### Pressure Distribution

9. Pressure distribution systems are usually required when there is less than optimal soil depth available for complete treatment of the effluent by \_\_\_\_\_.
10. A minimum of \_\_\_\_\_ feet of properly drained soil is required under the trenches.

#### Conventional Septic Systems

11. Which of the following are the most commonly used wastewater treatment technologies, combining primary and secondary treatment?

12. Conventional treatment systems are the least expensive in terms of total cost but require specific conditions (e.g., at least \_\_\_\_\_ inches of unsaturated soil) and maintenance to perform adequately.

### **Basic Onsite Wastewater Treatment Systems and Components**

13. Building sewers and other sewer lines: watertight pipes, which deliver waste by \_\_\_\_\_ from a building to the onsite system or carry effluent by gravity from sewage tanks to other system components.

### **Septic Tanks**

14. The septic tank's function is to separate solids from liquid, digest organic matter, store liquids through a period of detention and allow the \_\_\_\_\_ to discharge to other components of an onsite system.

### **Septic/Sewage Tank Removal**

15. \_\_\_\_\_ need to be properly abandoned to prevent them from becoming a safety hazard.

### **Septic Treatment**

16. A septic tank removes many of the settleable solids, oils, greases, and floating debris in the raw wastewater, achieving \_\_\_\_\_ percent removal.

### **Answers**

1. Solids, 2. True, 3. True, 4. False, 5. False, 6. 3 & 2, 7. 1, 8. A septic tank, 9. A gravity system, 10. Two, 11. Conventional treatment systems, 12. 24-36, 13. Gravity, 14. Clarified liquids, 15. Unused sewage tanks, 16. 60 to 80

## Chapter 2- ONSITE OPERATION AND MAINTENANCE SECTION

**Section Focus:** You will learn about the Clean Water Act and the basics of maintaining the decentralized or onsite wastewater facility and its operational requirements. At the end of this section, you the student will be able to describe the basics of decentralized wastewater facility maintenance and failures. There is a post quiz at the end of this section to review your comprehension and a final examination in the Assignment for your contact hours.

**Scope/Background:** Onsite sewage treatment system installers/operators provide and maintain septic systems in compliance with all state and federal requirements and permits to ensure that untreated wastewater will not contaminate the environment or pollute waterways.

STANDARD SEPTIC SYSTEM

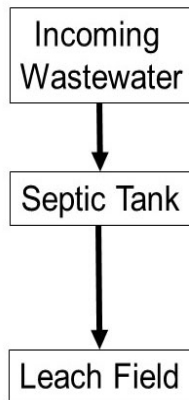

I/A SEPTIC SYSTEM

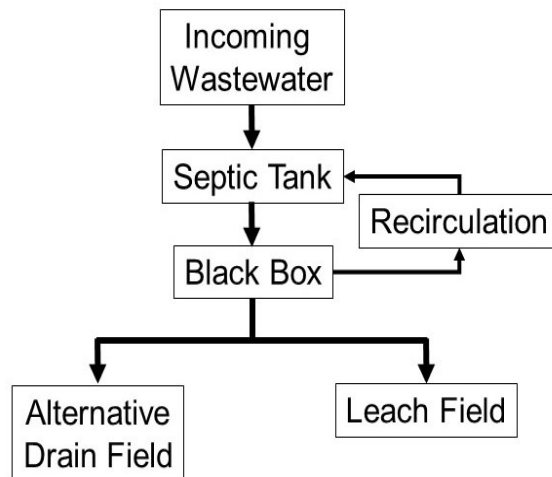

### DIAGRAM OF A SEPTIC SYSTEM

#### Effective Wastewater Management

Effective wastewater management ultimately hinges on the proper O&M of systems. A very important, but often overlooked, component of a wastewater management program is operation and maintenance (O&M).

There are several different management approaches that can be used to support O&M, from mandatory inspection programs to permitting and monitoring requirements.

In general, operation and maintenance tasks are tied directly to the system type, the wastewater being treated, and the receiving environment where effluent is discharged or dispersed.

This overview provides readers with general information about the O&M management considerations for individual and clustered wastewater treatment systems.

## **Included in this Overview are:**

### **System Operation and Maintenance Requirements**

- ✓ Individual Wastewater Systems
- ✓ Clustered Treatment Systems

### **Management Considerations**

- ✓ Education and Outreach
- ✓ Training and Certification
- ✓ Inspection and Maintenance Requirements
- ✓ Maintenance Contracts
- ✓ Reporting and Monitoring
- ✓ Operating Permits
- ✓ Public and Private Management Entities

## **System Operation and Maintenance Requirements**

There are distinct, ongoing O&M requirements associated with the various individual and clustered wastewater collection and treatment systems and the technologies employed. Most technologies come with suggested O&M maintenance activities from the manufacturer. These requirements are crucial to the proper operation and performance of the system.

When soil limitations exist, adjustments to the upstream treatment train may be needed to reduce biochemical oxygen demand, total suspended solids, bacteria levels, nutrients, or other pollutants. Adjustments could involve reducing pollutant inputs at the source (e.g., better plate and pot scraping prior to dishwashing in restaurant kitchens, adding grease trap tanks, etc.), applying the effluent at lower soil loading rates, or inserting a fixed film or suspended growth treatment unit between the septic tank and drainfield.

## Septic System Failures

Septic system failures are a major source of groundwater pollution. Layers of soil act as a natural filter, removing microbes and other particles as water seeps through. Improperly treated water can carry bacteria and viruses that can cause gastroenteritis, fever, common cold, respiratory infections and hepatitis. Septic system maintenance is like automobile maintenance; a little effort on a regular basis can save you a lot of money and significantly prolong the life of the system.

Septic systems are effective, cost efficient, and easy to maintain. However, failing systems are a major source of groundwater pollution, cause waterborne illnesses, such as dysentery and hepatitis, and are expensive for homeowners to replace. There are many different types of wastewater collection and treatment technologies.

Systems can treat individual homes, clusters of buildings, or whole subdivisions and/or commercial establishments. Collection systems for clustered facilities can work by gravity or operate via vacuum or pressure pump. Wastewater is typically treated through primary and secondary processes (and sometimes tertiary or advanced “polishing” procedures) and can be disinfected prior to discharge.



A septic system failure causes **untreated sewage to be released and transported to where it should not be**. This may cause sewage to come to the surface of the ground around the tank or the drainfield or to back up in pipes in the building.

Most septic systems fail because of inappropriate design or poor maintenance. Some soil-based systems (those with a drain field) are installed at sites with inadequate or inappropriate soils, excessive slopes, or high ground water tables. These conditions can cause hydraulic failures and contamination of nearby water sources.

Failure to perform routine maintenance, such as pumping the septic tank generally at least every three to five years, can cause solids in the tank to migrate into the drain field and clog the system.

There are a number of resources available online that can provide additional information on individual and cluster system designs including:

- ✓ EPA Design Manual
- ✓ EPA Onsite Wastewater Treatment Systems Manual
- ✓ EPA Onsite Technology Fact Sheets
- ✓ Small Flows Clearinghouse Environmental Technology Initiative (ETI) Fact sheets
- ✓ EPA Alternative Wastewater Collection Systems Handbook
- ✓ Cluster System Planning Handbook
- ✓ University of Minnesota Innovative Onsite Treatment Systems
- ✓ Rutgers University Onsite Wastewater Treatment Systems: Alternative Technologies
- ✓ New England Interstate Water Pollution Control Commission



## Operation, Maintenance, and Monitoring

Subsurface wastewater infiltration systems require little operator intervention. The table below lists typical operation, maintenance, and monitoring activities that should be performed. However, more complex pretreatment, larger and more variable flows, and higher-risk installations increase the need for maintenance and monitoring.

**Operation, Maintenance, and Monitoring Activities Table**

<b>Task</b>	<b>Description</b>	<b>Frequency</b>
Water meter reading	Recommended for large, commercial systems	Daily
Dosing tank controls	Check function of pump, switches, and times for pressure-dosed systems	Monthly
Pump calibration	Check pumping rate and adjust dose timers as appropriate for pressure-dosed systems	Annually
Infiltration cell rotation	Direct wastewater to standby cells to rest operating cells	Annually (optimally in the spring)
Infiltration surface ponding	Record wastewater ponding depths over the infiltration surface and switch to standby cell when ponding persists for more than a month	Monthly
Inspect surface and perimeter of SWIS	Walk over SWIS area to observe surface ponding or other signs of stress or damage	Monthly
Tank solids levels and integrity assessment	Check for sludge and scum accumulation, condition of baffles and inlet and outlet appurtenances, and potential leaks	Varies with tank size and management program

### Failures and Contingencies

Onsite wastewater systems can and do fail to perform at times. To avoid threats to public health and the environment during periods when a system malfunctions hydraulically, contingency plans should be made to permit continued use of the system until appropriate remedial actions can be taken.

Contingency options should be considered during design so that the appropriate measures are designed into the original system.

### Contingency Options for SWIS Malfunctions Table

Contingency Option	Description	Comments
Reserve area	Unencumbered area of suitable soils set aside for a future replacement system.	Does not provide immediate relief from performance problems because the replacement system must be constructed. The replacement system should be constructed such that use can be alternated with use of the original system.
Multiple cells	Two or more infiltration cells with a total hydraulic capacity of 100% to 200% of the required area that are alternated into service.	Provide immediate relief from performance problems by providing stand-by capacity. Rotating cells in and out of service on an annual or other regular schedule helps to maintain system capacity. Alternating valves are commercially available to implement this option. The risk from performance problems is reduced because the malfunction of a single cell involves a smaller proportion of the daily flow.
Water conservation	Water-conserving actions taken to reduce the hydraulic load to the system, which may alleviate the problem.	A temporary solution that may necessitate a significant lifestyle change by the residents, which creates a disincentive for continued implementation. The organic loading will remain the same unless specific water uses or waste inputs are eliminated from the building or the wastewaters are removed from the site.
Pump and haul	Conservation of the septic tank to a holding tank that must be periodically pumped. The raw waste must be hauled to a suitable treatment and/or disposal site.	Holding tanks are a temporary or permanent solution that can be effective but costly, creating a disincentive for long-term use.

## Regular Maintenance Introduction

Regular maintenance is required for all systems. However, it is especially important for more complex alternative systems, especially those that use pumps, controls, timers, and pressure distribution. Verification of system maintenance contracts, operator expertise, and reporting requirements for system maintenance such as tank pumping and repairs should be included in the approval process. Most Authorities have developed an approval application for alternative systems which includes:

- ✓ Certification to the National Sanitation Foundation (NSF) International Class I Standard 40 Protocol.
- ✓ Documentation that the system meets state performance requirements.
- ✓ A guide for inspecting system installations.
- ✓ A plan for training agents and system installers on installation and inspection.
- ✓ A plan for training operation and maintenance providers.
- ✓ Detailed plans showing that the system complies with the state requirements

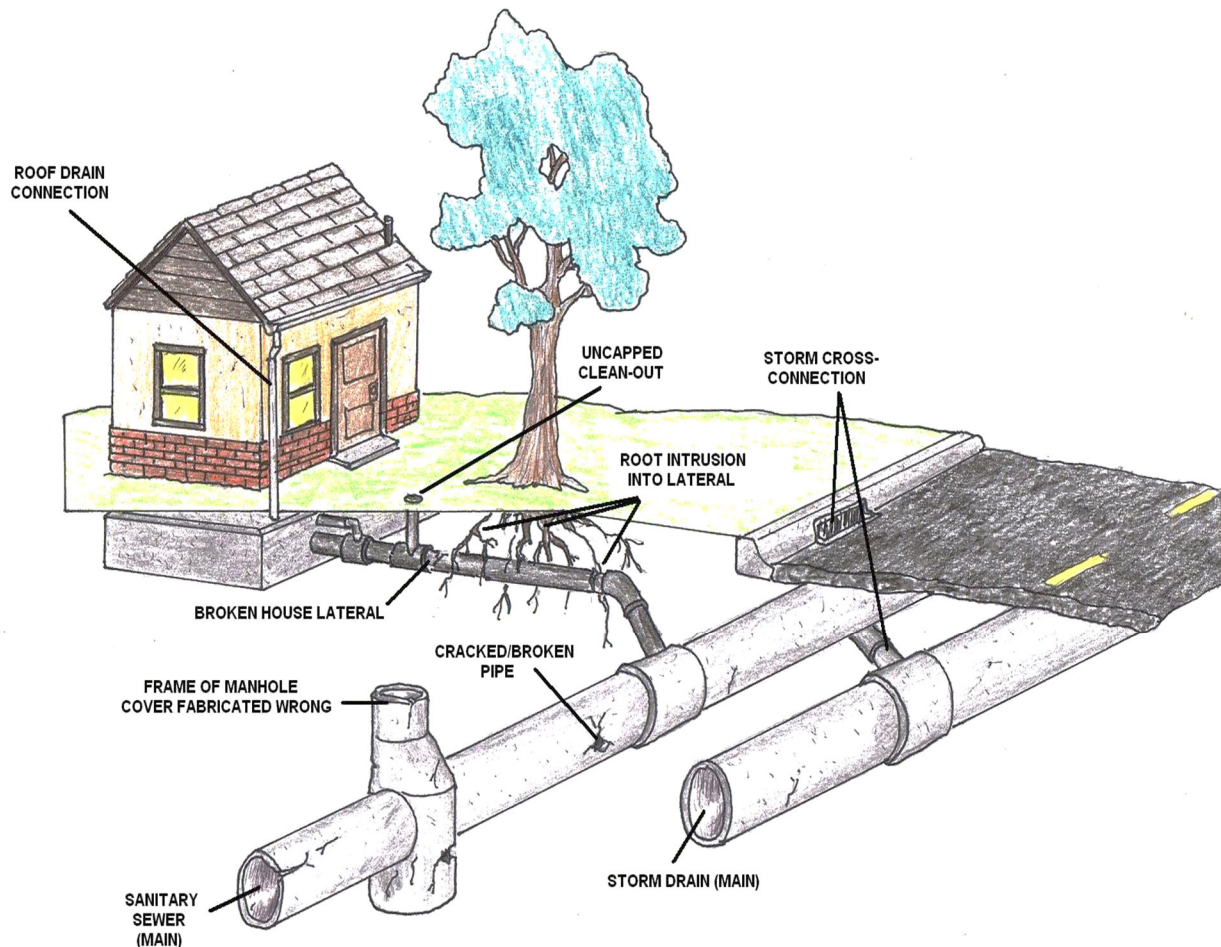

The diagram above shows many problems that customers will associate with septic tanks, however, these common problems are related to the collection system.

### **Maintenance Legal Definition**

Means taking the actions necessary to keep onsite system components properly functioning as designed. Maintenance is further defined as:

(a) Major Maintenance is cleaning, repairing or replacing a broken or plugged effluent sewer pipe where:

(A) The pipe is the same make and model; or

(B) The pipe meets the requirements in this division; and

(C) A certified maintenance provider or certified licensed installer performs the work.

(b) Minor Maintenance includes, but is not limited to, repairing or replacing of a tank riser or lid, or pump, screen, filter, or other component internal to the tank that:

(A) Is the same make and model; or

(B) Meets the requirements of government regulations.

### **A Completed Checklist**

A system operation and maintenance manual outlining minimum maintenance frequency

The TOP warning signs of septic system failure:

1. Slowly draining sinks and toilets
2. Gurgling sounds in the plumbing
3. Plumbing backups
4. Sewage odors in house or yard
5. Ground wet or mushy underfoot over the drainfield
6. Grass growing faster or greener in one area of the yard
7. Drinking water tests showing presence of bacteria

None of these warning signs is a sure indicator that a system has failed, but you should investigate further if one or more of these signs is present!

### **Check the Record**

Unlike the other parts of a house, the septic system is difficult to see! However, you can check the records on a home's septic system by contacting your local or state sewer or septic agency or environmental agency.

### **These Records Should Reflect:**

1. The age of the system. If properly designed, installed, and maintained, a septic system can effectively treat household wastewater for up to 20 years or more. Look to see if the house has a system that is near the end of its life span.

2. The size of the system. Size is important because graywater (laundry water, sink water) and blackwater (toilet water) need to be retained in the tank for at least a day or more to allow solids to separate from the liquids and begin breaking down. If wastewater is pushed through without proper settling, the solids can clog the drainfield, stressing and possibly damaging the system. Adequate tank size is 1,000 gallons for a home with up to three bedrooms plus 250 gallons for each additional bedroom in the home.

3. The location of the system. Knowing where the tank and drainfield are will help you visually check the area for obvious signs of failure. In addition, poorly sited drainfields can result in septic system failures. Location of the system in relation to wells, other septic systems, slope of the land, natural drainage patterns, underlying soil conditions, and lot boundaries may indicate potential problems with the septic system and should be reviewed by you - the professional.

**Tip:** Keep an eye out for previous certifications from your state sewer or septic agency or environmental agency; these should indicate that the system is in compliance with good septic system standards, or will indicate any waivers that were granted and why.

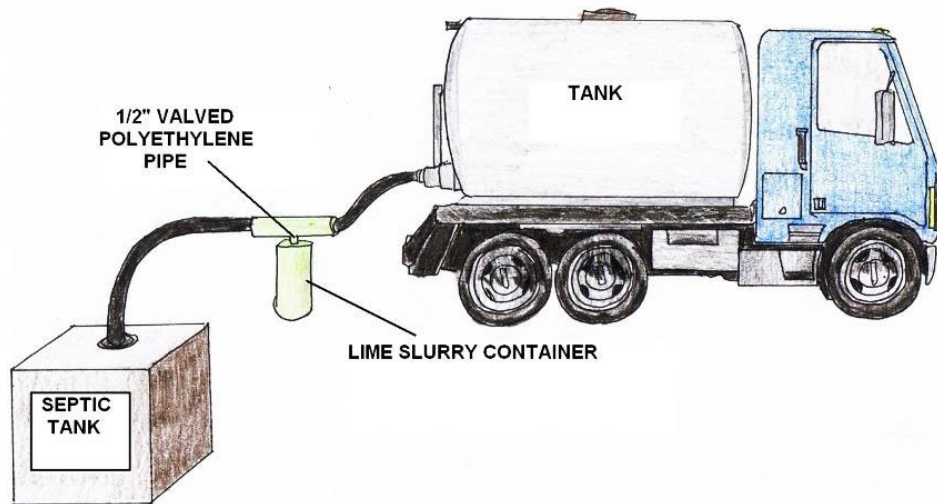

ESTIMATED SEPTIC TANK PUMPING FREQUENCY IN YEARS						
Tank Size (gallons)	Household Size (number of people)					
	1	2	3	4	5	6
500	6	3	2	1	1	0.5
750	9	4	3	2	1.3	1.0
900	11	5	3.5	2	1.7	1.5
1000	12	9	4	3	2.0	1.5
1250	15	8	5	3.5	2.5	2.0
1500	19	9	6	4	3	2.5
1750	22	11	7	5.0	4	3
2000	25	12	8	6	4.5	3.5
2250	29	14	9	7	5	4
2500	32	16	10	8	6	5

## **Individual Wastewater Systems**

Individual treatment systems collect, treat, and disperse wastewater from an individual property and are associated with low-density communities and developments, such as rural residential and small commercial developments. Individual systems generally consist of one or more treatment devices (e.g., septic tank, fixed film treatment unit) and a subsurface dispersal system.

The operation and maintenance requirements of an individual system can vary greatly depending on the type of system. For example, mechanical systems, such as activated sludge-based units, require servicing three to four times a year, while conventional systems need service or pumping every three to seven years, depending on occupancy and use.

## **Conventional Systems**

Conventional “septic” systems are the most widely used wastewater treatment system. These systems are simple to operate and, when properly designed, constructed, and maintained, do an excellent job of removing pollutants from wastewater. In most communities, the operation and maintenance of conventional systems is the responsibility of the homeowner.

Conventional systems require periodic pumping to remove the solids, fats, oils, and grease that accumulate in the septic tank.

When a system is poorly maintained and not pumped out on a regular basis, sludge (solid material) can build up inside the tank and may ultimately clog the absorption field, making the system unusable.

Most conventional system designs now include risers that allow access to inspect tanks and determine pumping needs.

## Septic System Evaluation Guideline

A septic system evaluation should be conducted as soon as the property is placed on the market so that necessary repairs can be made to the system. The evaluation should be completed before the sale is final.

### At a minimum, an evaluation should examine these issues:

- The location, age, size and original design of the septic system.
- The soil conditions, drainage, seasonal water table and flooding possibilities on the site where the septic system is located.
- Review system maintenance and pumping records.
- The condition of the plumbing fixtures and their layout to determine whether structural changes have been made to the plumbing that would increase flow to the septic system above the capacity.
- The date the septic tank was last pumped.
- The sludge level in the septic tank.
- The condition of the absorption field.
- Evidence of liquid waste reaching the soil surface, draining toward nearby lakes and streams, or clogging the soil and gravel beneath the field. This usually requires digging up a small portion of the field.
- Look for evidence that heavy equipment has been on the drain field, causing compaction and possible damage.

### Enhanced Treatment Systems

Several wastewater alternative technologies have proven to be effective in situations where conventional systems are not appropriate. These systems fall into three broad categories:

#### Material Replacement

Technologies that replace one component of the conventional system with a component manufactured from a different material.

#### Conventional System Modification

Technologies that enhance or otherwise improve conventional operating or treatment performance.

#### Enhanced Wastewater Treatment

Advanced or innovative technologies that provide a higher level of treatment beyond conventional systems. Generally, these systems have mechanical or moving parts that require periodic operation and maintenance, inspections, and eventual replacement. Enhanced wastewater treatment systems are more complex than conventional systems and require greater oversight to keep all aspects of the treatment process in balance.

Some of the more common enhanced system technologies in use today include:

- ✓ Activated Sludge-Based Aerobic Treatment Units
- ✓ Denitrification Systems
- ✓ Fixed Activate Sludge Treatment
- ✓ Recirculating Media Filter
- ✓ Sequencing Batch Reactors
- ✓ Septic Tank Filters or Screens
- ✓ Gravel less Leach fields



## Perforated Pipe

Perforated pipe is laid in the bottom of upslope trenches excavated into the restrictive horizon. A durable, porous medium is placed around the piping and up to a level above the estimated seasonally high-saturated zone.

The porous medium intercepts the ground water and conveys it to the drainage pipe. To provide an outfall for the drain, one or both ends of the pipe are extended downslope to a point where it intercepts the ground surface. When drainage enhancements are used, the outlet and boundary conditions must be carefully evaluated to protect local water quality.

The drain should avoid capture of the SWIS percolate plume and ground water infiltrating from below the SWIS or near the end of the drain. A separation distance between the SWIS and the drain that is sufficient to prevent percolate from the SWIS from entering the drain should be maintained.

The vertical distance between the bottom of the SWIS and the drain and soil permeability characteristics should determine this distance.

As the vertical distance increases and the permeability decreases, the necessary separation distance increases.



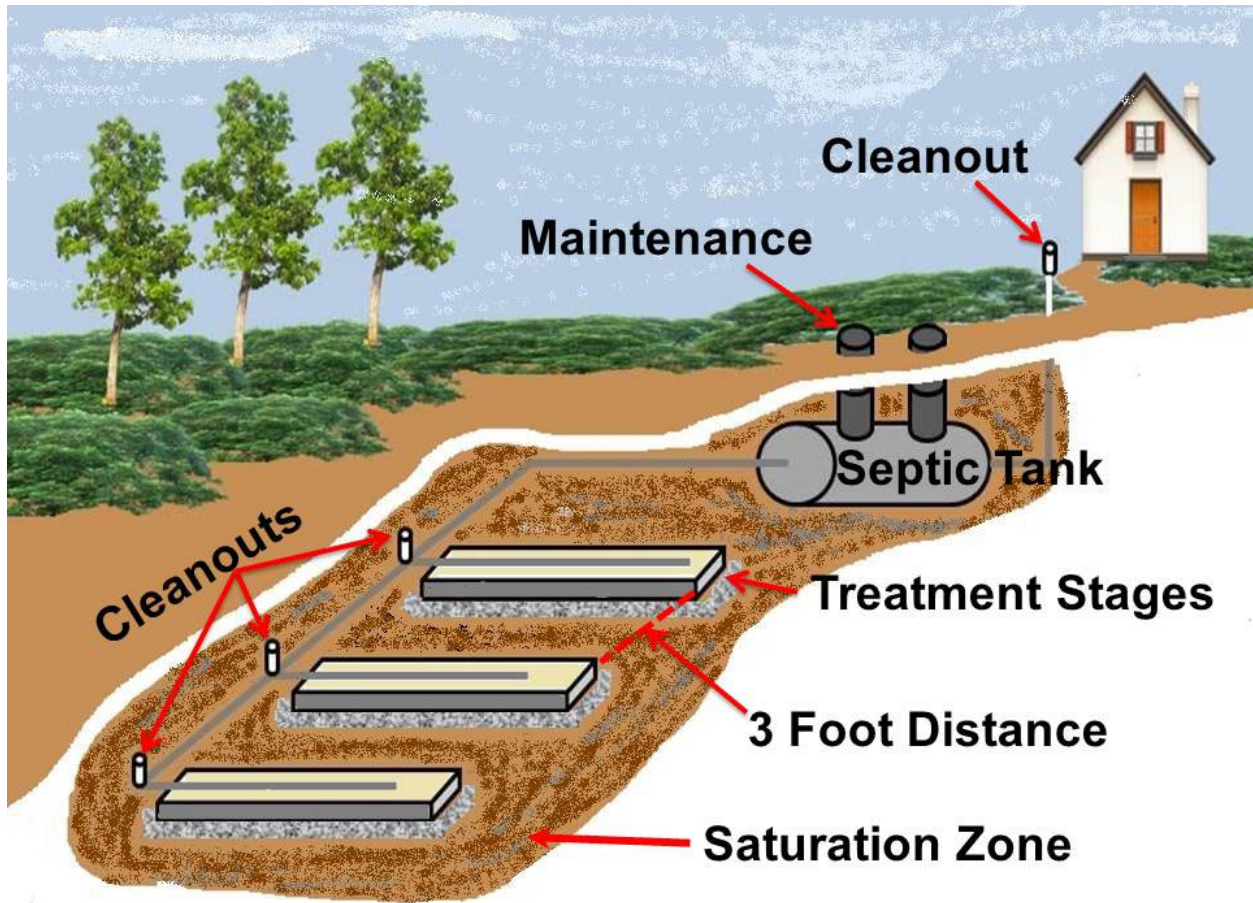

A 10-foot separation is used for most applications. Also, if both ends of the drain cannot be extended to the ground surface, the upslope end should be extended some distance along the surface contour beyond the end of the SWIS.

If not done, ground water that seeps around the end of the drain can render the drain ineffective. Similar cautions should be observed when designing and locating outlet locations for commercial systems on flat sites.

The design of a curtain drain is based on the permeability of the soil in the saturated zone, the size of the area upslope of the SWIS that contributes water to the saturated zone, the gradient of the drainage pipe, and a suitable outlet configuration.

If the saturated hydraulic conductivity is low and the drainable porosity (the percentage of pore space drained when the soil is at field capacity) is small, even effectively designed curtain drains might have limited effect on soil wetness conditions.

Penninger et al. (1998) illustrated this at a site with a silty clay loam soil at field capacity that became completely re-saturated with as little as 1-inch of precipitation. For further design guidance, refer to the U.S. Department of Agriculture's Drainage of Agricultural Land (USDA, 1973).

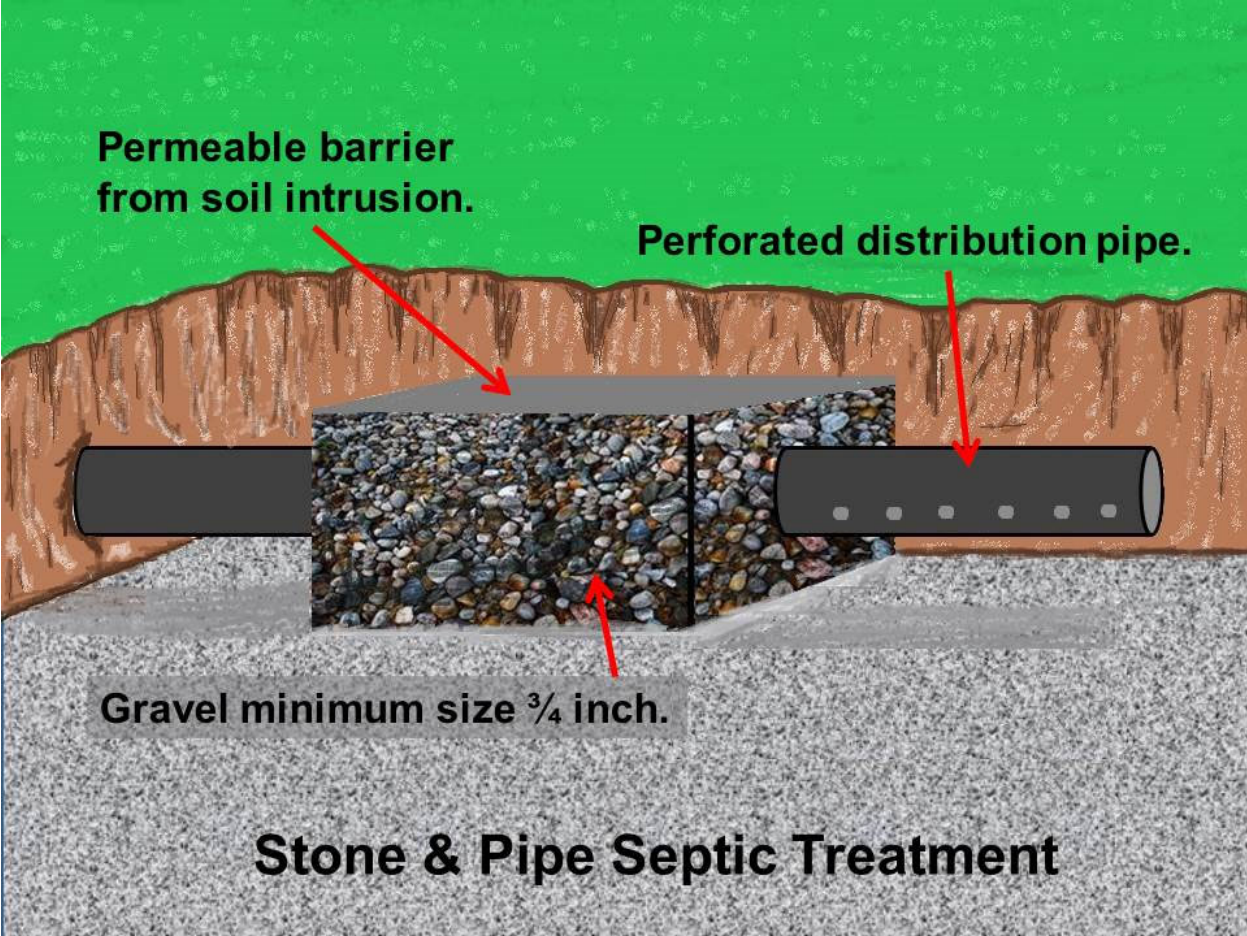

## Inspections and Maintenance Requirements

The primary function of the septic tank is to settle out solids from the wastewater.

Solids are allowed to settle out by holding the sewage in a quiet environment within the tank. Typically, 24 to 48 hours of settling is required. A four-bedroom home might have a daily flow of 480 gallons per day (assuming 120 gallons per bedroom per day). In a 1,000-gallon tank, this provides two days for solids to settle.

Nevertheless, as the solids build up, there is less room in the tank for the liquid and thus less settling time. The accepted maximum level of solids in the tank is 1/3 of the liquid depth. Any more than this and the tank is overdue for pumping. Having these solids removed, is a critical component of how well the septic system, as a whole, will function.

When a septic tank is inspected for solids accumulation, a certified inspector will use an instrument called a "Sludge Judge®" or similar device to determine the amount of solids in the tank. There are other products available to perform this task, and one is not recommended above another. The Sludge Judge® is a long, hollow, usually clear plastic pole marked in 1-foot increments.

The bottom end of the instrument has a stopper on it that allows the wastewater and solids to enter the pole, but not leave, allowing a visual reference to what is inside the tank. The inspector inserts the pole into the tank until it touches the bottom.

The instrument is then removed, and solids and liquid levels can be determined. This allows the inspector to determine if it is time for the tank to be pumped. A certified inspector will also check the other components within the tank. Septic tanks can come in a variety of shapes, sizes, and material.

Each of these different types of tanks has different components, which need to be inspected. The most important issue with any tank, whether it is concrete, plastic, or fiberglass, is that it must be watertight. Watertightness is important for two reasons: wastewater must be kept in the tank so that it does not contaminate the groundwater, and groundwater must be kept out of the tank so that the tank is not over filled. The only way to make sure a tank is watertight is to have it pumped and visually inspect the inside of the tank.

Septic tanks are constructed from different materials, as mentioned earlier, usually concrete, plastic, or fiberglass. In each of these, a quiet environment is necessary for solids settling and is accomplished by using one of two methods: baffles or tees.

Septic tanks can have either of these components and regardless of which one, they must be inspected. The purpose of baffles and tees is to slow the wastewater coming into the septic tank to ensure the proper environment for solids to settle.

A certified inspector will check to make sure that tees or baffles are properly connected to both the inlet and outlet pipes of the tank. Baffles are made of the same material as the tank and are usually fitted during manufacturing of the tank. In a concrete tank, the concrete baffle must be checked for corrosion and cracks. If it is determined by the inspector that a concrete baffle is corroded or missing, instead of replacing the tank, a tee will be fitted to the tank. A tee is a pipe fitting that is typically made of plastic, like the inlet and outlet pipes.

## **SWIS Designs**

There are several different designs for SWISs. They include trenches, beds, seepage pits, at grade systems, and mounds. SWIS applications differ in their geometry and location in the soil profile. Trenches have a large length-to-width ratio, while beds have a wide, rectangular or square geometry.

Seepage pits are deep, circular excavations that rely almost completely on sidewall infiltration. Seepage pits are no longer permitted in many jurisdictions because their depth and relatively small horizontal profile create a greater point-source pollutant loading potential to ground water than other geometries. Because of these shortcomings, seepage pits are not recommended in this manual.

Infiltration surfaces may be created in natural soil or imported fill material. Most traditional systems are constructed below ground surface in natural soil. In some instances, a restrictive horizon above a more permeable horizon may be removed and the excavation filled with suitable porous material in which to construct the infiltration surface (Hinson et al., 1994). Infiltration surfaces may be constructed at the ground surface ("at-grades") or elevated in imported fill material above the natural soil surface ("mounds").

An important difference between infiltration surfaces constructed in natural soil and those constructed in fill material is that a secondary infiltrative surface (which must be considered in design) is created at the fill/natural soil interface. Despite the differences between the types of SWISs, the mechanisms of treatment and dispersal are similar.

## **Typical Applications**

Subsurface wastewater infiltration systems are passive, effective, and inexpensive treatment systems because the assimilative capacity of many soils can transform and recycle most pollutants found in domestic and commercial wastewaters.

SWISs are the treatment method of choice in rural, unsewered areas. Where point discharges to surface waters are not permitted, SWISs offer an alternative if ground water is not closely interconnected with surface water. Soil characteristics, lot size, and the proximity of sensitive water resources affect the use of SWISs. Local codes should be consulted for special requirements, restrictions, and other relevant information.

## **Typical Performance**

Results from numerous studies have shown that SWISs achieve high removal rates for most wastewater pollutants of concern with the notable exception of nitrogen. Biochemical oxygen demand, suspended solids, fecal indicators, and surfactants are effectively removed within 2 to 5 feet of unsaturated, aerobic soil.

Phosphorus and metals are removed through adsorption, ion exchange, and precipitation reactions. However, the retention capacity of the soil is finite and varies with soil mineralogy, organic content, pH, redox potential, and cation exchange capacity. The fate of viruses and toxic organic compounds has not been well-documented (Tomson et al., 1984). Field and laboratory studies suggest that the soil is quite effective in removing viruses, but some types of viruses apparently are able to leach from SWISs to the ground water.

Fine-textured soils, low hydraulic loadings, aerobic subsoils, and high temperatures favor destruction of viruses and toxic organics.

## Two Types of Septic Inspections

There are two main types of inspections of conventional septic systems: a “visual” inspection and a “full” inspection (where the tank is pumped out at the same time).

### Primary -Visual Inspections

This is the type of inspection usually performed by home inspectors. Occasionally, a septic company may provide this type of inspection if the home buyer is not concerned about the septic system and is only having one done to satisfy the mortgage company (although not all loans will accept this type of inspection).

A visual inspection is a very limited inspection: it consists of running water in the house and flushing commodes. The tank may or may not be located, but it is usually not opened or checked unless the access lid is already exposed.

Therefore, as long as there is no backup in the plumbing and no water surfacing over the absorption area, one has to assume the system is functioning properly. This does not mean everything is functioning as it should — it just means the toilets flush.

### Visual Inspections are Risky

A visual inspection is risky for the buyer, because they do not know what you cannot see. Here are a few examples of problems systems can have that the inspector would never know if only a visual inspection were performed:

- Leaking tank
- Overfull tank
- Roots
- Backflow
- Location (under deck, room addition, etc.)
- If baffles are in place
- If the dividing wall is secure
- Corrosion
- Thickness of sludge in the tank
- Size of tank or Inadequately sized tank

A need for repairs caused by a major problem with the system may mean having to install an entirely new system (due to regulation changes). Depending on the type of system required for that property, new systems can range from \$7,000 to \$15,000 on average, with some properties up to \$25,000 or more due to small lots, hills and access, etc. If these problems are not discovered until after the house has sold, the new homeowner may find themselves having to foot the bill for repairs of a new septic system.

### Variations on Visual Inspections

An inspector may perform a variation of a visual inspection called a “dye test,” in which he or she adds dye into the plumbing via the faucet or commode. The theory is that if any of the dye is seen in the yard, then there is a problem.

Unlike the public collection system, adding dye is often unnecessary; no water should ever surface over any portion of the system, no matter its color. However, many septic operators use dye as a sales tool.

## **Maintenance Inspections**

The inspection should be performed by a certified inspector, usually a qualified private contractor or member of the local health department. An inspection can be arranged by contacting your local health department. The health department will either be able to complete the inspection, or refer you to the appropriate wastewater professional to do the job. Some health departments may charge a fee to complete an inspection. The first thing to be done in an inspection is to determine the location of the septic tank.

Sometimes a sketch of the system is included with the original septic system permit and can be referred to in locating the septic tank. If no sketch is available, a probe is most often used to locate your septic tank. In some instances, when a probe cannot locate the tank, a radio transmitter may be used. The transmitter is about the size of a small bottle of aspirin, and is flushed down the toilet. A receiver is then used to follow the transmitter and locate the septic tank. The transmitter can be retrieved once the tank is located and opened.

Once the tank is located, it will need to be uncovered. In some cases, the homeowner is required to locate and uncover the septic tank prior to the inspector arriving. This can reduce costs of the inspection if a fee is being charged for system inspection. It also reduces the time needed for the inspection to take place. Once the tank is uncovered and opened, inspection of the inside of the tank and its components will begin.

Maintenance inspections are gaining appeal as a management tool to assess the condition of systems and determine pumping or other O&M needs. In some cases, this is a strictly voluntary program, while in other cases; communities have elected to mandate pumping based on third party inspections. Following inspection, the system owner should be notified of any needed corrections and assigned a deadline to furnish acceptable proof that the corrections have been made. Acceptable proof is usually a certification by the contractor listing the types and dates of corrections made and final inspection. Some local agencies have adopted a sewage management program that requires the annual inspection of systems with newly issued or modified permits and proof of septic tank pumping for all systems (old and new).

Other agencies have designated certain geographical areas (such as aquifer or shoreline protection zones) as being subject to annual system inspections and/or routine tank pumping.

Operation and maintenance inspection programs are usually coupled with a mandatory septic tank pumping program. The local agency notifies the system owner when pumping is due. Verification of pumping is provided to the regulating agency. Typical pumping requirements vary from three to five years or more based on the daily sewage flow and individual household wastewater characteristics.

Alternative and enhanced wastewater technologies require additional maintenance and/or ongoing attention. In states and communities where these systems are authorized, performance inspections are mandated in the state code or in the system's operating permit.

For enhanced wastewater systems, a long-term maintenance contract is highly recommended and typically required in state or local regulations, or as a provision of a system's operating permit. In addition, the National Sanitation Foundation (NSF) requires that manufacturers seeking NSF/American National Standards Institute (ANSI) certification of a particular wastewater technology must include the price of maintenance for the first two years in the product's price as

a condition of certification. In response, many manufacturers of wastewater systems now offer maintenance contracts with their products.

In the soil treatment portion of the septic system, bacteria and viruses in the sewage are filtered by the soil and microscopic organisms that occur naturally in the soil. Nutrients are absorbed by soil particles or taken up by plants. These processes only work in unsaturated soil that has air in it. Soil conditions may be saturated near lakes, streams and wetlands, and in areas with seasonal or perched high water tables. In these cases, biological breakdown will be incomplete and nutrients will move much greater distances. Ironically, numerous unsewered communities exist around lakes, where saturated conditions are likely to exist. Originally intended as part time vacation homes, residents now occupy the homes year round, taxing already stressed onsite systems.

Untreated or improperly treated wastewater contains biological contaminants known to cause disease. These contaminants are known as germs or pathogens. Pathogens fall into five main categories: bacteria, viruses, protozoans, fungi and worms. Most of these pathogens use the fecal/oral route to spread disease. Fecal material, including human waste, contains pathogens. The usual method of infection requires you to touch the fecal material with your hands and then transfer it to your mouth, either directly or through food. Pathogens can also contaminate water supplies when the wastewater is allowed to reach the water table before adequate treatment occurs.

Failing septic systems allow excess nutrients to reach nearby lakes and streams, promoting algae and weed growth. Algal blooms and abundant weeds make the lake unpleasant for swimming and boating, and affect water quality for fish and wildlife habitat. As plants die, settle to the bottom, and decompose, they use oxygen that fish need to survive.

Synthetic cleaning products and other chemicals used in the home can be toxic to humans, pets, and wildlife. If allowed to enter a failing septic system, these products may reach groundwater, nearby surface water, or the ground surface.

### **Maintenance of Septic Systems**

A key part of an O&M program is to track the maintenance of systems. The only way to ensure that maintenance contracts are kept in effect and that systems are monitored when required is for the management entity or regulatory authority to have a structured reporting program.

Service providers should report maintenance events and any lapses in maintenance contracts to the management or regulatory authority. This information should be managed in a database to monitor O&M activities and provide a system of accountability. Advances in technology via Web-based remote monitoring or telemetry can also allow multiple system operating parameters (e.g., pump cycles) to be monitored from remote locations around the clock.

### **Tank Pumped**

Another part of the inspection process, after having the tank pumped, is to visually inspect the inlet and outlet pipes for the presence of water entering the tank. It is important that no water is running or plumbing fixtures are being used inside the house during the inspection. If water is running into the tank, it may indicate a leak within the plumbing of the home or infiltration in the inlet pipe. Water draining back into the septic tank from the outlet pipe may indicate a drainfield problem. If that is occurring, the drainfield may be clogged and require further inspection.

### **Effluent Filter**

Another septic tank component that needs to be inspected, if in use, is the effluent filter. These filters are located on the outlet side of the tank, in the outlet tee. The filter needs to be maintained as well, so as not to allow solids to carry over into the drainfield. Maintenance of these filters consists of pulling the filter and hosing the contents back into the septic tank. Another item to consider is the use of “manhole” risers.

These are plastic risers that fit over the “manhole(s)” of a septic tank and are usually installed to come right to ground level. The advantages to having risers is that for future inspections, less excavation will be needed, and it is much easier to locate and access the septic tank. The inspector will check the riser lids for cracks and ensure that the lids are secure so that unauthorized access cannot be gained. It is important to remember that proper operation and maintenance of your septic system includes routine inspections of your system.

Routine inspections are typically different from a property transfer inspection. Property transfer inspections may not be as detailed and may not look at the entire system. Routine inspections are necessary to the health of your onsite system.

### **Reporting and Monitoring State and Local Examples**

The Barnstable County Department of Health in Rhode Island began to use its system database in 2005 to track required services (monitoring, inspections) and O&M contract renewal as required under maintenance contracts. If a component is not inspected on schedule, a notification appears in the service schedule summary.

Homeowners in Hamilton County, Ohio, contract with manufacturers and local plumbers to maintain home aeration wastewater treatment systems. Managed by the county, all of the system locations are recorded using a geographic information system (GIS) tied to a regional GIS that serves the entire Cincinnati Metropolitan Area.

### **Septic Tank Operation and Maintenance**

The septic tank is a passive treatment unit that typically requires little operator intervention. Regular inspections, septage pumping, and periodic cleaning of the effluent filter or screen are the only operation and maintenance requirements.

Commercially available microbiological and enzyme additives are promoted to reduce sludge and scum accumulations in septic tanks. They are not necessary for the septic tank to function properly when treating domestic wastewaters. Results from studies to evaluate their effectiveness have failed to prove their cost effectiveness for residential application. For most products, concentrations of suspended solids and BOD in the septic tank effluent increase upon their use, posing a threat to SWIS performance. No additive made up of organic solvents or strong alkali chemicals should be used because they pose a potential threat to soil structure and ground water.

### **Septic Tank Inspections**

Inspections are performed to observe sludge and scum accumulations, structural soundness, watertightness, and condition of the inlet and outlet baffles and screens.

**(Warning:** In performing inspections or other maintenance, the tank should not be entered. The septic tank is a confined space and entering can be extremely hazardous because of toxic gases and/or insufficient oxygen.)



## **Sludge and Scum Accumulations**

As wastewater passes through and is partially treated in the septic tank over the years, the layers of floatable material (scum) and settleable material (sludge) increase in thickness and gradually reduce the amount of space available for clarified wastewater.

If the sludge layer rises to the bottom of the effluent T-pipe, solids can be drawn through the effluent port and transported into the infiltration field, increasing the risk of clogging.

Likewise, if the bottom of the thickening scum layer moves lower than the bottom of the effluent T-pipe, oils and other scum material can be drawn into the piping that discharges to the infiltration field. Various devices are commercially available to measure sludge and scum depths. The scum layer should not extend above the top or below the bottom of either the inlet or outlet tees. The top of the sludge layer should be at least 1 foot below the bottom of either tee or baffle. Usually, the sludge depth is greatest below the inlet baffle.

The scum layer bottom must not be less than 3 inches above the bottom of the outlet tee or baffle. If any of these conditions are present, there is a risk that wastewater solids will plug the tank inlet or be carried out in the tank effluent and begin to clog the SWIS.

### **Structural Soundness and Watertightness**

Structural soundness and watertightness are best observed after the septage has been pumped from the tank. The interior tank surfaces should be inspected for deterioration, such as pitting, spalling, delamination, and so forth and for cracks and holes. The presence of roots, for example, indicates tank cracks or open joints. These observations should be made with a mirror and bright light. Watertightness can be checked by observing the liquid level (before pumping), observing all joints for seeping water or roots, and listening for running or dripping water.

Before pumping, the liquid level of the tank should be at the outlet invert level. If the liquid level is below the outlet invert, exfiltration is occurring. If it is above, the outlet is obstructed or the SWIS is flooded. A constant trickle from the inlet is an indication that plumbing fixtures in the building are leaking and need to be inspected.

### **Baffles and Screens**

The baffles should be observed to confirm that they are in the proper position, secured well to the piping or tank wall, clear of debris, and not cracked or broken. If an effluent screen is fitted to the outlet baffle, it should be removed, cleaned, inspected for irregularities, and replaced. Note that effluent screens should not be removed until the tank has been pumped or the outlet is first plugged.

### **Septic Tank Pumping**

Tanks should be pumped when sludge and scum accumulations exceed 30 percent of the tank volume or are encroaching on the inlet and outlet baffle entrances. Periodic pumping of septic tanks is recommended to ensure proper system performance and reduce the risk of hydraulic failure.

If systems are not inspected, septic tanks should be pumped every 3 to 5 years depending on the size of the tank, the number of building occupants, and household appliances and habits.

Commercial systems should be inspected and/or pumped more frequently, typically annually. There is a system available that provides continuous monitoring and data storage of changes in the sludge depth, scum or grease layer thickness, liquid level, and temperature in the tank.

Accumulated sludge and scum material stored in the tank should be removed by a certified, licensed, or trained service provider and reused or disposed of in accordance with applicable federal, state, and local codes.

The most significant documented threats to ground water quality from SWISs are nitrates. Wastewater nitrogen is nearly completely nitrified below properly operating SWISs.

Because nitrate is highly soluble and environments favoring denitrification in subsoil are limited, little removal occurs. Chlorides also leach readily to ground water because they, too, are highly soluble and are nonreactive in soil.

Dispersion of SWIS percolate in the ground water is often minimal because most ground water flow is laminar. The percolate can remain for several hundred feet as a distinct plume in which the solute concentrations remain above ambient ground water concentrations (Robertson et al., 1989, Shaw and Turyk, 1994).

#### **Groundwater Plume**

The plume descends in the ground water as the ground water is recharged from the surface, but the amount of dispersion of the plume can be variable. Thus, drinking water wells some distance from a SWIS can be threatened if they are directly in the path of a percolate plume.

## Standard Leach Field Septic System Inspection

As the septic system is used, there is an accumulation of solids in the tank, which is sometime referred to as sludge. The septic tank removes solids by holding wastewater in the tank for at least 24 hours, allowing the solids to settle and scum to rise to the top. This is accomplished by a series of baffles inside the tank. Up to 50% of the solids retained in the tank will decompose over time. Effluent water discharges from the tank to perforated drain pipes. From there, it drains to a constructed absorption or leach field

Septic drain fields, also called leach fields or leach drains are used to remove contaminants and impurities from the liquid that emerges from the septic tank. A septic tank, the septic drain field, and the associated piping compose a complete septic system. The septic drain field is effective for disposal of organic materials readily catabolized by a microbial ecosystem. The drain field typically consists of an arrangement of trenches containing perforated pipes and porous material (often gravel) covered by a layer of soil to prevent animals and surface runoff from reaching the wastewater distributed within those trenches.

Primary design considerations are hydraulic for the volume of wastewater requiring disposal and catabolic for the long-term biochemical oxygen demand of that wastewater.

Many health departments require a percolation test ("perc" test) to establish suitability of drain field soil to receive septic tank effluent. An engineer or licensed designer may be required to work with the local governing agency to design a system that conforms to these criteria.

Wastewater from toilets is assumed to contain bacteria and viruses capable of causing disease.

Disinfection methods used prior to surface disposal of municipal sewage cannot be used with septic tanks because disinfection would prevent wastewater treatment by killing the septic tank and soil ecosystems catabolizing the putrescible contents of the wastewater. A properly functioning drain field holds and deactivates pathogens before they leave the drain field soil.

The goal of percolation testing is to ensure the soil is permeable enough for septic tank effluent to percolate away from the drain field, but fine grained enough to filter out pathogenic bacteria and viruses before they travel far enough to reach a water well or surface water supply.

Coarse soils – sand and gravel – can transmit wastewater away from the drain field before pathogens are destroyed. Silt and clay effectively filter out pathogens but allow very limited wastewater flow rates.

Percolation tests measure the rate at which clean water disperses through a disposal trench into the soil. Several factors may reduce observed percolation rates when the drain field receives anoxic septic tank effluent.

Microbial colonies catabolizing soluble organic compounds from the septic tank effluent will adhere to soil particles and reduce the interstitial area available for water flow between soil particles. These colonies tend to form a low-permeability biofilm of gelatinous slime at the soil interface of the disposal trench

Insoluble particles small enough to be carried through the septic tank will accumulate at the soil interface of the disposal trench; non-biodegradable particles like mineral soil from laundry or vegetable washing, or bone and eggshell fragments from garbage disposals will remain to fill interstitial areas formerly available for water flow out of the trench.

Cooking fats or petroleum products emulsified by detergents or dissolved by solvents can flow through prior to anaerobic liquefaction when septic tank volume is too small to offer adequate residence time, and may congeal as a hydrophobic layer on the soil interface of the disposal trench.

Rising groundwater levels may reduce the available hydraulic head (or vertical distance) causing gravitational water flow away from the disposal trench.

Effluent initially flowing downward from the disposal trench ultimately encounters groundwater or impermeable rock or clay requiring a directional shift to horizontal movement away from the drain field.

A certain vertical distance is required between the effluent level in the disposal trench and the water level where the effluent is leaving the drain field for gravitational force to overcome viscous frictional forces resisting flow through porous soil.

Effluent levels in the vicinity of the drain field will appear to rise toward the ground surface to preserve that vertical distance difference if groundwater levels surrounding the drain field approach the level of effluent in the disposal trench.

Frozen ground may seasonally reduce the cross-sectional area available for flow or evaporation.

## Aerobic Treatment Systems Sub-Section

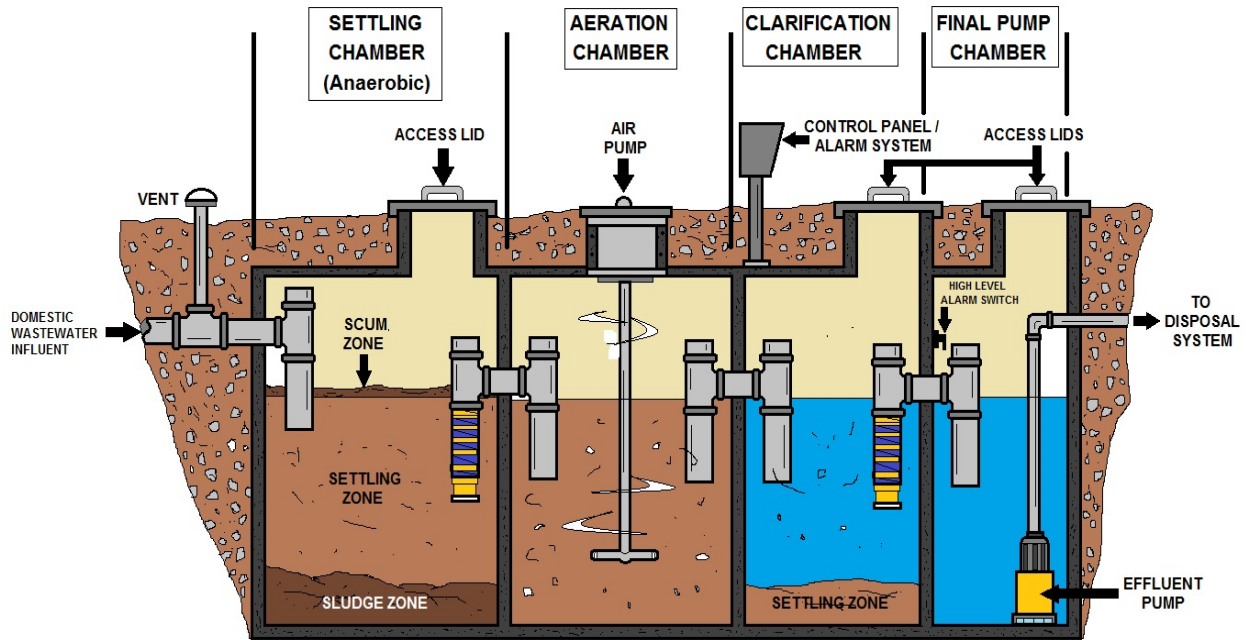

**SEPTIC TANK  
(AEROBIC TREATMENT UNIT TYPE)**



An aerobic treatment system or ATS, often called (incorrectly) an aerobic septic system is a small scale sewage treatment system similar to a septic tank system, but which uses an aerobic process for digestion rather than just the anaerobic process used in septic systems. These systems are commonly found in rural areas where public sewers are not available, and may be used for a single residence or for a small group of homes.

Unlike the traditional septic system, the aerobic treatment system produces a high quality secondary effluent, which can be sterilized and used for surface irrigation. This allows much greater flexibility in the placement of the leach field, as well as cutting the required size of the leach field by as much as half.

**The ATS process generally consists of the following phases:**

**Pre-treatment stage** to remove large solids and other undesirable substances from the wastewater; this stage acts much like a septic system, and an ATS may be added to an existing septic tank to further process the primary effluent.

**Aeration stage**, where the aerobic bacteria digest the biological wastes in the wastewater.

**Settling stage** to allow any undigested solids to settle. This forms a sludge which must be periodically removed from the system.

**Disinfecting stage**, where chlorine or similar disinfectant is mixed with the water, to produce an antiseptic output.

The disinfecting stage is optional, and is used where a sterile effluent is required, such as cases where the effluent is distributed above ground. The disinfectant typically used is tablets of calcium hypochlorite, which are specially made for waste treatment systems.

Unlike the chlorine tablets used in swimming pools, which is stabilized for resistance to breakdown in ultraviolet light, the tablets used in waste treatment systems is intended to break down quickly in sunlight.

Stabilized forms of chlorine will persist after the effluent is dispersed, and can kill off plants in the leach field.

Since the ATS contains a living ecosystem of microbes to digest the waste products in the water, excessive amounts of items such as bleach or antibiotics can damage the ATS environment and reduce treatment effectiveness.

Non-digestible items should also be avoided, as they will build up in the system and require more frequent sludge removal.

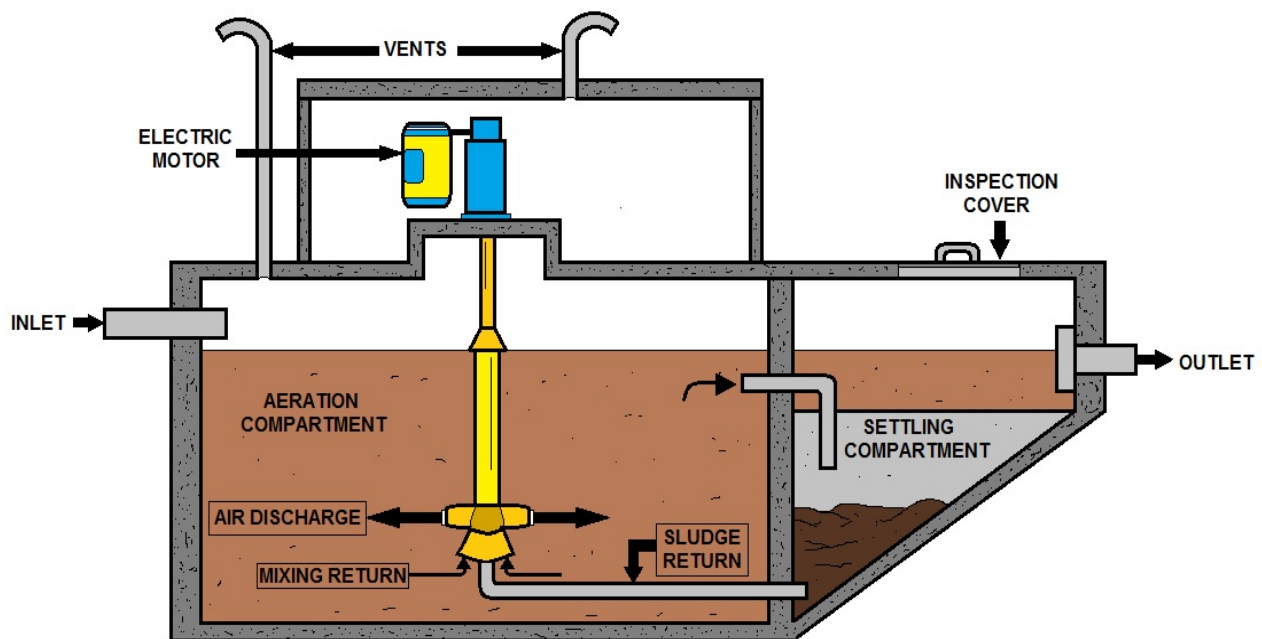

**AEROBIC TREATMENT UNIT (ATU)**

## Clustered Treatment System Maintenance

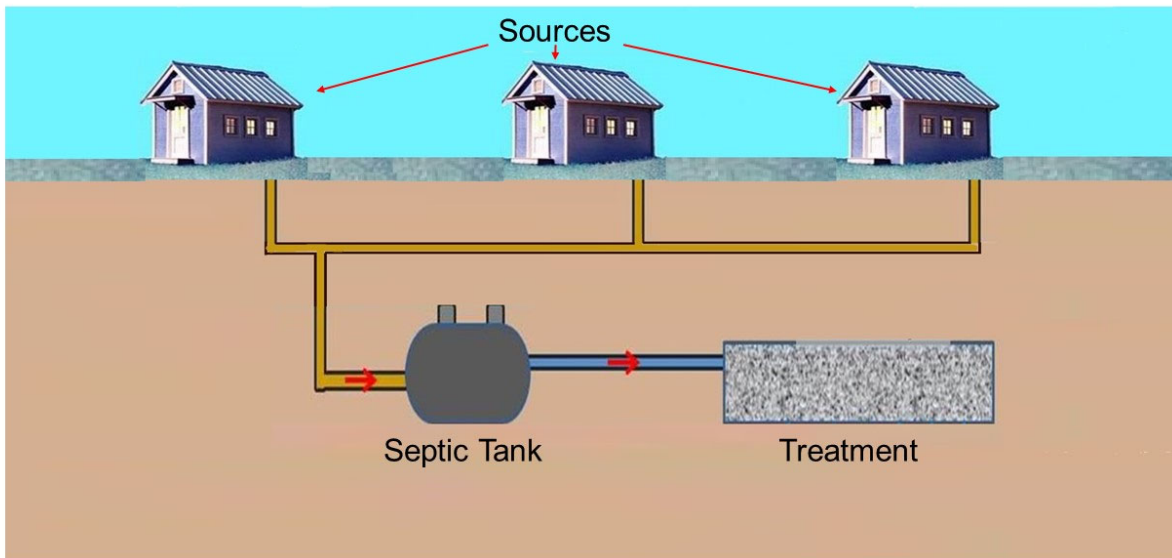

### CLUSTER SEPTIC SEWAGE EXAMPLE

Clustered systems can serve from two to 200 or more homes and/or commercial facilities. Also known as community systems, clustered systems are a treatment option when individual wastewater systems or centralized sewer service are not viable options.

Cluster systems have become an attractive option for many locations, especially in areas like small lakeside communities where a higher level of treatment may be needed.

For example, Minnesota, the “land of 10,000 lakes,” reports that up to 60 percent of the permits processed in recent years are for structures served by clustered wastewater systems.

The operation and maintenance requirements of cluster systems will vary based on the size of the system, the wastewater being treated, and the types of technology used. Various technologies that can be implemented via a cluster system.

They range in scale from a communal septic tank and soil dispersal system serving a dozen homes to a large alternative sewer system connected to a treatment plant that can treat large wastewater flows with a variety of wastewater treatment and dispersal/reuse technologies.

Homes and businesses served by cluster systems may be at varying distances from each other.

Primary treatment of wastewater for cluster systems served by small diameter effluent collection systems (gravity or pumped) is provided at the home or business with a properly designed and sized septic tank.

### **Effluent Filters or Screens**

Effluent filters or screens are used at the outlets of the septic tank or pump tank to prevent larger solids (greater than 1/8") from entering the shared portions of the system. Shut-off, or isolation valves are installed at each property served, and other appropriate valving is used to isolate and service portions of the system as needed.

The use of cluster systems for wastewater service can offer a number of economic and environmental benefits.

#### **Those include:**

- Site disruption, including erosion and sedimentation impacts, can be substantially reduced on each property if only a septic tank and possibly a pump tank is needed, rather than an entire treatment and disposal system constructed for each individual site.
- One treatment and final dispersal system serving multiple properties can offer savings through economies of scale to those served. This is due to reduced initial capital costs per property, as well as lower long term operation and maintenance costs (costs associated with routine maintenance and servicing of one larger system tend to be significantly lower than that of multiple smaller systems).
- Systems providing higher levels of treatment tend to require more maintenance over time, and may have a greater need for on-going care and attention. For environmental conditions for which higher treatment is needed, it may not be reasonable to expect that each home or property will provide adequate care to the system to keep it in good operating condition. Therefore, environmental risks increase with the number of treatment systems serving a given number of properties.
- Individual property owners may not wish to be directly involved with the maintenance and care of their wastewater system. Cluster systems can be operated and maintained by a designated entity with properly trained and licensed personnel.
- Individual lots can safely be smaller if a full individual onsite treatment system is not needed for each. Homes and businesses can be located on lots with steeper slopes and rockier conditions, while reserving a more suitable area in the development/subdivision for the wastewater treatment and dispersal system.



## **Septic Management Considerations**

In the past, state and local wastewater management programs rarely specified O&M requirements for conventional or enhanced wastewater systems. The regulation of system design, construction, and operation was considered to be satisfactory community oversight. However, as more and more systems malfunction and threaten waterways and as more systems include higher maintenance electrical and mechanical components, communities are recognizing the value of O&M requirements.

Many are strengthening programs with a number of tools, including requirements for homeowner service contracts, routine maintenance inspections, revocable operating permits, monitoring, and enhanced reporting and data management that support proper system performance.

### **Education and Outreach**

Public involvement and education is one of the most critical elements in a successful wastewater management program. Engaging stakeholders builds awareness of wastewater management issues and needs and can increase support to develop and implement an effective program. Technical and advisory committees are an effective approach to help review program options and identify O&M proposals. Thurston County, Washington, created a citizen advisory committee in 2003 to help develop an O&M proposal to address problems associated with malfunctioning systems.

The O&M program establishes a more rigorous maintenance and inspection requirement for all treatment systems within the boundaries of the watershed protection area through the use of renewable operational certificates. For systems designated as “high risk,” a dye tracer evaluation is required as a condition of the operational certificate renewal.

Ultimately, it is the actions of the homeowner that will determine the success of any O&M program. Numerous surveys of homeowners have revealed a general lack of knowledge regarding their wastewater systems. Most state and local programs include an education program to promote homeowner awareness. Many have developed guides and fact sheets to inform homeowners about how to maintain and troubleshoot their systems.

Some localities, like Jefferson County in Alabama, mail out reminders to homeowners to have their septic tank checked to see if it is in need of pumping. Others have developed a more rigorous approach of direct technical and financial assistance to homeowners. For example, many Washington counties have used the Washington Water Pollution Control State Revolving Fund’s low-interest loan program to help residents repair and upgrade malfunctioning systems.

### **Training and Certification**

Communities that require inspections of wastewater systems (construction, operations, and maintenance) typically also require using only trained or certified inspectors and service providers. Several states have established certification and licensing programs for inspectors, pumpers, haulers, and other service providers. In addition, some states and jurisdictions have created registries for certified providers to encourage the use of trained professionals.

A small community has many alternatives to evaluate and select from for its wastewater collection and treatment. The choices range from the use of an individual septic tank/lateral field for each home and business, to gravity sewers and treatment plants that are miniatures of those used by larger communities.

Small communities can also consider integrated combinations of more than one method. Centralized, Decentralized, and Onsite A centralized system usually means a central treatment plant handling wastewater collected in gravity sewers with pumping stations as needed.

An onsite system treats the wastewater generated by a single-family home or one business. The wastewater is treated and returned to the environment within the property boundaries of the home or business.

A decentralized system is actually centralized in the sense that it has a central coordinated administration, but may have a common collection system and treatment facility or onsite systems or both. Discharging vs. Non-Discharging A community needs to decide whether they want their system to be discharging or non-discharging.

Discharging systems release the treated wastewater to the ground surface, usually into a ditch or stream.

A discharging system requires a National Pollution Discharge Elimination System (NPDES) permit from the Department of Health and Environment and regular monitoring of the quality of the discharged water. A non-discharging system returns the wastewater to the soil (below surface) and to the air by evaporation or plant transpiration.

Non-discharging lagoons that receive more than 2,500 gallons per day require a State water pollution control permit.

Factors that are considered in making the discharging/non-discharging decision are size of the community (flow), ability of the local soils to absorb the required amount of wastewater, limitations on the stream receiving the water, and ability/desire to operate a moderately complex system.

Discharging systems must use some type of treatment such as a sand filter, aeration system, package plant (pre-engineered mechanical unit), or a set of lagoons designed to be discharging systems, followed by disinfection, if needed.

## Operating Permits

In some cases, renewable operating permits are used to ensure ongoing maintenance of a wastewater system. In areas where operating permits are issued to conventional systems, the permit may specify routine septic tank pumping. On the other hand, in the case of Spokane, Washington, new systems and systems located over the Spokane/Rathdrum Aquifer are tracked and issued a renewable three-year permit by the health district. Inspection and maintenance is required prior to permit renewal.

More complex (enhanced) systems, however, often include maintenance inspections, maintenance contracts, and compliance measures. In the case of a performance-based system, the operating permit may include specific standards that must be maintained along with monitoring and reporting requirements. Ohio adopted O&M regulations in 2004 that authorize the use of operating permits as a legal means to establish O&M requirements and, in some cases, mandatory service contracts. The regulations include a provision that O&M, in accordance with the manufacturer's instructions, shall be met when required as a condition of an operating permit. The O&M rules also require:

- ✓ Increased levels of management related to risk conditions associated with higher sewage treatment system density, complexity, and reliability and location of systems in areas of high risk for surface water or groundwater contamination.
- ✓ Recording of operating permit conditions, service contract requirements, or other O&M management information on property deeds as a means to provide notification upon transfer of property.
- ✓ Utilization of private sector professionals or responsible management entities, or designation of qualified agents to conduct monitoring or other O&M management responsibilities.
- ✓ Inclusion of enhanced O&M management mechanisms such as Web-based reporting, remote telemetry, and use of publicly and privately available database programs to support O&M tracking requirements.
- ✓ Establishment of a household sewage treatment district.

### Renewable Operating Permits for Enhanced Systems

Marin County, California, requires renewable operating permits for enhanced systems. The permits are the basis for verifying the adequacy of a system's performance and their renewal is based on the performance of the system. Failure to undertake any required corrective work may be cause for non-renewal or revocation of the operating permit.

In Monroe County, Florida, state law specifies enhanced nutrient reduction systems to protect the coastal ecosystem. These systems have biennial operating permits, and maintenance contracts and are inspected annually.

Malibu, California, Ordinance 242 adopted in 2001 establishes a renewable operating permit for new and replacement wastewater treatment systems. Inspections from private registered inspectors are required on a regular basis. Operating permits for enhanced systems are good for two years. Permits for conventional systems are good for three years.

Four health districts in the northeastern corner of North Carolina established the Albemarle Septic Management Entity (ASME) to monitor the subsurface drainage of wastewater treatment systems. ASME issues operating permits in accordance with state and local rules.

In addition to conventional systems, two inspections of enhanced systems are conducted each year. ASME has authority to repair a malfunctioning system and bill the owner or place a lien on property for failure to reimburse ASME.

### **Public and Private Management Entities**

Enhanced systems and cluster systems can pose greater risks of mechanical and performance failure than passive conventional systems. Special districts, water/sewer authorities, and public utilities can be an effective option for managing these systems. Private entities can also be authorized to own, operate, and/or maintain an individual or cluster system.

Michigan law provides for a number of institutional options for community wastewater management and the construction of community wastewater treatment systems. For example:

Rural townships can contract for management services from an adjacent community with a preexisting wastewater management entity.

If the county has a county sewage/water district, then local governments contract directly with the county for wastewater management services.

Small communities, townships, and villages can contract with a private company to monitor and maintain individual and community wastewater systems.

Several townships and/or villages can establish a joint authority, such as a sewage district or management district, to share building and management costs.

At least 12 possible institutional variations for wastewater management entities are authorized in North Carolina. Minnesota has several wastewater management districts operating, including two sponsored by local rural electric associations. The utilities subcontract with local installers to perform the twice-a-year O&M service. These utilities have the ability to bill their wastewater customers for O&M as part of their electric bill.

Finally, accountability is an important aspect of administering a private or public management entity. Health departments and state agencies generally retain their authority to approve system designs and issue permits. The public or private management entity conducts inspections, provides maintenance, and executes remediation and repair activities.

### **Aerobic Treatment Units (ATUs)**

A mechanical onsite treatment unit that provides secondary wastewater treatment by mixing air (oxygen) and aerobic and facultative microbes with the wastewater in a sewage tank. In many states, the minimum construction standards require that ATUs comply with NSF Standard 40.

### **Gravity Effluent Distribution Devices**

Divide and/or transport the liquid effluent from a septic tank or ATU to absorption trenches for dispersal into the soil. These devices include distribution boxes, drop boxes, and step-downs.

## Gravity Laterals

A system of trenches excavated along ground contours used to distribute effluent by gravity flow from a septic tank or ATU and apply the effluent to the soil infiltrative surface. Generally, 18-inch deep trenches are used; however, with approval trenches can be up to 30 inches deep.

### Gravity Lateral Systems Include:

- ✓ 4-inch perforated distribution pipe in trenches filled with gravel or tire chips;
- ✓ chamber systems (an open bottom structure, which forms an underground effluent storage cavity over the soil's infiltrative surface);
- ✓ large diameter gravel-less pipe (a filter wrapped corrugated plastic pipe); and
- ✓ 12-inch expanded polystyrene (EPS) bundles (a 4-inch corrugated plastic distribution pipe enclosed in a bundle of EPS)

### Shallow Placed Gravity Laterals

Lateral trenches with the trench bottom 12 to 18 inches deep in natural soil with suitable soil fill material properly installed to provide adequate cover over the system.

### Dosed Gravity Systems

Use siphons or pumps to dose into a gravity distribution device or through a pressure manifold into the ends of gravity lateral trenches. Pressure manifolds can be used to more equally divide effluent between gravity lateral trenches or to proportion effluent to unequal length trenches; however, effluent is still moved along the length of a trench by gravity.

### Lagoons (Wastewater Stabilization Ponds)

Sealed earthen basins, which use natural unaided biological processes to treat wastewater.

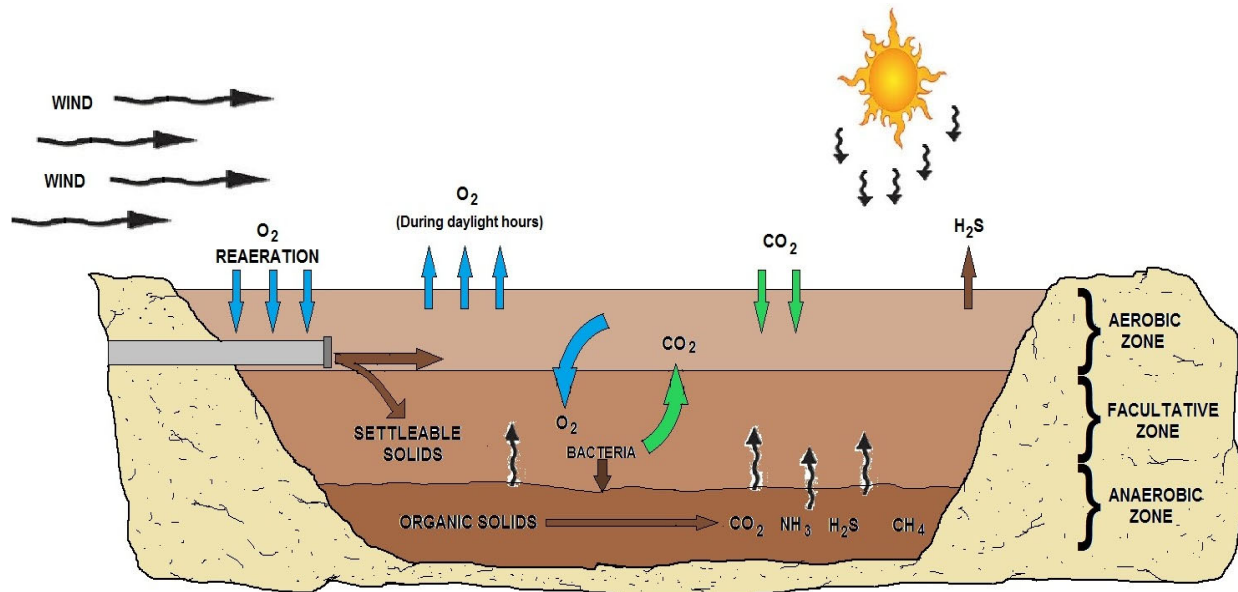

## FACULTATIVE LAGOON

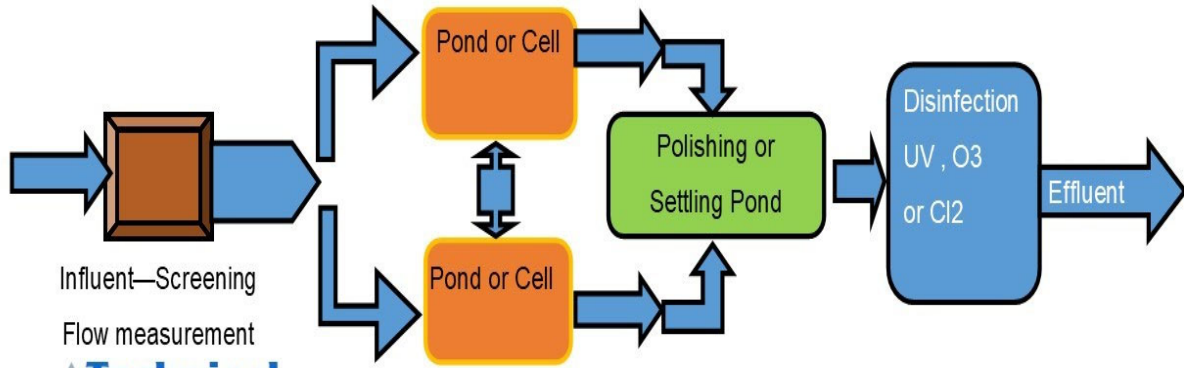

**Simplified Pond Treatment Diagram**

**AEROBIC BUGS IN SECONDARY TREATMENT**

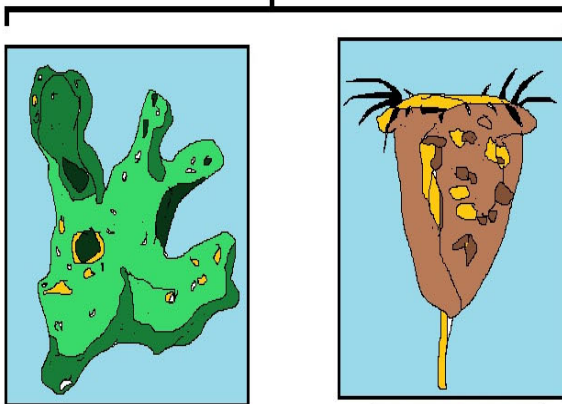

**AMOeba PROTEUS**

HIGH PRESENCE DURING RECOVERY FROM TOXIC DISCHARGE OR LOW OXYGEN LEVELS. THE PRESENCE OF AMOEBAS INDICATE UNSTABLE WASTEWATER ENVIRONMENT AND UNHEALTHY SLUDGE

**VORTICELLA sp.**

A HIGH PRESENCE OF THESE STALKED CILIATES INDICATE STABLE AND MATURE BACTERIAL CLUSTERS AND A HEALTHY SLUDGE

**ANAEROBIC BUGS IN DIGESTERS**

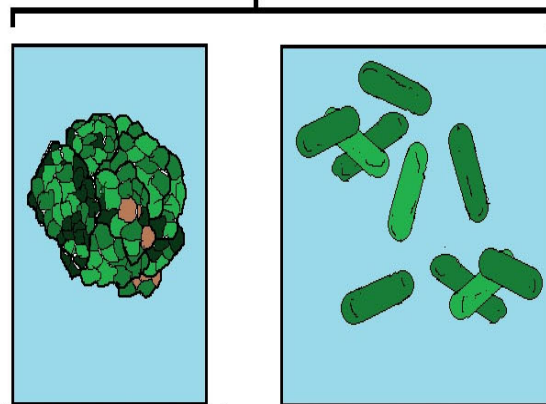

**METHANOSARCINA sp.**

THESE METHANE PRODUCING ORGANISMS LIVE IN DIVERSE ANAEROBIC ENVIRONMENTS

**LACTOBACILLUS sp.**

THESE FERMENTING BACTERIA SECRETE ORGANIC ACIDS AND ENZYMES THAT DEGRADE COMPLEX ORGANIC MATTER INTO SIMPLER METHANE AND CARBON DIOXIDE



**MICROORGANISMS AT WORK IN WASTEWATER TREATMENT**

## Secondary Treatment Sub-Section

*Many times advanced treatment is utilized with or in lieu of Activated Sludge treatment.*

### Ponds and Lagoons

The primary difference between ponds and lagoons is the depth. Ponds are generally shallow, typically 3 to 5 feet, they are often used in small communities to treat domestic waste. The method ponds work to stabilize the waste is that the heavy solids settle to the bottom where it is decomposed by bacteria. The pond's clarity is dependent by the number of ponds in place. We refer to the configuration as singular (in a row) or parallel (side-by-side). Dissolved nutrient materials, such as nitrogen and phosphorus are used by green algae which are microscopic plants floating and living in the water. The algae uses carbon dioxide (CO<sub>2</sub>) and bicarbonate to build body protoplasm. This algae needs nitrogen and phosphorus in their metabolism much as land plants do. Like land plants, they release oxygen and some carbon dioxide as waste products.

### LAGOONS

**Lagoons** are pond-like bodies of water or basins designed to receive, hold, and treat wastewater for a predetermined periods of time. In the lagoon, wastewater is treated through a combination of physical, biological, and chemical processes.



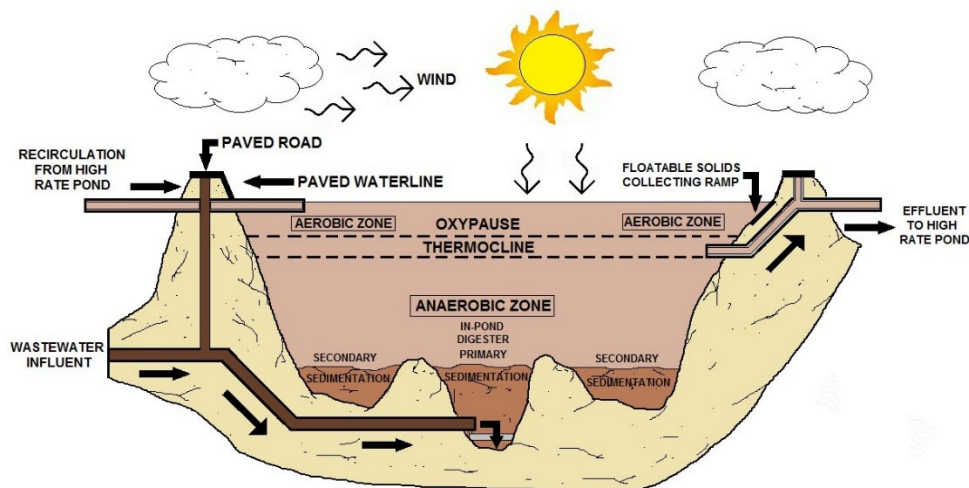

**AEROBIC / ANAEROBIC POND**

The most often used ponds in domestic wastewater treatment are the stabilization pond and facultative lagoon. The stabilization pond is designed to be aerobic throughout its depth and the facultative lagoon will be anaerobic at the bottom and aerobic at the top. Stabilization ponds provide secondary biological treatment and are the most commonly used wastewater pond. Stabilization ponds must be preceded by some form of primary treatment to reduce the solids entering the pond.

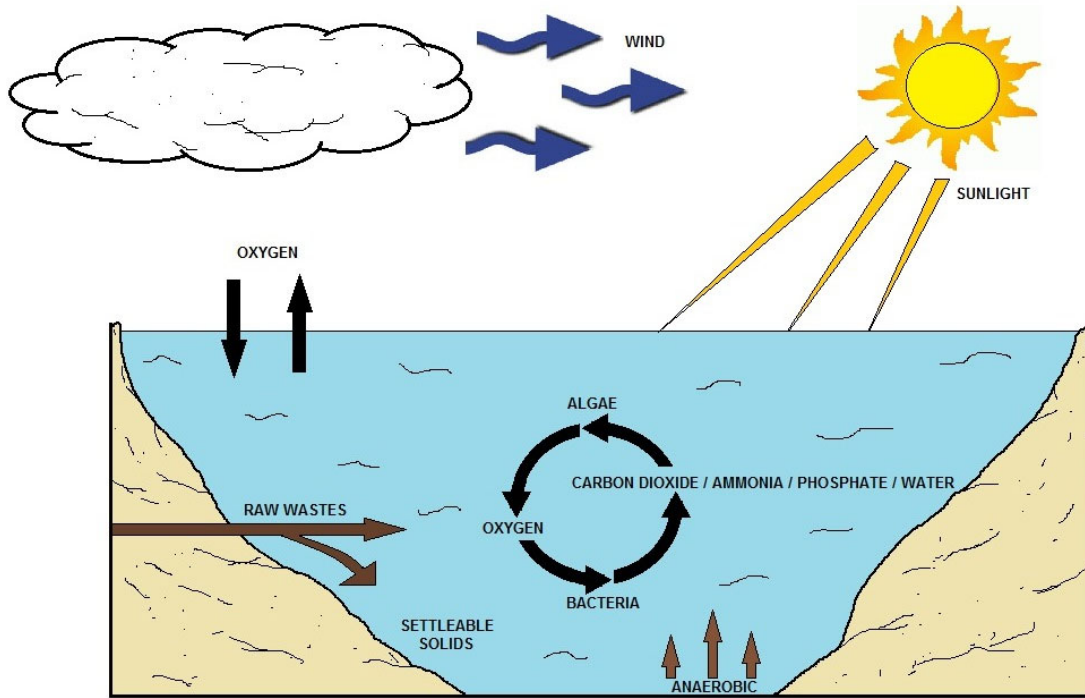

### SECONDARY FACULATIVE POND

Respiration in lakes recycles organic carbon arising from photosynthesis back to inorganic carbon. Prior to this transformation, the organic carbon is potentially available to support secondary production. Generally speaking, ponds rarely are part of the A/S system, but can be a great back-up for overflow conditions.

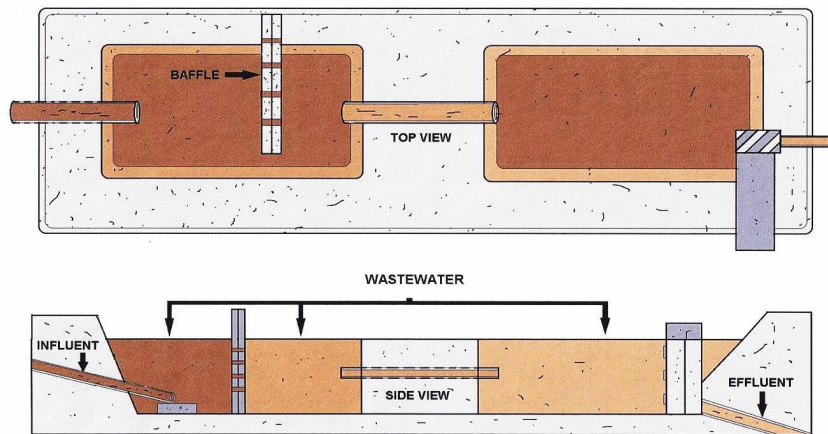

### THREE CELL LAGOON WASTEWATER TREATMENT SYSTEM

The original lagoon system consist of one aerated cell (Basin 1), followed by a non-aerated polishing cell (Basin 2) and a final chlorine contact chamber. This system has a third non-aerated cell (Basin 3) for sludge settling.



## Microorganisms in Lagoons and Activated Sludge

If you feed bugs or maintain bugs to degrade waste, this can be considered part of the A/S. Before we look at the bugs themselves, let us look at eating habits. Have you ever met a person who was a picky eater?

You have people who will put their noses up at some things and others who would eat anything. Predators typically eat from a narrow set of prey, while omnivores and scavengers eat from a broader food selection.

- Swimming and gliding ciliates engulf bacteria or other prey.
- Stalked ciliates attach to the biomass and vortex suspended bacteria into their gullets, while crawlers break bacteria loose from the floc surface.
- Predators feed mostly on stalked and swimming ciliates. The omnivores, such as most rotifers, eat whatever is readily available, while the worms feed on the floc or prey on larger organisms. Microorganisms are directly affected by their treatment environment.
- Changes in food, dissolved oxygen, temperature, pH, total dissolved solids, sludge age, presence of toxins, and other factors create a dynamic environment for the treatment organisms.

Food (organic loading) regulates microorganism numbers, diversity, and species when other factors are not limiting. The relative abundance and occurrence of organisms at different loadings can reveal why some organisms are present in large numbers while others are absent.

The aerobic bacteria that occur are similar to those found in other treatment processes such as in the activated sludge process. Three functional groups occur: freely dispersed, single bacteria; floc-forming bacteria; and filamentous bacteria. All function similarly to oxidize organic carbon (BOD) to produce CO<sub>2</sub> and new bacteria (new sludge).

Many bacterial species that degrade wastes grow as single bacteria dispersed in the wastewater. Although these readily oxidize BOD, they do not settle and hence often leave the system in the effluent as solids (TSS).

These tend to grow in lagoons at high organic loading and low oxygen conditions. More important are the floc-forming bacteria, those that grow in a large aggregate (floc) due to exocellular polymer production (the glycocalyx).



This growth form is important as these flocs degrade BOD and settle at the end of the process, producing a low TSS effluent.

A number of filamentous bacteria occur in lagoons, usually at specific growth environments.

These generally do not cause any operational problems in lagoons, in contrast to activated sludge where filamentous bulking and poor sludge settling is a common problem. Most heterotrophic bacteria have a wide range in environmental tolerance and can function effectively in BOD removal over a wide range in pH and temperature.

Aerobic BOD removal generally proceeds well from pH 6.5 to 9.0 and at temperatures from 3-4°C to 60-70°C (mesophilic bacteria are replaced by thermophilic bacteria at temperatures above 35°C). BOD removal generally declines rapidly below 3-4°C and ceases at 1-2°C.

A very specialized group of bacteria occurs to some extent in lagoons (and other wastewater treatment systems) that can oxidize ammonia via nitrite to nitrate, termed nitrifying bacteria. These bacteria are strict aerobes and require a redox potential of at least +200 mV (Holt et al., 1994).

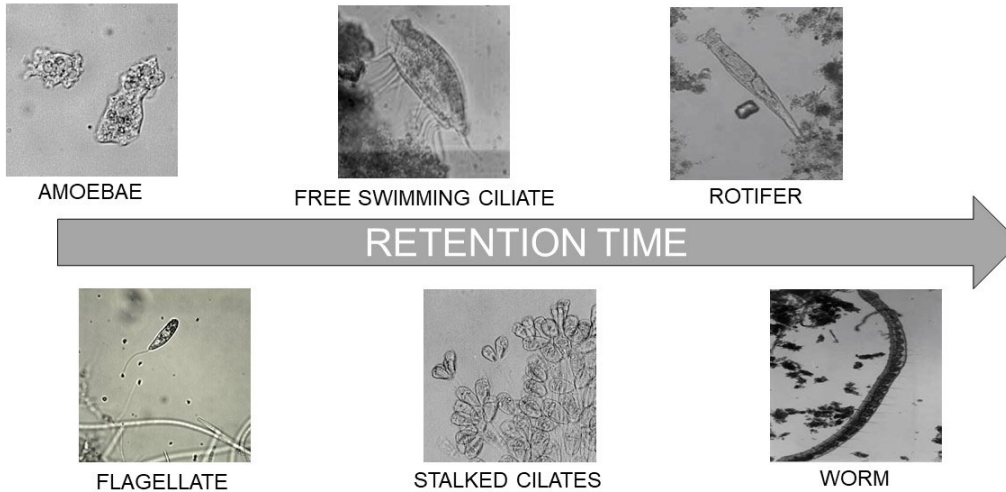

## WASTEWATER INDICATOR ORGANISMS

## Aerated Lagoons

The aerated lagoons are basins, normally excavated in earth and operated without solids recycling into the system. This is the major difference with respect to activated sludge systems.

Two types are the most common: the completely mixed lagoon (also called completely suspended) in which the concentration of solids and dissolved oxygen are maintained fairly uniform and neither the incoming solids nor the biomass of microorganisms settle, and the facultative (aerobic-anaerobic or partially suspended) lagoons. In the facultative lagoons, the power input is reduced causing accumulation of solids in the bottom that undergo anaerobic decomposition, while the upper portions are maintained aerobic. The main operational difference between these lagoons is the power input, which is in the order of 2.5-6 Watts per cubic meter ( $W/m^3$ ) for aerobic lagoons while the requirements for facultative lagoons are of 0.8-1  $W/m^3$ .

Being open to the atmosphere, the lagoons are exposed to low temperatures that can cause reduced biological activity and eventually the formation of ice. This can be partially alleviated by increasing the depth of the basin. These units require a secondary sedimentation unit, which in some cases can be a shallow basin excavated in earth, or conventional settling tanks can be used.

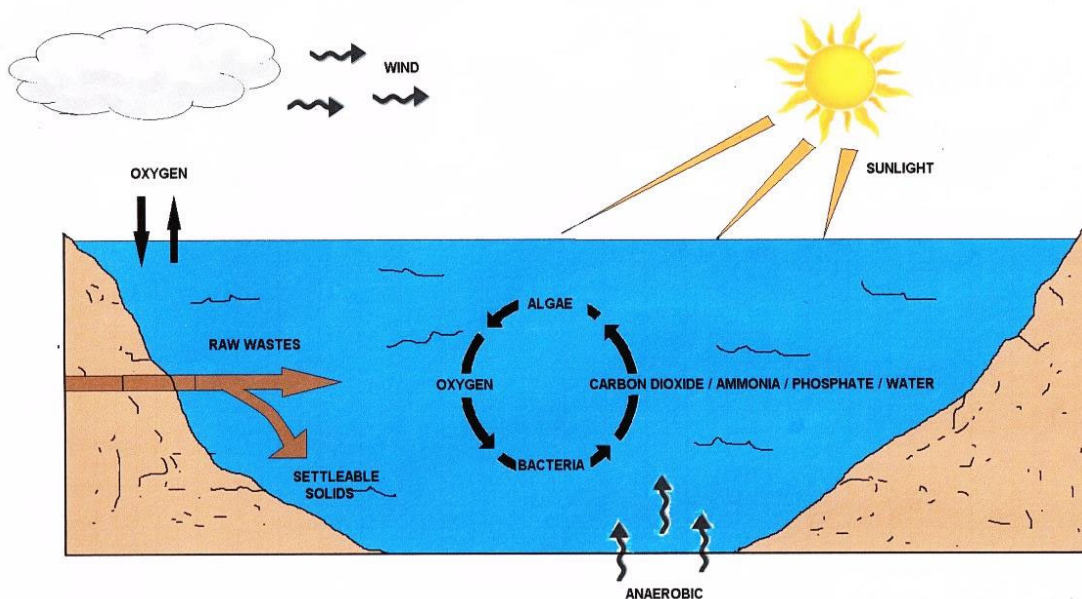

Diagram of facultative aerated lagoon.

If excavated basins are used for settling, care should be taken to provide a residence time long enough for the solids to settle, and there should also be provision for the accumulation of sludge.

There is a very high possibility of offensive odor development due to the decomposition of the settled sludge, and algae might develop in the upper layers contributing to an increased content of suspended solids in the effluent.

Odors can be minimized by using minimum depths of up to 2 m, while algae production is reduced with liquid retention time of less than two days. The solids will also accumulate, all along the aeration basins in the facultative lagoons and even in corners, or between aeration units in the completely mixed lagoon.

These accumulated solids will, on the whole, decompose in the bottom, but since there is always a non-biodegradable fraction, a permanent deposit will build up. Therefore, periodic removal of these accumulated solids becomes necessary. We will cover this in much more detail in a few more pages.

## SUBMERGED DIFFUSED AERATION LAGOON

**Submerged diffused air** is essentially a form of a diffuser grid inside a lagoon. There are two main types of submerged diffused aeration systems for lagoon applications: floating lateral and submerged lateral. Both these systems utilize fine or medium bubble diffusers to provide aeration and mixing to the process water. The diffusers can be suspended slightly above the lagoon floor or may rest on the bottom. Flexible airline or weighted air hose supplies air to the diffuser unit from the air lateral (either floating or submerged).



## SUSPENSION MIXED LAGOON

**Suspension mixed lagoons** flow through activated sludge systems where the effluent has the same composition as the mixed liquor in the lagoon. Typically, the sludge will have a residence time or sludge age of 1 to 5 days. This means that the chemical oxygen demand (COD) removed is relatively little and the effluent is therefore unacceptable for discharge into receiving waters. The primary objective of the lagoon is therefore to act as a biologically assisted flocculator which converts the soluble biodegradable organics in the influent to a biomass which is able to settle as a sludge.



## Algae

Algae are aerobic organisms that are photosynthetic and grow with simple inorganic compounds  $\text{CO}_2$ ,  $\text{NH}_3$ ,  $\text{NO}_3$ , and  $\text{PO}_4$  using light as an energy source. (\*\*Note that algae produce oxygen during the daylight hours and consume oxygen at night.)

Algae are desirable in lagoons as they generate oxygen needed by bacteria for waste stabilization. Three major groups occur in lagoons, based on their chlorophyll type: brown algae (diatoms), green algae, and red algae.

The predominant algal species at any given time is dependent on growth conditions, particularly temperature, organic loading, oxygen status, nutrient availability, and predation pressures. A fourth type of "algae" common in lagoons is the cyano-bacteria or blue-green bacteria.

These organisms grow much as the true algae, with the exception that most species can fix atmospheric nitrogen. Blue-green bacteria often bloom in lagoons and some species produce odorous and toxic by-products.

### Blue-Green Bacteria

Blue-green bacteria appear to be favored by poor growth conditions including high temperature, low light, low nutrient availability (many fix nitrogen) and high predation pressure. Common blue-green bacteria in waste treatment systems include *Aphanothece*, *Microcystis*, *Oscillatoria* and *Anabaena*.

Algae can bloom in lagoons at any time of the year (even under the ice); however, a succession of algae types occurs over the season. There is also a shift in the algal species present in a lagoon through the season, caused by temperature and rotifer and *Daphnia* predation.

Diatoms usually predominate in the wintertime at temperatures  $<60^\circ\text{F}$ . In the early spring, when predation is low and lagoon temperatures increase above  $60^\circ\text{F}$ , green algae such as *Chlorella*, *Chlamydomonas*, and *Euglena* often predominate in waste treatment lagoons.

The predominant green algae change to species with spikes or horns such as *Scenedesmus*, *Micractinium*, and *Ankistrodesmus* later in the season when Rotifers and *Daphnia* are active (these species survive predation better).

Algae grow at warmer temperatures, longer detention time, and when inorganic minerals needed for growth are in excess.

Alkalinity (inorganic carbon) is the only nutrient likely to be limiting for algal growth in lagoons.

Substantial sludge accumulation in a lagoon may become soluble upon warming in the spring, releasing algal growth nutrients and causing an algal bloom. Sludge resolution of nutrients is a major cause of high algal growth in a lagoon, requiring sludge removal from the lagoon for correction.

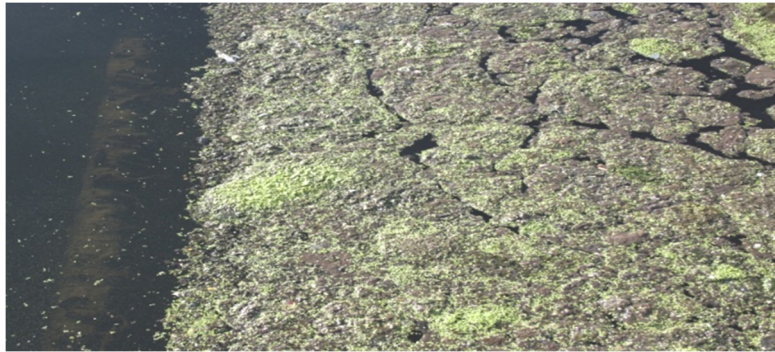

Algae is not a good sign.

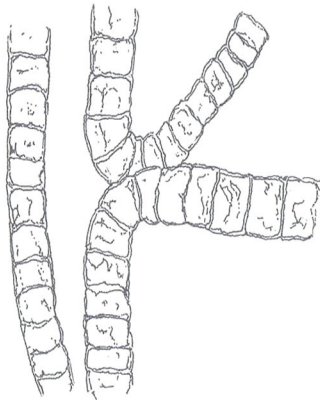

**BLUE-GREEN ALGAE**

ITS CELLS LACK NUCLEI AND ITS PIGMENT IS SCATTERED.  
BLUE-GREEN ALGAE ARE ACTUALLY NOT ALGAE, BUT BACTERIA

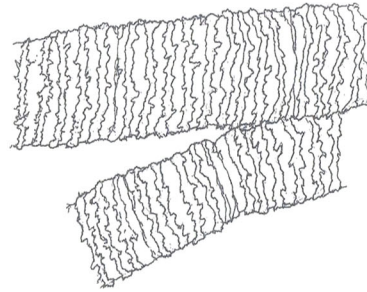

**GREEN ALGAE**

THEIR CELLS HAVE NUCLEI AND PIGMENT IS DISTINCT.  
THEY ARE MOST COMMON ALGAE IN PONDS AND CAN BE MULTICELLULAR

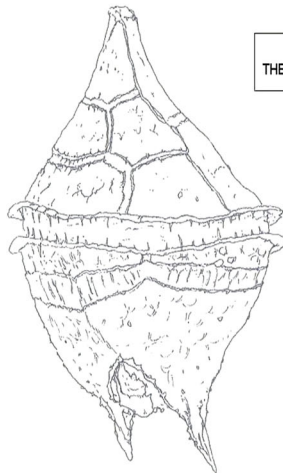

**DINOFLAGELLATES**

THEY HAVE FLAGELLA AND CAN SWIM IN OPEN WATERS  
THEY ARE MICROSCOPIC AND SINGLE-CELLED

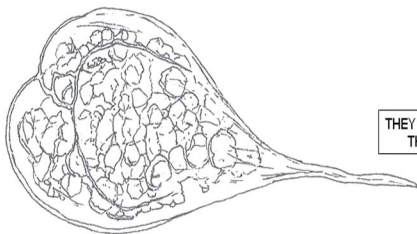

**EUGLENOIDS**

THEY ARE GREEN OR BROWN AND SWIM WITH THEIR FLAGELLUM.  
EASY TO SPOT BECAUSE OF THEIR RED EYE. THEY ARE MICROSCOPIC AND SINGLE CELLED

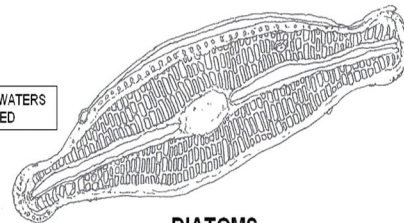

**DIATOMS**

THEY LOOK LIKE TWO SHELLS THAT FIT TOGETHER.  
THEY ARE MICROSCOPIC AND SINGLE CELLED

## More on the Treatment Lagoon

The pH at a treatment lagoon is determined by the various chemical species of alkalinity that are present. The main species present are carbon dioxide ( $\text{CO}_2$ ), bicarbonate ion ( $\text{HCO}_3^-$ ), and carbonate ion ( $\text{CO}_3^{2-}$ ). Alkalinity and pH can affect which species will be present. High amounts of  $\text{CO}_2$  yield a low lagoon pH, while high amounts of  $\text{CO}_3^{2-}$  yield a high lagoon pH.

Bacterial growth on BOD releases  $\text{CO}_2$  which subsequently dissolves in water to yield carbonic acid ( $\text{H}_2\text{CO}_3$ ). This rapidly dissociates to bicarbonate ion, increasing the lagoon alkalinity. Bacterial oxidation of BOD causes a decrease in lagoon pH due to  $\text{CO}_2$  release.

Algal growth in lagoons has the opposite effect on lagoon pH, raising the pH due to algal use for growth of inorganic carbon ( $\text{CO}_2$  and  $\text{HCO}_3^-$ ). Algal growth reduces the lagoon alkalinity which may cause the pH to increase if the lagoon alkalinity (pH buffer capacity) is low.



Algae can grow to such an extent in lagoons (a bloom) that they consume all of the  $\text{CO}_2$  and  $\text{HCO}_3^-$  present for photosynthesis, leaving only carbonate ( $\text{CO}_3^{2-}$ ) as the pH buffering species. This causes the pH of the lagoon to become alkaline. pH values of 9.5 or greater are common in lagoons during algal blooms, which can lead to lagoon effluent pH violations (in most states this is pH = 9). It should be noted that an increase in the lagoon pH caused by algal growth can be beneficial. Natural disinfection of pathogens is enhanced at higher pH.

Phosphorus removal by natural chemical precipitation is greatly enhanced at pH values greater than pH = 8.5. In addition, ammonia stripping to the atmosphere is enhanced at higher pH values ( $\text{NH}_3$  is strippable, not  $\text{NH}_4^+$ ).

### Protozoans and Microinvertebrates

Many higher life forms (animals) develop in lagoons. These include protozoans and microinvertebrates such as rotifers, daphnia, annelids, chironomids (midge larvae), and mosquito larvae (often termed the zooplankton). These organisms play a role in waste purification by feeding on bacteria and algae and promoting flocculation and settling of particulate material.

Protozoans are the most common higher life forms in lagoons with about 250 species identified in lagoons to date (Curds, 1992). Rotifers and daphnia are particularly important in controlling algal overgrowth and these often "bloom" when algal concentrations are high. These microinvertebrates are relatively slow growing and generally only occur in systems with a detention time of >10 days. Mosquitoes grow in lagoons where shoreline vegetation is not removed, possibly causing a nuisance and public health problem.

*Culex tarsalis*, mosquito, the vector of Western Equine Encephalitis in the western U.S., grows well in wastewater lagoons (USEPA, 1983). The requirement for a minimum lagoon bank slope and removal of shoreline vegetation by most regulatory agencies is based on the public health need to reduce mosquito vectors.

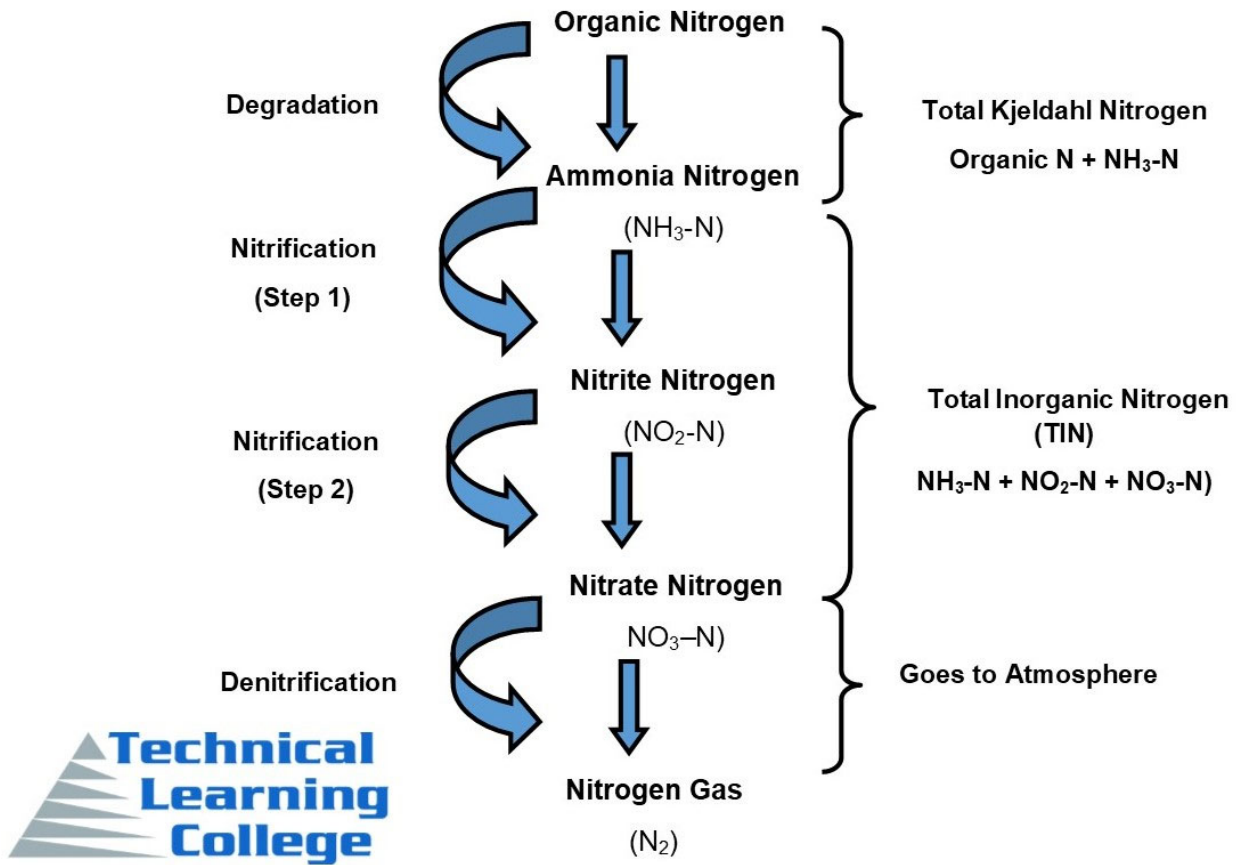

**NITROGEN SPECIES IN WASTEWATER**



## Impacts of Effluent on Groundwater

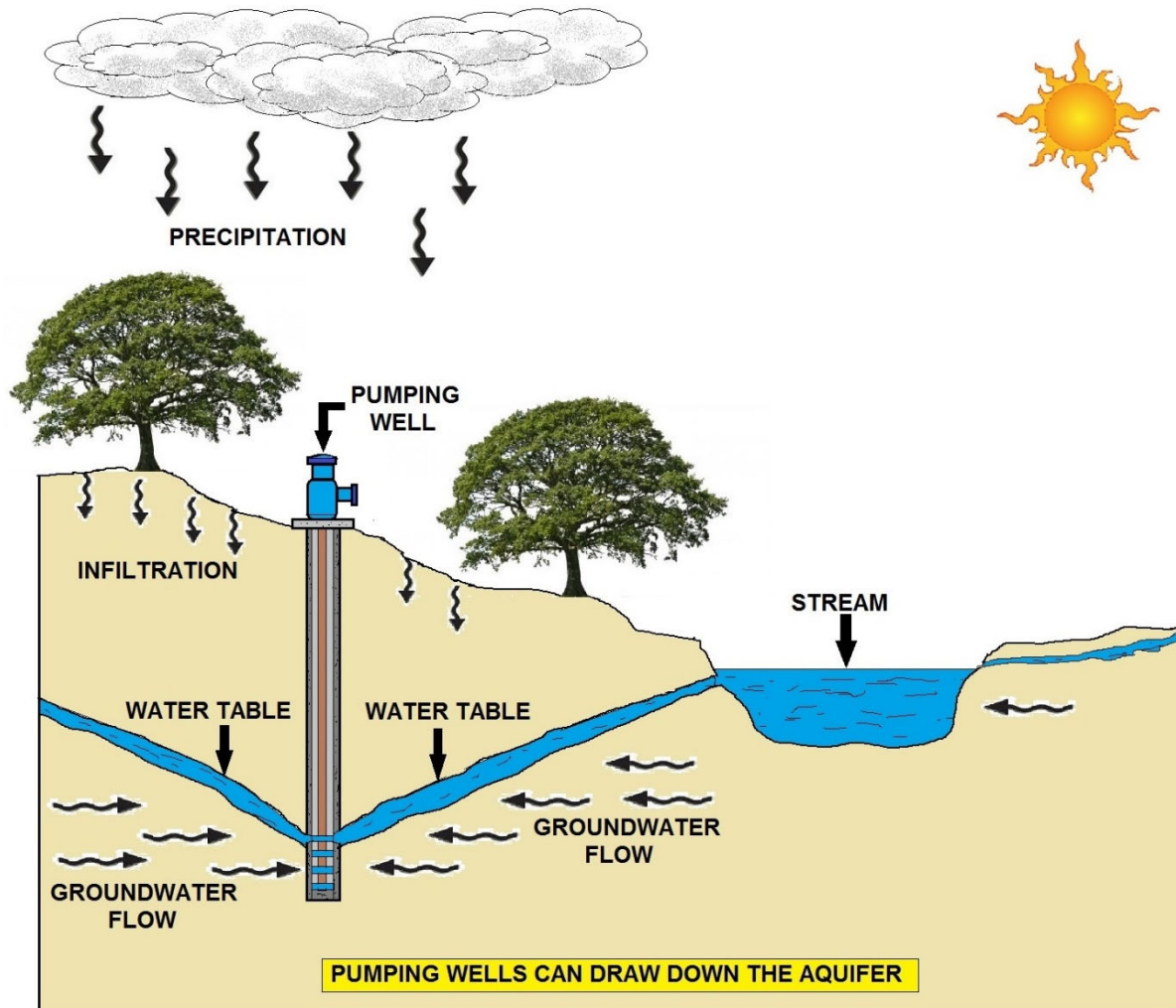

Groundwater represents the largest volume of fresh water on earth. Only three percent of the earth's fresh water resides in streams, lakes, and other surface water bodies. The other 97 percent is beneath the surface, flowing toward points of discharge such as streams, lakes, springs, and wetlands. Groundwater becomes surface water at these discharge points. Effective waste treatment is essential to protecting our water supplies.

Approximately 25 percent of households in North America utilize groundwater for consumption and other domestic uses. These same homes employ septic systems as their means for wastewater treatment (US EPA, 2008).

As water percolates through the soil, it is purified and in most cases requires no further treatment before being consumed. However, when the soil is overloaded with a treatable contaminant, or when the contaminant cannot be treated by the soil, the quality of the underlying groundwater may change significantly.

When a septic system fails to effectively treat and disperse effluent, it can become a source of pollution. This type of failure can occur in three different ways. The first way is when effluent ponds on the soil surface, causing a wet seepy area. The second obvious way that septic system can fail is to have effluent backing up into the dwelling. It is also important to prevent a third, and less obvious, type of failure, which is contamination of the ground or surface waters.

Pollution of groundwater (with nitrogen, pathogens, bacteria, chemicals, etc.) is very difficult to clean up, since the only access to the water table is through wells, trenches (if the water table is high enough), or natural discharge points such as springs. An incident of groundwater pollution often becomes a problem that persists for many years.

### **Soil Treatment Processes**

The soil treatment and dispersal zone provides for the final treatment and dispersal of septic tank effluent. To varying degrees, the soil treatment and dispersal zone treats the wastewater by acting as a filter, exchanger, or absorber by providing a surface area on which many chemical and biochemical processes occur. The combination of these processes, acting on the effluent as it passes through the soil, and purifies the water.

### **Biomat**

As septic tank effluent flows into a soil treatment trench, it moves vertically through the distribution media to the biomat where treatment begins. The biomat is a biological layer formed by anaerobic bacteria, which secrete a sticky substance and anchor themselves to the soil, rock particles, or other available surfaces.

The biomat develops first along the trench bottom, where effluent begins to pond. The biomat develops along the soil-media contact surfaces on the trench's sidewalls. When fully developed, the gray-to-black sticky biomat layer is about one inch thick.

Flow through a biomat is considerably slower than flow through natural soil, allowing unsaturated conditions to exist in the soil beneath the soil treatment trench. Unsaturated flow increases the travel time of effluent through the soil, ensuring that it has sufficient time to contact the surfaces of soil particles and microorganisms.

A properly functioning gravity-fed system will have wastewater ponded in the distribution media while the soil a few inches outside of and below the distribution media will be unsaturated. Unsaturated soil has pores containing both air and water so aerobic microorganisms living in the soil can effectively treat the wastewater as it travels through the soil system.

In unsaturated soil under a biomat, water movement is restricted. In order for the wastewater to move through the soil, it must be pulled or wicked through the fine pores by capillary action.

## **Sewage Treatment Utilizing Soil**

A developed biomat reaches equilibrium over time, remaining at about the same thickness and the same permeability if effluent quality is maintained. For this equilibrium to be maintained, the biomat and the effluent ponded within the trench must be in anaerobic conditions, the organic materials in the wastewater feed the anaerobic microorganisms, which grow and multiply, increasing the thickness and decreasing the permeability of the biomat.

On the soil side of the biomat beneath the drainfield, oxygen is present so that conditions are allowing aerobic soil bacteria to feed on and continuously break down the biomat. These two processes occur at about the same rate so that the thickness and permeability of the biomat remain in equilibrium.

If the quality of the effluent leaving the septic tank decreases because of failure to regularly pump out the septic tank, more food will be present for the anaerobic bacteria, which will cause an increase in the thickness of the biomat and decrease its permeability (Siegrist, 1987). If seasonally saturated conditions occur in the soil outside the trench, aerobic conditions will no longer exist, which will prevent aerobic bacteria from breaking down the biomat. Under these conditions the biomat will thicken, reducing its permeability and the effectiveness of effluent entering the soil.

### **Site Evaluations**

Site evaluations are a key driver of treatment system design. The success of any soil-discharging wastewater treatment system depends on the appropriate match between wastewater flow/strength, the treatment system design, and the site that receives effluent from the system. Site-specific observations and characterization by a qualified, experienced professional is essential to understanding local site conditions and ensuring the proper operation of individual and clustered wastewater systems.

### **Ensure Compliance with Regulations**

Nearly every state and most local, county, and city governments have developed written requirements governing the type of sites that can be permitted for subsurface effluent discharges from individual and clustered wastewater systems.

Regulatory compliance parameters include maximum slope angles acceptable for system components, appropriate soil types and depth, minimum depth-to-groundwater (or bedrock) requirements, and mandatory setback distances between system components and property lines, structures, and water bodies, among others.

Site evaluators should be familiar with the regulatory requirements for soil-discharging individual and clustered systems and the procedures for accommodating variances to those requirements, in terms of both the legal process for issuing variances and the system adaptations needed to ensure the desired treatment performance.

In most states, individual system regulations are promulgated by the public health agency. Requirements for clustered systems (e.g., those discharging more than 1,000 gallons per day) are sometimes under the purview of the state water resources agency. Large-capacity septic systems (i.e., those with the capacity to serve 20 or more people per day) are regulated by EPA and the states through the Underground Injection Control Program of the Safe Drinking Water Act.

### **Assure System Performance**

Wastewater systems depend on the soil for 1) final treatment of effluent from the tank or unit process components, and 2) dispersal of the effluent to the soil. As noted in the resource guide on system design, the desired final quality of the effluent depends on the constructed/installed treatment train and the pollutant removal capabilities of the soil.

The soil component of the system receives, stores, and treats incoming effluent. The subsurface “ponding” and slow release of effluent to the soil through the biomat facilitates treatment via chemical, physical, and biological processes such as aerobic nitrification of ammonia, adsorption of potential pollutants (e.g., phosphorus), filtration of solids, and decomposition of organic constituents. Predicting the pollutant removal and overall treatment efficacy of the soil component of the system requires a fairly comprehensive understanding of how these processes work, how they are enhanced or impeded, and how the upstream processes in the treatment train can be adjusted or adapted to ensure that the soil can handle the flow and pollutant load delivered.

### **Protect Public Health and Water Resources**

Individual and clustered wastewater systems can malfunction due to soil or site-related causes. These malfunctions can threaten public health or water resources by

- ✓ Causing sewage backups in homes or basements.
- ✓ Ponding poorly treated sewage in yards or landscaped areas.
- ✓ Contaminating surface waters with nutrients or bacteria.
- ✓ Polluting groundwater wells with bacteria or nitrate

The site evaluation procedures summarized below are designed to identify site characteristics that might contribute to elevated health or environmental risks to ensure that they can be addressed in the selection, configuration, sizing, or operation of the treatment system.

The preliminary review is performed prior to any fieldwork. It is based on information available from the owner and local agencies and on general resource information. The objectives of the preliminary review are to identify potential effluent infiltration sites, identify potential treatment system design boundaries (e.g., groundwater table, property line, etc.), assess the ability of the soil to provide final treatment, and develop a conceptual plan for supplying the level of treatment required prior to soil discharge. Preliminary screening of sites is an important aspect of the site evaluator’s role.

More than one receiving environment might be feasible and available for use. In addition, the desktop review might suggest that treatment be provided via clustered, rather than individual, facilities.

Focusing the effort on the most promising receiving environment and the most efficient and effective treatment works allows the evaluator to reasonably and methodically eliminate the least suitable sites early in the site evaluation process. For example, basic knowledge of the local climate might eliminate evaporation or evapotranspiration as a potential receiving environment immediately.

Also, the applicable local codes often prohibit direct or indirect discharges to surface waters (i.e., requiring an NPDES permit) from small systems. Knowledge of local conditions and regulations is essential during the screening process.

Resource materials and information to be reviewed may include, but are not limited to, the following:

**Property information** should include owner contact information, site legal description or address, plat map or boundary survey, description of existing site improvements (e.g., existing onsite wastewater systems, underground tanks, utility lines), previous and proposed uses, surrounding land use and zoning, and other available and relevant data.

**Detailed soil surveys** are available online from the Natural Resources Conservation Service (NRCS). Detailed soil surveys provide soil profile descriptions, identify soil limitations, estimate saturated soil conductivities and permeability values, describe typical landscape position and soil formation factors, and provide various other soil-related information. Soil survey data should be supplemented with detailed soil sampling at the site. The NRCS publication *Field Book for Describing and Sampling Soils* is an excellent manual for use in site evaluation.

**Quadrangle maps** provide general topographic information about a site and surrounding landscape. These maps are developed and maintained by the U.S. Geological Survey (USGS) and provide nationwide coverage typically at a scale of 1 inch = 2000 feet, with either a 10- or 20-foot contour interval.

At this scale, the maps provide information related to land use, public improvements (e.g., roadways), USGS benchmarks, landscape position and slope, vegetated areas, wetlands, surface drainage patterns, and watersheds. Aerial photographs are available from several popular online mapping sites (e.g., Google, Yahoo, MapQuest, etc.), many of which are free. Resolution varies across the nation. Some rural areas do not have fine resolution coverage. If available, aerial photographs can provide information regarding past and existing land use, drainage and vegetation patterns, surface water resources, and approximate location of property boundaries. Aerial photographs may be available from a variety of other sources, such as county or regional planning offices, property valuation, and agricultural agencies.

**Geology and basin maps** are especially useful for providing general information regarding bedrock formations and depths, groundwater aquifers and depths, flow direction and velocities, ambient water quality, surface water quality, stream flow, and seasonal fluctuations. If available, these maps can be obtained from USGS.

**Water resource and health agency information**, such as permit and other files for nearby treatment systems, can provide valuable information regarding local system designs, applications, and performance. Interviews with agency permitting, planning, and field staff can often provide valuable information on regional, local, and even site-specific conditions, such as water quality data, septic system complaints, and future plans for provision of clustered or centralized treatment services.

**Local installers and service providers** can provide information on other sites in the vicinity, existing technology performance, and general knowledge of soils and other factors that inform both the site evaluation and the selection of appropriate treatment system components. Climate data, such as temperature, precipitation, and pan evaporation rates can be obtained from the National Oceanic and Atmospheric Administration. This information is necessary if evapotranspiration systems are being considered. The evaluator must realize, however, that the data from the nearest weather station might not accurately represent the climate at the site being evaluated.

After the visual assessment of surface conditions are assessed, the site evaluation proceeds to an investigation of subsurface conditions, especially soil conditions and groundwater characteristics.

**Soils** are one of the most important factors to consider during the field investigation, because soil-discharging systems depend on the soil matrix for a significant portion of effluent treatment. Soil properties will affect the type of treatment system selected, the design loading rate, and the size of the dispersal field. Groundwater proximity and movement is also important in considering effluent residence time in unsaturated soil and the movement of pollutants that enter the water table.

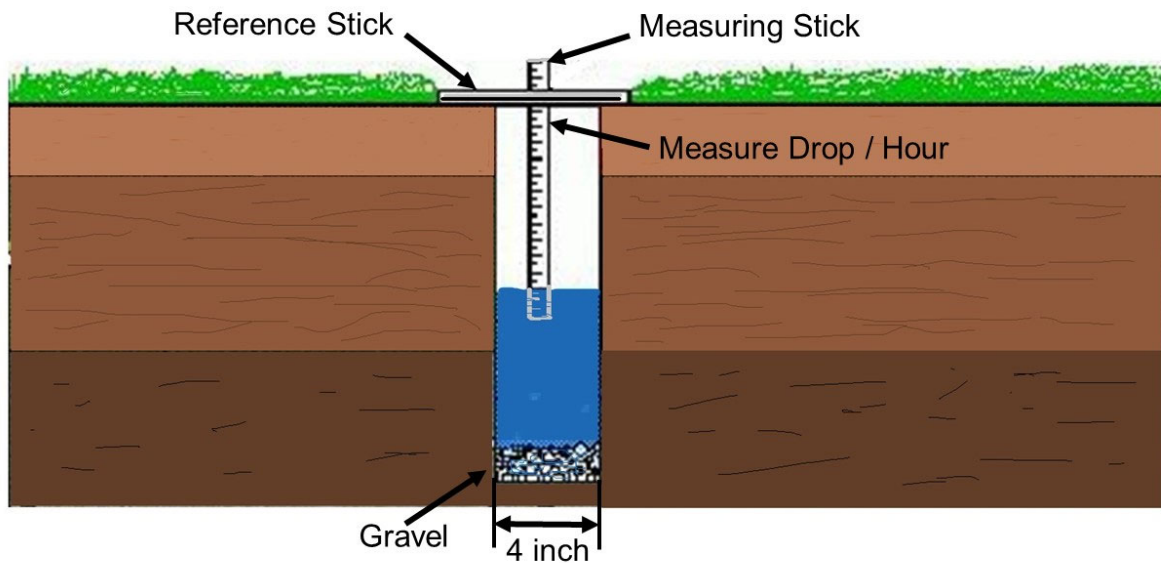

## MEASUREMENT OF PERCOLATION RATE

## Improving OSSF Treatment through Performance Requirements

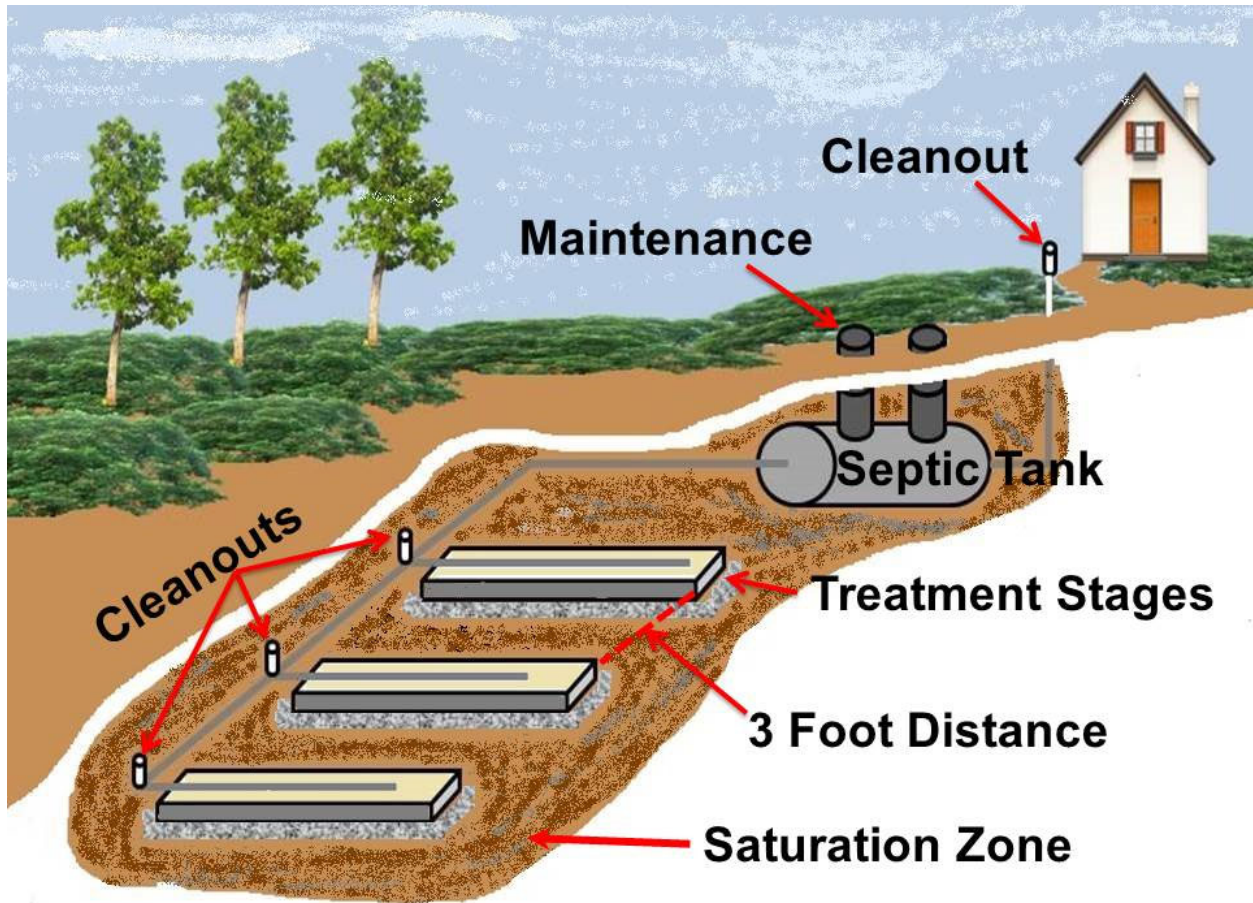

### Conventional Onsite Techniques

Conventional onsite wastewater treatment methods can be adapted to small community-wide systems by increasing their size. Conventional onsite systems are those where wastewater exits the home or business and passes through a septic tank before it is treated in a soil absorption field. These absorption fields can be pipe-in-rock trenches, chambers, or beds, although beds are not recommended for large flows. A small community that has onsite systems should give serious thought about whether their systems are failing and why. (Sanitary Surveys will be discussed in a later chapter.) Homes on very small lots in soils that are not very permeable may not be able to use onsite systems under any circumstances.

However, it may be possible to use existing or repaired onsite systems with good management and careful use. It may be less expensive in both the near and long terms to make such modifications as low flow showerheads and faucets and even replacing toilets with low flow models and washing machines with front loading models that use less water, than to build a sewer system and treatment plant. It may also require lifestyle changes such as spreading out laundry washing over several days, giving up garbage disposals, turning off the shower while soaping, and regular septic tank pumping. However, community-wide cooperation in water conservation might be the only solution needed. Another possible onsite alternative is the use of individual alternative systems such as aeration systems or sand filters.

They are more expensive than conventional onsite systems, but may be less expensive than central systems. There will be later discussions of ways to manage these systems as a group to get the best performance and control costs.

### **Shared Facilities**

It is possible that a small community is close enough to the existing wastewater treatment facility of another town that it is less expensive to convey wastewater to that treatment plant than to build a new one. If the existing plant is near capacity, they may not be able to accept additional wastewater. However, if an expansion is possible, the town may be willing to accept the small community's wastewater, if the community is willing to pay all or part of the expansion costs.

### **Lagoons (Wastewater Stabilization Ponds) Introduction**

Lagoons, also known as wastewater stabilization ponds, are open ponds where wastewater is treated by bacteria using oxygen in air provided by wind motion, algae, and for community-sized lagoons, usually mechanical aeration equipment. Alternative (Enhanced) Treatment Methods Alternative treatment systems such as sand filters and aeration systems provide treatment for the removal of organic material and some pathogens from the wastewater before discharge or absorption. These units can be adapted and scaled to handle the full size range from single-home onsite systems through municipal plants. We will cover this area in greater detail.

### **Flow Rates/Plant Sizing**

Among the factors to be considered in selecting a method of treatment, are the flow rate (average and minimum/maximum) and the strength (chemical composition/concentration) of the wastewater. There are typical assumptions used in engineering calculations. However, small communities may have special situations, such as the type of collection system that will require making sure these assumptions are correct for that community.

If a community has businesses or industries that are large water users, or if it has an unusually high number of businesses or industries for its size, detailed flow calculations should be made to account for them. If the collection system has a conventional gravity sewer, a factor for infiltration and inflow (I & I) must be added in. Infiltration is water that enters the collection system through loose pipe connections, broken pipes or manholes.

It is usually highest after rain or snow melt. If the water table is high, it may be a continuous problem. Inflow is water from sources such as foundation and roof drains, cooling water from air conditioners, and drainage from outdoor paved areas that have been connected into the sewer system.

Generally speaking, one requirement for new gravity sewer that is less than 24 inches in diameter is a maximum infiltration of 250 gallons per day (gpd) per mile of pipe for each inch of pipe diameter. (As an example, an 8 inch diameter pipe that is 2 miles long could have a maximum infiltration rate of 8 inches x 250 gpd x 2 miles = 4,000 gpd.) Older sewers can have much higher levels of infiltration. Inflow is possible with systems having septic tanks or grinder pumps, but it would probably be more noticeable in terms of overload or failure. A pressure sewer, in order to stay pressurized, must be constructed more tightly than a gravity sewer. Therefore, infiltration should be minimal. However, past experience with alternative collection systems indicate that I & I can still be an issue if the system is not constructed well. Sources of infiltration can include septic tanks and pump chambers that are not watertight, loose connections on the pipe between the house and the septic tank, and leaky manholes.



If assumptions about reduced wastewater flow because of the use of pressure sewers are to be valid, special attention during construction and maintenance must be paid to eliminating sources of infiltration.

### **Strength of Wastewater**

The strength of wastewater varies from home to home and with time of day. This is a challenge for onsite systems that is dealt with by making conservative assumptions for typical wastewater to be used in design. In a community situation, the wastewater streams combine and the differences level out. However, the type of collection system influences the strength. As was described above, a conventional gravity sewer will have an I & I component. A pressure sewer will have to be tighter so the infiltration will be less.

A substantial portion of the organic load is removed by a septic tank, so the strength of wastewater in a STEP (Septic Tank Effluent Pump) system would be lower than total household wastewater. On the other hand, the effluent from a grinder pump system will contain all material from household's wastewater. Because it will have lower I & I, it will be stronger than the wastewater from a gravity sewer. The design of a plant will need to be checked to be sure that it can handle the organic load as well as the hydraulic load.

### **Septic Tank Abandonment**

If a decision is made to replace or abandon septic tanks, the existing tanks must be cleaned and properly abandoned, usually by breaking the bottom, and possibly the sides, and filling with compacted soil or other inert material. Other inadequate or illegal systems such as cesspools and "ratholes" must also be abandoned. In some circumstances, additional measures may be required. The costs of this procedure must be included in the project costs.

Most onsite wastewater treatment systems are of the conventional type, consisting of a septic tank and a subsurface wastewater infiltration system (SWIS). Site limitations and more stringent performance requirements have led to significant improvements in the design of wastewater treatment systems and how they are managed.

Over the past 20 years, the onsite wastewater treatment system (OWTS) industry has developed many new treatment technologies that can achieve high performance levels on sites with size, soil, ground water, and landscape limitations that might preclude installing conventional systems.

New technologies and improvements to existing technologies are based on defining the performance requirements of the system, characterizing wastewater flow and pollutant loads, evaluating site conditions, defining performance and design boundaries, and selecting a system design that addresses these factors.

Performance requirements can be expressed as numeric criteria (e.g., pollutant concentration or mass loading limits) or narrative criteria (e.g., no odors or visible sheen) and are based on the assimilative capacity of regional ground water or surface waters, water quality objectives, and public health goals.

Wastewater flow and pollutant content help define system design and size and can be estimated by comparing the size and type of facility with measured effluent outputs from similar, existing facilities.

Site evaluations integrate detailed analyses of regional hydrology, geology, and water resources with site specific characterization of soils, slopes, structures, property lines, and other site features to further define system design requirements and determine the physical placement of system components.

Most of the alternative treatment technologies applied today treat wastes after they exit the septic tank; the tank retains settleable solids, grease, and oils and provides an environment for partial digestion of settled organic wastes.

Post-tank treatment can include aerobic (with oxygen) or anaerobic (with no or low oxygen) biological treatment in suspended or fixed-film reactors, physical/chemical treatment, soil infiltration, fixed-media filtration, and/or disinfection. The application and sizing of treatment units based on these technologies are defined by performance requirements, wastewater characteristics, and site conditions.

### **Creating a Management Structure**

The physical maintenance of decentralized onsite systems is not as difficult to establish as are the legal and financial arrangements needed to ensure that maintenance is accomplished and that homeowners pay their fair share of the costs in doing so. The policies and procedures that must be put in place with cluster systems can be more complex than with municipal sewer systems.

The establishment of a management entity for decentralized projects is necessary in order to apply for federal, state, or other funding, minimize liability, establish service boundaries, and to manage the administrative, financial, and operational activities for the services provided.

Acceptable management entities include counties, incorporated cities and towns, special governmental units (countywide or area-wide regional sewer districts, conservancy districts, etc.), public or private utilities, private corporations, and nonprofit organizations.

Each management entity has certain advantages and disadvantages and comes with its own set of guidelines for formation and oversight by regulatory authorities. Community leaders that are evaluating the use of decentralized cluster systems must decide which management entity would be most beneficial for their project.

## Performance-Based Standards

Most state and local system design codes traditionally have been based on prescriptive approaches that specify minimum site requirements, construction methods, and acceptable tank types and other components. However, the move toward site-appropriate, risk-based system design and the growing interest in clustered facilities has increased the need for performance-based design guidance.

Performance-based management approaches have been proposed as a substitute for prescriptive requirements for system design, siting, and operation. Performance codes set measurable outcomes that all treatment systems must achieve regardless of the technology used. British Columbia, Canada has a fairly comprehensive performance code, and Arizona has a hybridized code that allows a wide array of enhanced treatment methods for protecting groundwater.

### System Design Considerations

One of the more common reasons why some individual or cluster systems do not perform properly is inappropriate system/technology selection. A wastewater system should be matched to the volume and pollutant profile of wastewater, and the site, soil, and groundwater/surface water conditions must be known in detail in order to develop an appropriate system design.

State and local wastewater system permitting programs are expanding the options available for providing treatment services, especially for sites with limiting soil conditions and those with threatened or impaired water resources nearby. Instituting a protocol to provide guidance and oversight during the system design process can also help to address:

- ✓ Impacts of different pretreatment levels on the long-term hydraulic and pollutant removal performance of the soil.
- ✓ Cumulative impacts of high-density system installations.
- ✓ Operation and maintenance requirements of different treatment and soil dispersal technologies.
- ✓ Potential implications of water conservation fixtures.

The protocol should include a pre-design meeting between the permitting agency, the management entity, the designer, and the owner of the property. All of these parties have a stake in the performance of the system, and such a meeting can assist in identifying potential problems and solutions. The protocol should be as complete as possible and should feature a rational, defensible evaluation procedure for proposed designs and materials specifications. The protocol should be dynamic and should be regularly reviewed and updated as new information and experience is gained.

### Management Considerations

All wastewater treatment systems require management. Management services can be provided by an outside contractor or responsible management entity. In general, individual gravity flow systems with septic tanks and subsurface drainfields require less management attention; clustered facilities with collection system pumps, mechanized treatment units, and time or demand-dosed infiltration areas require much more.

## Factors that influence system management include:

- ✓ Operation in extreme conditions, such as very cold or wet climates.
- ✓ Life of system components and access to repair parts.
- ✓ Power reliability and backup power needs.
- ✓ Maintenance needs, including frequency and complexity of service.
- ✓ Availability of trained, reliable service providers.
- ✓ System compatibility with the owner's needs or lifestyle.
- ✓ Aesthetics (visible system components, noise, odors, etc.).
- ✓ Annual costs for operation, maintenance, and repair.

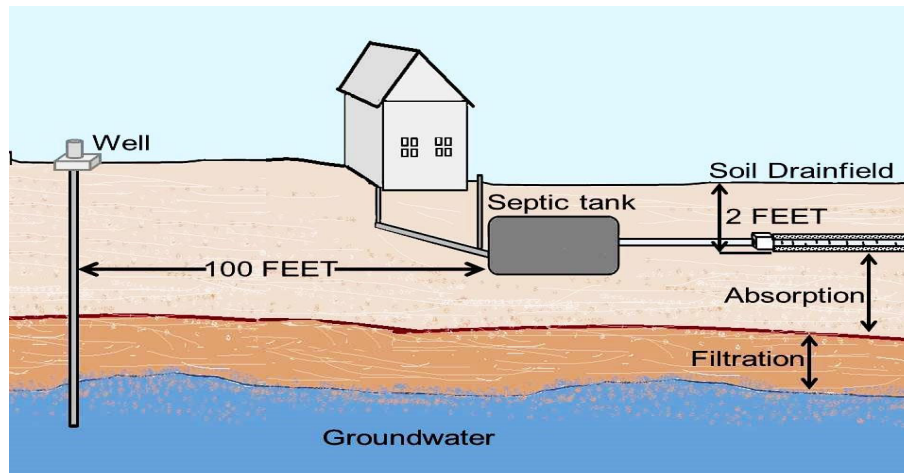

## Permitting and Approval Process

State and local governments vary considerably in their approach to approving system types and components and issuing installation and operation permits. Consultation with state and local regulatory agencies is required in all cases to ensure that minimum requirements are met. In general, a typical permit application procedure should include the following information:

- ✓ Consultation with the property owner regarding final design components.
- ✓ Detailed drawing for the site, including property lines, structures, easements, topographical and drainage features, vegetation, etc.
- ✓ Detailed drawings of all system components.
- ✓ Site preparation requirements.
- ✓ Documentation of decisions made regarding system location and features.
- ✓ Total dynamic head pressure requirements, if applicable.
- ✓ Specifications for equipment and materials, based on calculations.

It is important that the application include system drawings, narratives, forms, calculations, catalog cuts, photos, and other data, including detailed equipment and installation specifications to make siting the system components easier. If the site has been developed, all structures, utilities, and ingress and egress pathways should be identified. The source of potable water and distribution lines should be identified as well. If there is an existing wastewater treatment system, the condition of all components, including the reserve area, should be recorded and minimum setbacks met.

## Alternate Disinfectants

### Chloramine

Chloramine is a very weak disinfectant for Giardia and virus reduction; it is recommended that it be used in conjunction with a stronger disinfectant. It is best utilized as a stable distribution system disinfectant.

In the production of chloramines, the ammonia residuals in the finished water, when fed in excess of stoichiometric amount needed, should be limited to inhibit growth of nitrifying bacteria.

### Chlorine Dioxide

Chlorine dioxide may be used for taste and odor control, or as a pre-disinfectant. Total residual oxidants (including chlorine dioxide and chlorite, but excluding chlorate) shall not exceed 0.30 mg/L during normal operation or 0.50 mg/L (including chlorine dioxide, chlorite and chlorate) during periods of extreme variations in the raw water supply.

Chlorine dioxide provides good Giardia and virus protection but its use is limited by the restriction on the maximum residual of 0.5 mg/L  $\text{ClO}_2$ /chlorite/chlorate allowed in finished water. This limits usable residuals of chlorine dioxide at the end of a process unit to less than 0.5 mg/L.

Where chlorine dioxide is approved for use as an oxidant, the preferred method of generation is to entrain chlorine gas into a packed reaction chamber with a 25% aqueous solution of sodium chlorite ( $\text{NaClO}_2$ ).

**Warning:** Dry sodium chlorite is explosive and can cause fires in feed equipment if leaking solutions or spills are allowed to dry out.

### Ozone

Ozone is a very effective disinfectant for both Giardia and viruses. Ozone CT (Contact Time) values must be determined for the ozone basin alone; an accurate T10 value must be obtained for the contact chamber, residual levels measured through the chamber and an average ozone residual calculated.

Ozone does not provide a system residual and should be used as a primary disinfectant only in conjunction with free and/or combined chlorine.

Ozone does not produce chlorinated byproducts (such as trihalomethanes) but it may cause an increase in such byproduct formation if it is fed ahead of free chlorine; ozone may also produce its own oxygenated byproducts such as aldehydes, ketones, or carboxylic acids.

Any installed ozonation system must include adequate ozone leak detection alarm systems, and an ozone off-gas destruction system.

Ozone may also be used as an oxidant for removal of taste and odor, or may be applied as a pre-disinfectant.

### Ozone ( $\text{O}_3$ ) Molecule

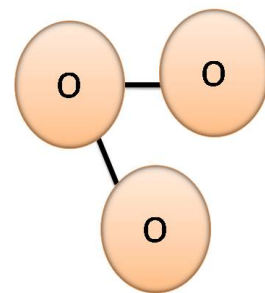

## Ozone

Ozone (O<sub>3</sub>) is probably the strongest oxidizing agent available for water treatment. Although it is widely used throughout the world, it has not found much application in the United States. Ozone is obtained by passing a flow of air or oxygen between two electrodes that are subjected to an alternating current in the order of 10,000 to 20,000 volts.



Liquid ozone is very unstable and can readily explode. As a result, it is not shipped and must be manufactured on-site. Ozone is a light blue gas at room temperature.

It has a self-polishing pungent odor similar to that sometimes noticed during and after heavy electrical storms. In use, ozone breaks down into oxygen and nascent oxygen.

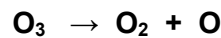

It is the nascent oxygen that produces the high oxidation and disinfections, and even sterilization. Each water has its own ozone demand, in the order of 0.5 ppm to 5.0 ppm. Contact time, temperature, and pH of the water are factors to be determined.

Ozone acts as a complete disinfectant. It is an excellent aid to the flocculation and coagulation process, and will remove practically all color, taste, odor, iron, and manganese. It does not form chloramines or THMs, and while it may destroy some THMs, it may produce others when followed by chlorination. Ozone is not practical for complete removal of chlorine or chloramines, or of THM and other inorganics. Further, because of the possibility of formation of other carcinogens (such as aldehydes or phthalates) it falls into the same category as other disinfectants in that it can produce DBPs.



Large Ozone generator

## Ultraviolet Radiation

The enormous temperatures on the sun create ultraviolet (UV) rays in great amounts, and this radiation is so powerful that all life on earth would be destroyed if these rays were not scattered by the atmosphere and filtered out by the layers of ozone gas that float some 20 miles above the earth.

This radiation can be artificially produced by sending strong electric currents through various substances. A sun lamp, for example, sends out UV rays that, when properly controlled, result in a suntan. Of course, too much UV will cause sunburn.

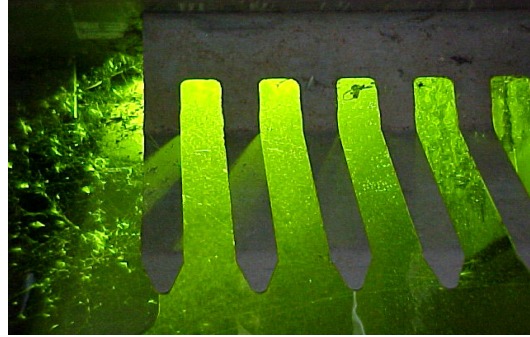

### Open Channel UV Lamp

The UV lamp that can be used for the disinfection of water depends upon the low-pressure mercury vapor lamp to produce the ultraviolet energy. A mercury vapor lamp is one in which an electric arc is passed through an inert gas. This in turn will vaporize the mercury contained in the lamp; and it is a result of this vaporization that UV rays are produced.



Enclosed UV lamp assembly. Assemblies will often need frequent cleaning and bulb replacements, there are facilities with 1,000's of bulbs.

The lamp itself does not come into with contact water, the lamp is placed inside a quartz tube, and the water is in contact with the outside of the quartz tube. Quartz is used in this case since practically none of the UV rays are absorbed by the quartz, allowing all of the rays to reach the water. Ordinary glass cannot be used since it will absorb the UV rays, leaving little for disinfection.

The water flows around the quartz tube. The UV sterilizer will consist of a various number of lamps and tubes, depending upon the quantity of water to be treated. As water enters the sterilizer, it is given a tangential flow pattern so that the water spins over and around the quartz sleeves. In this way the microorganisms spend maximum time and contact with the outside of the quartz tube and the source of the UV rays.

The basic design flow of water of certain UV units is in the order of 2.0 gpm for each inch of the lamp. Further, the units are designed so that the contact or retention time of the water in the unit is not less than 15 seconds. Most manufacturers claim that the UV lamps have a life of about 7,500 hours, which is about 1 years' time. The lamp must be replaced when it loses about 40% to 50% of its UV output; in any installation this is determined by means of a photoelectric cell and a meter that shows the output of the lamp. Each lamp is outfitted with its own photoelectric cell, and with its own alarm that will be activated when the penetration drops to a present level.

Ultraviolet radiation is an excellent disinfectant that is highly effective against viruses, molds, and yeasts; and it is safe to use. It adds no chemicals to the water, it leaves no residual, and it does not form THMs. It is used to remove traces of ozone and chloramines from the finished water. Alone, UV radiation will not remove precursors, but in combination with ozone, it is said to be effective in the removal of THM precursors and THMs.

The germicidal effect of UV is thought to be associated with its absorption by various organic components essential to the cell's functioning. For effective use of ultraviolet, the water to be disinfected must be clean, and free of any suspended solids. The water must also be colorless and must be free of any colloids, iron, manganese, taste, and odor.

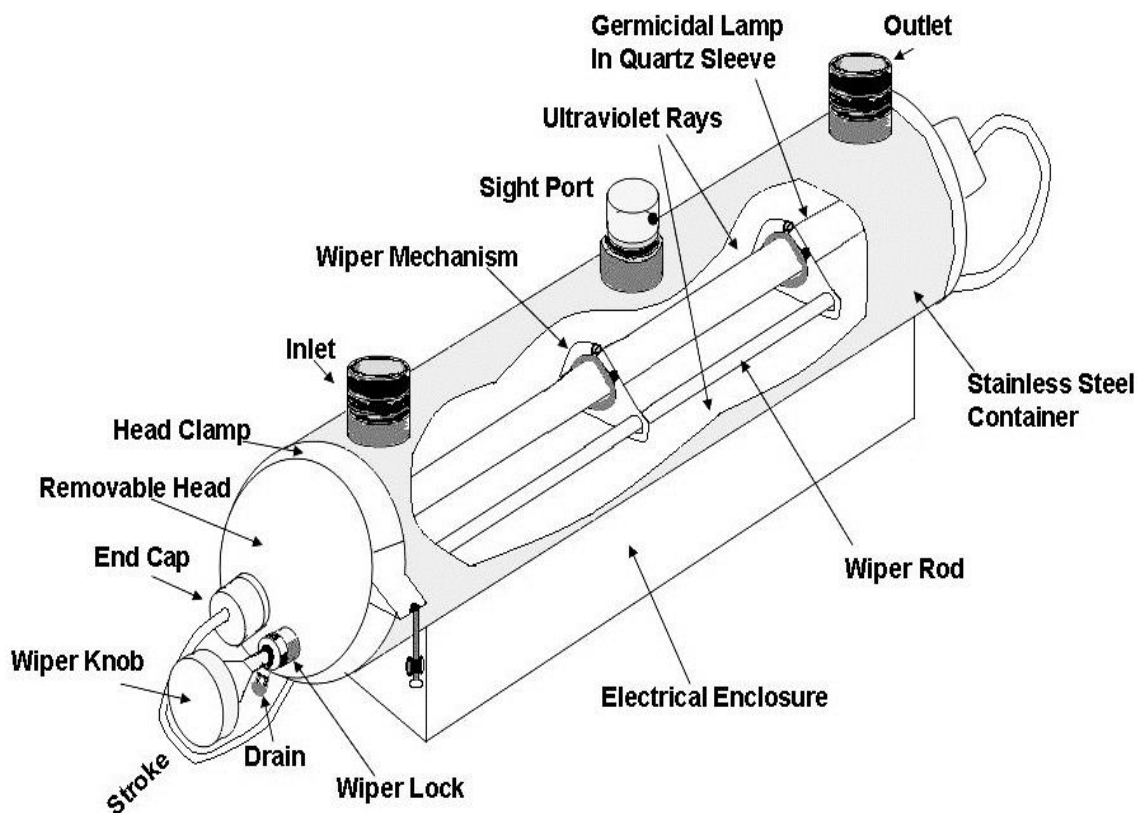



These are conditions that must be met. Also, although a water may appear to be clear, such substances as excesses of chlorides, bicarbonates, and sulfates affect absorption of the ultraviolet ray.

These parameters will probably require at least filtration of one type or another. The UV manufacturer will of course stipulate which pretreatment may be necessary.

<b>Removal of Disinfection By-products</b>		
<b><i>Disinfectant</i></b>	<b><i>Disinfectant By-product</i></b>	<b><i>Disinfectant By-product Removal</i></b>
Chlorine (HOCl)	Trihalomethane (THM)  Chloramines Chloroprene	Granular Activated Carbon (GAC), resins, controlled coagulation, aeration. GAC-UV GAC
Chloramines (Ch <sub>2</sub> Cl <sub>y</sub> )	Probably no THM Others?	GAC  UV?
Chlorine dioxide (ClO <sub>2</sub> )	Chlorites Chlorates	Use of Fe <sup>2+</sup> in coagulation, RO, ion-exchange
Permanganate (KMnO <sub>4</sub> )	No THMs	
Ozone (O <sub>3</sub> )	Aldehydes, Carboxylics, Phthalates	GAC
Ultraviolet (UV)	None known	GAC

The table indicates that most of the disinfectants will leave a by-product that is or would possibly be inimical to health. This may aid with a decision as to whether or not precursors should be removed before these disinfectants are added to water.

If it is decided that removal of precursors is needed, research to date indicates that this removal can be attained through the application of controlled chlorination plus coagulation and filtration, aeration, reverse osmosis, nanofiltration, GAC ( Granular Activated Charcoal) or combinations of others processes.

BACTERIA / VIRUS	DISINFECTION TIME FOR FECAL CONTAMINANTS IN CHLORINATED WATER
<b>E. COLI</b> (BACTERIUM)	LESS THAN 1 MINUTE OF CONTACT TIME
<b>HEPATITUS A</b> (VIRUS)	APPROXIMATELY 16 MINUTES CONTACT TIME
<b>GIARDIA</b> (PARASITE)	APPROXIMATELY 45 MINUTES CONTACT TIME
<b>CRYPTOSPORIDIUM</b> (PARASITE)	APPROXIMATELY 10.6 DAYS (15,300 minutes)

**CHLORINE TIMETABLE FOR PROPER DISINFECTION**

CHEMICAL NAME	CHEMICAL FORMULA	FORM	% CHLORINE	STORAGE	QUALITY	ADVANTAGE	DISADVANTAGE
CHLORINE GAS	$Cl_2$	GAS	100%	MAY STORE FOR LONG PERIODS	CONSISTENTLY HIGH QUALITY	COST EFFECTIVE	BY-PRODUCT FORMATIONS (THM'S, HAA)
SODIUM HYPOCHLORITE	$NaOCl$	LIQUID	~ 12%	LIMITED DUE TO DECOMPOSITION	POOR QUALITY DUE TO LIMITED CONTROL	LESS TRAINING REQUIRED TO HANDLE DUE TO FEWER REGULATIONS	LIMITED SHELF LIFE AND HIGHER COST

**CHLORINE GAS VS. SODIUM HYPOCHLORITE (BLEACH)**

## Summary

The lack of knowledge about alternative collection and treatment technologies has led to a high degree of design conservatism among engineering consultants, sanitarians, and environmental health specialists, the principal sources of professional advice available to local governments.

Training and education in design, installation and maintenance of onsite systems has been aimed at environmental sanitarians and installation contractors, not at the local planning and government officials and design engineering community who are primarily responsible for recommendations regarding public sewer installations. Until alternatives are evaluated, traditional, often prohibitively expensive, wastewater systems will continue to be recommended, and will continue to be too expensive to solve the problem.

Gas rises to top.

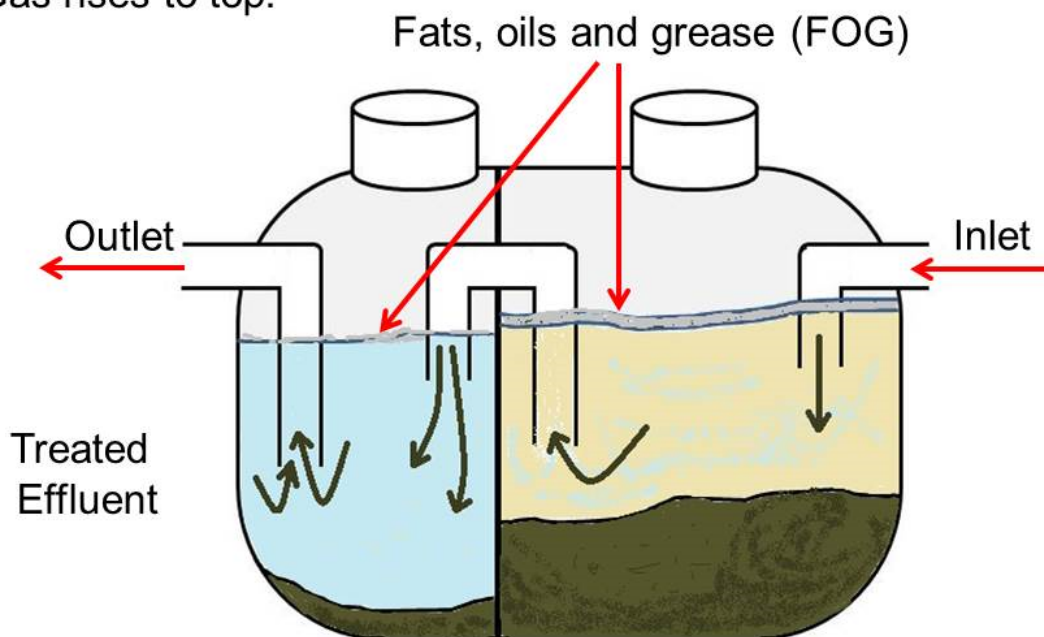

Solids settle to the bottom.

### Proper Maintenance

Proper maintenance can add years to an older system. Even well-designed and properly installed septic systems can fail earlier than expected if previous homeowners did not perform routine maintenance.

Try to determine how frequently the tank has been pumped from the realty agent or owner. Ask to see maintenance records. Keep in mind the necessary pumping frequency depends on the size of the household and the size of the tank. For example, a four-bedroom home with a 1,250 gallon tank should be pumped approximately every 2.6 years. Modern conveniences such as garbage disposals, hot tubs, or whirlpools will increase the necessary pumping frequency.

## **Normal Operation and Usage**

As the customer uses the septic system, sludge will accumulate in the tank. Properly designed tanks have enough space for up to three years of safe accumulation. Once the sludge has reached this level, the separation of solids and scum no longer takes place, and sewage may overflow into the absorption/ leach field.

A common misconception is that the key component of a septic system is the septic tank. The soil absorption system, or leach field, is where much of the treatment occurs.

After the septic tank has settled out solids, clarified wastewater is dispersed through perforated pipes into the soil. Soil is the key to clean water. It acts as a physical strainer, chemical renovator and biological recycler for the wastewater passing through it.

As wastewater goes through the leach field beneath and to the sides of the pipes, a black, jelly-like mat (or biomat) forms. This thin layer of anaerobic organisms helps regulate the flow of wastewater to the soil and preys on potentially pathogenic bacteria, viruses and parasites. It also converts nutrients into a form that can be used by plants.

The biomat also is a common trouble-spot for clogging, as it has low permeability. Failing to pump out your septic system or discharging too much wastewater down the drain can lead to a buildup of organic material, which causes the biomat to grow too thick. This sludge flow into the leach field can damage the operation of the septic system, and lead to costly repairs. This can be prevented by periodically pumping the accumulated sludge.

## **Permit**

Generally, a permit must be obtained before starting construction or repair work. However, certain residential properties may be exempt from state permitting requirements. When authority is based on a local ordinance, regulation can be more restrictive than the state standard; check with your local authority.

In most counties, the local health department issues OWTS construction permits. In the other counties the authority is another agency, such as a sewer district, building department, or planning and zoning department.

Several factors should be considered when choosing the type of onsite system for a site including: soil/site limitations, available space, operation and maintenance (O & M) requirements, initial costs as well as O & M costs, landscape disturbance, and the owners' preferences and ability to manage the system.

Of these considerations, often the most limiting is the soil resource or site and space limitations. When the soil and site are suited to a lagoon or to a septic tank and conventional soil absorption system, any registered OWTS installer can assist with the permitting and can install a basic onsite system.

When site limitations or other factors lead to an advanced OWTS, the installer must be registered as an advanced OWTS installer.

## References for Drip Dosing & Pressure Dosing Septic System Design Specifications

- Amoozegar, A.; E. W. West; K. C. Martin; and D. F. Weymann. Dec. 11–13, 1994. "Performance Evaluation of Pressurized Subsurface Wastewater Disposal Systems." On-Site Wastewater Treatment: Proceedings of the Seventh International Symposium on Individual and Small Community Sewage Systems. Atlanta, Georgia.
- Berkowitz, S. J. . PRESSURE MANIFOLD DESIGN FOR GROUND ABSORPTION SEWAGE SYSTEMS [PDF] (1986) Originally in In: On-Site Wastewater Treatment: Proceedings of the fourth national symposium on individual and small community sewage systems. Dec. 10-11, 1984. New Orleans. American Society of Agricultural Engineers.
- Cogger, C., B. L. Carlile, D. Osborne and E. Holland. 1982. Design and installation of low-pressure pipe waste treatment systems. UNC Sea Grant College Pub. UNC-SG-82-03. 31p.
- Hoover, M. T. and A. Amoozegar. Sept. 18–19, 1989. "Performance of Alternative and Conventional Septic Tank Systems." Proceedings of the Sixth Northwest On-Site Wastewater Treatment Short Course. University of Washington. Seattle, Washington. pp. 173–203.
- Hoover, M. T.; T. M. Disy; M. A. Pfeiffer; N. Dudley; and R. B. Mayer. 1995. On-Site System Operation and Maintenance Operators Manual. The National Environmental Training Center for Small Communities (NETCSC). West Virginia University. Morgantown, West Virginia.
- Lesikar, Bruce. Agricultural Communications, The Texas A&M University System. Low-pressure dosing. Publication L-5235. 6 Sept. 1999.
- "Low-Pressure Pipe [Septic Dosing] Systems" [PDF] National Small Flows Clearinghouse, Project funded by the U.S. Environmental Protection Agency under Assistance Agreement No. CX824652, retrieved 2017/04/21, original source: [http://www.nesc.wvu.edu/pdf/WW/publications/eti/LPP\\_gen.pdf](http://www.nesc.wvu.edu/pdf/WW/publications/eti/LPP_gen.pdf)
- Marinshaw [excerpted by EHS, NC Public Health], "RECOMMENDED DESIGN CONSIDERATIONS FOR PREVENTING COMMON LPP PROBLEMS" [PDF], excerpted by North Carolina Health & Human Services DHHS from OSWS/DEH/NCDEHNR - 2/95, rev. 3/96; addendum to "Design of Large Low-pressure Pipe Distribution Systems in North Carolina", Marinshaw, 1988
- Mitchell, D. 1983. Nonuniform distribution by septic tank systems. 1982 southeastern on-site sewage treatment conference. N. C. Div. Of Health Services, Raleigh, NC 37-45.
- Ohio - DRIP DISTRIBUTION SEPTIC SYSTEM DESIGN SPECIFICATIONS [PDF] retrieved 2017/10/20, original source: <http://www.odh.ohio.gov/>
- Ohio - LOW PRESSURE DISTRIBUTION SYSTEM SEPTIC DESIGN SPECIFICATIONS [PDF] retrieved 2017/10/20, original source: <http://www.odh.ohio.gov/>
- Ohio - LOW PRESSURE SAND FILTER SEPTIC DESIGN SPECIFICATIONS [PDF] retrieved 2017/10/20, original source: <http://www.odh.ohio.gov/>
- Otis, R. J. 1982. Pressure distribution design for septic tank systems. Jour. Of the Env. Eng. Div., ASCE 108(1): 123-140.
- Otis, R. J., J. C. Converse, B. L. Carlile and J. E. Witty. 1977. Effluent distribution. Home Sewage Treatment. ASAE Pub. 5-77. St. Joseph, Mich. 61-85
- "PRESSURE DISTRIBUTION SYSTEMS, Recommended Standards and Guidance for Performance, Application, Design, and Operation & Maintenance", [PDF] Washington State Department of Health, 243 Israel Road SE, Tumwater, WA 98501 USA, Tel: (360) 236-3330 , Email: [wastewatermanagement@doh.wa.gov](mailto:wastewatermanagement@doh.wa.gov) (2012), retrieved 2017/04/21,

original source: <http://www.doh.wa.gov/Portals/1/Documents/Pubs/337-009.pdf> DOH Publication #337-009

- Seigrist, Robert L., E. Jerry Tyler, Petter D. Jenssen, "DESIGN AND PERFORMANCE OF ONSITE WASTEWATER SOIL ABSORPTION SYSTEMS" [PDF] Extensive, detailed design guide, National Research Needs Conference Risk-Based Decision Making for Onsite Wastewater Treatment Washington University St. Louis, Missouri 19-20 May 2000, Sponsored by U.S. Environmental Protection Agency Electric Power Research Institute's Community Environmental Center National Decentralized Water Resources Capacity Development Project
- "Septic tank/Pretreatment to Low Pressure Pipe", [PDF] Ohio State Department of Health, retrieved 2017/04/21, original source: <https://www.odh.ohio.gov/~media/ODH/ASSETS/Files/eh/STS/ho-FSlpp.ashx> [does not contain design details]
- Uebler, R. L. 1982. "Design of Low-Pressure Pipe Wastewater Treatment Systems." 1982 Southeastern On-Site Sewage Treatment Conference Proceedings. North Carolina Division of Health Services and the Soil Science Department. North Carolina State University.
- U.S. Environmental Protection Agency (EPA) "DECENTRALIZED SYSTEMS TECHNOLOGY FACT SHEET LOW PRESSURE PIPE SYSTEMS" [PDF], EPA 832-F-99-076  
September 1999, retrieved 2017/04/21, original source: <https://www3.epa.gov/npdes/pubs/finallpp.pdf>
- U.S. Environmental Protection Agency (EPA) "Small Wastewater Systems: Alternative Systems for Small Communities and Rural Areas." EPA Office of Water. 830/F-92/001. May 1992.
- Curry, D. 1998. National Inventory of Key Activities Supporting the Implementation of Decentralized Wastewater Treatment. Fact Sheet No. 3-2. Research conducted by the U.S. Environmental Protection Agency, Office of Wastewater Management. Available from Tetra Tech, Inc., Fairfax, VA.
- Florida Department of Health and Rehabilitative Services (Florida DHRS). 1993. Onsite Sewage Disposal System Research in Florida: An Evaluation of Current OSDS Practices in Florida. Report prepared for the Florida Department of Health and Rehabilitative Services, Environmental Health Program, by Ayres Associates, Tallahassee, FL.
- Fogarty, S. 2000. Land Use and Zoning Laws. Small Flows Quarterly 1(1):13. Hoover, M.T., A.R. Rubin, and F. Humenik. 1998. Choices for Communities: Wastewater Management Options for Rural Areas. AG-585. North Carolina State University, College of Agriculture and Life Sciences, Raleigh, NC. Kreissl, J.F. 1982. Evaluation of State Codes and Their Implications.
- In Proceedings of the Fourth Northwest On-Site Wastewater Disposal Short Course, September, University of Washington, Seattle, WA. Kreissl, J.F. 2000. Onsite Wastewater Management at the Start of the New Millenium. Small Flows Quarterly 1(1):10-11. National Onsite Wastewater Recycling Associations (NOWRA). 1999.

## Post Quiz

### Soil Treatment Processes

1. The soil treatment and \_\_\_\_\_ provides for the final treatment and dispersal of septic tank effluent.

### Biomat

2. In unsaturated soil under a biomat, \_\_\_\_\_ is restricted.

### Sewage Treatment Utilizing Soil

3. A developed biomat reaches \_\_\_\_\_ over time, remaining at about the same thickness and the same permeability if effluent quality is maintained.

### Site Evaluations

4. Site evaluations are a key driver of treatment system design. The success of any soil-discharging wastewater treatment system depends on the appropriate match between \_\_\_\_\_, the treatment system design, and the site that receives effluent from the system.

### Assure System Performance

5. Wastewater systems depend on the soil for 1) final treatment of effluent from the tank or unit process components, and 2) \_\_\_\_\_.

### Improving OSSF Treatment through Performance Requirements

6. Most onsite wastewater treatment systems are of the conventional type, consisting of a septic tank and a \_\_\_\_\_.

### Performance-Based Standards

7. The move toward site-appropriate, risk-based system design and the growing interest in \_\_\_\_\_ has increased the need for performance-based design guidance.

8. \_\_\_\_\_ approaches have been proposed as a substitute for prescriptive requirements for system design, siting, and operation.

### System Design Considerations

9. One of the more common reasons why some individual or cluster systems do not perform properly is inappropriate \_\_\_\_\_ selection.

### **Management Considerations**

10. All \_\_\_\_\_ systems require management. Management services can be provided by an outside contractor or responsible management entity.

11. Factors that influence system management include: \_\_\_\_\_, such as very cold or wet climates.

12. Maintenance needs, including frequency and \_\_\_\_\_.

### **Permitting and Approval Process**

13. The source of potable water and distribution lines should be identified as well. If there is an existing wastewater treatment system, the condition of all components, including the reserve area, should be recorded and \_\_\_\_\_.

### **Summary**

#### **OSSF Maintenance**

14. \_\_\_\_\_ can add years to an older system. Even well-designed and properly installed septic systems can fail earlier than expected if previous homeowners did not perform routine maintenance.

15. Try to determine how frequently the tank has been pumped from the realty agent or owner. Ask to see maintenance records. Keep in mind the necessary pumping frequency depends on the size of the household and the size of the \_\_\_\_\_.

16. For example, a four-bedroom home with a 1,250 gallon tank should be pumped approximately every 2.6 years. Modern conveniences such as garbage disposals, hot tubs, or whirlpools will increase the necessary pumping frequency.

### **Answers**

1. Dispersal zone, 2. Water movement, 3. Equilibrium, 4. Wastewater flow/strength, 5. Dispersal of the effluent to the soil, 6. Subsurface wastewater infiltration system (SWIS), 7. Clustered facilities, 8. Performance-based management, 9. System/technology, 10. Wastewater treatment, 11. Operation in extreme conditions, 12. Complexity of service, 13. Minimum setbacks met, 14. Proper maintenance, 15. Tank, 16. 2.6



## Chapter 3- SUBSURFACE WASTEWATER INFILTRATION CONSTRUCTION SECTION

**Section Focus:** You will learn about the Clean Water Act and the basics of the decentralized or onsite wastewater facility and its operational requirements. At the end of this section, you the student will be able to describe the basics of the subsurface wastewater collection and infiltration system. There is a post quiz at the end of this section to review your comprehension and a final examination in the Assignment for your contact hours.

**Scope/Background:** Onsite sewage treatment system installers/operators install septic systems in compliance with all state and federal requirements and permits to ensure that untreated wastewater will not contaminate the environment or pollute waterways.

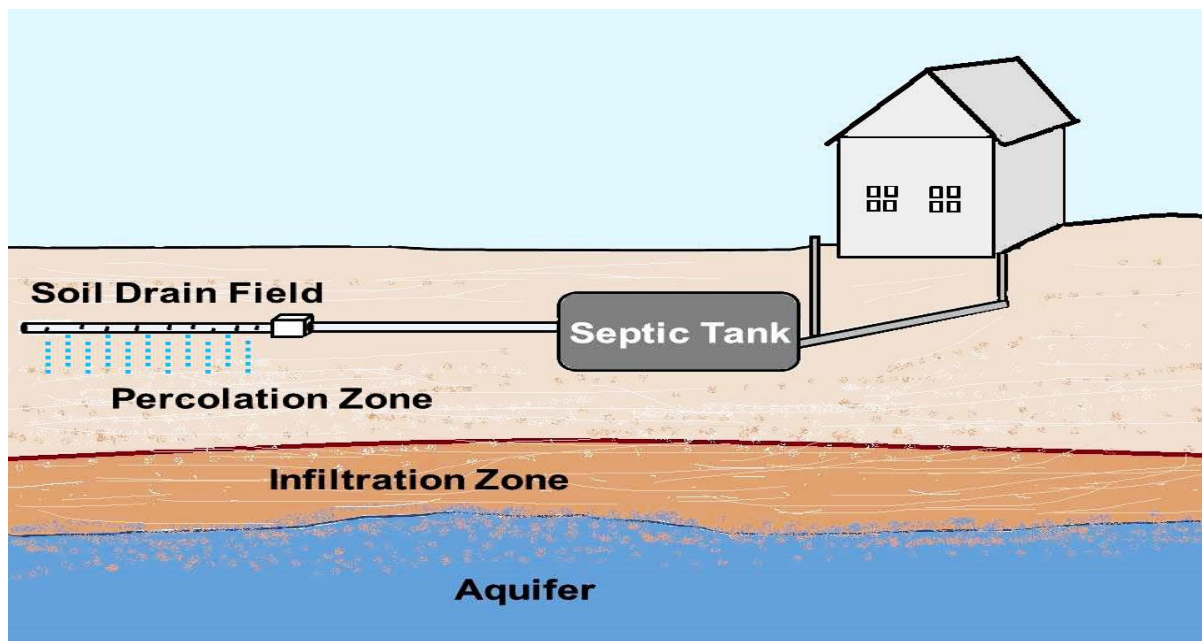

Appropriate wastewater treatment system construction and/or installation practices are critical to the performance of individual and clustered systems. Construction activities can affect short-term and long-term system performance by failing to adhere to material specifications, neglecting proper pipe slope requirements, inadvertently switching tank inlet/outlet orientation, or failing to protect infiltration area soils from equipment compaction.

Infiltration area protection, a key component of good system installation practice, should be carefully considered during site preparation, construction equipment selection and use, and before and during construction.

The development of a final design plan that includes drawings, narratives, forms, calculations, photos, and other data, including detailed equipment and installation specifications, will help ensure a successful outcome. This information must be assembled into a cohesive document to allow the proper installation of the design without the need for any assumptions.

Onsite wastewater treatment systems (OWTSs) have evolved from the pit privies used widely throughout history to installations capable of producing a disinfected effluent that is fit for human consumption. Although achieving such a level of effluent quality is seldom necessary, the ability of onsite systems to remove settleable solids, floatable grease and scum, nutrients, and pathogens from wastewater discharges defines their importance in protecting human health and environmental resources. In the modern era, the typical onsite system has consisted primarily of a septic tank and a soil absorption field, also known as a subsurface wastewater infiltration system, or SWIS. In this manual, such systems are referred to as conventional systems.

Septic tanks remove most settleable and floatable material and function as an anaerobic bioreactor that promotes partial digestion of retained organic matter. Septic tank effluent, which contains significant concentrations of pathogens and nutrients, has traditionally been discharged to soil, sand, or other media absorption fields (SWISs) for further treatment through biological processes, adsorption, filtration, and infiltration into underlying soils.

Conventional systems work well if they are installed in areas with appropriate soils and hydraulic capacities; designed to treat the incoming waste load to meet public health, ground water, and surface water performance standards; installed properly; and maintained to ensure long-term performance.

### **Background and Use of Onsite Wastewater Treatment Systems**

These criteria, however, are often not met. Only about one-third of the land area in the United States has soils suited for conventional subsurface soil absorption fields.

System densities in some areas exceed the capacity of even suitable soils to assimilate wastewater flows and retain and transform their contaminants. In addition, many systems are located too close to ground water or surface waters and others, particularly in rural areas with newly installed public water lines, are not designed to handle increasing wastewater flows.

Conventional onsite system installations might not be adequate for minimizing nitrate contamination of ground water, removing phosphorus compounds, and attenuating pathogenic organisms (e.g., bacteria, viruses).

Nitrates that leach into ground water used as a drinking water source can cause methemoglobinemia, or blue baby syndrome, and other health problems for pregnant women.

Nitrates and phosphorus discharged into surface waters directly or through subsurface flows can spur algal growth and lead to eutrophication and low dissolved oxygen in lakes, rivers, and coastal areas.

In addition, pathogens reaching ground water or surface waters can cause human disease through direct consumption, recreational contact, or ingestion of contaminated shellfish. Sewage might also affect public health as it backs up into residences or commercial establishments because of OWTS failure.

**Characteristics of Typical SWIS Applications Table**

<b>Characteristic</b>	<b>Typical application</b>	<b>Applications to avoid<sup>a</sup></b>
Type of wastewater	Domestic and commercial (residential, mobile home parks, campgrounds, schools, restaurants, etc.)	Facilities with non-sanitary and/or industrial wastewaters. Check local codes for other possible restrictions
Daily flow	<20 population equivalents unless a management entity exists	>20 population equivalents without a management program. Check local codes for specific or special conditions (e.g., USEPA or state Underground Injection Control Program Class V rule)
Minimum pretreatment	Septic tank, imhoff tank	Discharge of raw wastewater to SWIS
Lot orientation	Loading along contour(s) must not exceed the allowable contour loading rate	Any site where hydraulic loads from the system will exceed allowable contour loading rates
Landscape position	Ridge lines, hilltops, shoulder/side slopes	Depressions, foot slopes concave slopes, floodplains
Topography	Planar, mildly undulating slopes of ≤ 20% grade	Complex slopes of >30%
Soil texture	Sands to clay loams	Very fine sands, heavy clays, expandable clays
Soil structure	Granular, blocky	Platy, prismatic, or massive soils
Drainage	Moderately drained or well drained sites	Extremely well, somewhat poor, or very poorly drained sites
Depth to ground water or bedrock	>5 feet	<2 feet. Check local codes for specific requirements

<sup>a</sup> Avoid when possible.

Source: Adapted from WEF, 1990.

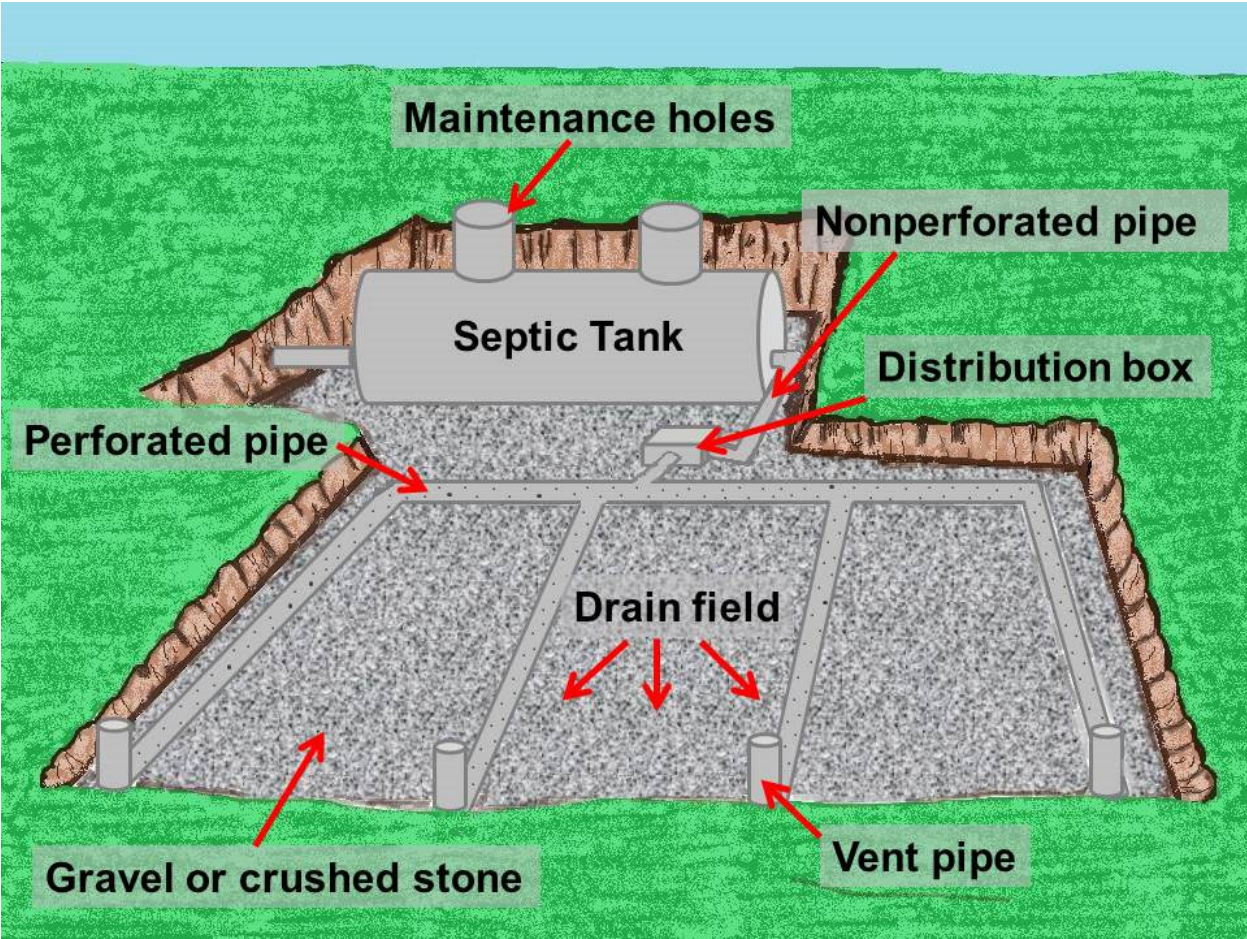

## Septic Site Preparation and Excavation Practices Sub-Section

Overhead power lines, steep slopes, and excavations at the installation site can all present serious safety hazards. A brief preconstruction meeting can ensure that safety hazards and practices to eliminate, minimize, or respond to them are identified.

Site preparation requires a number of activities including clearing and surface preparation for filling. Use of lightweight tracked equipment will minimize soil compaction. Soil moisture should be determined to ensure that it is dry, and care should be taken to avoid soil disturbance as much as possible. To avoid potential soil damage during construction, the soil below the proposed infiltration surface elevation must be below its plastic limit during construction (i.e., it must lack the moisture required to make it moldable into stable shapes). This should be tested before excavation begins.

Site excavation is conducted only when the infiltration surface can be covered the same day to avoid loss of soil permeability from wind-blown silt or raindrop impact. Another solution is to use lightweight gravel-less systems, which reduce the damage and speed the construction process. Site access points and areas for traffic lanes, material stockpiling, and equipment parking should be designated on the drawings for the contractor.

Heavy equipment should be diverted from the absorption field to avoid compaction and damage to the area. Flagging off the infiltration area as early as possible is critical to ensure long-term function of the system.

Clearing should be limited to mowing and raking with minimal disturbance to the surface. If trees are cut, they should be removed without heavy machinery, and, if necessary, stumps ground out. Grubbing of the site (mechanically raking away roots) should be avoided. If the site is to be filled, the surface should be moldboard- or chisel-plowed parallel to the contour (usually to a depth of seven to ten inches) when the soil is sufficiently dry to ensure maximum vertical permeability. The organic layer should not be removed.

Scarifying the surface with the teeth of a backhoe bucket is not sufficient. All efforts should be made to avoid any disturbance to the exposed infiltration surface.

### Field Construction Practices

Changes in construction practices over the past 25 years have led to improvements in the performance of individual wastewater systems. For example, construction materials used in plumbing, wastewater lines, and lateral fields should meet American Society for Testing and Materials standards. Avoid work during wet conditions.

Smearred soil surfaces in infiltration trenches should be scarified and the surface gently raked prior to installing the gravel or gravel-less piping/chambers. If gravel or crushed rock is to be used for the system medium, the rock should be placed in the trench by using the backhoe bucket to long-term system performance. If soil compaction occurs during drainfield installation, it might be possible to restore the area, but only by removing the compacted layer.

It might be necessary to remove as much as four inches of soil to regain the natural soil porosity and permeability (Tyler et al., 1985). Consequences of the removal of this amount of soil over the entire infiltration surface can be significant. It will reduce the separation distance to the restrictive horizon and could place the infiltration surface in an unacceptable soil horizon.

For gravel filled trenches, the trench bottom should be left rough and covered with six inches of clean (i.e., no fines) rock. Distribution pipes should be carefully placed over the rock, leveled, and bedded in on the sides.

After the rock and pipes have been placed in the trench, the filter fabric should be placed over the top of the rock to prevent soil from moving into the rock. The soil backfill should be carefully crowned to fill the trench cavity at a height to allow for settling. Before leaving the site, the area around the site should be graded to divert surface runoff from the area. All soil depressions over the system should be eliminated, and the area should be seeded and mulched. Post construction activities include accurate documentation of all of the system components and the system location. Flag off the infiltration area to keep construction and other traffic away.

### **Construction Practice and Examples**

The BMPs provide guidance on siting a system and regulations that apply to system design and installation.

Charlestown, Rhode Island, subdivision regulations and zoning ordinances establish special standards for wastewater system siting and installation, including policies for the protection of sensitive resources. The required environmental analysis within the subdivision regulations incorporates the consideration of effluent dispersal into the soil and factors related to dispersal sites, such as soil type, slopes, and proximity to waterbodies and wetlands.

The Kansas Department of Health has developed a comprehensive bulletin that specifies minimum standards for the design and construction of individual soil-discharging wastewater systems

New Hampshire created an “Onsite Wastewater Disposal Installation Manual” in 2002. Its purpose is to help both new and experienced system installers and excavators by providing needed and helpful information to properly site and install a state-approved system design. Topics covered in the manual include Installing Systems Consistent with Designer’s Plans, Understanding Designer’s Intent, Estimating Construction Costs, and Assuring Proper Site Layout. All installers must be permitted in New Hampshire, and the manual provides useful information to prepare for the installer’s exam, a necessary step to qualify for an installer’s license.

### **Management Considerations**

All onsite management programs should carefully consider construction and installation elements to ensure the proper operation of onsite systems. These programs should include permits, inspections, and installer training requirements.

### **Construction/Installation Programs Basic Approach**

Construction permit based on code-compliant site evaluations and system design.

- ✓ Installation by trained or certified installers.
- ✓ Inspection of systems prior to backfilling to confirm that installation complies with design.

### **Intermediate Approach**

Pre-construction meeting at site with owner and installer to review construction/installation issues.

- ✓ Certification/licensing requirements for installers.
- ✓ Construction oversight for all critical steps (e.g., field verification and staking of system components, inspections after backfilling, and installation completion).

## **Advanced Approach**

Supplemental training for installers for difficult sites and advanced technologies.

- ✓ Verification and database entry of as-built drawings and other installation information before construction can begin. After determining that the facility design will conform to the general permit requirements, DEQ issues a construction authorization, giving the applicant two years to build the system before the construction authorization expires.

## **Inspection Qualification**

Installation inspections should be conducted by trained and certified personnel at several stages during the system construction and installation process, if possible. Most state and local wastewater programs require inspector training and certification to maintain a high and consistent level of program performance.

The National Sanitation Foundation (NSF) developed a rigorous NSF Inspector Accreditation Program to test an applicant's knowledge on topics ranging from sewage treatment system design and operation to inspection procedures, safety, and basic tank capacity and other calculations. The National Association for Waste Transporters (NAWT) launched a similar but scaled-down NAWT National Inspector Certification. NAWT maintains a National Directory of Certified Inspectors.

During the construction process, inspections before and after backfilling can help verify compliance with approved construction procedures. If there are insufficient management program resources to conduct these inspections, an approved, independent design professional could be required to oversee installation and certify that it has been conducted and recorded properly. The construction process for soil-discharging systems must be flexible to accommodate weather events, since construction during wet weather may compact soils at the infiltrative surface or otherwise alter soil structure and should be avoided.

Commonly, the local health department will provide a field inspection prior to backfilling the system, after which an occupancy permit is issued. For example, for some counties/States an authorization to construct must be granted by the permitting authority before building can begin. This authorization includes specific instructions on the number and schedule of inspections and at what stages of construction the inspections are required.

## **Inspections State and Local Examples**

Some counties/States requires a system "pre-cover-up" inspection unless waived by the county wastewater management agent. Some enhanced systems, such as sand filter systems, require inspections at various stages of construction, and these inspection requirements are specified in the permit. To initiate the pre-cover-up inspection, the installer must complete the As-Built Drawing and Materials List form and submit then to the county. This form must be signed by the installer certifying that it was installed according to specifications.

Some counties/States requires that the designer of county-approved, enhanced systems also be responsible for the system installation inspection to assure conformance with approved plans.

The construction inspection by the designer is in addition to the standard county inspection.

The responsible management entity (RME) for Shannon City, Iowa, provides oversight throughout the construction process either with their own trained and certified personnel or through the USDA Rural Development staff. Final pre-cover inspection and permitting is performed by the Union County Sanitarian.

### **Installer Training and Certification**

Several states require certification of individuals who install individual and clustered wastewater systems. However, certification requirements vary significantly across the country, with some requiring extensive training and others simply mandating registration.

National Onsite Wastewater Recycling Association (NOWRA) recommends that all wastewater system service providers, including installers, be certified. The NOWRA Installer Academy provides skill and technical knowledge training for system technicians.

The National Environmental Health Association, through a cooperative agreement with EPA, has worked with various groups to develop a national credential to certify installers of individual wastewater treatment systems. The credential covers all forms of installation and is offered at both a basic and advanced levels.

The credential is designed to test the knowledge, skills, and abilities needed for the successful installation of a wastewater treatment system. State and local codes are not covered through this national credential, and it is meant to enhance, not replace, a state or local regulatory program. The Consortium of Institutes for Decentralized Wastewater Treatment has also created a series of training modules that include installation/construction for use in training centers.



## Construction Phases

Construction/installation management of a wastewater system can be divided into the following four basic phases:

### 1. Preparation Phase

- ✓ Conduct a pre-construction conference at the site to identify site component locations, verify setbacks and other site conditions, check surface elevations, and identify potential problems or safety concerns (e.g., overhead electric lines).
- ✓ Assess changes in conditions (e.g., soils, topography, vegetation) that may have occurred since design work was completed.
- ✓ If work will be delayed, flag off or otherwise protect the infiltration area.
- ✓ Modify design components or layout, if appropriate.

### 2. Project Execution

- ✓ Verify designed treatment system components and materials, such as tank type, size, and material; piping; and gravel (if used) that is free of fines.
- ✓ Excavate areas for conveyance piping, the tank(s), secondary treatment units, and infiltration or soil dispersal components according to designated depths and required pipe slopes.
- ✓ Use caution to avoid contact with power lines and excavation cave-ins!
- ✓ For gravity flow systems, all elevations are tied to the building sewer line elevation. Ensure that the proper fall is available from the building to the tank, then to the distribution box(es), and to the infiltration area.
- ✓ Ensure that the tank is on solid tamped ground, installed level and at the proper elevation, and that inlet/outlet orientation is correct. Secure tank covers after hours to prevent accidents. Backfill tanks as soon as possible.
- ✓ Follow manufacturer's recommendations for installing tanks. Plastic and fiberglass tanks usually require special installation techniques (e.g., anchoring, backfilling with sand, tamping backfill in lifts, filling tank with water as its backfilled, etc.)
- ✓ Use proper primer and glue for plastic piping. Attach electric lines and control wiring in accordance with design plans as appropriate.
- ✓ Ensure that pumps are plumbed, wired, and installed to allow easy inspection, access, and removal (e.g., use quick-connect union and backflow prevention valve between pump and uphill dispersal piping).
- ✓ Ensure that trench bottoms for gravity flow pipes are tamped and stable and free of rocks and roots, and that backfilled areas around pipes are tamped to prevent dips and rises that could impede flow.
- ✓ Ensure that distribution pipe effluent dispersal holes go on the bottom.
- ✓ Extend inlet and outlet piping stubs below tank access ports, but do not block ports to ensure access for pumping and inspection. Use rubber boots or grout to completely seal around pipes and risers.
- ✓ Install access port risers to the surface, install outlet filters/screens, and complete installation of pumps, wiring, control panels, and other components.
- ✓ Install cleanouts and inspection ports in key locations (near building sewer, D-box, etc.); this aids in operation/maintenance later on.
- ✓ Conduct functional test of the system after installation, checking flows, pump discharge (if used), operation of float switches (if used), and controls.
- ✓ Verify designed component finished conditions (e.g., tank type/capacity, riser covers, elevations, location of key components, drainage, landscaping)

### **3. Final Inspection**

Observe system components prior to cover-up; determine consistency between design and actual installation; report inconsistencies

### **4. Post Construction**

- ✓ Prepare a scaled and dimensioned as-built drawing.
- ✓ Record the materials and equipment used to meet the specifications that were established in the design.
- ✓ Verify that any changes during construction are consistent with the design intent and are of similar or equivalent specification.
- ✓ Record operating parameters for pumps, electronic controllers, hydraulic controllers, and other devices.

### **Soil Permeability" refers to the ability of a soil to transmit water or air.**

Soil with Rapid or Very Rapid Permeability means:

- (a) Soil that contains 35 percent or more of coarse fragments 2 millimeters in diameter or larger by volume with interstitial soil of sandy loam texture or coarser;
- (b) Coarse textured soil defined as loamy sand or sand in this rule; or
- (c) Stones, cobbles, gravel, and rock fragments with too little soil material to fill interstices larger than 1 millimeter in diameter.

## Soil Investigation Parameters Section

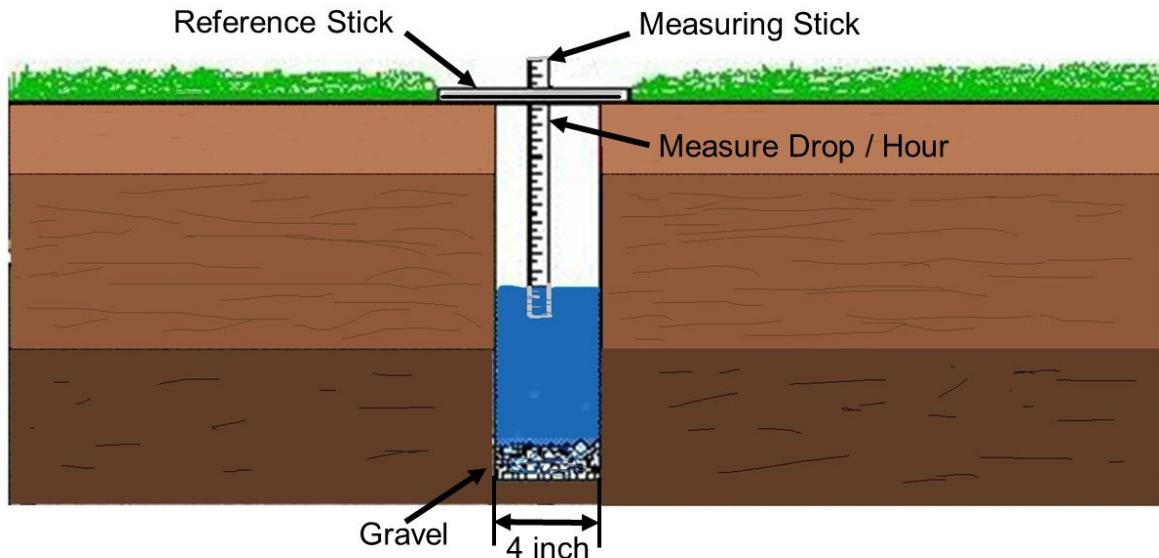

## MEASUREMENT OF PERCOLATION RATE

### Soil Profile

A soil profile evaluation typically includes an analysis of soil texture, color, structure, consistence, and layers within the area of the proposed dispersal field. Soil borings and pits are used to assess soil properties and identify any limiting or restrictive conditions such as rock layers, poor drainage, high water table, or saturated conditions. An ideal soil profile for a dispersal field is at least four feet of well-drained, aerated soil above any limiting conditions such as bedrock, hardpan, or a water table.

Soil Separation	Particle Size Diameter (mm)	Permeability	Permeability Rate/Percolation Rate (inches/hour)	Permeability (gal/day/ft <sup>2</sup> soil area)
Clay	Below 0.002	Very slow	Less than 0.05	0.025
Silt	0.05-0.002	Slow	0.05-0.2	0.5
Very fine sand	0.10-0.05	Moderately slow	0.2-0.8	50
Fine sand	0.25-0.10	Moderate	0.8-2.5	100
Medium sand	0.5-0.25	Moderately rapid	2.5-5.0	250
Coarse sand	1.0-0.5	Rapid	5.0-10.0	2500
Very coarse sand	2.0-1.0	Very rapid	10.0 and over	>2500



## SOIL PERMEABILITY RATES

## Soil Texture

Soil Texture" means the amount of each soil separate in a soil mixture. Field methods for judging the texture of a soil consist of forming a cast of soil, both dry and moist, in the hand and pressing a ball of moist soil between thumb and finger.

(a) The major textural classifications are defined as follows and shown in Table 6 [Note: All tables are found in OAR 340-071-0800.]:

(A) Sand: Individual grains can be seen and felt readily. Squeezed in the hand when dry, this soil will fall apart when the pressure is released. Squeezed when moist, it will form a cast that will hold its shape when the pressure is released but will crumble when touched.

(B) Loamy Sand: Consists primarily of sand, but has enough silt and clay to make it somewhat cohesive. The individual sand grains can readily be seen and felt. Squeezed when dry, the soil will form a cast that will readily fall apart, but if squeezed when moist, a cast can be formed that will withstand careful handling without breaking.

(C) Sandy Loam: Consists largely of sand, but has enough silt and clay present to give it a small amount of stability. Individual sand grains can be readily seen and felt. Squeezed in the hand when dry, this soil will readily fall apart when the pressure is released. Squeezed when moist, it forms a cast that will not only hold its shape when the pressure is released but will withstand careful handling without breaking. The stability of the moist cast differentiates this soil from sand.

(D) Loam: Consists of an even mixture of the different sizes of sand and of silt and clay. It is easily crumbled when dry and has a slightly gritty, yet fairly smooth feel. It is slightly plastic. Squeezed in the hand when dry, it will form a cast that will withstand careful handling. The cast formed of moist soil can be handled freely without breaking.

(E) Silt Loam: Consists of a moderate amount of fine grades of sand, a small amount of clay, and a large quantity of silt particles. Lumps in a dry, undisturbed state appear quite cloddy, but they can be pulverized readily; the soil then feels soft and floury. When wet, silt loam runs together in puddles. Either dry or moist, casts can be handled freely without breaking. When a ball of moist soil is passing between thumb and finger, it will not press out into a smooth, unbroken ribbon but will have a broken appearance.

(F) Clay Loam: Consists of an even mixture of sand, silt, and clay that breaks into clods or lumps when dry. When a ball of moist soil is pressed between the thumb and finger, it will form a thin ribbon that will readily break, barely sustaining its own weight. The moist soil is plastic and will form a cast that will withstand considerable handling.

(G) Silty Clay Loam: Consists of a moderate amount of clay, a large amount of silt, and a small amount of sand. It breaks into moderately hard clods or lumps when dry. When moist, a thin ribbon or 1/8-inch wire can be formed between thumb and finger that will sustain its weight and will withstand gentle movement.

(H) Silty Clay: Consists of even amounts of silt and clay and very small amounts of sand. It breaks into hard clods or lumps when dry. When moist, a thin ribbon or 1/8 inch or smaller wire formed between thumb and finger will withstand considerable movement and deformation.

(I) Clay: Consists of large amounts of clay and moderate to small amounts of sand and silt. It breaks into very hard clods or lumps when dry. When moist, a thin, long ribbon or 1/16-inch wire can be molded with ease. Fingerprints will show on the soil, and a dull to bright polish is made on the soil by a shovel.

(b) Soil textural characteristics described in the United States Department of Agriculture Textural Classification Chart are incorporated here by reference. This textural classification chart is based on the Standard Pipette Analysis as defined in the United States Department of Agriculture, Soil Conservation Service Soil Survey Investigations Report No. 1.

## Sampling Soils

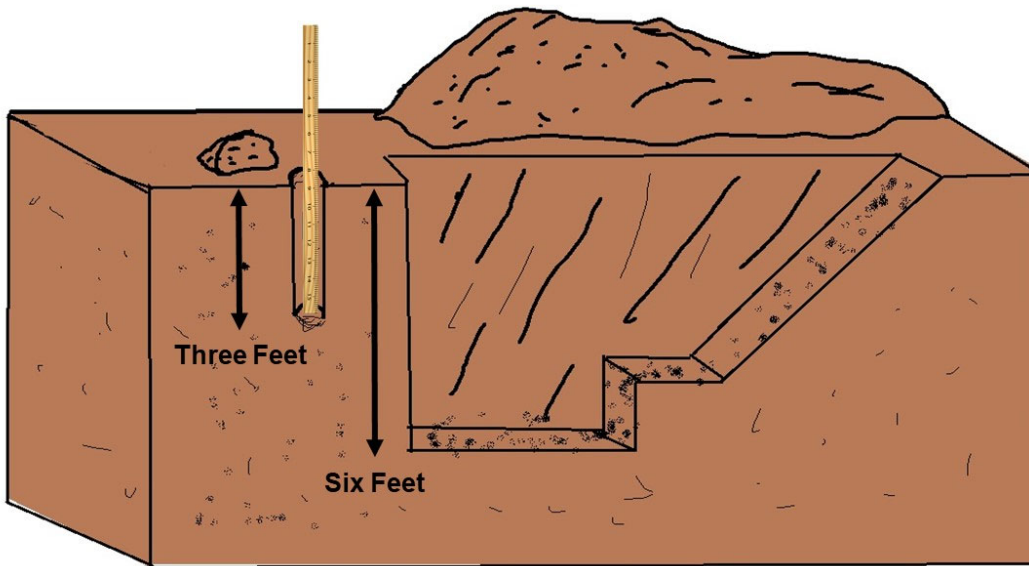

## PERCOLATION TEST

### Percolation Tests

Local health departments have long used percolation or “perc” tests, to determine the loading rate and size of the soil dispersal area, despite some significant shortcomings.

A percolation test consists of digging one or more holes in the soil of the proposed dispersal field to a specified depth, presoaking the holes by maintaining a high water level in the holes, then completing the test by filling the holes to a specific level and timing and measuring the water level drop as the water percolates into the surrounding soil. There are various empirical formulae for determining the required size of a drainfield based on the size of facility, the percolation test results, and other parameters.

Many states and communities have written this test into their onsite ordinances, statutes, or building codes. Maryland and a number of other states also require the use of percolation tests and site evaluations for repairs to existing septic systems that are malfunctioning.

A percolation test, however, has limitations. The test does not reveal limiting conditions in the soil profile and can provide false readings during dry conditions, leading to an inappropriately high loading rate.

States and communities once relied solely on these tests to determine effluent application rates. However, the limitations of the test have caused many state and local agencies to either eliminate this test altogether or to require additional tests that must be conducted during a site evaluation to determine limiting site conditions and to estimate allowable hydraulic loading rates.

## Site Evaluation Reports

Site evaluation reports provide essential information for treatment system selection, design, sizing, and siting. Many states and communities, such as Harris County, Texas, have developed forms to assist in the collection of site evaluation data. North Carolina's soil evaluation form details soil morphology and other soil profile factors. In Oregon, a site evaluation application form must include a tax lot map, a detailed drawing of the proposed development, and directions to the property. Oregon's requirement for soil test pits are provided with the site evaluation information packet and is used by the regulatory agency to generate a site evaluation report that typically specifies the approved area, the type and size of the system required, and any other requirements.

Some communities have created their own databases to assist in the site evaluation process. Fairfax County, Virginia, mapped its soils and uses its database to verify site evaluation assessments of new proposed systems. If the soil evaluation data is consistent with the county's database and the proposed design meets requirements, a construction permit is granted. If the site evaluation is inconsistent with the soil information collected by the county, further investigation will be required from the applicant.

The Georgetown Divide Public Utility District in California has conducted detailed site evaluations for 965 lots using 4,000 test hole samples examined by a soil scientist. Every lot had a designated home site for a three-bedroom home, an effluent dispersal site, a replacement area, and a specified system type. In addition to using this information for designing wastewater treatment systems, the information is used to show trends and other factors that could impact system design.

The Wastewater Information System Tool (TWIST) prepared by EPA provides a typical listing of data collected during the site evaluation process. EPA developed TWIST as a comprehensive inventory and management information system via a Microsoft Access format. TWIST accommodates a wide variety of queries, list reports, and mapping applications. The system software and training/user information are available from the EPA Decentralized Wastewater Management Web site for free download.

## Site Limitations and Special Considerations

In some cases, soil profile or other limitations create challenges for individual and clustered wastewater treatment. Most of these limitations are natural or induced restrictions to soil water and air movement, which limit the depth and duration of unsaturated soil conditions. Identifying these limiting conditions is a critical step in the site evaluation process. Some of the major limitations of concern are:

- ✓ High water tables, with saturated soil conditions present near the soil surface.
- ✓ Restricted soil depth above dense, slowly permeable substratum materials, including unfractured bedrock and dense glacial till.
- ✓ Restricted soil depth above dense, slowly permeable subsurface soil layers, including fragipans, compacted soil, and heavy clay materials.
- ✓ Other layers with inadequate permeability.
- ✓ Poor drainage conditions or flooding.
- ✓ Excessively steep slopes.
- ✓ Presence of excessive amounts of rock in the soil.
- ✓ Fractured bedrock at shallow depths.
- ✓ Sandy soils with excessive permeability.

- ✓ Sand and gravel layers below finer textured soil materials.

If a site does not demonstrate acceptable permeability or has other limiting factors that preclude the use of conventional treatment systems, some states and communities will allow the landowner to consult with an engineer to design an alternative or advanced system that can overcome a site's restrictive soil and site limitations.

### **Fixed Film and Suspended Growth Advanced Treatment Systems**

Fixed film and suspended growth advanced treatment systems provide an effluent of higher quality than conventional septic tank discharges. Higher levels of treatment allow marginal soils to more easily absorb and treat wastewater. However, these systems require more attention to design requirements, material selection, and construction detail.

Regular operation and maintenance attention for these systems is critical to maintaining performance and ensuring system operation over the long term. The site evaluator needs to understand and analyze all of these critical factors when recommending an alternative or advanced treatment system.

Several additional site evaluation factors may also need to be considered when planning large wastewater treatment systems or clustered facilities. EPA defines a large capacity septic system as a system that has the capacity to serve 20 or more people per day. Clustered wastewater systems, as discussed in the Cluster Wastewater Systems Planning Handbook, can serve a small to large number of connections (two to hundreds of structures).

Smaller cluster systems serving a few structures can be gravity flow facilities that resemble individual systems, while larger cluster systems serving hundreds of structures are often highly mechanized with extensive collection piping, and tend to resemble centralized systems. Regular, permanent operation and maintenance of these systems is required by regulatory authorities.

As with conventional systems, sites proposed for soil-discharging cluster systems must be evaluated for water table elevations, shallow aquifers, land slope, soil texture, and permeability. There are also a number of other factors that can have a long-term impact on the operation and use of a large system.

For example, road and sewer development needs to be coordinated with system siting and construction. The location of the sewage treatment site needs to fit with the overall physical plan of the development. Areas reserved for future development need to be clearly identified, and the proposed wastewater treatment needs to fit with existing plans for open space and buffers around a development.

### **Soil Absorption Systems**

In large cluster or soil absorption systems where increased quantities of wastewater will be dispersed, other factors must also be evaluated, such as the potential for groundwater mounding.

These systems may experience artificial groundwater mounding under the drainfield due to the large wastewater contribution, restrictive soil layers, and other hydrogeologic conditions. Both the Hantush Method and MODFLOW are acceptable groundwater flow models that can be used to characterize more complicated sites.

Methodologies to evaluate site conditions and system design influences on the potential for groundwater mounding and lateral spreading can also be found in Guidance for Evaluation of

## Potential Groundwater Mounding Associated with Cluster and High-Density Wastewater Soil Absorption Systems.

Some states specify additional evaluations based on the risk posed. For example, the Idaho Department of Environmental Quality requires nutrient and pathogen evaluations for all large soil absorption systems (defined as systems with wastewater generation rates exceeding 2,500 gallons per day) located in nitrate priority areas or in areas of “sensitive resource” aquifers (e.g. the Spokane Valley-Rathdrum Prairie aquifer). The nutrient/pathogen evaluation refers to a set of activities that includes the compilation of existing information, collection of site-specific information, and the completion of predictive contaminant fate and transport modeling for groundwater.



## System Design Standards and Practices Sub-Section

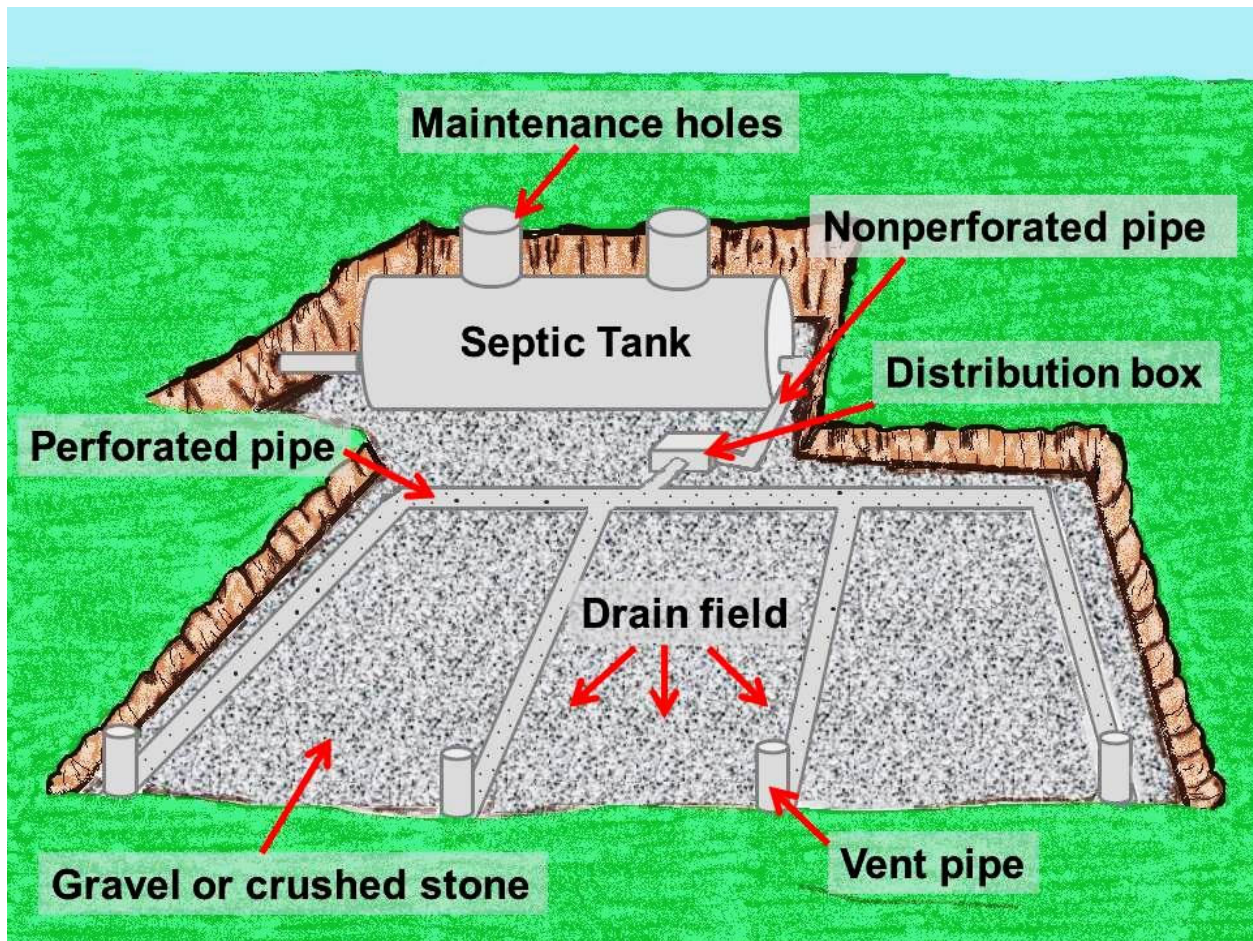

Effluent flows directly from your household plumbing into a watertight, underground, two compartment septic tank. Solid waste settles into a sludge layer on the bottom and fats float to the top of the first compartment. Between these two scum layers is a zone of clarified liquid effluent which is internally piped to the second compartment of the septic tank for additional settling.

As incoming sewage from the house fills first compartment, clarified liquids are forced to leave the second chamber of the septic tank and flow out to the leach field or leach pit. The typical leach field is a series of chambers or rock filled trenches where effluent is further treated as it slowly percolates through the soil.

A leach pit is a deeper, larger hole filled with rock for disposing of wastewater in a smaller footprint.

Not as effective treatment as a larger leach field, where sewage percolates slowly over a larger area, leach pits are an alternative for smaller properties only where high seasonal ground water is not present. Greywater from washing machine, sinks and showers contains soaps designed to kill bacteria (clean and disinfect things) and thus discourage optimal septic tank function.

You want to encourage helpful *good* bacteria (digesting anaerobic cultures) to grow in your customer's septic tank and organically treat the waste, not kill helpful bacteria with detergent laden graywater. If allowed by local building department, it is best practice to divert household greywater to a separate leaching area.

Nearly all states and some local governments have regulatory or guidance documents detailing acceptable design approaches for individual and clustered wastewater treatment systems. For example, Minimum Standards for the Design and Construction of Wastewater Systems, lists the following five elements of septic tank–lateral field system design:

- ✓ Wastewater flow
- ✓ Soil and site evaluation
- ✓ Septic tank standards for design, construction, and installation
- ✓ Lateral field design and construction
- ✓ System maintenance

## Septic System Design: *The Basics*

**Site Evaluation:** There are two considerations to "perc test" or site evaluation: 1) the soil type and 2) projected sewage usage. To determine your projected sewer usage, please check with your local health department or regulator agency. Please note: the site evaluation is done with a backhoe.

**Soil Classification:** Soil classification is determined by the US Department of Agriculture Soil Conservation Classification System. The importance of soil classification should not be underestimated. If the soil is inaccurately classified, it could cause unnecessary delays and expense. Please consult with a soil expert before proceeding with your septic system design project. We will cover this area later in the course.

**Designing a Septic System:** Hire a septic system design engineer to design a septic system based on your house or building's plan; this will help to ensure that the septic system design meets all local regulations.

**Department of Health Evaluation:** In most states, the Department of Health is the agency that regulates septic systems. This agency also reviews and approves and/or denies septic system design plans. The engineer that designed your septic system will have to not only submit the designs, but also the soil classification results and the "perc test" or site evaluation in order for the plans to be considered for approval.

**Approval:** Congratulations! Your septic system design has been approved. If you followed the proper septic system design procedures, you should hear those words. If approved, the septic system engineer should give you a copy of the approved designs. Now you have a basic understanding of the process for designing a septic system.

## Perc Condition Terms Associated with Saturation

**Conditions Associated with Saturation:** Means soil morphological properties that may indicate the presence of a water table that persists long enough to impair system function and create a potential health hazard. These conditions include depleted matrix chromas caused by saturation and not a relict or parent material feature, and the following:

**High Chroma Matrix with Iron Depletions:** Soil horizons whose matrix chroma is 3 or more in which there are some visible iron depletions having a value 4 or more and a chroma of 2 or less. Iron-manganese concentrations as soft masses or pore linings may be present but are not diagnostic of conditions associated with saturation.

**Depleted Matrix with Iron Concentrations:** Soil horizons whose matrix color has a value of 4 or more and a chroma of 2 or less as a result of removal of iron and manganese oxides. Some visible zones of iron concentration are present as soft masses or pore linings.

**Depleted Matrix without Iron Concentrations:** Soil horizons whose color is more or less uniform with a value of 4 or more and a chroma of 2 or less as a result of removing iron and manganese oxides. These horizons lack visible iron concentrations as soft masses or pore linings.

**Reduced Matrix:** Soil horizons whose color has a value of 4 or more and a chroma of 2 or less with hues that are often, but not exclusively, on the grey pages of the Munsell Color Book. On exposure to air, yellow colors form within 24 hours as some of the ferrous iron oxidizes.

**Dark Colored Soils with Organic Matter Accumulation:** Mineral soils with a high amount of decomposed organic matter in the saturated zone, a value of 3 or less, and a chroma of 1 or less. Included in this category are organic soils with a minor amount of mineral matter.

**Soils with a Dark Surface:** The upper surface layer has a dark color with a value of 3 or less and a chroma of 1 or less immediately underlain by a layer with a chroma of 2 or less.

**Iron Stripping and Staining in Sandy Soils:** Soil horizons in which iron/manganese oxides or organic matter or both have been stripped from the matrix, exposing the primary base color of soil materials. The stripped areas and trans-located oxides or organic matter form a diffuse splotchy pattern of two or more colors.

**Salt-Affected Soils:** Soils in arid and semi-arid areas that have visible accumulations of soluble salts at or near the ground surface.

**Dark Colored Shrink-Swell Soils:** Vertisols whose colors have values of 3 or less and chromas of 1 or less. Iron concentrations may be present but are not diagnostic of conditions associated with saturation.

## When is a Soil Perc Test Required vs Performed?

There are two different questions here:

1. **A soil perc test or percolation test is going to be required** in most jurisdictions when a builder or property owner is going to install a new or replacement septic system that requires local health or building department approval. This might be a perc test for a new building site or a perc test to permit approval of a septic design for a replacement soak bed or drainfield at an existing property whose existing septic fields must be replaced.
2. **A soil perc test is usually performed during wet weather** or during the wet season - a time that varies depending on where you live. Typically April-June

### Why Soil Perc Testing during Wet Weather is Important

Why not do our perc tests during the dry season when a site is most likely to "pass" local soil perc test requirements? We have all seen other builders use this trick to pass a marginal site for locating a septic soak bed.

Unfortunately designing a septic effluent disposal system based on "dry season" perc testing results means that the septic system design is likely to be inadequate: that is, during the wet season when soil water tables are higher and perc rates are slower, the septic system is going to discharge un-treated effluent into the environment: basically your are discharging raw sewage into the water supply.

## Septic Tank Construction Considerations

Important construction considerations include tank location, bedding and backfilling, watertightness, and flotation prevention, especially with non-concrete tanks. Roof drains, surface water runoff, and other clear water sources must not be routed to the septic tank. Attention to these considerations will help to ensure that the tank performs as intended.

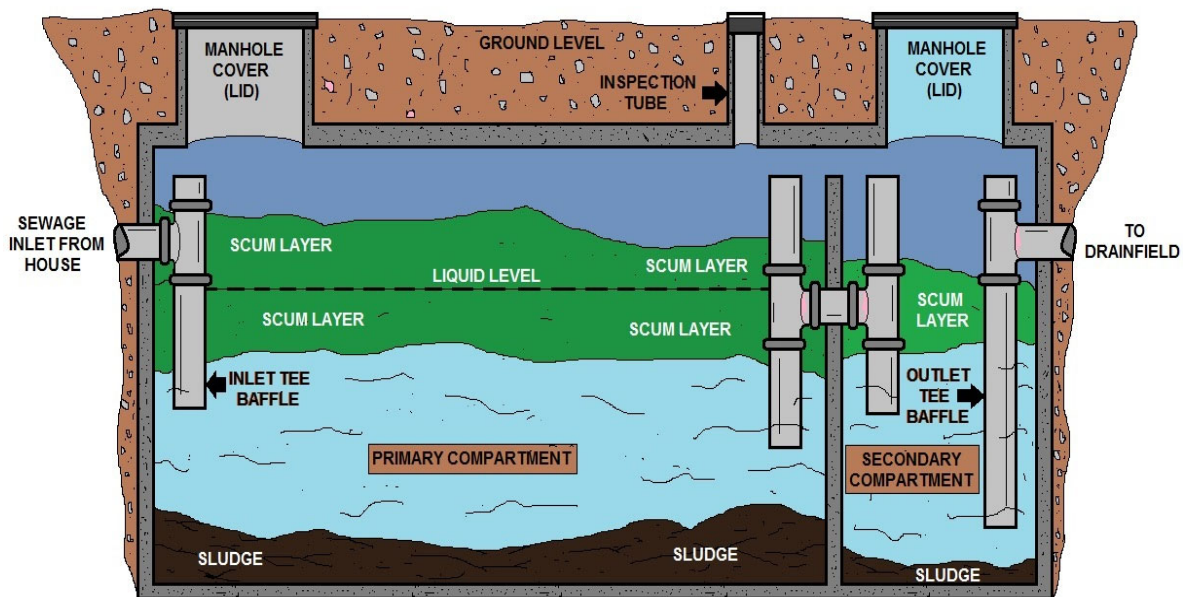

COMPONENTS OF A SEPTIC TANK SYSTEM

## Construction Materials

Septic tanks smaller than 6,000 gallons are typically pre-manufactured; larger tanks are constructed in place. The materials used in pre-manufactured tanks include concrete, fiberglass, polyethylene, and coated steel. Precast concrete tanks are by far the most common, but fiberglass and plastic tanks are gaining popularity. The lighter weight fiberglass and plastic tanks can be shipped longer distances and set in place without cranes.

Concrete tanks, on the other hand, are less susceptible to collapse and flotation.

Coated steel tanks are no longer widely used because they corrode easily. Tanks constructed in place are typically made of concrete.

Tanks constructed of fiberglass/reinforced polyester (FRP) usually have a wall thickness of about 1/4 inch (6 millimeters). Most are gel or resin coated to provide a smooth finish and prevent glass fibers from becoming exposed, which can cause wicking.

Polyethylene tanks are more flexible than FRP tanks and can deform to a shape of structural weakness if not properly designed. Concrete tank walls are usually about 4 inches thick and reinforced with no. 5 rods on 8-inch centers.

Sulfuric acid and hydrogen sulfide, both of which are present in varying concentrations in septic tank effluent, can corrode exposed rods and the concrete itself over time. Some plastics (e.g., polyvinyl chloride, polyethylene, but not nylon) are virtually unaffected by acids and hydrogen sulfide (USEPA, 1991).

Quality construction is critical to proper performance.

Tanks must be properly designed, reinforced, and constructed of the proper mix of materials so they can meet anticipated loads without cracking or collapsing. All joints must be watertight and flexible to accommodate soil conditions. For concrete tank manufacturing, a "best practices manual" can be purchased from the National Pre-Cast Concrete Association (NPCA, 1998). Also, a Standard Specification for Precast Concrete Septic Tanks (C 1227) has been published by the American Society for Testing and Materials (ASTM, 1998).

## Watertightness

Watertightness of the septic tank is critical to the performance of the entire onsite wastewater system. Leaks, whether exfiltrating or infiltrating, are serious. Infiltration of clear water to the tank from the building storm sewer or ground water adds to the hydraulic load of the system and can upset subsequent treatment processes.

Exfiltration can threaten ground water quality with partially treated wastewater and can lower the liquid level below the outlet baffle so it and subsequent processes can become fouled with scum. In addition, leaks can cause the tank to collapse.

Tank joints should be designed for watertightness. Two-piece tanks and tanks with separate covers should be designed with tongue and groove or lap joints.

Manway covers should have similar joints. High-quality, preformed joint sealers should be used to achieve a watertight seal. They should be workable over a wide temperature range and should adhere to clean, dry surfaces; they must not shrink, harden, or oxidize.

Seals should meet the minimum compression and other requirements prescribed by the seal manufacturer. Pipe and inspection port joints should have cast-in rubber boots or compression seals.

Septic tanks should be tested for watertightness using hydrostatic or vacuum tests, and manway risers and inspection ports should be included in the test. The professional association representing the materials industry of the type of tank construction (e.g., the National Pre-cast Concrete Association) should be contacted to establish the appropriate testing criteria and procedures.

### Watertightness Testing Procedure/Criteria for Precast Concrete Tanks Table

Standard	Hydrostatic test		Vacuum test	
	Pass/fail criterion	Preparation	Preparation	Pass/fail criterion
C 1227, ASTM (1993)	Seal tank, fill with water, and let stand for 24 hours. Refill tank.	Approved if water level is held for 1 hour	Seal tank and apply a vacuum of 2 in. Hg.	Approved if 90% of vacuum is held for 2 minutes.
NPCA (1998)	Seal tank, fill with water, and let stand for 8 to 10 hours. Refill tank and let stand for another 8 to 10 hours.	Approved if no further measurable water level drop occurs	Seal tank and apply a vacuum of 4 in. Hg. Hold vacuum for 5 minutes. Bring vacuum back to 4 in. Hg.	Approved if vacuum can be held for 5 minutes without a loss of vacuum.

## Location

The tank should be located where it can be accessed easily for septage removal and sited away from drainage swales or depressions where water can collect. Local codes must be consulted regarding minimum horizontal setback distances from buildings, property boundaries, wells, water lines, and the like.

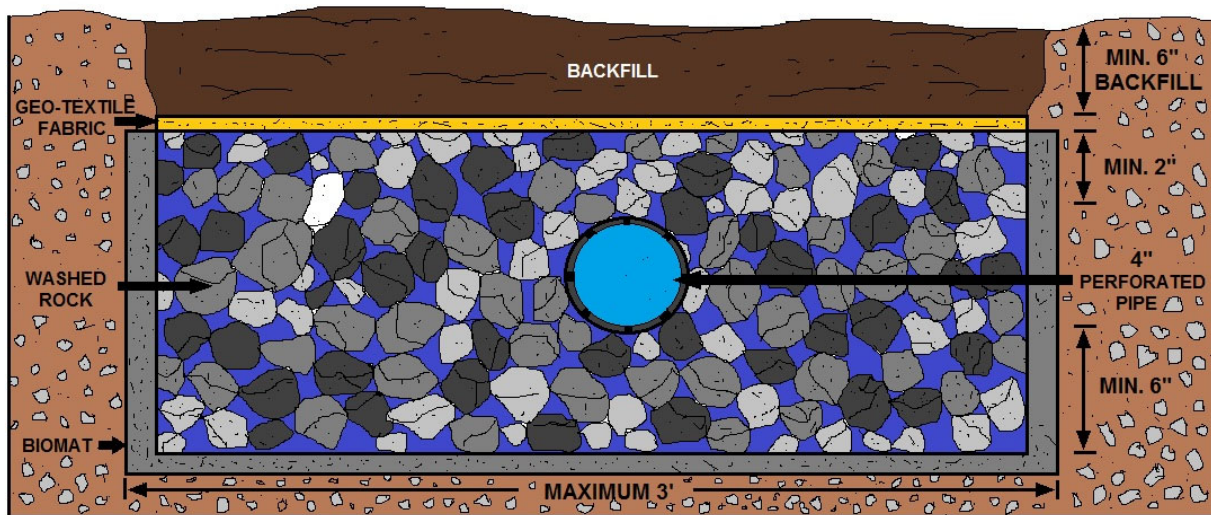

## SEPTIC TANK SYSTEM DRAINAGE PIPING

### Bedding and Backfilling

The tank should rest on a uniform bearing surface. It is good practice to provide a level, granular base for the tank. The underlying soils must be capable of bearing the weight of the tank and its contents. Soils with a high organic content or containing large boulders or massive rock edges are not suitable.

After setting the tank, leveling, and joining the building sewer and effluent line, the tank can be backfilled. The backfill material should be free-flowing and free of stones larger than 3 inches in diameter, debris, ice, or snow. It should be added in lifts and each lift compacted. In fine-textured soils such as silts, silt loams, clay loams, and clay, imported granular material should be used. This is a must where freeze and thaw cycles are common because the soil movement during such cycles can work tank joints open. This is a significant concern when using plastic and fiberglass tanks.

The specific bedding and backfilling requirements vary with the shape and material of the tank. The manufacturer should be consulted for acceptable materials and procedures.

### Joint Watertightness

All joints must be sealed properly, including tank joints (sections and covers if not a monolithic tank), inlets, outlets, manways, and risers (ASTM, 1993; NPCA, 1998). The joints should be clean and dry before applying the joint sealer. Only high-quality joint sealers should be used (see previous section).

Backfilling should not proceed until the sealant setup period is completed. After all joints have been made and have cured, a watertightness test should be performed. Risers should be tested.



### **Flotation Prevention**

If the tank is set where the soil can be saturated, tank flotation may occur, particularly when the tank is empty (e.g., recently pumped dose tanks or septic tank after septage removal). Tank manufacturers should be consulted for appropriate anti-flotation devices.

### **Design Considerations**

Onsite wastewater treatment system designs vary according to the site and wastewater characteristics encountered. However, all designs should strive to incorporate the following features to achieve satisfactory long-term performance:

1. Shallow placement of the infiltration surface (< 2 feet below final grade)
2. Organic loading comparable to that of septic tank effluent at its recommended hydraulic loading rate
3. Trench orientation parallel to surface contours
4. Narrow trenches (< 3 feet wide)
5. Timed dosing with peak flow storage
6. Uniform application of wastewater over the infiltration surface
7. Multiple cells to provide periodic resting, standby capacity, and space for future repairs or replacement. Based on the site characteristics, compromises to ideal system designs are necessary. However, the designer should attempt to include as many of the above features as possible to ensure optimal long-term performance and minimal impact on public health and environmental quality.

### **Placement of the Infiltration Surface**

Placement of a SWIS infiltration surface may be below, at, or above the existing ground surface (in an in-ground trench, at grade, or elevated in a mound system).

Actual placement relative to the original soil profile at the site is determined by desired separation from a limiting condition. Treatment by removal of additional pollutants during movement through soils and the potential for excessive ground water mounding will control the minimum separation distance from a limiting condition.

The depth below final grade is affected by subsoil reaeration potential. Maximum delivery of oxygen to the infiltration zone is most likely when soil components are shallow and narrow and have separated infiltration areas. (Erickson and Tyler, 2001).

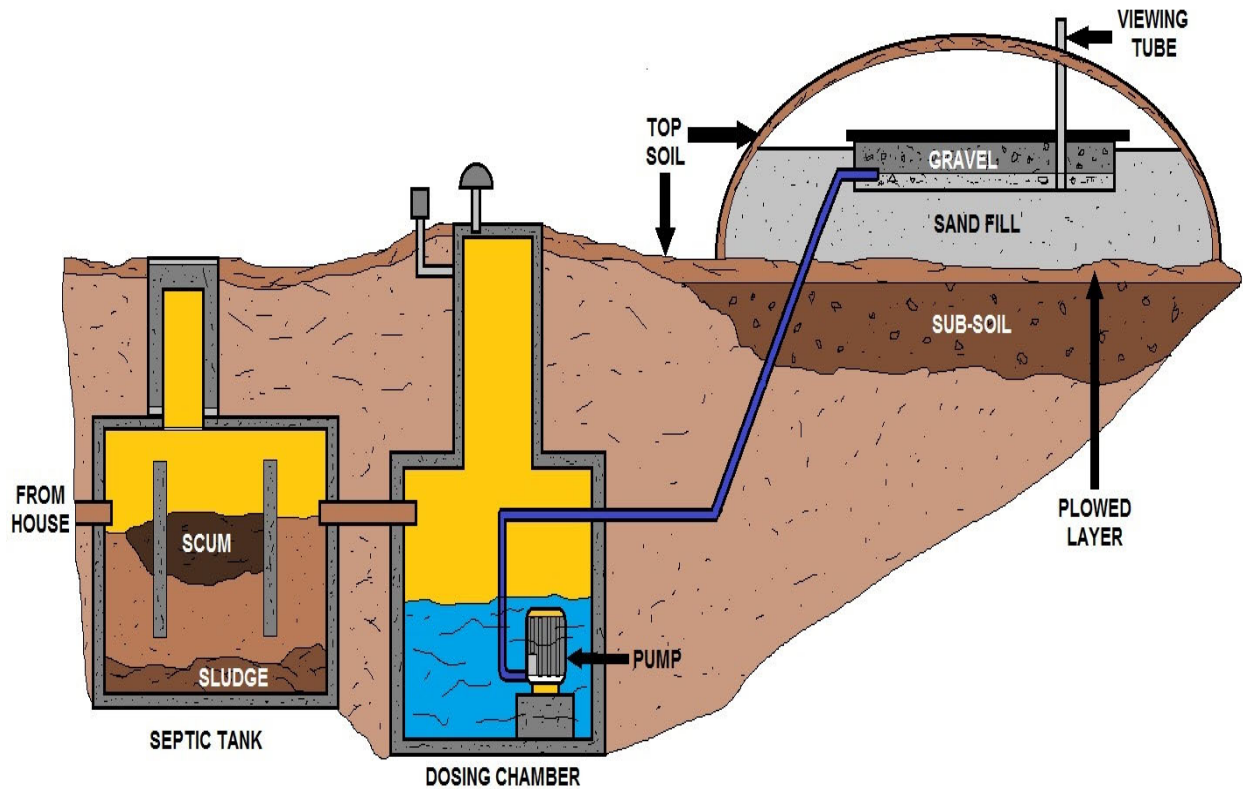

## ABOVE GRADE TREATMENT SYSTEM (Mound System)

Few governmental programs address onsite system operation and maintenance, resulting in failures that lead to unnecessary costs and risks to public health and water resources. Moreover, the lack of coordination among agencies that oversee land use planning, zoning, development, water resource protection, public health initiatives, and onsite systems causes problems that could be prevented through a more cooperative approach.

Effective management of onsite systems requires rigorous planning, design, installation, operation, maintenance, monitoring, and controls.

## Separation Distance from a Limiting Condition

Placement of the infiltration surface in the soil profile is determined by both treatment and hydraulic performance requirements. Adequate separation between the infiltration surface and any saturated zone or hydraulically restrictive horizon within the soil profile must be maintained to achieve acceptable pollutant removals, sustain aerobic conditions in the subsoil, and provide an adequate hydraulic gradient across the infiltration zone.

Treatment needs (performance requirements) establish the minimum separation distance, but the potential for ground water mounding or the availability of more permeable soil may make it advantageous to increase the separation distance by raising the infiltration surface in the soil profile.

Most current onsite wastewater system codes require minimum separation distances of at least 18 inches from the seasonally high water table or saturated zone irrespective of soil characteristics.

Generally, 2 to 4 foot separation distances have proven to be adequate in removing most fecal coliforms in septic tank effluent (Ayres Associates, 1993). However, studies have shown that the applied effluent quality, hydraulic loading rates, and wastewater distribution methods can affect the unsaturated soil depth necessary to achieve acceptable wastewater pollutant removals.

A few studies have shown that separation distances of 12 to 18 inches are sufficient to achieve good fecal coliform removal if the wastewater receives additional pretreatment prior to soil application (Converse and Tyler, 1998a, 1998b; Duncan et al., 1994).

However, when effluents with lower organic and oxygen-demanding content are applied to the infiltration surface at greater hydraulic loading rates than those typically used for septic tank effluents (during extended periods of peak flow), treatment efficiency can be lost (Converse and Tyler, 1998b, Siegrist et al., 2000).

### **Reducing the Hydraulic Loading Rate**

Reducing the hydraulic loading rate or providing uniform distribution of the septic tank effluent has been shown to reduce the needed separation distance (Bomblat et al., 1994; Converse and Tyler, 1998a; Otis, 1985; Siegrist et al., 2000; Simon and Reneau, 1987). Reducing both the daily and instantaneous hydraulic loading rates and providing uniform distribution over the infiltration surface can help maintain lower soil moisture levels.

Lower soil moisture results in longer wastewater retention times in the soil and causes the wastewater to flow through the smaller soil pores in the unsaturated zone, both of which enhance treatment and can reduce the necessary separation distance.

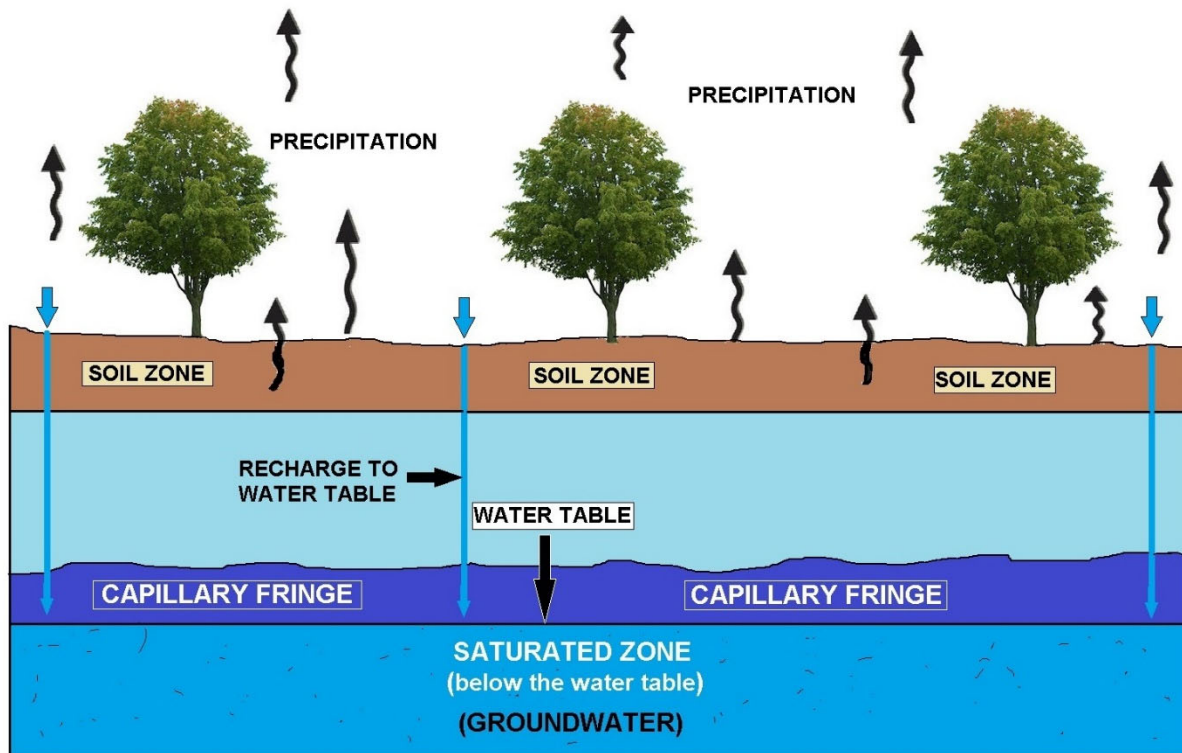

## CAPILLARY FRINGE

(Material above water table that may contain water by capillary pressure in small voids)

Based only on hydraulics, certain soils require different vertical separation distances from ground water to avoid hydrologic interference with the infiltration rate. From a treatment standpoint, required separation distances are affected by dosing pattern, loading rate, temperature, and soil characteristics. Uniform, frequent dosing (more than 12 times/day) in coarser soils maximizes the effectiveness of biological, chemical, and physical treatment mechanisms. To offset inadequate vertical separation, a system designer can raise the infiltration surface in an at-grade system or incorporate a mound in the design.

If the restrictive horizon is a high water table and the soil is porous, the water table can be lowered through the use of drainage tile or a curtain drain if the site has sufficient relief to promote surface discharge from the tile piping.

For flat terrain with porous soils, a commercial system has been developed and is being field-tested. It lowers the water table with air pressure, thereby avoiding any aesthetic concerns associated with a raised mound on the site. Another option used where the terrain is flat and wet is pumped drainage surrounding the OWTS (or throughout the subdivision) to lower the seasonal high water table and enhance aerobic conditions beneath the drainfield.

These systems must be properly operated by certified operators and managed by a public management entity since maintenance of off-lot portions of the drainage network will influence performance of the SWIS.

The hydraulic capacity of the site or the hydraulic conductivity of the soil may increase the minimum acceptable separation distance determined by treatment needs. The soil below the infiltration surface must be capable of accepting and transmitting the wastewater to maintain the desired unsaturated separation distance at the design hydraulic loading rate to the SWIS.

The separation distance necessary for satisfactory hydraulic performance is a function of the permeability of the underlying soil, the depth to the limiting condition, the thickness of the saturated zone, the percentage of rocks in the soil, and the hydraulic gradient.

Groundwater mounding analyses may be necessary to assess the potential for the saturated zone to rise and encroach upon the minimum acceptable separation distance. Raising the infiltration surface can increase the hydraulic capacity of the site by accommodating more mounding.

If the underlying soil is more slowly permeable than soil horizons higher in the profile, it might be advantageous to raise the infiltration surface into the more permeable horizon where higher hydraulic loading rates are possible (Hoover et al., 1991; Weymann et al., 1998).

A shallow infiltration system covered with fill or an at-grade system can be used if the natural soil has a shallow permeable soil horizon (Converse et al., 1990; Penninger, and Hoover, 1998). If more permeable horizons do not exist, a mound system constructed of suitable sand fill can provide more permeable material in which to place the infiltration surface.

### **Depth of the Infiltration Surface**

The depth of the infiltration surface is an important consideration in maintaining adequate subsoil aeration and frost protection in cold climates. The maximum depth should be limited to no more than 3 to 4 feet below final grade to adequately reaerate the soil and satisfy the daily oxygen demand of the applied wastewater. The infiltrative surface depth should be less in slowly permeable soils or soils with higher ambient moisture. Placement below this depth to take advantage of more permeable soils should be resisted because reaeration of the soil below the infiltration surface will be limited.

In cold climates, a minimum depth of 1 to 2 feet may be necessary to protect against freezing. Porous fill material can be used to provide the necessary cover even with an elevated (at-grade or mound) system if it is necessary to place the infiltration surface higher.

### **Subsurface Drainage**

Soils with shallow saturated zones sometimes can be drained to allow the infiltration surface to be placed in the natural soil. Curtain drains, vertical drains, underdrains, and mechanically assisted commercial systems can be used to drain shallow water tables or perched saturated zones. Of the three, curtain drains are most often used in onsite wastewater systems to any great extent. They can be used effectively to remove water that is perched over a slowly permeable horizon on a sloping site.

However, poorly drained soils often indicate other soil and site limitations that improved drainage alone will not overcome, so the use of drainage enhancements must be carefully considered. Any sloping site that is subject to frequent inundation during prolonged rainfall should be considered a candidate for upslope curtain drains to maintain unsaturated conditions in the vadose zone.

Curtain drains are installed upslope of the SWIS to intercept the permanent and perched groundwater flowing through the site over a restrictive horizon.



## Infiltration Surface Loading Limitations

Infiltration surface hydraulic loading design rates are a function of soil morphology, wastewater strength, and SWIS design configuration. Hydraulic loadings are traditionally used to size infiltration surfaces for domestic septic tank effluent. In the past, soil percolation tests determined acceptable hydraulic loading rates.

Codes provided tables that correlated percolation test results to the necessary infiltration surface areas for different classes of soils. Most states have supplemented this approach with soil morphologic descriptions. Morphologic features of the soil, particularly structure, texture, and consistence, are better predictors of the soil's hydraulic capacity than percolation tests (Brown et al., 1994; Gross et al., 1998; Kleiss and Hoover, 1986; Simon and Reneau, 1987; Tyler et al., 1991; Tyler and Converse, 1994).

Although soil texture analysis supplemented the percolation test in most states by the mid-1990s, soil structure has only recently been included in infiltrative surface sizing tables.

Consistence, a measure of how well soils form shapes and stick to other objects, is an important consideration for many slowly permeable soil horizons. Expansive clay soils that become extremely firm when moist and very sticky or plastic when wet (exhibiting firm or extremely firm consistence) are not well suited for SWISs.

Increasingly, organic loading is being used to size infiltration surfaces. Based on current understanding of the mechanisms of SWIS operation, organic loadings and the reaeration potential of the subsoil to meet the applied oxygen demand are critical considerations in successful SWIS design.

Anaerobic conditions are created when the applied oxygen demand exceeds what the soil is able to supply by diffusion through the vadose zone (Otis, 1985, 1997; Siegrist et al., 1986). The facultative and anaerobic microorganisms that are able to thrive in this environment are less efficient in degrading the waste materials. The accumulating waste materials and the metabolic by-products cause soil clogging and loss of infiltrative capacity.

Further, higher forms of soil fauna that would help break up the biomat (e.g., worms, insects, non-wetland plants) and would be attracted to the carbon and nutrient-rich infiltration zone are repelled by the anoxic or anaerobic environment.

If wastewater application continues without ample time to satisfy the oxygen demand, hydraulic failure due to soil clogging occurs. Numerous studies have shown that wastewaters with low BOD concentrations (e.g., < 50 mg/L) can be applied to soils at rates 2 to 16 times the typical hydraulic loading rate for domestic septic tank effluent (Jones and Taylor, 1965; Laak, 1970, 1986; Loudon et al., 1998; Otis, 1985; Siegrist and Boyle, 1987; Tyler and Converse, 1994).

The comparatively higher hydraulic loadings that highly treated wastewater (highly treated in terms of TSS, ammonium/nitrogen, and BOD) may permit should be considered carefully because the resulting rapid flow through the soil may allow deep penetration of pathogens (Converse and Tyler, 1998a, 1998b; Siegrist et al., 2000; Siegrist and Van Cuyk, 2001b; Tyler and Converse, 1994).

**Suggested Hydraulic and Organic Loading Rates for Sizing Infiltration Surfaces Table**

Texture	Structure		Hydraulic loading (gal/ft <sup>2</sup> -day)		Organic loading (lb BOD/1000ft <sup>2</sup> -day)	
	Shape	Grade	BOD=150	BOD=30	BOD=150	BOD=30
Coarse sand, sand, loamy coarse sand, loamy sand	Single grain	Structureless	0.8	1.8	1.00	0.40
Fine sand, very fine sand, loamy fine sand, loamy very fine sand	Single grain	Structureless	0.4	1.0	0.50	0.25
Coarse sandy loam, sandy loam	Massive	Structureless	0.2	0.6	0.25	0.15
	Platy	Weak	0.2	0.5	0.25	0.13
		Moderate, Strong				
	Prismatic, blocky, granular	Weak	0.4	0.7	0.50	0.18
		Moderate, strong	0.6	1.0	0.75	0.25
Fine sandy loam, very fine sandy loam	Massive	Structureless	0.2	0.5	0.25	0.13
	Platy	Weak, mod., strong				
		Weak	0.2	0.6	0.25	0.15
	Prismatic, blocky, granular	Moderate, strong	0.4	0.8	0.50	0.20
		Weak				
Loam	Massive	Structureless	0.2	0.5	0.25	0.13
	Platy	Weak, mod., strong				
		Weak	0.4	0.6	0.50	0.15
	Prismatic, blocky, granular	Moderate, strong	0.6	0.8	0.75	0.20
		Weak				
Silt loam	Massive	Structureless		0.2	0.00	0.05
	Platy	Weak, mod., strong				
		Weak	0.4	0.6	0.50	0.15
	Prismatic, blocky, granular	Moderate, strong	0.6	0.8	0.75	0.20
		Weak				
Sandy clay loam, clay loam, silty clay loam	Massive	Structureless				
	Platy	Weak, mod., strong				
		Weak				
	Prismatic, blocky, granular	Moderate, strong	0.2	0.3	0.25	0.08
		Weak				

Source: Adapted from Tyler, 2000.

The trench length perpendicular to ground water movement (footprint) should remain the same to minimize system impacts on the aquifer. Unfortunately, well-tested organic loading rates for various classes of soils and SWIS design configurations have not been developed. Most organic loading rates have been derived directly from the hydraulic loadings typically used in SWIS design by assuming a BOD5 concentration.



### **Derived Organic Loading Rates**

The derived organic loading rates also incorporate the implicit factor of safety found in the hydraulic loading rates. Organic loadings do appear to have less impact on slowly permeable soils because the resistance of the biomat that forms at the infiltrative surface presents less resistance to infiltration of the wastewater than the soil itself (Bouma, 1975). For a further discussion of SWIS performance under various environmental conditions, see Siegrist and Van Cuyk, 2001b.

### **Width**

Infiltration surface clogging and the resulting loss of infiltrative capacity are less where the infiltration surface is narrow. This appears to occur because reaeration of the soil below a narrow infiltration surface is more rapid. The dominant pathway for oxygen transport to the subsoil appears to be diffusion through the soil surrounding the infiltration surface.

The unsaturated zone below a wide surface quickly becomes anaerobic because the rates of oxygen diffusion are too low to meet the oxygen demands of biota and organics on the infiltration surface. (Otis, 1985; Siegrist et al., 1986). Therefore, trenches perform better than beds. Typical trench widths range from 1 to 4 feet. Narrower trenches are preferred, but soil conditions and construction techniques might limit how narrow a trench can be constructed.

On sloping sites, narrow trenches are a necessity because in keeping the infiltration surface level, the uphill side of the trench bottom might be excavated into a less suitable soil horizon. Wider trench infiltration surfaces have been successful in at grade systems and mounds probably because the engineered fill material and elevation above the natural grade promote better reaeration of the fill.

### **Length**

The trench length is important where downslope linear loadings are critical, ground water quality impacts are a concern, or the potential for ground water mounding exists. In many jurisdictions, trench lengths have been limited to 100 feet. This restriction appeared in early codes written for gravity distribution systems and exists as an artifact with little or no practical basis when pressure distribution is used.

Trench lengths longer than 100 feet might be necessary to minimize ground water impacts and to permit proper wastewater drainage from the site. Long trenches can be used to reduce the linear loadings on a site by spreading the wastewater loading parallel to and farther along the surface contour. With current distribution/dosing technology, materials, and construction methods, trench lengths need be limited only by what is practical or feasible on a given site. Also, use of standard trench lengths, e.g., X feet of trench/BR, is discouraged because it restricts the design options to optimize performance for a given site condition.

### **Height**

The height of the sidewall is determined primarily by the type of porous medium used in the system, the depth of the medium needed to encase the distribution piping, and/or storage requirements for peak flows. Because the sidewall is not included as an active infiltration surface in sizing the infiltration area, the height of the sidewall can be minimized to keep the infiltration surface high in the soil profile. A height of 6 inches is usually sufficient for most porous aggregate applications. Use of a gravelless system requires a separate analysis to determine the height based on whether it is an aggregate-free (empty chamber) design or one that substitutes a lightweight aggregate for washed gravel or crushed stone.

## Geometry, Orientation, and Configuration Considerations for SWI Table

<b>Design type</b>	<b>Design Considerations</b>
<b>Trench Geometry</b>	
Width	Preferably, less than 3 ft. Design width is affected by distribution method, constructability, and available area.
Length	Restricted by available length parallel to site contour, distribution method, and distribution network design
Sidewall height Orientation/configuration	<p>Sidewalls are not considered an active infiltration surface. Minimum height is that needed to encase the distribution piping or to meet peak flow storage requirements.</p> <p>Should be constructed parallel to site contours and/or water table or restrictive layer contours.</p> <p>Should not exceed the site's maximum linear hydraulic loading rate per unit of length. Spacing of multiple, parallel trenches is also limited by the construction method and slow dispersion from the trenches.</p>
<b>Bed</b>	
<b>Geometry</b>	
Width	Should be as narrow as possible. Beds wider than 10 to 15 feet should be avoided.
Length	Restricted by available length parallel to site contour, distribution method, and distribution network design.
Sidewall height Orientation/configuration	<p>Sidewalls are not considered an active infiltration surface. Minimum height is that needed to encase the distribution piping or to meet peak flow storage requirements.</p> <p>Should be constructed parallel to site contours and/or water table or restrictive layer contours. The loading over the total projected width should not exceed the estimated downslope maximum linear hydraulic loading.</p>
<b>Seepage pit</b>	Not recommended because of limited treatment capability.

## Infiltration Surface Orientation

Orientation of the infiltration surface(s) becomes an important consideration on sloping sites, sites with shallow soils over a restrictive horizon or saturated zone, and small or irregularly shaped lots. The long axes of trenches should be aligned parallel to the ground surface contours to reduce linear contour hydraulic loadings and ground water mounding potential. In some cases, ground water or restrictive horizon contours may differ from surface contours because of surface grading or the soil's morphological history. Where this occurs, consideration should be given to aligning the trenches with the contours of the limiting condition rather than those of the surface.

**Characteristics of Typical SWIS Applications Table**

Characteristic	Typical application	Applications to avoid <sup>a</sup>
Type of wastewater	Domestic and commercial (residential, mobile home parks, campgrounds, schools, restaurants, etc.)	Facilities with non-sanitary and/or industrial wastewaters. Check local codes for other possible restrictions
Daily flow	<20 population equivalents unless a management entity exists	>20 population equivalents without a management program. Check local codes for specific or special conditions (e.g., USEPA or state Underground Injection Control Program Class V rule)
Minimum pretreatment	Septic tank, Imhoff tank	Discharge of raw wastewater to SWIS
Lot orientation	Loading along contour(s) must not exceed the allowable contour loading rate	Any site where hydraulic loads from the system will exceed allowable contour loading rates
Landscape position	Ridge lines, hilltops, shoulder/side slopes	Depressions, foot slopes concave slopes, floodplains
Topography	Planar, mildly undulating slopes of 20% grade	Complex slopes of >30%
Soil texture	Sands to clay loams	Very fine sands, heavy clays, expandable clays
Soil structure	Granular, blocky	Platy, prismatic, or massive soils
Drainage	Moderately drained or well drained sites	Extremely well, somewhat poor, or very poorly drained sites
Depth to ground water or bedrock	>5 feet	<2 feet. Check local codes for specific requirements
<sup>a</sup> Avoid when possible Source: Adapted from WEF, 1990		

Extending the trenches perpendicular to the ground water gradient reduces the mass loadings per unit area by creating a "line" source rather than a "point" source along the contour.

However, the designer must recognize that the depth of the trenches and the soil horizon in which the infiltration surface is placed will vary across the system. Any adverse impacts this might have on system performance should be mitigated through design adjustments.

### **Multiple Trenches Configuration**

The spacing of multiple trenches constructed parallel to one another is determined by the soil characteristics and the method of construction. The sidewall-to-sidewall spacing must be sufficient to enable construction without damage to the adjacent trenches.

Only in very tight soils will normally used spacings be inadequate because of high soil wetness and capillary fringe effects, which can limit oxygen transfer. It is important to note that the sum of the hydraulic loadings to one or more trenches or beds per each unit of contour length (when projected downslope) must not exceed the estimated maximum contour loading for the site. Also, the finer (tighter) the soil, the greater the trench spacing should be to provide sufficient oxygen transfer. Quantitative data are lacking, but Camp (1985) reported a lateral impact of more than 2.0 meters in a clay soil.

Given the advantages of lightweight gravelless systems in terms of potentially reduced damage to the site's hydraulic capacity, parallel trenches may physically be placed closer together, but the downslope hydraulic capacity of the site and the natural oxygen diffusion capacity of the soil cannot be exceeded.

### **Wastewater Distribution onto the Infiltration Surface**

The method and pattern of wastewater distribution in a subsurface infiltration system are important design elements. Uniform distribution aids in maintaining unsaturated flow below the infiltration surface, which results in wastewater retention times in the soil that are sufficiently long to effect treatment and promote subsoil reaeration. Uniform distribution design also results in more complete utilization of the infiltration surface.

Gravity flow and dosing are the two most commonly used distribution methods. For each method, various network designs are used. Gravity flow is the most commonly used method because it is simple and inexpensive. This method discharges effluent from the septic tank or other pretreatment tank directly to the infiltration surface as incoming wastewater displaces it from the tank(s). It is characterized by the term "trickle flow" because the effluent is slowly discharged over much of the day.

Typically, tank discharges are too low to flow throughout the distribution network. Thus, distribution is unequal and localized overloading of the infiltration surface occurs with concomitant poor treatment and soil clogging (Bouma, 1975; McGauhey and Winneberger, 1964; Otis, 1985; Robeck et al., 1964).

### **Doses to the Infiltration**

Dosing, on the other hand, accumulates the wastewater effluent in a dose tank from which the water is periodically discharged under pressure in "doses" to the infiltration system by a pump or siphon. The pretreated wastewater is allowed to accumulate in the dose tank and is discharged when a predetermined water level, water volume, or elapsed time is reached. The dose volumes and discharge rates are usually such that much of the distribution network is filled, resulting in more uniform distribution over the infiltration surface.

Dosing outperforms gravity/flow systems because distribution is more uniform. In addition, the periods between doses provide opportunities for the subsoil to drain and reaerate before the next dose (Bouma et al., 1974; Hargett et al., 1982; Otis et al., 1977). However, which method is most appropriate depends on the specific application.

## Distribution Methods and Applications Table

<b>Method</b>	<b>Typical Application</b>
Gravity flow 4-inch perforated pipe Distribution box Serial relief line Drop box	Single or looped trenches at the same elevation; beds. Multiple independent trenches on flat or sloping sites. Multiple serially connected trenches on a sloping site. Multiple independent trenches on a sloping site
<b>Dosed distribution</b>	
4-inch perforated pipe (with or without a distribution box) Pressure manifold Rigid pipe pressure network Dripline pressure network	Single (or multiple) trenches, looped trenches at the same elevation, and beds Multiple independent trenches on sloping sites. Multiple independent trenches at the same elevation (a preferred method for larger SWISs) Multiple independent trenches on flat or sloping sites (a preferred method for larger SWISs)



## Gravity Flow

Gravity flow can be used where there is a sufficient elevation difference between the outlet of the pretreatment tank and the SWIS to allow flow to and through the SWIS by gravity.

Gravity flow systems are simple and inexpensive to construct but are the least efficient method of distribution. Distribution is very uneven over the infiltration surface, resulting in localized overloading (Converse, 1974; McGauhey and Winneberger, 1964; Otis et al., 1978; University of Wisconsin, 1978).

Until a biomat forms on the infiltration surface to slow the rate of infiltration, the wastewater residence time in the soil might be too short to effect good treatment. As the biomat continues to form on the overloaded areas, the soil surface becomes clogged, forcing wastewater effluent to flow through the porous medium of the trench until it reaches an unclogged infiltration surface. This phenomenon, known as "progressive clogging," occurs until the entire infiltration surface is ponded and the sidewalls become the more active infiltration surfaces. Without extended periods of little or no flow to allow the surface to dry, hydraulic failure becomes imminent.

Although inefficient, these systems can work well for seasonal homes with intermittent use or for households with low occupancies. Seasonal use of SWISs allows the infiltration surface to dry and the biomat to oxidize, which rejuvenates the infiltration capacity. Low occupancies result in mass loadings of wastewater constituents that are lower and less likely to exceed the soil's capacity to completely treat the effluent.

### More on Perforated Pipe

Four-inch diameter perforated plastic pipe is the most commonly used distribution piping for gravity flow systems. The piping is generally smooth-walled rigid polyvinyl chloride (PVC), or flexible corrugated polyethylene (PE) or acrylonitrile-butadiene styrene (ABS).

One or two rows of holes or slots spaced 12 inches apart are cut into the pipe wall. Typically, the piping is laid level in gravel with the holes or slots at the bottom (ASTM, undated). One distribution line is used per trench. In bed systems, multiple lines are installed 3 to 6 feet apart.

### Distribution Box

Distribution boxes are used to divide the wastewater effluent flow among multiple distribution lines. They are shallow, flat bottomed, watertight structures with a single inlet and individual outlets provided at the same elevation for each distribution line.

An above-grade cover allows access to the inside of the box. The "d-box" must be laid level on a sound, frost-proof footing to divide the flow evenly among the outlets. Uneven settlement or frost heaving results in unequal flow to the lateral lines because the outlet hole elevations cease to be level. If this occurs, adjustments must be made to re-establish equal division of flow. Several devices can be used.

Adjustable weirs that can level the outlet inverts and maintain the same length of weir per outlet are one option. Other options include designs that allow for leveling of the entire box. The box can also be used to take individual trenches out of service by blocking the outlet to the distribution lateral or raising the outlet weir above the weir elevations for the other outlets. Because of the inevitable movement of d-boxes, their use has been discouraged for many years (USPHS, 1957). However, under a managed care system with regular adjustment, the d-box is acceptable.

### **Serial Relief Line**

Serial relief lines distribute wastewater to a series of trenches constructed on a sloping site. Rather than dividing the flow equally among all trenches as with a distribution box, the uppermost trench is loaded until completely flooded before the next (lower) trench receives effluent. Similarly, that trench is loaded until flooded before discharge occurs to the next trench, and so on. This method of loading is accomplished by installing "relief lines" between successive trenches.

The relief lines are simple overflow lines that connect one trench to the adjacent lower trench. They are solid-wall pipes that connect the crown of the upper trench distribution pipe with the distribution pipe in the lower trench.

Successive relief lines are separated by 5 to 10 feet to avoid short-circuiting. This method of distribution makes full hydraulic use of all bottom and sidewall infiltration surfaces, creates the maximum hydrostatic head over the infiltration surfaces to force the water into the surrounding soil, and eliminates the problem of dividing flows evenly among independent trenches.

However, because continuous ponding of the infiltration surfaces is necessary for the system to function, the trenches suffer hydraulic failure more rapidly and progressively because the infiltration surfaces cannot regenerate their infiltrative capacity.

### **Drop Box**

Drop box distribution systems function similarly to relief line systems except that drop boxes are used in place of the relief lines. Drop boxes are installed for each trench. They are connected in manifolds to trenches above and below. The outlet invert can be placed near the top of each trench to force the trench to fill completely before it discharges to the next trench if a serial distribution mode of operation is desired. Solid wall pipe is used between the boxes.

### **Gravel-less (Graveless) Wastewater Dispersal Systems**

Gravel-less systems have been widely used. They take many forms, including open bottomed chambers, fabric-wrapped pipe, and synthetic materials such as expanded polystyrene foam chips.

Some gravel-less drain field systems use large diameter corrugated plastic tubing covered with permeable nylon filter fabric not surrounded by gravel or rock. The area of fabric in contact with the soil provides the surface for the septic tank effluent to infiltrate the soil. The pipe is a minimum of 10 to 12 inches (25.4 to 30.5 centimeters) in diameter covered with spun bonded nylon filter fabric to distribute water around the pipe.

The pipe is placed in a 12 to 24 inch (30.5 to 61 centimeter) wide trench. These systems can be installed in areas with steep slopes with small equipment and in hand-dug trenches where conventional gravel systems would not be possible.

Reduced sizing of the infiltration surface is often promoted as another advantage of the gravel-less system. This is based primarily on the premise that gravel-less systems do not "mask" the infiltration surface as gravel does where the gravel is in direct contact with the soil.

Proponents of this theory claim that an infiltration surface area reduction of 50 percent is warranted. However, these reductions are not based on scientific evidence though they have been codified in some jurisdictions (Amerson et al., 1991; Anderson et al., 1985; Carlile and Osborne, 1982; Effert and Cashell, 1987).



Although gravel masking might occur in porous medium applications, reducing the infiltration surface area for gravel-less systems increases the BOD mass loading to the available infiltration surface. Many soils might not be able to support the higher organic loading and, as a result, more severe soil clogging and greater penetration of pollutants into the vadose zone and ground water can occur (University of Wisconsin, 1978), negating the benefits of the gravel-less surface.

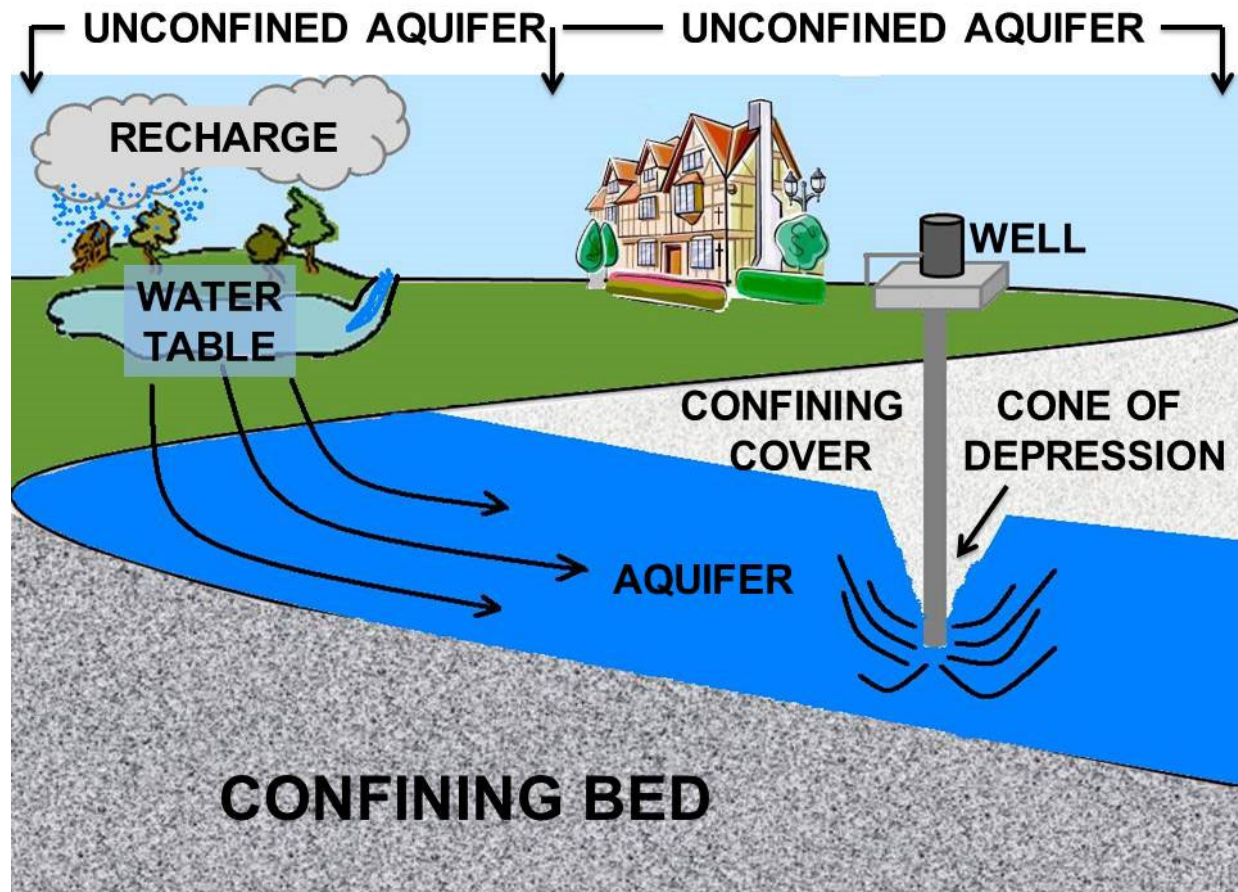

### Vadose Zone

A similar approach must be taken with any contaminant in the pretreatment system effluent that must be removed before it reaches ground water or nearby surface waters. A 50 percent reduction in infiltrative surface area will likely result in less removal of BOD, pathogens, and other contaminants in the vadose zone and increase the presence and concentrations of contaminants in effluent plumes.

The relatively confined travel path of a plume provides fewer adsorption sites for removal of absorbable contaminants (e.g., metals, phosphorus, toxic organics).

Because any potential reductions in infiltrative surface area must be analyzed in a similar comprehensive fashion, the use of gravel-less medium should be treated similarly to potential reductions from increased pretreatment and better distribution and dosing concepts.

Despite the cautions stated above, the overall inherent value of lightweight gravel-less systems should not be ignored, especially in areas where gravel is expensive and at sites that have soils that are susceptible to smearing or other structural damage during construction due to the impacts of heavy machinery on the site.

In all applications where gravel is used (see SWIS Media in the following section), it must be properly graded and washed. Improperly washed gravel can contribute fines and other material that can plug voids in the infiltrative surface and reduce hydraulic capability. Gravel that is embedded into clay or fine soils during placement can have the same effect.

### **Leaching Chambers**

A leaching chamber is a wastewater treatment system that consists of trenches or beds and one or more distribution pipes or open-bottomed plastic chambers. Leaching chambers have two key functions: to disperse the effluent from septic tanks and to distribute this effluent throughout the trenches.

A typical leaching chamber consists of several high-density polyethylene injection-molded arch-shaped chamber segments. A typical chamber has an average inside width of 15 to 40 inches and an overall length of 6 to 8 feet.

The chamber segments are usually 1-foot high, with wide slotted sidewalls. Depending on the drain field size requirements, one or more chambers are typically connected to form an underground drain field network.

Typical leaching chambers are gravel-less systems that have drain field chambers with no bottoms and plastic chamber sidewalls, available in a variety of shapes and sizes. Use of these systems sometimes decreases overall drain field costs and may reduce the number of trees that must be removed from the drain field lot.

## Dosed Flow Distribution

Dosed-flow distribution systems are a significant improvement over gravity-flow distribution systems. The design of dosed-flow systems includes both the distribution network and the dosing equipment.

Dosing achieves better distribution of the wastewater effluent over the infiltration surface than gravity flow systems and provides intervals between doses when no wastewater is applied. As a result, dosed-flow systems reduce the rate of soil clogging, more effectively maintain unsaturated conditions in the subsoil (to effect good treatment through extended residence times and increased reaeration potential), and provide a means to manage wastewater effluent applications to the infiltration system (Hargett et al., 1982). They can be used in any application and should be the method of choice.

Unfortunately, they are commonly perceived to be less desirable because they add a mechanical component to an otherwise "passive" system and add cost because of the dosing equipment. The improved performance of dosed-flow systems over gravity flow systems should outweigh these perceived disadvantages, especially when a management entity is in place.

It must be noted, however, that if dosed infiltration systems are allowed to pond, the advantages of dosing are lost because the bottom infiltration surface is continuously inundated and no longer allowed to rest and reaerate. Therefore, there is no value in using dosed-flow distribution in SWISs designed to operate ponded, such as systems that include sidewall area as an active infiltration surface or those using serial relief lines.

Four-inch perforated pipe networks (with or without d-boxes or pressure manifolds) that receive dosed-flow applications are designed no differently than gravity-flow systems. Many of the advantages of dosing are lost in such networks, however, because the distribution is only slightly better than that of gravity-flow systems (Converse, 1974).

### Pressure Manifold

A pressure manifold consists of a large-diameter pipe tapped with small outlet pipes that discharge to gravity laterals.

A pump pressurizes the manifold, which has a selected diameter to ensure that pressure inside the manifold is the same at each outlet. This method of flow division is more accurate and consistent than a distribution box, but it has the same shortcoming since flow after the manifold is by gravity along each distribution lateral. Its most common application is to divide flow among multiple trenches constructed at different elevations on a sloping site.

**Dosing Methods and Devices Table**  
**Dosing Method    Typical Application**

On-Demand	Dosing occurs when a sufficient volume of wastewater has accumulated in the dose tank to activate the pump switch or siphon. Dosing continues until preselected low water level is reached. Typically, there is no control on the daily volume of wastewater closed.
Timed	Dosing is performed by pumps on a timed cycle, typically at equal intervals and for preset dose volumes so that the daily volume of wastewater dosed does not exceed the system's design flow. Controls can be set so that only full doses occur. Peak flows are stored in the dose tank for dosing during low flow periods. Excessive flows are retained in the tank, and, if they persist, a high water alarm alerts the owner of the need for remedial action. This approach prevents unwanted and detrimental discharges to the SWIS.
<b>Dosing device</b>	
Pump	Pressure distribution networks are set at elevations that are typically higher than the dose tank. Multiple infiltration areas can be dosed from the same tank using multiple, alternating pumps or automatic valves.
Siphon	On-demand dosing of gravity of pressure distribution networks is used where the elevation between the siphon invert and the distribution pipe orifices is sufficient for the siphon to operate. Siphons cannot be used for timed dosing. Two siphons in the same dose tank can be used to alternate automatically between two infiltration areas.

## Pressure Manifold for Different Applications

**The Pressure Manifold Sizing Table** (next page) can be used to size a pressure manifold for different applications. This table was developed by Berkowitz (1985) to size the manifold diameter based on the spacing between pressure lateral taps, the lateral tap diameter, and the number of lateral taps.

The hydraulic computations made to develop the table set a maximum flow differential between laterals of 5 percent. The dosing rate is determined by calculating the flow in a single lateral tap assuming 1 to 4 feet of head at the manifold outlets and multiplying the result by the number of lateral taps. The Hazen-Williams equation for pipe flow can be used to make this calculation.

### Rigid Pipe Pressure Distribution Networks

Rigid pipe pressure distribution networks are used to provide relatively uniform distribution of wastewater effluent over the entire infiltration surface simultaneously during each dose. They are well suited for all dosed systems. Because they deliver the same volume of wastewater effluent per linear length of lateral, they can be used to dose multiple trenches of unequal length. Although rigid pipe pressure networks can be designed to deliver equal volumes to trenches at different elevations (Mote, 1984; Mote et al., 1981; Otis, 1982), these situations should be avoided.

Uniform distribution is achieved only when the network is fully pressurized. During filling and draining of the network, the distribution lateral at the lowest elevation receives more water. This disparity increases with increasing dosing frequency. As an alternative on sloping sites, the SWIS could be divided into multiple cells, with the laterals in each cell at the same elevation. If this is not possible, other distribution designs should be considered.

A simplified method of network design has been developed (Otis, 1982). Lateral and manifold sizing is determined using a series of graphs and tables after the designer has selected the desired orifice size and spacing and the distal pressure in the network (typically 1 to 2 feet of head). These graphs and tables were derived by calculating the change in flow and pressure at each orifice between the distal and proximal ends of the network. The method is meant to result in discharge rates from the first and last orifices that differ by no more than 10 percent in any lateral and 15 percent across the entire network.

However, subsequent testing of field installations indicated that the design model overestimates the maximum lateral length by as much as 25 percent (Converse and Otis, 1982). Therefore, if the graphs and tables are used, the maximum lateral length for any given orifice size and spacing should not exceed 80 percent of the maximum design length suggested by the lateral sizing graphs. In lieu of using the graphs and tables, a spreadsheet could be written using the equations presented and adjusting the orifice discharge coefficient.

To achieve uniform distribution, the density of orifices over the infiltration surface should be as high as possible. However, the greater the number of orifices used, the larger the pump must be to provide the necessary dosing rate.

To reduce the dosing rate, the orifice size can be reduced, but the smaller the orifice diameter, the greater the risk of orifice clogging. Orifice diameters as small as 1/8 inch have been used successfully with septic tank effluent when an effluent screen is used at the septic tank outlet.

**Pressure Manifold Sizing Table**

Tap spacing (feet)	Manifold size (inches)	Single-sided manifold						Double-sided manifold					
		Lateral tap diameter (inches)						Lateral tap diameter (inches)					
		0.5	0.7	1.0	1.2	1.5	2.0	0.5	0.7	1.0	1.2	1.5	2.0
		Maximum number of lateral taps						Maximum number of lateral taps					
0.5	2	4	2					2					
	3	9	5	3	2			4	2				
	4	16	9	5	3	2		7	4	2			
	6	>	21	12	7	5	3		10	6	3	2	
	8		38	22	12	9	5		17	10	6	4	2
3.0	2	8	2					2					
	3	14	12	3	2			6	2				
	4	21	18	6	3	2			5	3			
	6	38	30	26	8	5	3	>	19	7	3	2	
6.0	2	5	4					4					
	3	9	7	6	2			7	3	2			
	4	14	11	9	4	2			9	3			
	6	27	20	17	14	7	3		15	13	4	3	

Source: Adapted from Berkowitz, 1985.

Orifice spacings typically are 1.5 to 4 feet, but the greater the spacing, the less uniform the distribution because each orifice represents a point load. It is up to the designer to achieve the optimum balance between orifice density and pump size. The dose volume is determined by the desired frequency of dosing and the size of the network. Often, the size of the network will control design.

During filling and draining of the network at the start and end of each dose, the distribution is less uniform. The first holes in the network discharge more during initial pressurization of the network, and the holes at the lowest elevation discharge more as the network drains after each dose.

To minimize the relative difference in discharge volumes, the dose volume should be greater than five times the volume of the distribution network (Otis, 1982). A pump or siphon can be used to pressurize the network.

## Dripline Pressure Network

Drip distribution, which was derived from drip irrigation technology, was recently introduced as a method of wastewater distribution.

It is a method of pressure distribution capable of delivering small, precise volumes of wastewater effluent to the infiltration surface. It is the most efficient of the distribution methods and is well suited for all types of SWIS applications. A dripline pressure network consists of several components:

- ✓ Dose tank
- ✓ Pump
- ✓ Prefilter
- ✓ Supply manifold
- ✓ Pressure regulator (when turbulent, flow emitters are used)
- ✓ Dripline
- ✓ Emitters
- ✓ Vacuum release valve
- ✓ Return manifold
- ✓ Flush valve
- ✓ Controller

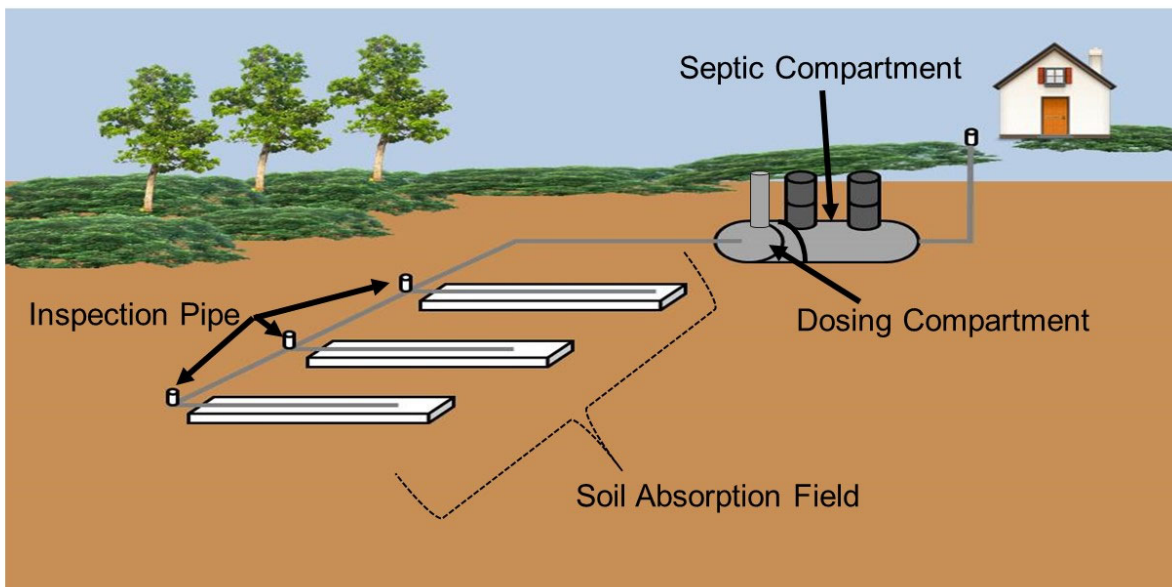

## PRESSURE AND DRIP DISPERSAL SYSTEM

The pump draws wastewater effluent from the dose tank, preferably on a timed cycle, to dose the distribution system. Before entering the network, the effluent must be prefiltered through mechanical or granular medium filters.

The former are used primarily for large SWIS systems. The backflush water generated from a self-cleaning filter should be returned to the headworks of the treatment system. The effluent enters the supply manifold that feeds each dripline.

If turbulent flow emitters are used, the filtered wastewater must first pass through a pressure regulator to control the maximum pressure in the dripline. Usually, the dripline is installed in shallow, narrow trenches 1 to 2 feet apart and only as wide as necessary to insert the dripline using a trenching machine or vibratory plow.

The trench is backfilled without any porous medium so that the emitter orifices are in direct contact with the soil. The distal ends of each dripline are connected to a return manifold. The return manifold is used to regularly flush the dripline. To flush, a valve on the manifold is opened and the effluent is flushed through the driplines and returned to the treatment system headworks.

Because of the unique construction of drip distribution systems, they cause less site disruption during installation, are adaptable to irregularly shaped lots or other difficult site constraints, and use more of the soil mantle for treatment because of the shallow depth of placement.

In addition, because the installed cost per linear foot of dripline is usually less than the cost of conventional trench construction, dripline can be added to decrease mass loadings to the infiltration surface at lower costs than other distribution methods.

Because of the equipment required, however, drip distribution tends to be more costly to construct and requires regular operation and maintenance by knowledgeable individuals. Therefore, it should be considered for use only where operation and maintenance support is ensured.

The dripline is normally a ½ inch-diameter flexible polyethylene tube with emitters attached to the inside wall spaced 1 to 2 feet apart along its length. Because the emitter passageways are small, friction losses are large and the rate of discharge is low (typically from 0.5 to nearly 2 gallons per hour).

Two types of emitters are used. One is a "turbulent-flow" emitter, which has a very long labyrinth. Flow through the labyrinth reduces the discharge pressure nearly to atmospheric rates. With increasing in-line pressure, more wastewater can be forced through the labyrinth. Thus, the discharges from turbulent flow emitters are greater at higher pressures. To more accurately control the rate of discharge, a pressure regulator is installed in the supply manifold upstream of the dripline.

Inlet pressures from a minimum of 10 psi to a maximum of 45 psi are recommended. The second emitter type is the pressure-compensating emitter. This emitter discharges at nearly a constant rate over a wide range of in-line pressures.



## Placement and Layout of Drip Systems Sub-Section

When drip distribution was introduced, the approach to sizing SWISs using this distribution method was substantially different from that for SWISs using other distribution methods. Manufacturer? Recommended hydraulic loading rates were expressed in terms of gallons per day per square foot of drip distribution footprint area.

Typically, the recommended rates were based on 2-foot emitter and dripline spacing. Therefore, each emitter would serve 4 square feet of footprint area. Because the dripline is commonly plowed into the soil without surrounding it with porous medium, the soil around the dripline becomes the actual infiltration surface.

The amount of infiltration surface provided is approximately 2/3 to 1 square foot per 5 linear feet of dripline. As a result, the wastewater-loading rate is considerably greater than the hydraulic loadings recommended for traditional SWISs. Experience has shown however, that the hydraulic loading on this surface can be as much as seven times higher than that of traditional SWIS designs (Ayles Associates, 1994). This is probably due to the very narrow geometry, higher levels of pretreatment, shallow placement, and intermittent loadings of the trenches, all of which help to enhance reaeration of the infiltration surface.

### Hydraulic Loadings for Drip Distribution

The designer must be aware of the differences between the recommended hydraulic loadings for drip distribution and those customarily used for traditional SWISs. The recommended drip distribution loadings are a function of the soil, dripline spacing, and applied effluent quality. It is necessary to express the hydraulic loading in terms of the footprint area because the individual dripline trenches are not isolated infiltration surfaces.

If the emitter and/or dripline spacing is reduced, the wetting fronts emanating from each emitter could overlap and significantly reduce hydraulic performance. Therefore, reducing the emitter and/or dripline spacing should not reduce the overall required system footprint. Reducing the spacing might be beneficial for irrigating small areas of turf grass, but the maximum daily emitter discharge must be reduced proportionately by adding more dripline to maintain the same footprint size. Using higher hydraulic loading rates must be carefully considered in light of secondary boundary loadings, which could result in excessive ground water mounding.

Further, the instantaneous hydraulic loading during a dose must be controlled because storage is not provided in the dripline trench. If the dose volume is too high, the wastewater can erupt at the ground surface. Layout of the drip distribution network must be considered carefully. Two important consequences of the network layout are the impacts on dose pump sizing necessary to achieve adequate flushing flows and the extent of localized overloading due to internal dripline drainage.

### Flushing Flow Rates

Flushing flow rates are a function of the number of manifold/dripline connections: More connections create a need for greater flushing flows, which require a larger pump. To minimize the flushing flow rate, the length of each dripline should be made as long as possible in accordance with the manufacturer's recommendations. To fit the landscape, the dripline can be looped between the supply and return manifolds. Consideration should also be given to dividing the network into more than one cell to reduce the number of connections in an individual network.

A computer program has been developed to evaluate and optimize the hydraulic design for adequate flushing flows of dripline networks that use pressure-compensating emitters (Berkowitz and Harman, 1994).

### Internal Drainage

Internal drainage that occurs following each dose or when the soils around the dripline are saturated can cause significant hydraulic overloading to lower portions of the SWIS.

Following a dose cycle, the dripline drains through the emitters. On sloping sites, the upper driplines drain to the lower driplines, where hydraulic overloading can occur. Any free water around the dripline can enter through an emitter and drain to the lowest elevation. Each of these events needs to be avoided as much as possible through design.

The designer can minimize internal drainage problems by isolating the driplines from each other in a cell, by aligning the supply and return manifolds with the site's contours. A further safeguard is to limit the number of doses per day while keeping the instantaneous hydraulic loadings to a minimum so the dripline trench is not flooded following a dose. This trade-off is best addressed by determining the maximum hydraulic loading and adjusting the number of doses to fit this dosing volume.

### Dripline Freezes

Freezing of dripline networks has occurred in severe winter climates. Limited experience indicates that shallow burial depths together with a lack of uncompacted snow cover or other insulating materials might lead to freezing. In severe winter climates, the burial depth of dripline should be increased appropriately and a good turf grass established over the network.

Mulching the area the winter after construction or every winter should be considered. In addition, it is good practice to install the vacuum release valves below grade and insulate the air space around them. Although experience with drip distribution in cold climates is limited, these safeguards should provide adequate protection.

### Dosing Methods

Two methods of dosing have been used. With on-demand dosing, the wastewater effluent rises to a preset level in the dose tank and the pump or siphon is activated by a float switch or other mechanism to initiate discharge. During peak-flow periods, dosing is frequent with little time between doses for the infiltration system to drain and the subsoil to re-aerate. During lowflow periods, dosing intervals are long, which can be beneficial in controlling biomat development but is inefficient in using the hydraulic capacity of the system.

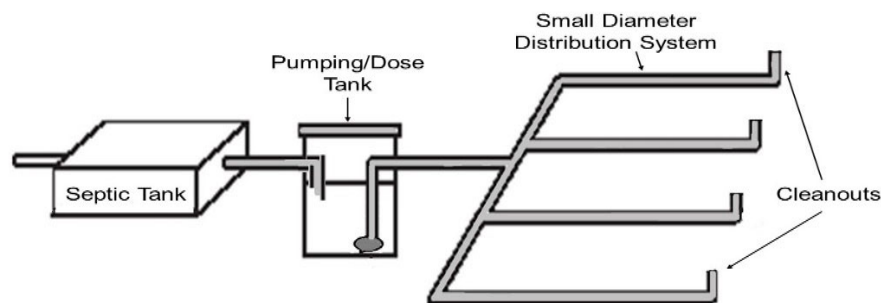

**DOSE FLOW SYSTEM DESIGN**

## **SWIS Media**

A porous medium is placed below and around SWIS distribution piping to expand the infiltration surface area of the excavation exposed to the applied wastewater. This approach is similar in most SWIS designs, except when drip distribution or aggregate-free designs are used. In addition, the medium also supports the excavation sidewalls, provides storage of peak wastewater flows, minimizes erosion of the infiltration surface by dissipating the energy of the influent flow, and provides some protection for the piping from freezing and root penetration.

Traditionally, washed gravel or crushed rock, typically ranging from ¾ to 2½ inches in diameter, has been used as the porous medium. The rock should be durable, resistant to slaking and dissolution, and free of fine particles.

A hardness of at least 3 on the Moh's scale of hardness is suggested. Rock that can scratch a copper penny without leaving any residual meets this criterion. It is important that the medium be washed to remove fine particles. Fines from insufficiently washed rock have been shown to result in significant reductions in infiltration rates (Amerson et al., 1991).

In all applications where gravel is used, it must be properly graded and washed. Improperly washed gravel can contribute fines and other material that can plug voids in the infiltrative surface and reduce hydraulic capability. Gravel that is embedded into clay or fine soils during placement can have the same effect.

In addition to natural aggregates, gravelless systems have been widely used as alternative SWIS medium. These systems take many forms, including open-bottomed chambers, fabric-wrapped pipe, and synthetic materials such as expanded polystyrene foam chips, as described in the preceding section.

Systems that provide an open chamber are sometimes referred to as "aggregate-free" systems, to distinguish them from others that substitute lightweight medium for gravel or stone.

These systems provide a suitable substitute in locales where gravel is not available or affordable. Some systems (polyethylene chambers and lightweight aggregate systems) can also offer substantial advantages in terms of reduced site disruption over the traditional gravel because their lightweight makes them easy to handle without the use of heavy equipment. These advantages reduce labor costs, limit damage to the property by machinery, and allow construction on difficult sites where conventional medium could not reasonably be used.

## **Construction Considerations**

Construction practices are critical to the performance of SWISs. Satisfactory SWIS performance depends on maintaining soil porosity. Construction activities can significantly reduce the porosity and cause SWISs to hydraulically fail soon after being brought into service.

Good construction practices should carefully consider site protection before and during construction, site preparation, and construction equipment selection and use.

Good construction practices for at-grade and mound systems can be found elsewhere (Converse and Tyler, 2000; Converse et al., 1990). Many of them, however, are similar to those described in the following subsections.

### **Site Protection**

Construction of the onsite wastewater system is often only one of many construction activities that occur on a property. If not protected against intrusion, the site designated for the onsite system can be damaged by other, unrelated construction activities. Therefore, the site should be staked and roped off before any construction activities begin to make others aware of the site and to keep traffic and materials stockpiles off the site.

The designer should anticipate what activities will be necessary during construction and designate acceptable areas for them to occur. Site access points and areas for traffic lanes, material stockpiling, and equipment parking should be designated on the drawings for the contractor.

### **Site Preparation**

Site preparation activities include clearing and surface preparation for filling. Before these activities are begun, the soil moisture should be determined. In non-granular soils, compaction will occur if the soil is near its plastic limit. This can be tested by removing a sample of soil and rolling it between the palms of the hands. If the soil fails to form a "rope" the soil is sufficiently dry to proceed. However, constant care should be taken to avoid soil disturbance as much as possible.

### **Clearing**

Clearing should be limited to mowing and raking because the surface should be only minimally disturbed. If trees must be removed, they should be cut at the base of the trunk and removed without heavy machinery. If it is necessary to remove the stumps, they should be ground out. Grubbing of the site (mechanically raking away roots) should be avoided. If the site is to be filled, the surface should be moldboard or chisel-plowed parallel to the contour (usually to a depth of 7 to 10 inches) when the soil is sufficiently dry to ensure maximum vertical permeability.

The organic layer should not be removed. Scarifying the surface with the teeth of a backhoe bucket is not sufficient.

### **Excavation**

Excavation activities can cause significant reductions in soil porosity and permeability (Tyler et al., 1985).

Compaction and smearing of the soil infiltrative surface occur from equipment traffic and vibration, scraping actions of the equipment, and placement of the SWIS medium on the infiltration surface. Lightweight backhoes are most commonly used. Front-end loaders and blades should not be used because of their scraping action.

All efforts should be made to avoid any disturbance to the exposed infiltration surface. Equipment should be kept off the infiltration field. Before the SWIS medium is installed, any smeared areas should be scarified and the surface gently raked. If gravel or crushed rock is to be used for SWIS medium, the rock should be placed in the trench by using the backhoe bucket rather than dumping it directly from the truck.

If damage occurs, it might be possible to restore the area, but only by removing the compacted layer. It might be necessary to remove as much as 4 inches of soil to regain the natural soil porosity and permeability (Tyler et al., 1985).

## Onsite References and Credits

U.S. Environmental Protection Agency. Feb. 2002. Onsite Wastewater Treatment Systems Manual. EPA-625-R-00-008.

Ohio State University. Soil and Site Evaluation for Onsite Wastewater Treatment. Bulletin 905. EPA-625-R-00-008.

Paul Trotta, P.E., Ph.D., Justin Ramsey, P.E., Chad Cooper, Northern Arizona University

David Lindbo, Ph.D. NC State University. September 2004. University Curriculum Development for Decentralized Wastewater Management - Site Evaluation Module Text.

<http://onsite.tennessee.edu/University%20Site%20and%20Soil%20Evaluation.pdf>

University of Nebraska –Lincoln Extension. Sept. 2006. Residential Onsite Wastewater Treatment: Site Evaluation.

S.A. Holden, M.H. Stolt, G.W. Loomis, and A.J. Gold. Seasonal Variation in Nitrogen Leaching from Shallow-Narrow Drainfields. Abstract retrieved from the World Wide Web January 3, 2007. <http://asae.frymulti.com/abstract.asp?aid=15802&t=1>

U.S. Environmental Protection Agency. Sept. 1999. The Class V Underground Injection Control Study. EPA/816-R-99-014e. Volume 5, Large-Capacity Septic Systems. Retrieved from the World Wide Web January 3, 2007.

[http://www.epa.gov/ogwdw/uic/class5/classv\\_study.html](http://www.epa.gov/ogwdw/uic/class5/classv_study.html)

Poeter, Thyne, McCray, and Siegrist. Jan. 2005. Colorado School of Mines Golden, Colorado Guidance for Evaluation of Potential Groundwater Mounding Associated with Cluster and High-Density Wastewater Soil Absorption Systems.

[http://www.ndwrcdp.org/userfiles/WUHT0245\\_Electronic.pdf#search=%22Guidance%20for%20Evaluation%20of%20Potential%20Groundwater%20Mounding%20Associated%20with%20Cluster%20and%20HighDensity%20](http://www.ndwrcdp.org/userfiles/WUHT0245_Electronic.pdf#search=%22Guidance%20for%20Evaluation%20of%20Potential%20Groundwater%20Mounding%20Associated%20with%20Cluster%20and%20HighDensity%20)

[Wastewater%20Soil%20Absorption%20Systems%20%22](http://www.ndwrcdp.org/userfiles/WUHT0245_Electronic.pdf#search=%22Guidance%20for%20Evaluation%20of%20Potential%20Groundwater%20Mounding%20Associated%20with%20Cluster%20and%20HighDensity%20)

Wallace and Grubbs in Proceedings of 13th Annual NOWRA Conference. July 2003. Hydrogeological Evaluations for Larger Cluster and High Density Wastewater Soil Absorption Systems. Retrieved from the World Wide Web January 3, 2007. [http://www.ndwrcdp.org/userfiles/CSM-HYDRO\\_1\\_PROG\\_SUMM\\_1ST\\_Q\\_03.pdf](http://www.ndwrcdp.org/userfiles/CSM-HYDRO_1_PROG_SUMM_1ST_Q_03.pdf)

Tyler, EJ, 2001. Hydraulic Wastewater Loading Rates to Soil.

Anderson, J. and D. Gustafson, University of Minnesota Extension Service, 1998. Residential Cluster Development: Alternative Wastewater Treatment Systems.

<http://www.extension.umn.edu/distribution/naturalresources/components/7059-02.html>

American Society for Testing and Materials, 1996. Standard Practice for Subsurface Site Characterization of Test Pits. ASTM Practice D5921-96, Not available online. To purchase see <http://www.astm.org/cgi-bin/SoftCart.exe/>

DATABASE.CART/REDLINE\_PAGES/D5921.htm?E+mystore E-Handbook for Managing Individual and Clustered (Decentralized) Wastewater Treatment Systems 11

**Credits:**

PIPELINE, a quarterly publication of the National Small Flows Clearinghouse, for providing information used in this guide.

Onsite Sewage Treatment Program, University of Minnesota. 2011. Manual for Septic System Professionals in Minnesota, 2nd Ed. St. Paul, MN.

# Post Quiz

## Construction Phases

### Preparation Phase

1. Conduct a pre-construction conference at the site to \_\_\_\_\_, verify setbacks and other site conditions, check surface elevations, and identify potential problems or safety concerns.

### Project Execution

2. Excavate areas for conveyance piping, the tank(s), secondary treatment units, and infiltration or soil dispersal components according to designated depths and \_\_\_\_\_.

### Percolation Tests

3. Maryland and a number of other states also require the use of percolation tests and \_\_\_\_\_ for repairs to existing septic systems that are malfunctioning.

### Fixed Film and Suspended Growth Advanced Treatment Systems

4. \_\_\_\_\_ may also need to be considered when planning large wastewater treatment systems or clustered facilities.

### Septic Tank Construction Considerations

5. Important construction considerations include tank location, bedding and backfilling, watertightness, and \_\_\_\_\_, especially with non-concrete tanks.

### Construction Materials

6. Septic tanks smaller than \_\_\_\_\_ gallons are typically pre-manufactured; larger tanks are constructed in place.

### Watertightness

7. Leaks, whether exfiltrating or infiltrating, are serious. \_\_\_\_\_ of clear water to the tank from the building storm sewer or ground water adds to the hydraulic load of the system and can upset subsequent treatment processes.

### Location

8. The tank should be located where it can be accessed easily for septage removal and sited away from \_\_\_\_\_ where water can collect. Local codes must be consulted regarding minimum horizontal setback distances from buildings, property boundaries, wells, water lines, and the like.

### **Bedding and Backfilling**

9. The tank should rest on\_\_\_\_\_. It is good practice to provide a level, granular base for the tank. The underlying soils must be capable of bearing the weight of the tank and its contents.

### **Joint Watertightness**

10. The joints should be clean and dry before applying the joint sealer. Only \_\_\_\_\_joint sealers should be used.

### **Separation Distance from a Limiting Condition**

11. Placement of the infiltration surface in the soil profile is determined by \_\_\_\_\_.

12. Most current onsite wastewater system codes require minimum separation distances of at least \_\_\_\_\_ inches from the seasonally high water table or saturated zone irrespective of soil characteristics.

13. Generally, \_\_\_\_\_ foot separation distances have proven to be adequate in removing most fecal coliforms in septic tank effluent.

14. A few studies have shown that separation distances of \_\_\_\_\_ inches are sufficient to achieve good fecal coliform removal if the wastewater receives additional pretreatment prior to soil application.

### **Answers**

1. Identify site component locations, 2. Required pipe slopes, 3. Site evaluations, 4. Several additional site evaluation factors, 5. Flotation prevention, 6. 6,000, 7. Infiltration, 8. Drainage swales or depressions, 9. A uniform bearing surface, 10. High-quality, 11. Treatment and hydraulic performance requirements, 12. 18, 13. 2 to 4, 14. 12 to 18



## Chapter 4- WASTEWATER COLLECTION SECTION

**Section Focus:** You will learn the basics of the wastewater collection. At the end of this section, you the student will be able to describe the basics of the gravity collection system and its effect on onsite or septic systems. There is a post quiz at the end of this section to review your comprehension and a final examination in the Assignment for your contact hours.

**Scope/Background:** As an Onsite Operator, you will need knowledge of many different concerns of the collections system in order to properly identify problem. Master's level knowledge of the collection system is essential for all onsite operators.



### Collection System and its Purpose

Every house, restaurant, business, and industry produces waste. Wastewater collection protects public health and the environment by removing this infectious waste and recycling the water. A network of interconnected pipes accepts the flow from each building's sewer connection and delivers it to the treatment facilities. In addition to what homes and businesses flush down the drain, the system also collects excess groundwater, infiltration liquids, and inflow water. Wastewater collection is therefore a comprehensive liquid waste removal system.

The fluid waste distributed through this system is about 98% water. The waste floats on, is carried along by, and goes into suspension or solution in water. Possible waste includes anything that can be flushed down the drain--human excretion, body fluids, paper products, soaps and detergents, foods, fats, oil, grease, paints, chemicals, hazardous materials, solvents, disposable and flushable items; the list is almost infinite. This mixture of water and wastes is called "*wastewater*." In the past, it was known as "*sewage*," but this term is now falling out of favor because it refers specifically to domestic sanitary wastewater, like toilet flushing, which represents only a portion of the entire fluid waste content.

"*Wastewater*" is a more accurate description and has become the standard term for this fluid waste because it encompasses the total slurry of wastes in water that is gathered from homes and businesses.

## Collection System Defined

A system composed of gravity pipes, manholes, tanks, lift stations, control structures, and force mains that gather used water from residential and nonresidential customers and convey the flow to the wastewater treatment plant.

Wastewater systems collect and dispose of household wastewater generated from toilet use, bathing, laundry, and kitchen and cleaning activities.

Any structure with running water, such as a house or office, must be connected to one of the following wastewater disposal systems:

- **Centralized** systems are *public sewer systems* that serve established towns and cities and transport wastewater to a central location for treatment.
- **Decentralized** systems do not connect to a public sewer system. Wastewater may be treated on site or may be discharged to a private treatment plant.

## Centralized Systems

Large-scale public sewer systems (municipal wastewater treatment plants) are centralized systems. These systems generally serve established cities and towns and may provide treatment and disposal services for neighboring sewer districts. Where appropriate, centralized systems are preferred to decentralized systems, as one centralized system can take the place of several decentralized systems. Centralized systems are more economical, allow for greater control, require fewer people, and produce only one discharge to monitor instead of several. However, decentralized systems can be useful, and this option should be evaluated on a case-by-case basis.

## Decentralized Systems

Homes and other buildings that are not served by public sewer systems depend on decentralized septic systems to treat and dispose of wastewater. Most decentralized systems are on-site systems (wastewater is treated underground near where it is generated).

On-site systems are the most common wastewater treatment system used in rural areas. These systems can be a single septic system and drainfield serving one residence or a large soil absorption system serving an entire subdivision. Wastewater in decentralized systems can also be treated by a small, private wastewater treatment plant. These plants can have similar treatment processes and equipment as centralized systems but on a smaller scale.

## Sewer Main

In a centralized wastewater treatment system, the sewer to which sewer connections are made from individual residences.

## Trunk Lines

Sewer pipes measuring more than 12 inches in diameter and having a capacity of 1 to 10 million gallons per day. Trunk lines connect smaller sewer pipes, or collectors, to the largest transport pipes or interceptors.

## Collectors

Small sewer pipes measuring twelve inches or less in diameter.

## Gravity Sewage Collection System

Publicly owned treatment works (POTWs) collect wastewater from homes, commercial buildings, and industrial facilities and transport it via a series of pipes, known as a collection system, to the treatment plant.

Collection systems may flow entirely by gravity, or may include lift stations that pump the wastewater via a force main to a higher elevation where the wastewater can then continue on via gravity. Ultimately, the collection system delivers this sewage to the treatment plant facility. Here, the POTW removes harmful organisms and other contaminants from the sewage so it can be discharged safely into the receiving stream.



New sewer manhole with sewer mains before final burial.

Without treatment, sewage creates bad odors, contaminates water supplies, and spreads disease. Today, more than 16,000 sewage treatment plants exist in the U.S. treating more than 32 billion gallons per day of wastewater.



Modern sewer vector or Camel. It is wise to make friends with the collection crews. The collection crews can greatly assist you in your enforcement efforts and can tell you lots of information, only if you develop a relationship with them.

## Combined Sewer Overflows (CSOs)

Combined sewer systems are designed to collect both sanitary wastewater and storm water runoff. During dry weather, combined sewers carry sanitary waste to a POTW. During wet weather, the combined sanitary waste and storm water can overflow and discharge untreated wastewater directly to a surface water through a combined sewer overflow (CSO).

In 1994, the EPA published a CSO Control Policy (59 FR 18688). CSOs are regulated as point sources, and require NPDES permits.

The CSO Control Policy includes Nine Minimum Controls (NMC) for CSO management, which are requirements for any CSO NPDES Permit:

- ✓ Proper operation and regular maintenance programs for the sewer system and the CSOs;
- ✓ Maximum use of the collection system for storage;
- ✓ Review and modification of pretreatment requirements to ensure that CSO impacts are minimized;
- ✓ Maximization of flow to the POTW for treatment;
- ✓ Prohibition of CSOs during dry weather;
- ✓ Control of solid and floatable materials in CSOs;
- ✓ Establishment of pollution prevention programs;
- ✓ Public notification to ensure that the public receives adequate notification of CSO occurrences and CSO impacts;
- ✓ Monitoring to effectively characterize CSO impacts and the efficacy of CSO controls.

Development of a Long Term Control Plan (LTCP) is also required for management of CSOs. For more information, visit the EPA Wet Weather information page, which includes a graphic representation of Urban Wet Weather Flows.



A Vactor clearing a Manhole.

## Onsite - Collection System Operators' Purpose

Collection system operators are charged with protecting public health and the environment, and therefore must have documented proof of their certifications in the respective wastewater management systems. These professionals ensure that the system pipes remain clear and open. They eliminate obstructions and are constantly striving to improve flow characteristics. They keep the wastewater moving underground, unseen and unheard. Because this wastewater collection system and the professionals who maintain it operate at such a high level of efficiency, problems are very infrequent. So much so that the public often takes the wastewater collection system for granted. In truth, these operators must work hard to keep it functioning properly.

Centralized sewer systems are generally broken out into three different categories: sanitary sewers, storm sewers, and combined sewers. Sanitary sewers carry wastewater or sewage from homes and businesses to treatment plants. Underground sanitary sewer pipes can clog or break, causing unintentional "overflows" of raw sewage that flood basements and streets. Storm sewers are designed to quickly get rainwater off the streets during rain events.

Chemical, trash and debris from lawns, parking lots, and streets are washed by the rain into the storm sewer drains. Most storm sewers do not connect with a treatment plant, but instead drain directly into nearby rivers, lakes, or oceans. Combined sewers carry both wastewater and storm water in the same pipe. Most of the time, combined sewers transport the wastewater and storm water to a treatment plant.

However, when there is too much rain, combined sewer systems cannot handle the extra volume and designed "overflows" of raw sewage into streams and rivers occur. The great majority of sewer systems have separated, not combined, sanitary and storm water pipes.

Leaking, overflowing, and insufficient wastewater collection systems can release untreated wastewater into receiving waters. Outdated pump stations, undersized to carry sewage from newly developed subdivisions or commercial areas, can also create a potential overflow hazard, adversely affecting human health and degrading the water quality of receiving waters. The maintenance of the sewer system is therefore a continuous, never-ending cycle.

As sections of the system age, problems such as corroded concrete pipe, cracked tile, lost joint integrity, grease, and heavy root intrusion must be constantly monitored and repaired. Technology has improved collection system maintenance with such tools as television camera assisted line inspection equipment, jet-cleaning trucks, and improvements in pump design. Because of the increasing complexity of wastewater collection systems, collection system maintenance is evolving into a highly skilled trade.

According to a recent Clean Water Needs Survey conducted by the USEPA, the U.S. will have to invest more than \$10 billion to upgrade existing wastewater collection systems, over \$20 billion for new sewer construction, and nearly \$44 billion to improve sewer overflows, to effectively serve the projected population. As the infrastructure in the United States and other parts of the world ages, increasing importance is being placed on rehabilitating wastewater collection systems. Cracks, settling, tree root intrusion, and other disturbances that develop over time deteriorate pipelines and other conveyance structures that comprise wastewater collection systems, including stormwater, sanitary, and combined sewers.

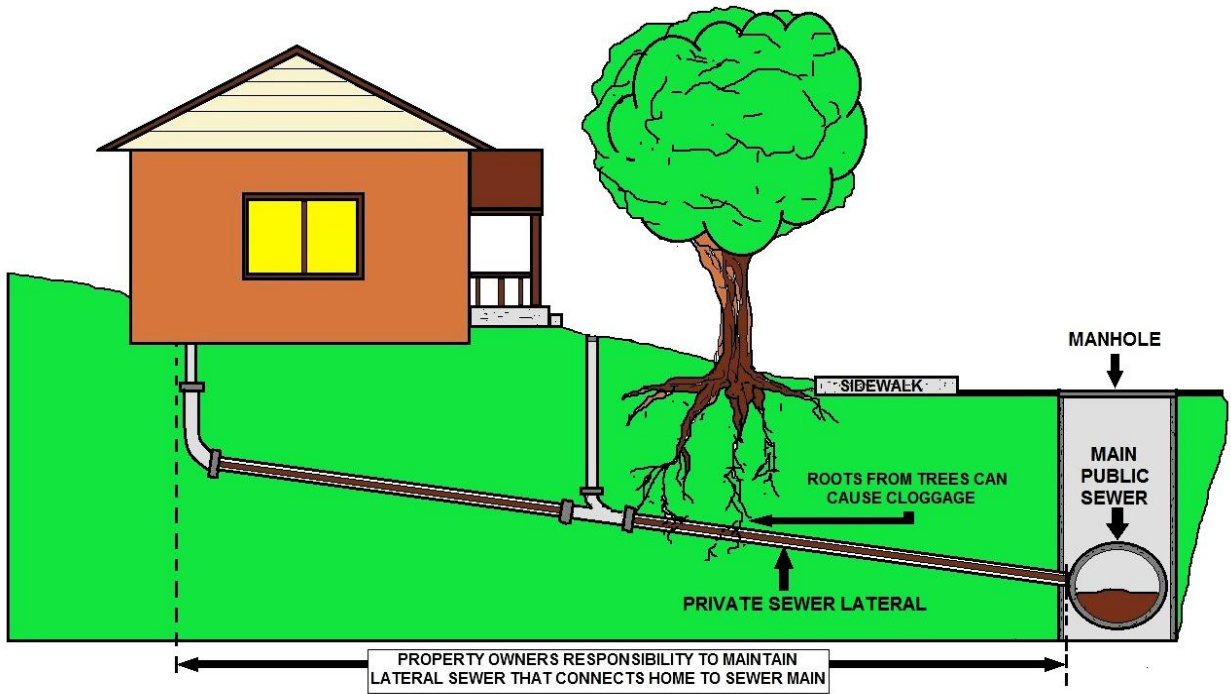

**DIAGRAM OF SEWER LATERAL**

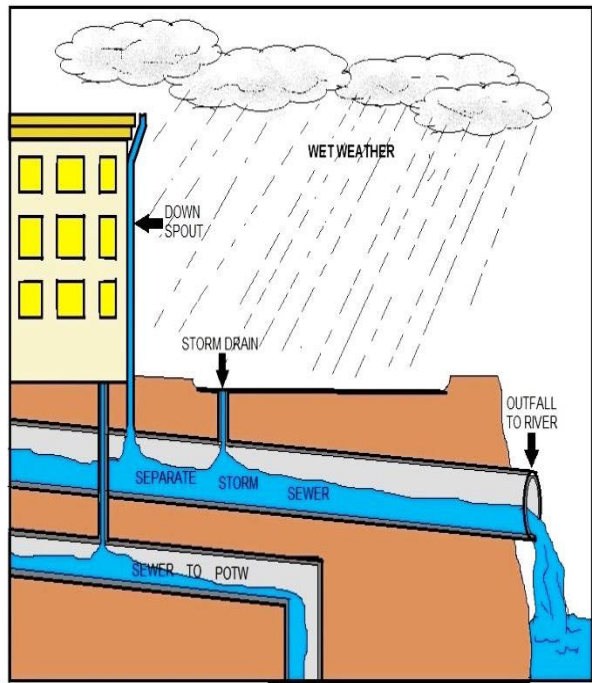
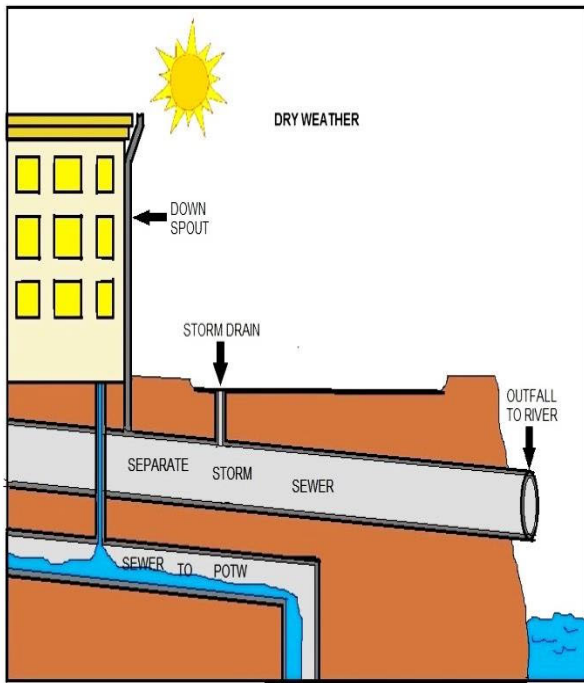



## Collections Daily Operations

The Sewer Cleaning Truck above is 38 feet long and 9 feet wide. The attached tank has a capacity of 1500 gallons and can hold 10 cubic yards of debris. The truck is equipped with a high pressure cleaning head that can move 800 feet down a sanitary line at 2500 PSI.

Out of sight, out of mind—that's your sanitary sewer collection system. Until there comes that inevitable emergency call due to a stoppage, then you have upset residents with sewage backed up in their toilets. A very economical and quick method of determining if a new sewer line is straight and unobstructed is called "*Lamping*" and can be done with a mirror and a bright source of light, for example a headlight at night or sunlight.

Video inspection coupled with a good cleaning program can be a highly effective maintenance tool. By cleaning and root sawing your lines, restrictions caused by debris, roots and grease buildup can be prevented—thus drastically reducing the number of emergency backups and surcharge calls.

Sewage collection systems that have video inspection closed circuit television (CCTV) and cleaning programs, report drastic reductions in the number of emergency calls because the system was cleaned and potential trouble spots were located prior to problems occurring.



Top photograph, new manhole. Bottom, a repaired sewer main after being damaged by the water distribution department using a backhoe without locates.





## Rule to Protect Communities from Overflowing Sewers

The Environmental Protection Agency (EPA) has clarified and expanded permit requirements under the Clean Water Act for 19,000 municipal sanitary sewer collection systems in order to reduce sanitary sewer overflows.

The requirements will help communities improve some of our Nation's most valuable infrastructure –our wastewater collection systems–by requiring facilities to develop and implement new capacity, management, operation, and maintenance programs and public notification programs.

The 19,000 systems covered by this rule include 4,800 municipal satellite collection systems that will be directly regulated under the Clean Water Act for the first time. These requirements will result in fewer sewer overflows, leading to healthier communities, fewer beach closures, and fish and shellfish that are safer to eat.



Various damage from undesirable materials in the sewer system. Bottom, heavy grease from not being regularly pumped. Photograph credit John Bougham.



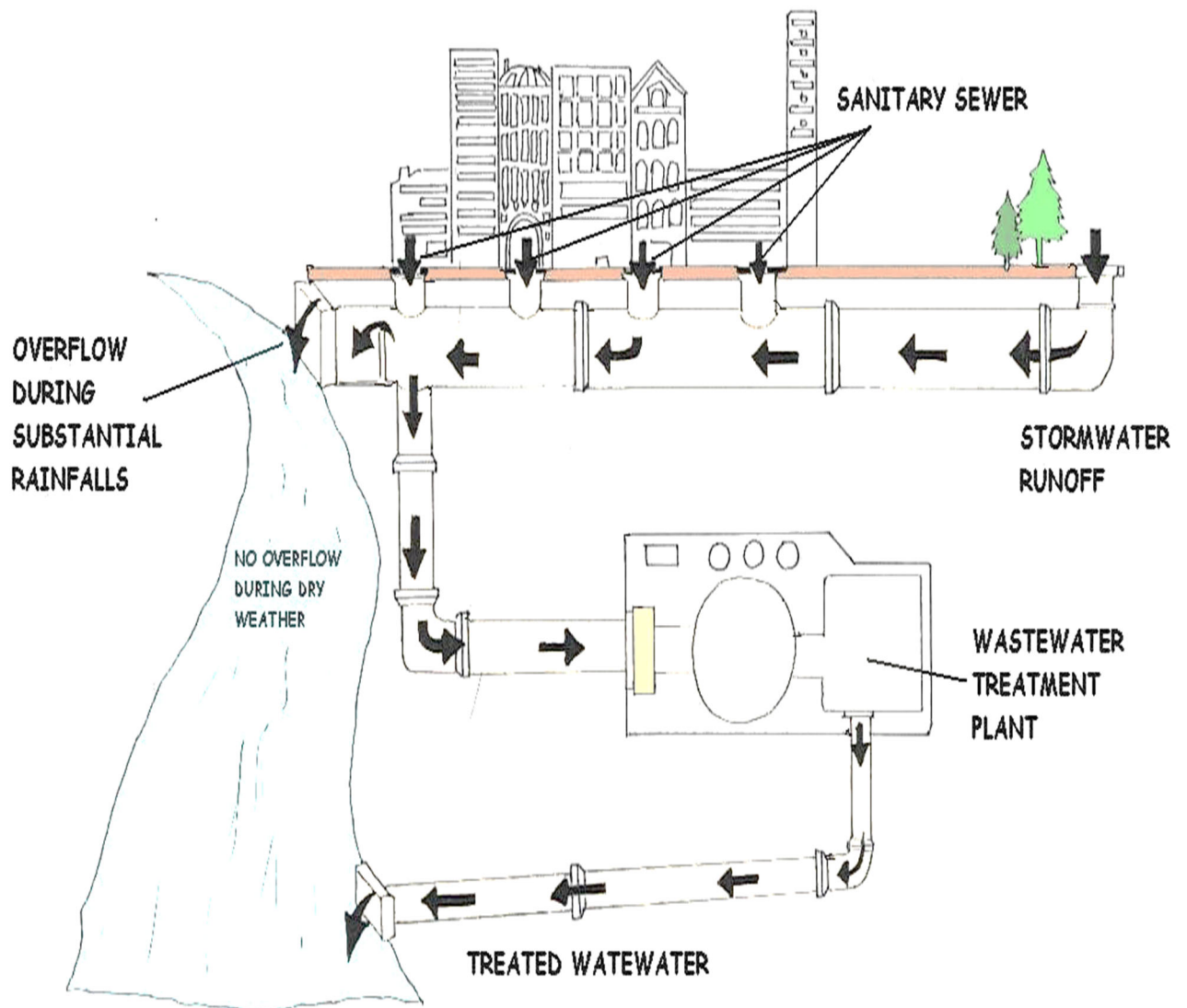

The complexity and expense associated with a utility's CMOM or MOM programs is specific to the size and complexity of the Publicly Owned Treatment Works (POTW) and related infrastructure. Factors such as population growth rate and soil/groundwater conditions also dictate the level of investment that should be made.

# Understanding the Gravity Sanitary Sewer System

## A Sanitary Sewer has Two Main Functions:

- To convey the designed peak discharge.
- Transport solids so that the deposits are kept at a minimum.

Sanitary sewers are designed to transport the wastewater by utilizing the potential energy provided by the natural elevation of the earth resulting in a downstream flow. This energy, if not designed properly, can cause losses due to free falls, turbulent junctions, and sharp bends. Sewer systems are designed to maintain proper flow velocities with minimum head loss. However, higher elevations in the system may find it necessary to dissipate excess potential energy.

Design flows are based on the quantity of wastewater to be transported. Flow is determined largely by population served, density of population, and water consumption. Sanitary sewers should be designed for peak flow of population. Stormwater inflow is highly discouraged and should be designed separate from the sanitary system.

Gravity-flow sanitary sewers are usually designed to follow the topography of the land and to flow full or nearly full at peak rates of flow and partly full at lesser flows. Most of the time the flow surface is exposed to the atmosphere within the sewer and it functions as an open channel. At extreme peak flows the wastewater will surcharge back into the manholes. This surcharge produces low pressure in the sewer system.

In order to design a sewer system, many factors are considered. The purpose of this topic is to aid in the understanding of flow velocities and design depths of flow. The ultimate goal for our industry is to protect the health of the customers we serve. This is achieved by prevention of sewer manhole overflows.

## Sewer System Capacity Evaluation - Testing and Inspection

The collection system owner or operator should have a program in place to periodically evaluate the capacity of the sewer system in both wet and dry weather flows and ensure the capacity is maintained as it was designed. The capacity evaluation program builds upon ongoing activities and the everyday preventive maintenance that takes place in a system.

The capacity evaluation begins with an inventory and characterization of the system components. The inventory should include the following basic information about the system:

- Population served
- Total system size (feet or miles)
- Inventory of pipe length, size, material and age, and interior and exterior condition as available
- Inventory of appurtenances such as bypasses, siphons, diversions, pump stations, tide or flood gates and manholes, etc., including size or capacity, material and age, and condition as available
- Force main locations, length, size and materials, and condition as available
- Pipe slopes and inverts
- Location of house laterals - both upper and lower

The system then undergoes general inspection which serves to continuously update and add to the inventory information.

### **Capacity Limitations**

The next step in the capacity evaluation is to identify the location of wet weather related SSOs, surcharged lines, basement backups, and any other areas of known capacity limitations. These areas warrant further investigation in the form of flow and rainfall monitoring and inspection procedures to identify and quantify the problem. The reviewer should ensure that the capacity evaluation includes an estimate of peak flows experienced in the system, an estimate of the capacity of key system components, and identification of the major sources of I/I that contribute to hydraulic overloading events.

The capacity evaluation should also make use of a hydraulic model. This model will help identify areas where there is a need to alleviate capacity limitations. Short and long term alternatives to address hydraulic deficiencies should be identified, prioritized, and scheduled for implementation. A sewer inspection is an important part of a sewer system capacity evaluation and determining your options or alternatives.

### **Flow Monitoring**

Fundamental information about the collection system is obtained by flow monitoring. Flow monitoring provides information on dry weather flows as well as areas of the collection system potentially affected by I/I. Flow measurement may also be performed for billing purposes, to assess the need for new sewers in a certain area, or to calibrate a model.

#### **There are three techniques commonly used for monitoring flow rates:**

- (1) permanent and long-term,
- (2) temporary, and
- (3) instantaneous.

Permanent installations are done at key points in the collection system such as the discharge point of a satellite collection system, pump stations, and key junctions. Temporary monitoring consists of flow meters typically installed for 30-90 days. Instantaneous flow metering is performed by collection system personnel, one reading is taken and then the measuring device is removed. The collection system owner or operator should have a flow monitoring plan that describes their flow monitoring strategy, or should at least be able to provide the following information:

- Purpose of the flow monitoring
- Location of all flow meters
- Type of flow meters
- Flow meter inspection and calibration frequency

### **Flow Monitoring Plan**

A flow monitoring plan should provide for routine inspection, service, and calibration checks (as opposed to actual calibration). In some cases, the data is calibrated rather than the flow meter. Checks should include taking independent water levels (and ideally velocity readings), cleaning accumulated debris and silt from the flow meter area, downloading data (sometimes only once per month), and checking the desiccant and battery state. Records of each inspection should be maintained.

## Infiltration and Inflow Sub-Section

### What is Infiltration/Inflow (I/I)?

Infiltration occurs when groundwater enters the sewer system through cracks, holes, faulty connections, or other openings. Inflow occurs when surface water such as storm water enters the sewer system through roof downspout connections, holes in manhole covers, illegal plumbing connections, or other defects.

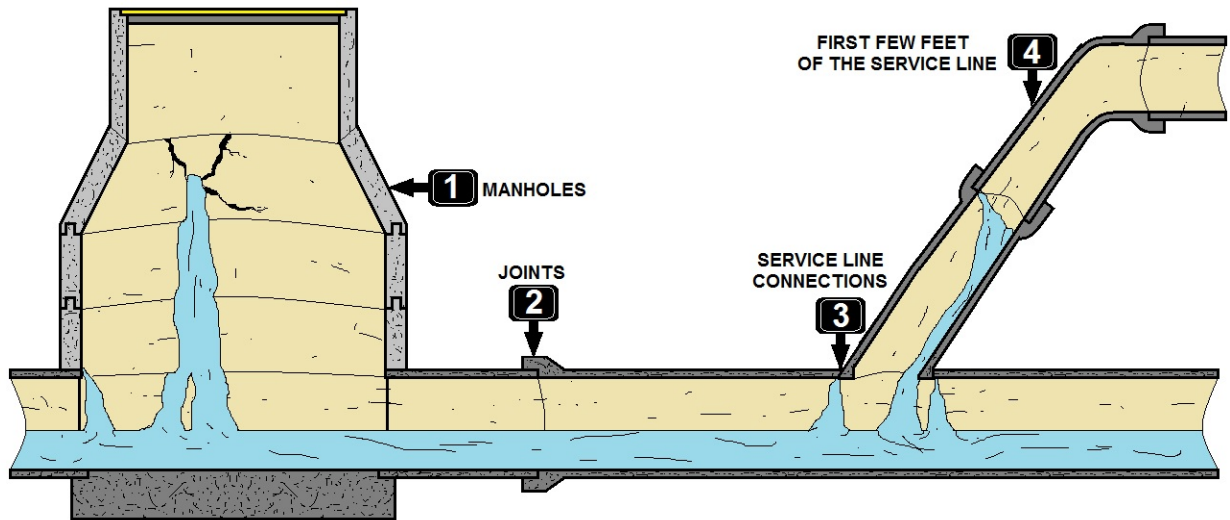

**INFLOW INTO SEWER SYSTEM EXAMPLE**

The sanitary sewer collection system and treatment plants have a maximum flow capacity of wastewater that can be handled. I/I, which is essentially clean water, takes up this capacity and can result in sewer overflows into streets and waterways, sewer backups in homes, and unnecessary costs for treatment of this water. It can even lead to unnecessary expansion of the treatment plants to handle the extra capacity. These costs are passed on to the consumer.

### I&I (Infiltration and Inflow)

- Infiltration is water (typically groundwater) entering the sewer underground through cracks or openings in joints.
- Inflow is water (typically stormwater or surface runoff) that enters the sewer from grates or unsealed manholes exposed to the surface.

### Determining I/I

Flow monitoring and flow modeling provide measurements and data used to determine estimates of I/I. Flow meters are placed at varying locations throughout the sewer collection system to take measurements and identify general I/I source areas. Measurements taken before and after a precipitation event indicate the extent that I/I is increasing total flow. Both infiltration and inflow increase with precipitation. Infiltration increases when groundwater rises from precipitation, and inflow is mainly stormwater and rainwater. Rainfall monitoring is also performed to correlate this data.

## Identifying Sources of I/I

A Sewer System Evaluation Survey (SSES) involves inspection of the sewer system using several methods to identify sources of I/I:

**Visual inspection** - accessible pipes, gutter and plumbing connections, and manholes are visually inspected for faults.

**Smoke testing** – smoke is pumped into sewer pipes. Its reappearance aboveground indicates points of I/I. These points can be on public property such as along street cracks or around manholes, or on private property such as along house foundations or in yards where sewer pipes lay underground.

**TV inspection** – camera equipment is used to do internal pipe inspections. The City will usually have one 2-3 person crew that can perform TV inspection on over 20 miles of sewer pipe per year.

**Dye testing** – Dye is used at suspected I/I sources. The source is confirmed if the dye appears in the sewer system.

Sources of I/I are also sometimes identified when sewer backups or overflows bring attention to that part of the system. The purpose of the SSES is to reduce these incidences by finding sources before they cause a problem.

## I/I Source Treatments

Repair techniques include manhole wall spraying, trenchless sewer pipe relining, manhole frame and lid replacement, and disconnecting illegal plumbing, drains, and roof downspouts.

Structural problems can cause major headaches. CCTV is one of the best tools available to check the condition of your buried assets. During CCTV field inspections, pipe defects and maintenance issues are discovered and classified using a standardized coding system. Following data analysis, structural condition information is used to estimate a pipe's performance, remaining useful life and to plan for the future and make decisions about pipe repair or replacement.

CCTV inspections also reveal maintenance issues, which aid the manager in making any necessary operation or maintenance changes.

- Collapses
- Fractures
- Sags
- Infiltration
- Inflow

## Hydraulic Capacity

Hydraulic capacity is a primary performance measure for a wastewater collection system. Capacity (both hydraulic and treatment) can be taken up by clean water entering the sewer collection system. It may be obvious, based on dry weather and wet weather flows, that rainwater or groundwater inflow or infiltration (I/I) is a problem. CCTV evaluation can determine the specific location and cause of I/I in many cases, however, flow data gathered by flow meters has been used to guide sewer system capacity management for decades.

Flow data can be used as a tool in condition assessment either to identify areas for further CCTV inspection or to quantify the severity of I/I identified during CCTV work.

- Excess flow
- Infiltration

- Inflow

Fortunately, there are several actions you can take after a manhole inspection reveals I&I.

Here are a few:

**1. Replace the manhole covers.**

- a. Cost – approximately \$200 per cover.
- b. I&I reduction could be \$350 per year or more if the covers are submerged during rain events.

**2. Chemical grouting to seal up leaky joints.**

- a. Cost – \$500 and up.
- b. Reduction could be as much as \$5,000 per year per manhole.

**3. Line the manhole.**

- a. Cost – approximately \$3,000.
- b. Could reduce costs by \$20,000 per year per manhole.

**Efficient Identification of Excessive I/I**

The owner or operator should have in place a program for the efficient identification of excessive I/I. The program should look at the wastewater treatment plant, pump stations, permanent meter flows, and rainfall data to characterize peaking factors for the whole system and major drainage basins. The reviewer should evaluate the program, including procedures and records associated with the flow monitoring plan. Temporary meters should be used on a “roving” basis to identify areas with high wet weather flows. Areas with high wet weather flows should then be subject to inspection and rehabilitation activities.

**Sewer System Testing**

Sewer system testing techniques are often used to identify leaks which allow unwanted infiltration into the sewer system and determine the location of illicit connections and other sources of stormwater inflow.

Two commonly implemented techniques include smoke testing and dyed water testing. Regardless of the program(s) implemented by the owner or operator, the reviewer should evaluate any procedures and records that have been established for these programs.

The reviewer should also evaluate any public relations program and assess how the owner or operator communicates with the public during these tests (i.e., when there is a possibility of smoke entering a home or building).



Smoke testing is a relatively inexpensive and quick method of detecting sources of inflow in sewer systems, such as down spouts, or driveway and yard drains, and works best for detecting cross connections and point source inflow leaks.

Smoke testing is not typically used on a routine basis, but rather when evidence of excessive I/I already exists. With each end of the sewer of interest plugged, smoke is introduced into the test section. Sources of inflow can then be identified when smoke escapes through them.

### **Areas Usually Smoke Tested**

- Drainage paths
- Ponding areas
- Cellars
- Roof leaders
- Yard and area drains
- Fountain drains
- Faulty service connections
- Abandoned building sewers

If the collection system owner or operator implements a regular program of smoke testing, the program should include a public notification procedure.

The owner or operator should also have procedures to define:

- How line segments are isolated.
- The maximum amount of line to be smoked at one time.
- The weather conditions in which smoke testing is conducted (i.e., no rain or snow, little wind and daylight only).

The results of positive smoke tests should be documented with carefully labeled photographs. Building inspections are sometimes conducted as part of a smoke testing program and, in some cases, may be the only way to find illegal connections. If properly connected to the sanitary sewer system, smoke should exit the vent stacks of the surrounding properties.

If traces of the smoke or its odor enter the building, it is an indication that gases from the sewer system may also be entering. Building inspections can be labor intensive and require advanced preparation and communication with the public.



## **Inflow and Infiltration Calculation/Determination Terms**

**Average Annual Flow** - The total annual volume divided by 365 days. This value is approximated by the mean of the twelve monthly average flows.

**Average Annual Infiltration** - The average of the monthly minimum flows.

**Average Annual Inflow** - From the average annual flow, subtract the base sanitary flow and average annual infiltration.

**Average Dry Weather Flow (ADW)** - Flow during a period of extended dry weather (7 to 14 days) and seasonally high groundwater. Flow includes sanitary flow and infiltration, and excludes significant industrial and commercial flows (assumes no inflow during dry weather conditions).

**Base Sanitary Flow (BSF)** - The portion of wastewater which includes domestic, commercial, institutional, and industrial sewage and specifically excludes infiltration and inflow. (See Estimating Base Flow, below).

**Delayed Inflow volume** - The portion of total inflow which is generated from indirect connections to the collection system or connections which produce inflow after a significant time delay from the beginning of a storm. Delayed inflow sources include: sump pumps, foundation drains, indirect sewer/drain cross-connections, etc. Rainfall induced infiltration cannot be distinguished from delayed inflow and is therefore included as part of delayed inflow. Delayed inflow sources have a gradual impact on the collection system and flow decreases gradually upon conclusion of the rainfall event, and after peak inflow caused by direct connections.

**Direct Inflow Volume**- The portion of total inflow volume which is from direct connections to the collection system such as catch basins, roof leaders, manhole covers, etc. These inflow sources allow stormwater runoff to rapidly impact the collection system.

**Dry Weather Flow (DWF)** - All flow in a sewer (includes sanitary flow and infiltration) except that caused directly by rainfall. Measured during a period of extended dry weather (7 to 14 days) and seasonally high groundwater. Groundwater

**Infiltration (GWI)** – Measured during average dry weather flow period (see above). The average of the low nighttime flows (midnight to 6 am) per day for the same time period, minus significant industrial or commercial nighttime flows.

**Hydrograph** - A graph showing stage (the height of a water surface above an established datum plane), flow, velocity, or other property of water with respect to time. Infiltration - Water other than sanitary wastewater that enters a sewer system from the ground through defective pipes, pipe joints, connections, or manholes. Infiltration does not include inflow.

**Inflow** - Water other than sanitary wastewater that enters a sewer system from sources such as roof leaders, cellar/foundation drains, yard drains, area drains, drains 4 from springs and swampy areas, manhole covers, cross connections between storm sewers and sanitary sewers, and catch basins. Inflow does not include infiltration.

**Inflow volume** - The total volume of inflow from a single storm event including both direct and delayed inflow. Total inflow is the area between the storm event hydrograph and the dry weather hydrograph.

**Maximum Daily Flow** - The highest flow during a 24 hour period.

**Maximum Daily Infiltration** - The highest daily flow at seasonal high groundwater after a dry period of three days or more minus the base sanitary flow.

**Maximum Weekly Infiltration** - The highest 7 day average flow at high groundwater after a dry period of three or more days minus the base sanitary flow.

**Maximum Monthly Infiltration** - The highest monthly average flow during dry or minimal rain period minus the base sanitary flow.

**Maximum Daily Inflow** - The highest daily wet weather flow minus the base sanitary flow and the infiltration prior to the rain event.

**Maximum Weekly Inflow** (includes delayed infiltration) - The highest 7 day average wet weather flow minus the base sanitary flow and the infiltration prior to the rain event.

**Maximum Monthly Inflow** - The highest monthly flow after subtracting the base sanitary flow and infiltration.

**Peak Hourly Dry Weather Flow** - The highest one hour flow after a dry period of three or more days.

**Peak Hourly Inflow** - The highest one hour flow rate during wet weather minus the base sanitary flow and the infiltration prior to the rain event.

**Peak Hourly Wet Weather Flow** – The highest one hour flow during a significant rain event.

**Peak Infiltration**- The highest nighttime (midnight to 6 am) flow during high groundwater (usually in early spring).

**Peak Instantaneous Wet Weather Flow** - The peak flow during a significant rain event day when the ground water is seasonally high.

**Peaking Factor** - The ratio of peak hourly flow to average daily flow.

**Rainfall-Induced Infiltration** - The short-term increase in infiltration which is the result of a rain event. Rainfall-induced infiltration is a portion of delayed inflow.

**Wet Weather Flow**- The highest daily flow during and immediately after a significant storm event. Includes sanitary flow, infiltration and inflow.

## Monitoring Flows

The sanitary portion of the wastewater flow can be estimated through two methods, which can be used to 'check' each other - flow meter data and water consumption (if all sewer customers are on metered water). The first method is to analyze the wastewater flow data at the treatment facility during a dry weather period of 7 to 14 days. It is useful to choose the dry weather period during seasonal high water as you will be able to determine the peak infiltration rate at the same time.

From the flow data, calculate the average daily flow for the dry weather period (Average Dry Weather – ADW - flow). The base sanitary flow (BSF) can be estimated by subtracting the groundwater infiltration (GWI) flow from the average daily dry weather wastewater (ADW) flow. (See Estimating Infiltration below).

In the second method, water usage records can be used to estimate the base sanitary flow for the sewered population. The best time to estimate flow using this method would be when outdoor water uses are low and wastewater from a residential area can be assumed to be the same as the billed water use. In the northeast, this would typically be in the winter months prior to landscaping and swimming pool use. Groundwater infiltration can be estimated as the difference between the monitored wastewater flow and the billed water use.

### Estimating Infiltration

Groundwater infiltration (GWI) can be estimated from influent flow data collected during a dry weather period at high groundwater. The dry weather period selected should be the same period as for estimating the BSF, however, it is more important to estimate GWI during high seasonal ground water. Dry weather is defined as when it has been at least three days without a rain event. During dry weather, inflow is expected to be zero.

During seasonal high groundwater, which usually occurs after snow melt and soil thaw, infiltration will be at its highest. During this period, the infiltration rate can be quantified by averaging the nighttime flows (midnight to 6 am) over several days, during dry weather conditions. The nighttime flows can be assumed to be mostly groundwater (after subtracting significant industrial or commercial nighttime flows). In most cases, the GWI rate will approximate the maximum weekly infiltration. The maximum daily infiltration will be higher and maximum monthly infiltration will be lower.

### Estimating Inflow

Inflow represents the influence of wet weather on the sewer system and is calculated by subtracting out the sanitary wastewater and infiltration flow during a time that the system has been influence by rain.

Flow data during a significant storm event should be compared to the dry weather data immediately preceding the storm when groundwater conditions are similar. The rate and volume of inflow can be estimated by subtracting the base sanitary flow and infiltration flow data from the wet weather flow data. The peak inflow rate and the total inflow volume can be calculated from the flow records.

The peak inflow rate is the largest rate difference, over a one hour period, between the storm event flow data and the dry weather flow prior to the event.

The total inflow volume from a storm event can be apportioned into two components: direct inflow and delayed inflow.

Direct inflow is the portion of the inflow which rapidly increases soon after the start of the storm and decreases swiftly upon conclusion of the event. The time it takes for inflow from the nearest sub-basin to reach the treatment facility can be estimated as the time difference between initiation of the storm event and the increase in observed flow. The direct inflow ends at a time after the conclusion of the storm approximately equal to the inflow response time from the furthest sub-basin.

Delayed inflow is the portion of the inflow which decreases gradually upon conclusion of the storm and after the peak inflow caused by direct connections.

Delayed inflow is the inflow beginning at the conclusion of direct inflow and ending at a time when dry weather flow resumes. It is expected that a portion of the delayed inflow includes rainfall-induced infiltration.

In some cases, a second storm will impact the flow data before dry weather flow resumes. When this occurs, the expected delayed inflow can be extrapolated from the flow data collected prior to the second storm.

### **Estimating Infiltration and Inflow (I&I)**

Maximum monthly I&I rate can be estimated by subtracting the BSF from the maximum monthly average flow. Average annual I&I rate can be estimated by subtracting the BSF rate from average annual flow rate. Annual I&I volume can be estimated by multiplying the average annual I&I rate by 365 days.

### **Sewer Flow Capacity**

Most sewers are designed with the capacity to flow half full for less than 15 inches in diameter; larger sewers are designed to flow at three-fourths flow. The velocity is based on calculated peak flow, which is commonly considered to be twice the average daily flow. Accepted standards dictate that the minimum design velocity should not be less than 2 fps (0.60 m/sec) or generally greater than 10 fps (3.5 m/sec) at peak flow.

A velocity in excess of 10 fps (3.5 m/sec) can be tolerated with proper consideration of pipe material, abrasive characteristics of the wastewater, turbulence, and thrust at changes of direction. The minimum velocity is necessary to prevent the deposition of solids.

### **Summary**

Sewers and treatment facilities are designed around expected average and maximum flows. Excess storm and groundwater entering the sewer system through I&I robs the system of its valuable capacity, puts a burden on operation and maintenance, and reduces the life expectancy of the treatment facility.

Sewer surcharging, back-ups and overflows all require emergency response and contribute to disruption of operations. Integrating I&I investigation and corrective action into a municipality's normal public works budget can allow an incremental approach to continuous improvement and help defer capacity expansion projects.

## Dye Testing

Dyed water testing may be used to establish the connection of a fixture or appurtenance to the sewer. It is often used to confirm smoke testing or to test fixtures that did not smoke. As is the case with smoke testing, it is not used on a routine basis, but rather in areas that have displayed high wet weather flows. Dyed water testing can be used to identify structurally damaged manholes that might create potential I/I problems. This is accomplished by flooding the area close to the suspected manholes with dyed water and checking for entry of dyed water at the frame-chimney area, cone or corbel, and walls of the manhole.

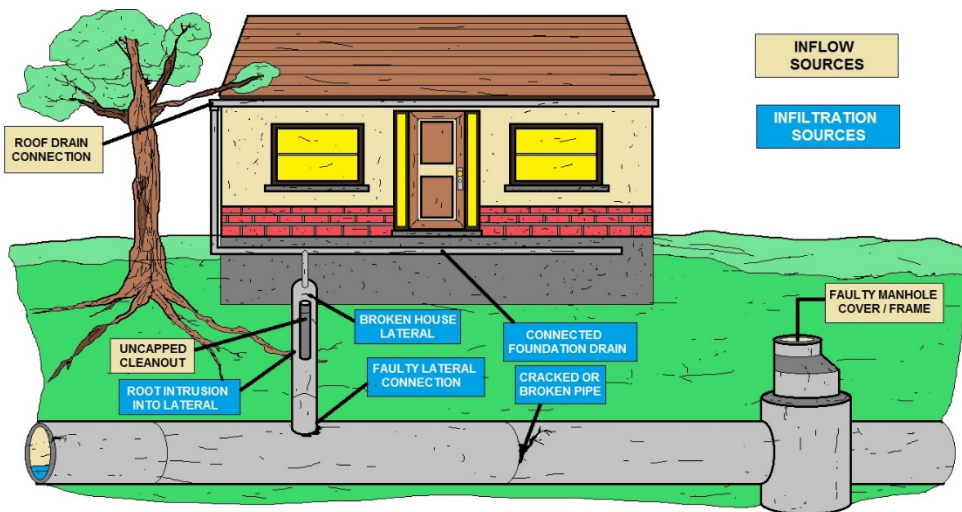

Technical Learning College

COMMON AREAS WHERE INFLOW / INFILTRATION OCCUR

## Sewer System Inspection

Visual inspection of manholes and pipelines is the first line of defense in the identification of existing or potential problem areas. Visual inspections should take place on both a scheduled basis and as part of any preventive or corrective maintenance activity. Visual inspections provide additional information concerning the accuracy of system mapping, the presence and degree of I/I problems, and the physical state-of-repair of the system. By observing the manhole directly and the incoming and outgoing lines with a mirror, it is possible to determine structural condition, the presence of roots, condition of joints, depth of debris in the line, and depth of flow.

The reviewer should examine the records of visual inspections to ensure that the following information is recorded:

- Manhole identification number and location.
- Cracks or breaks in the manhole or pipe (inspection sheets and/or logs should record details on defects.)
- Accumulations of grease, debris, or grit
- Wastewater flow characteristics (e.g., flowing freely or backed up.)
- Inflow - Infiltration (presence of clear water in or flowing through the manhole.)
- Presence of corrosion.
- Offsets or misalignments.
- Condition of the frame.
- Evidence of surcharge.
- Atmospheric hazard measurements (especially hydrogen sulfide.)
- If repair is necessary, a notation as to whether a work order has been issued.

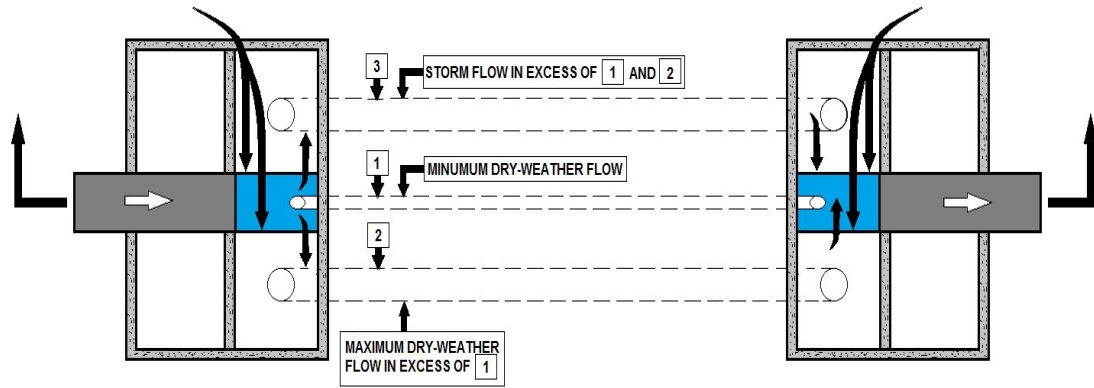

PLAN

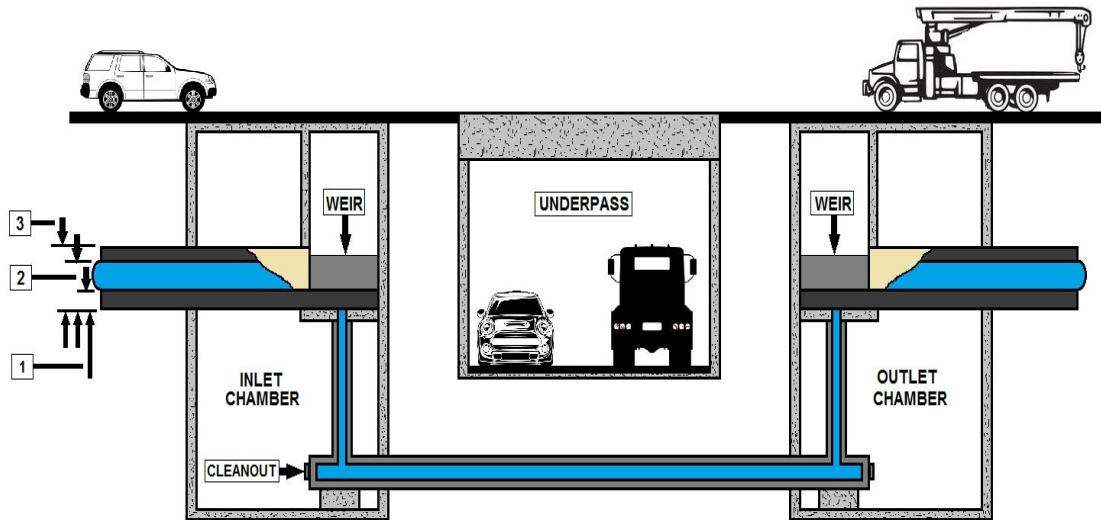

INVERTED SIPHON or SURPRESSSED SEWER  
(For Combined Sewage)



## Low-Pressure System Description and Operation

### Vacuum Sewers

Wastewater from one or more homes flows by gravity to a holding tank known as the valve pit. When the wastewater level reaches a certain level, sensors within the holding tank open a vacuum valve that allows the contents of the tank to be sucked into the network of collection piping. There are no manholes with a vacuum system; instead, access can be obtained at each valve pit. The vacuum or draw within the system is created at a vacuum station. Vacuum stations are small buildings that house a large storage tank and a system of vacuum pumps.

Vacuum sewer systems are limited to an extent by elevation changes of the land. Rolling terrain with small elevation changes can be accommodated, yet steep terrain would require the addition of lift stations like those used for conventional sewer systems. It is generally recommended that there be at least 75 properties per pump station for the use of a vacuum sewer system to be cost effective.

This minimum property requirement tends to make vacuum sewers most conducive for small communities with a relatively high density of properties per acre. The maintenance and operation of this system requires a full-time system operator with the necessary training. This can make the operation and maintenance costs of vacuum sewers exceed those of other systems.

### Applications

Vacuum collection and transportation systems can provide significant capital and ongoing operating cost advantages over conventional gravity systems, particularly in flat terrain, high water table, or hard rock areas. Vacuum sewer systems are installed at shallow depths, significantly reducing excavation, shoring and restoration requirements, and minimizing the disruption to the community. The alignment of vacuum mains is extremely flexible, without the need for manholes at changes in grade or direction.

Vacuum sewer mains can skip over and around other services or obstacles and can be used to achieve uphill flow. Turbulent velocities of 5 to 6m/sec are developed as the sewage and air passes through the interface valve. This disintegrates solids and reduces the risks of sewer blockages in a correctly designed and constructed vacuum system.

No electricity is required at the interface valve, enabling the system to be installed in virtually any location. Fractures in gravity systems may go undetected for a long time. A leak in a vacuum main will raise an alarm within minutes of the break. The mains have to be repaired for sewage transport to continue, ensuring up to date maintenance and eliminating deterioration and infiltration.

Due to the shallow depth of the installation, additional connections can be quickly and simply made by a small construction crew, thus reducing the disruption and restoration work normally required for conventional gravity sewers. Vacuum collection and transport systems have many applications in industry for collecting all forms of liquid waste, including toxic and radioactive fluids. Collection pipes may be installed above ground, overhead or in utility ducts.

The versatility of the vacuum sewer system can be employed in a variety of locations and situations, such as:

- Rural community sewerage schemes.
- Industrial redevelopments.

- Camping and caravan sites.
- New residential and industrial developments.
- Existing towns (especially where narrow streets or congested service corridors occur).
- Diversion of small sea outfalls.
- Hospital effluent collection.
- Airports/Shopping centers.
- Railway services.
- Replacement of failed gravity systems.
- Petrol-chemical industry.
- Food processing plants.
- Roof drainage.
- Retrofitting factories for the management of segregated wastestreams.
- Collection of toxic and radioactive waste.
- Condensate collection systems.
- Factory sewerage.
- Leachate from landfills.
- Spillage around tank farms.
- Collecting used oil and fluids.
- River and lakeside communities.
- Quayside redevelopments.
- Arctic communities.

### **Vacuum Interface Valves**

There is an interface between the vacuum within the vacuum mains and the atmospheric pressure is maintained within the vacuum interface chamber. When sewage is entering the system from a source and the sewage level in the chamber rises, it pressurizes air in the 63mm sensor line. This air pressure is transmitted by a hose to the controller/sensor unit, which opens the valve and the wastewater is rapidly drawn into the vacuum main. This suction of the sewer creates a vortex in the sump and air is drawn into the sewer with the sewage.

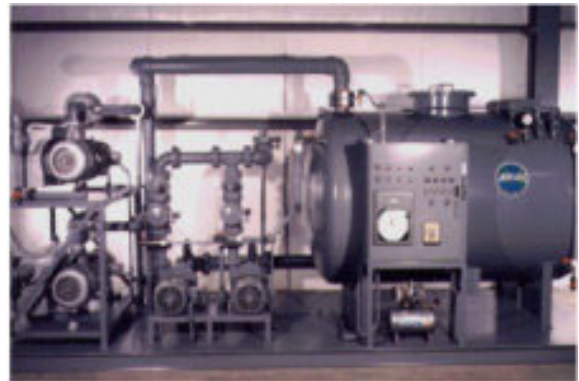

As the valve opens, a pneumatic timer in the controller/sensor unit starts a pre-set time cycle. The timer holds the valve open for sufficient time to draw all the sewage out of the sump and allows a designated amount of air to enter the system. The interface valve is capable of serving at least four equivalent tenements, and multiple valve chambers may be installed to serve higher flow rates. No electricity is required at the valve chamber. The vacuum valve is automatically operated by the pressure generated with the rising sewage level and the pneumatic timer, and actuated by the vacuum in the sewer.

Differential air pressure is the driving force in vacuum sewer systems. The vacuum sewer lines are under a vacuum of 16"-20" Hg (-0.5 to -0.7 bar) created by vacuum pumps located at the vacuum station. The pressure differential between the atmospheric pressure and the vacuum in the sewer lines of 7 to 10 psi (0.5 - 0.7 bar) provides the energy required to open the vacuum interface valves and to transport the sewage. Sewage flows by gravity from homes into a collection sump.



When 10 gallons (40 liters) accumulates in the sump, the vacuum interface valve located above the sump automatically opens and differential air pressure propels the sewage through the valve and into the vacuum main. Sewage flows through the vacuum lines and into the collection tank at the vacuum station.

Sewage pumps transfer the sewage from the collection tank to the wastewater treatment facility or nearby gravity manhole. There are no electrical connections required at the home. Power is necessary only at the vacuum station.

### **Valve Pit Package**

The Valve Pit Package connects the homes to the vacuum sewer system. Raw sewage flows by gravity from up to four homes into a sealed fiberglass sump. Located above the sewage sump and surrounded by a fiberglass valve pit is a 3" (90 mm) vacuum interface valve, which is pneumatically controlled and operated. Vacuum from the sewer line opens the valve and outside air from a breather pipe closes it.

Sewage level sensing is remarkably simple. As the sewage level rises, air trapped in the empty 2" (50 mm) diameter sensor pipe pushes on a diaphragm in the valve's controller/sensor unit, signaling the valve to open. When ten gallons of sewage accumulates in the sump the valve automatically opens. The differential air pressure propels the sewage at velocities of 15-18 feet per second (4.5 - 5.5 m/s), disintegrating solids while being transported to the vacuum station. The valve stays open for four to six seconds during this cycle.

Atmospheric air used for transport enters through the 4" (100 mm) screened air intake on the gravity line. There are no odors at this air inlet due to the small volumes of sewage (10 gallons - 40 liters) and short detention times in the sump. The valve is 3" and designed for handling nominal 3" (75 mm) solids. Homes connected to vacuum sewers don't require any special plumbing fixtures. Typically one valve pit package serves two homes. Install the valve pit package in the street, if desired. With the optional traffic cast iron cover the valve pit package has a water loading rating.

### **Vacuum Lines**

Vacuum sewer lines are installed in narrow trenches in a saw tooth profile for grade and uphill transport. Vacuum lines follow grade for downhill transport. Vacuum lines are slightly sloped (0.2%) towards the collection station. Unlike gravity sewers that must be laid at a minimum slope to obtain a 2 ft./sec. (0.6 m/s) scouring velocity, vacuum has a flatter slope since a high scouring velocity is a feature of vacuum sewage transport.

### **Line Sizes**

The vacuum service line from the valve to the main in the street is 3" diameter (90 mm). The vacuum mains are 4", 6", 8" and 10" diameter (110 mm to 250 mm) schedule 40 or SDR 21 gasketed PVC pipe. PE pipe can also be used. In general, a potential vacuum loss is associated with every lift. This limits the length of each vacuum line to about 2 to 3 miles (3 to 5 km) in flat terrain. Elevation changes can extend or reduce this range. Longer distances are possible depending on local topography.

## **Vacuum Station**

The vacuum station is similar in function to a lift station in a gravity sewer system. Sewage pumps transfer the sewage from the collection tank, through a force main, to the treatment plant. Unlike a lift station, the vacuum station has two vacuum pumps that create vacuum in the sewer lines and an enclosed collection tank.

## **Vacuum Pumps**

The vacuum pumps maintain the system vacuum in the 16" to 20" mercury vacuum (-0.5 to -0.7 bar) operating range. Vacuum pumps typically run 2 to 3 hours each per day (4 to 6 hours total) and don't need to run continuously since the vacuum interface valves are normally closed. As sewage enters the system, driven by air at atmospheric pressure, the system vacuum will slowly decrease from 20" to 16" Hg. The vacuum pumps are sized to increase the system vacuum from 16" to 20" Hg in three minutes or less.

Typical vacuum pump sizes are 10, 15, and 25 horsepower (7.5, 11 and 18.6 kw). Busch rotary vane vacuum pumps are standard. The two non-clog sewage pumps are each sized for peak flow. The collection tank is steel or fiberglass and is sized according to flow, with typical sizes ranging from 1,000 to 4,000 gallons (3.8 to 15 cubic meters). The incoming vacuum lines connect individually to the collection tank, effectively dividing the system into zones. A stand-by generator keeps the vacuum sewer system in operation during extended power outages. An automatic telephone dialer alerts the operator to alarm conditions.

## **Review**

### **Pressure Sewers**

Instead of relying on gravity, pressure sewers utilize the force supplied by pumps, which deliver the wastewater to the system from each property. Since pressure sewers do not rely on gravity, the system's network of piping can be laid in very shallow trenches that follow the contour of the land.

There are two kinds of pressure sewer systems, based upon the type of pump used to provide the pressure. Systems that use a septic tank/effluent pump combination are referred to as STEP pressure sewers.

Like the small diameter gravity system, STEP pressure sewers utilize septic tanks to settle out the solids; this allows for the use of piping that is extremely narrow in diameter. The effluent pump delivers the wastewater to the sewer pipes and provides the necessary pressure to move it through the system. The other type of pressure sewer uses a grinder pump.

Wastewater from each property goes to a tank containing a pump with grinder blades that shred the solids into tiny particles. Both solids and liquids are then pumped into the sewer system. Because the effluent contains a mixture of solids as well as liquids, the diameter of the pipes must be slightly larger. However, grinder pumps eliminate the need to periodically pump the septic tanks for all the properties connected to the system.

Both the STEP and grinder systems are installed with high water alarms. Because of the addition of the pumps, pressure sewers tend to require more operation and maintenance than small diameter gravity sewers.

Operators can usually be hired on a part time basis, as long as someone is on call at all times. Operators will need training on both the plumbing and electrical aspects of the system.

## Manhole Sub-Section

Manholes should undergo routine inspection typically every one to five years. There should be a baseline for manhole inspections (e.g., once every two years) with problematic manholes being inspected more frequently. The reviewer should conduct visual observation at a small but representative number of manholes for the items listed below.

There are various pipeline inspection techniques, the most common include: lamping, camera inspection, sonar, and CCTV. These will be explained further in the following sections.

### Sewer System Inspection Techniques

Sewer inspection is an important component of any maintenance program. There are a number of inspection techniques that may be employed to inspect a sewer system. The reviewer should determine if an inspection program includes frequency and schedule of inspections and procedures to record the results. Sewer system cleaning should always be considered before inspection is performed in order to provide adequate clearance and inspection results.

Additionally, a reviewer should evaluate records maintained for inspection activities, including whether information is maintained on standardized logs, and should include:

- Location and identification of line being inspected.
- Pipe size and type.
- Name of personnel performing inspection.
- Distance inspected.
- Cleanliness of the line.
- Condition of the manhole with pipe defects identified by footage from the starting manhole.
- Results of inspection, including estimates of I/I.

When designing a wastewater system, the design engineer begins by first determining the types and quantities of sewage to be handled. This is accomplished through a careful study of the area to be served. The design engineer bases his design on the average daily use of water per person in the area to be served. A typical value is 100 gallons per person per day. But, the use of water is not constant.

Use is greater in the summer than in the winter and greater during the morning and evening than it is in the middle of the day or at night. Therefore, the average daily flow (based on the average utilization) is multiplied by a peak flow factor to obtain the design flow.

Typical peak flow factors range from 4 to 6 times for small areas down to 1.5 to 2.5 times for larger areas. An allowance for unavoidable infiltration of surface and subsurface water into the lines is sometimes added to the peak flow to obtain the design flow.

A typical infiltration allowance is 500 gallons per inch of pipe diameter per mile of sewer per day. From the types of sewage and the estimated design flow, the engineer can then tentatively select the types, sizes, slopes, and distances below grade of the piping to be used for the system.



Upon acceptance of the preliminary designs, final design may begin. During this phase, adjustments to the preliminary design should be made as necessary, based upon additional surveys, soil analysis, or other design factors. The final designs should include a general map of the area that shows the locations of all sewer lines and structures.

They also should include detailed plans and profiles of the sewers showing ground elevations, pipe sizes and slopes, and the locations of any appurtenances and structures, such as manholes and lift stations.

Construction plans and details are also included for those appurtenances and structures.



Newly finished Manhole and Laterals

#### **Lead and Oakum Joint, Compression Joint and No-Hub Joints**

These types of joints are used to connect cast-iron soil pipes (CISP) and fittings. In lead and oakum joints, oakum (made of hemp impregnated with bituminous compound and loosely twisted or spun into a rope or yarn) is packed into the hub completely around the joint, and melted lead is poured over it. In compression joints, an assembly tool is used to force the spigot end of the pipe or fitting into the lubricated gasket inside the hub. A no-hub joint uses a gasket on the end of one pipe and a stainless steel shield and clamp assembly on the end of the other pipe.

#### **Mortar or Bituminous Joints**

This type of joint is common to vitrified clay and concrete pipes and fittings. Mortar joints may be made of grout (a mixture of cement, sand, and water).

The use of **SPEED SEAL JOINTS** (rubber rings) in joining vitrified clay pipe has become widespread. Speed seal joints eliminate the use of oakum and mortar joints for sewer mains. This type of seal is made a part of the vitrified pipe joint when manufactured. It is made of polyvinyl chloride and is called a plastisol joint connection

## Closed Circuit Television (CCTV) Inspection Sub-Section

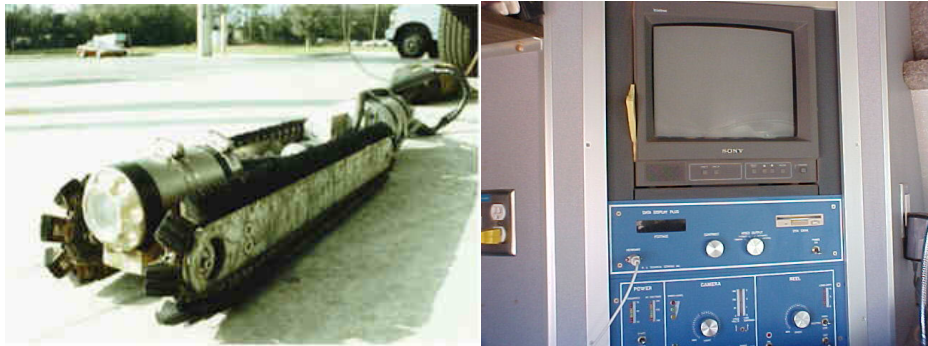

### Camera Inspection

Lamping involves lowering a still camera into a manhole. The camera is lined up with the centerline of the junction of the manhole frame and sewer. A picture is taken down the pipe with a strobe-like flash. A disadvantage of this technique is that only the first 10-12 feet of the pipe can be inspected upstream and downstream of the access point. Additionally, it has limited use in small diameter sewers. The benefits of this technique include not requiring confined space entry and little equipment and set-up time is required.

Camera inspection is more comprehensive than lamping in that more of the sewer can be viewed. A still camera is mounted on a floatable raft and released into a pipe. The camera takes pictures with a strobe-like flash as it floats through the sewer pipe. This technique is often employed in larger lines where access points are far apart. Similar to lamping, portions of the pipe may still be missed using this technique.

Obviously, there also must be flow in the pipe for the raft to float. This technique also does not fully capture the invert of the pipe and its condition. Sonar is a newer technology deployed similarly to CCTV cameras, and described in more detail below.

The sonar emits a pulse which bounces off the walls of the sewer. The time it takes for this pulse to bounce back provides data and an image of the interior of the pipe, including its structural condition. A benefit of this technique is that it can be used in flooded or inaccessible sections of the sewer. The drawback is that the technique requires heavy and expensive equipment.

Sewer scanner and evaluation is an experimental technology where a 360-degree scanner produces a full digital photograph of the interior of the pipe. This technique is similar to sonar in that a more complete image of a pipe can be made than with CCTV, but not all types of sewer defects may be identified as readily (i.e., infiltration, corrosion).

### Closed Circuit Television (CCTV) Inspections

Closed Circuit Television (CCTV) inspections are a helpful tool for early detection of potential problems. This technique involves a closed-circuit camera with a light which is self-propelled or pulled down the pipe. As it moves it records the interior of the pipe. CCTV inspections may be done on a routine basis as part of the preventive maintenance program, as well as part of an investigation into the cause of I/I.

CCTV, however, eliminates the hazards associated with confined space entry. The output is displayed on a monitor and videotaped. A benefit of CCTV inspection is that a permanent visual record is captured for subsequent reviews.

A remotely controlled TV camera on the top left is utilized by crews to identify and video tape problem areas within the system. By using this equipment, staff can determine what the cause of the problem is, what materials will be needed for repair, and where the problem area is.

Repairs can be made quickly without digging up large areas to find and correct a problem, as was done in the past. There are many reasons for inspecting sewer lines with a closed circuit television (CCTV). All of the following are valid reasons; locating sources of inflow and infiltration, locating buried manholes, and locating illegal sewer taps such as industrial or storm drains.



The Televising Van should be equipped with two cameras, one color camera for televising main sanitary lines and one color or black & white camera for televising house services (connection from the main sanitary line to a house).

## Sewer Flow Measurements

Flow measurements performed for the purpose of quantifying I/I are typically separated into three components: base flow, infiltration, and inflow. Base flow is generally taken to mean the wastewater generated without any I/I component. Infiltration is the seepage of groundwater into pipes or manholes through defects such as cracks, broken joints, etc. Inflow is the water which enters the sewer through direct connections such as roof leaders, direct connections from storm drains or yard, area, and foundation drains, the holes in and around the rim of manhole covers, etc.

Many collection system owners or operators add a third classification: rainfall induced infiltration (RII). RII is stormwater that enters the collection system through defects that lie so close to the ground surface that they are easily reached. Although not from piped sources, RII tends to act more like inflow than infiltration.

In addition to the use of flow meters, which may be expensive for a small owner or operator, other methods of inspecting flows may be employed, such as visually monitoring manholes during low-flow periods to determine areas with excessive I/I. For a very small system, this technique may be an effective and low-cost means of identifying problem areas in the system which require further investigation.



Inside a new manhole, the Invert is the inside bottom of the pipe. The Invert is used to determine the depth which is used to determine the Rise or Slope of the pipe.

The formula for figuring the slope is: rise divided by run.



**Smoke Testing** is accomplished by forcing a non-toxic smoke into the sewer system and looking for locations where it is improperly exiting.

These locations are considered illegal connections in that they allow stormwater directly or indirectly to enter the sanitary sewer system.

Typical illegal connections found are roof drains tied directly into the system, abandoned customer sewer lines that were not properly capped, as well as an occasional broken sewer line.



Raising the Ring, jackhammer, install the crown, patch the street.



## Sewer Flow Capacity

Most sewers are designed with the capacity to flow half full for less than 15 inches in diameter; larger sewers are designed to flow at three-fourths flow. The velocity is based on calculated peak flow, which is commonly considered to be twice the average daily flow. Accepted standards dictate that the minimum design velocity should not be less than 0.60 m/sec (2 fps) or generally greater than 3.5 m/sec (10 fps) at peak flow. A velocity in excess of 3.5 m/sec (10 fps) can be tolerated with proper consideration of pipe material, abrasive characteristics of the wastewater, turbulence, and thrust at changes of direction. The minimum velocity is necessary to prevent the deposition of solids.



Examples of various sewer flow measuring devices

### The Use of a Dye at the Manhole to Determine the Velocity is Done as Follows:

1. Insert dye upstream and begin timing until the dye is first seen at the downstream manhole ( $t_1$ ); and
2. Total the travel time, and the insertion time from the time the dye is no longer seen at the downstream manhole ( $t_2$ ).

Once this is complete, add ( $t_1 + t_2$ ) then divide it by 2. This will give you the total average time for the dye. In order to calculate the velocity the travel time is divided by the distance between manholes (note that the time needs to be converted to seconds):

$$\text{Velocity, ft/sec} = \frac{\text{Distance, ft}}{\text{Average time, sec}}$$

There are devices available to measure flow measurements; they all are based on the principle of the cross-sectional area of the flow in a sewer line. This is done by using the table below.

Once this has been determined, then the following equations can be used:

Q, cubic feet of flow = Area, sq ft multiplied by Velocity, ft/sec

d/D	Factor	d/D	Factor	d/D	Factor	d/D	Factor
0.01	0.0013	0.16	0.0811	0.31	0.2074	0.46	0.3527
0.02	0.0037	0.17	0.0885	0.32	0.2167	0.47	0.3627
0.03	0.0069	0.18	0.0961	0.33	0.2260	0.48	0.3727
0.04	0.0105	0.19	0.1039	0.34	0.2355	0.49	0.3827
0.05	0.0174	0.20	0.1118	0.35	0.2350	0.50	0.3927
0.06	0.0192	0.21	0.1199	0.36	0.2545	0.51	0.4027
0.07	0.0242	0.22	0.1281	0.37	0.2642	0.52	0.4127
0.08	0.0294	0.23	0.1365	0.38	0.2739	0.53	0.4227
0.09	0.0350	0.24	0.1449	0.39	0.2836	0.54	0.4327
0.10	0.0409	0.25	0.1535	0.40	0.2934	0.55	0.4426
0.11	0.0470	0.26	0.1623	0.41	0.3032	0.56	0.4526
0.12	0.0534	0.27	0.1711	0.42	0.3130	0.57	0.4625
0.13	0.0600	0.28	0.1800	0.43	0.3229	0.58	0.4724
0.14	0.0668	0.29	0.1890	0.44	0.3328	0.59	0.4822
0.15	0.0739	0.30	0.1982	0.45	0.3428	0.60	0.4920

***This table works as follows:***

To determine the cross-sectional flow for a 12-inch sewer main with a flow depth of 5 inches you would first:

**d** or depth 5 inches divided by **D** or diameter 12 inches equals 0.42 **d/D**. using the table above find the correct factor for 0.42 d/D.

The factor equals 0.3130, now calculate the cross-sectional area using the following formula:

$$\text{Pipe Cross-sectional Area, sq ft} = \frac{(\text{Factor})(\text{Diameter, in})^2}{144 \text{ sq in/sq ft}}$$

$$\frac{(0.3130)(12 \text{ in})^2}{144 \text{ sq in/sq ft}}$$

$$= 0.0313 \text{ sq ft}$$

Once the Velocity and the cross-sectional area have been determined, the calculation for flow rate is used. This formula is as followed:

$$\mathbf{Q, \text{ cubic feet per second} = (\text{Area, sq ft}) (\text{Velocity, ft/sec})}$$

Once this calculation is made, cubic feet can be converted to gallons by multiplying it by 7.48 gal/cubic feet and seconds can be converted to minutes, hours or days by multiplying the gallons with the time.

## Sewer Line Mapping

The importance of maintaining accurate, current maps of the collection system cannot be overstated. Efficient collection system maintenance and repairs are unlikely if mapping is not adequate. Collection system maps should clearly indicate the information that personnel need to carry out their assignments. The collection system maps should contain information on the following:

- Main, trunk and interceptor sewers
- Building/house laterals
- Manholes
- Cleanouts
- Force mains
- Pump stations
- Service area boundaries
- Other landmarks (roads, water bodies, etc.)

Collection system maps should have a numbering system that uniquely identifies all manholes and sewer cleanouts. The system should be simple and easy to understand. Manholes and sewer cleanouts should have permanently assigned numbers and never be renumbered. Maps should also indicate the property served and reference its cleanout.

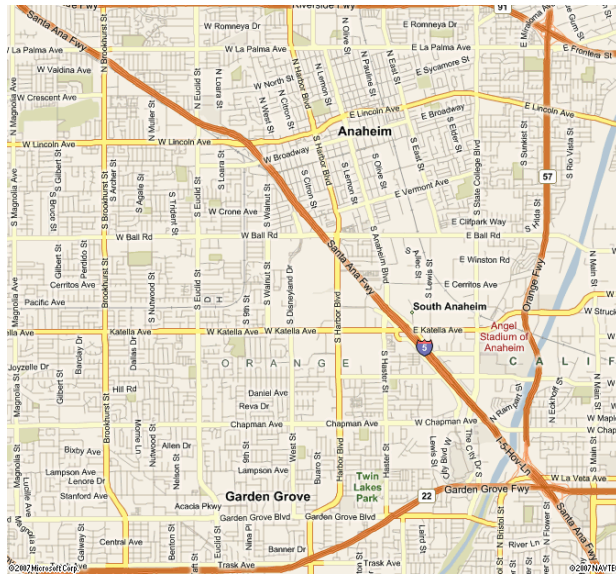

Sewer line maps should indicate the diameter, the length between the centers of manholes, and the slope or direction of flow. The dimensions of easements and property lines should be included on the maps. Other information that should be included on maps are access and overflow points, a scale, and a north arrow. All maps should have the date the map was drafted and the date of the last revision. Although optional, maps often include materials of pipe construction.

Maps may come in different sizes and scales to be used for different purposes. Detailed local maps may be used by maintenance or repair crews to perform the duties. However, these detailed local maps should be keyed to one overall map that shows the entire system.

## Geographic Information System (GIS)

GIS technology has made the mapping and map updating process considerably more efficient. GIS is a computerized mapping program capable of combining mapping with detailed information about the physical structures within the collection system. If a GIS program is being used by the owner or operator, the reviewer should ask if the program is capable of accepting information from the owner or operator's management program.

Specific procedures should be established for correction of errors and updating maps and drawings. Field personnel should be properly trained to recognize discrepancies between field conditions and map data and record changes necessary to correct the existing mapping system. Reviewers should check to see that maps and plans are available to the personnel in the office and to field personnel or contractors involved in all engineering endeavors.

### **Key Design Characteristics**

- Line locations, grades, depths, and capacities
- Maximum manhole spacing and size
- Minimum pipe size
- Pumping Station dimensions and capacities
- Drop manholes
- Flow velocities and calculations (peak flow and low-flow)
- Accessibility features
- Other technical specifications (e.g., materials, equipment)

### **New Sewer Construction**

The owner or operator should maintain strict control over the introduction of flows into the system from new construction. New construction may be public (i.e., an expansion of the collection system) or private (i.e., a developer constructing sewers for a new development).

Quality sanitary sewer designs keep costs and problems associated with operations, maintenance, and construction to a minimum. Design flaws are difficult to correct once construction is complete.

The reviewer should be aware that this has historically not been adequately addressed in some collection systems. The owner or operator should have standards for new construction, procedures for reviewing designs and protocols for inspection, start-up, testing, and approval of new construction. The procedures should provide documentation of all activities, especially inspection.

Reviewers should examine construction inspection records and be able to answer the following:

- Does the volume of records seem reasonable given system size?
- Do records reflect that the public works inspectors are complying with procedures?

The state or other regulatory authority may also maintain standards for new construction. The standards held by the owner or operator should be at least as stringent. Start-up and testing should be in accordance with the manufacturers' recommendations where applicable, and with recognized industry practices. Each step of the review, start-up, testing, and approval procedures should be documented.

The owner or operator approval procedure should reflect future ease of maintenance concerns. After construction is complete, a procedure for construction testing and inspection should be used. Construction supervision should be provided by qualified personnel such as a registered professional engineer.

## Wastewater Collection Section Summary

### Primary Collection System Problems

- a. Fats, oil, and greases (FOG) are a major problem; this is primarily applicable to municipal wastestreams.
- b. Odors, particularly those related to sulfides ( $H_2S$ ), are a constant concern, as are other mercaptans and some indoles (skatole).
- c. In many wastewater streams, particularly in industrial ones, problems center on highly toxic anions/cations that require chemical treatment of one sort or another.
- d. Various POTW's proscribe effluent limitations on phosphates, nitrates, and various other organic entities.

### Structural Sewer Problems

Structural problems can cause major headaches. CCTV is one of the best tools available to check the condition of your buried assets. During CCTV field inspections, pipe defects and maintenance issues are discovered and classified using a standardized coding system. Following data analysis, structural condition information is used to estimate a pipe's performance, remaining useful life and to plan for the future and make decisions about pipe repair or replacement.

CCTV inspections also reveal maintenance issues, which aid the manager in making any necessary operation or maintenance changes.

- Collapses
- Fractures
- Sags
- Infiltration
- Inflow

### Hydraulic Capacity

Hydraulic capacity is a primary performance measure for a wastewater collection system. Capacity (both hydraulic and treatment) can be taken up by clean water entering the sewer collection system. It may be obvious, based on dry weather and wet weather flows, that rainwater or groundwater inflow or infiltration (I/I) is a problem.

CCTV evaluation can determine the specific location and cause of I/I in many cases, however, flow data gathered by flow meters has been used to guide sewer system capacity management for decades.

Flow data can be used as a tool in condition assessment either to identify areas for further CCTV inspection or to quantify the severity of I/I identified during CCTV work.

- Excess flow
- Infiltration
- Inflow



## Wastewater Collection Post Quiz

### Collection System Defined

1. Decentralized systems are public sewer systems that serve established towns and cities and transport wastewater to a central location for treatment.  
A. True      B. False
2. Homes and other buildings that are not served by public sewer systems depend on \_\_\_\_\_ septic systems to treat and dispose of wastewater.
3. Most decentralized systems are \_\_\_\_\_ systems (wastewater is treated underground near where it is generated).
4. Centralized systems are more inexpensive, allow for greater control, require fewer people, and produce only one discharge to monitor instead of several. However, \_\_\_\_\_ systems can be useful, and this option should be evaluated on a case-by-case basis.
5. \_\_\_\_\_ are designed to collect both sanitary wastewater and storm water runoff.

### Collection System Operators' Purpose

6. Collection system operators are charged with protecting public health and the environment, and therefore must have documented proof of their certifications in the respective \_\_\_\_\_.
7. \_\_\_\_\_ and the professionals who maintain it operate at such a high level of efficiency, problems are very infrequent.
8. Collection system operators ensure that the system pipes remain clear and open. They eliminate obstructions and are constantly striving to improve flow characteristics. They keep the wastewater moving underground, unseen and unheard.  
A. True      B. False
9. Underground sanitary sewer pipes can clog or break, causing unplanned "overflows" of raw sewage that flood basements and streets.  
A. True      B. False
10. Storm sewers are not designed to quickly get rainwater off the streets during rain events.  
A. True      B. False
11. Combined sewers deliver both wastewater and storm water in the same pipe. Most of the time, combined sewers transport the wastewater and storm water to a treatment plant.  
A. True      B. False

12. The public often takes the wastewater collection system for granted. In truth, these operators must work hard to keep it functioning properly.

A. True      B. False

13. When there is too much rain, combined sewer systems cannot handle the extra volume and designed "overflows" of raw sewage into streams and rivers occur. The great majority of sewer systems have separated, not combined, sanitary and storm water pipes.

A. True      B. False

14. The maintenance of the sewer system is a semi-continuous cycle.

A. True      B. False

15. Outdated pump stations, undersized to carry sewage from newly developed subdivisions or commercial areas, will not create any potential overflow hazards, adversely affecting human health and degrading the water quality of receiving waters.

A. True      B. False

### **Understanding Gravity Sanitary Sewers**

16. Sanitary sewers are planned to transport the wastewater by utilizing the \_\_\_\_\_ provided by the natural elevation of the earth resulting in a downstream flow.

17. Sewer systems are designed to maintain proper flow velocities with?

### **Sewer System Capacity Evaluation - Testing and Inspection**

18. The collection system owner or operator should have a program in place to periodically evaluate this \_\_\_\_\_ in both wet and dry weather flows and ensure the capacity is maintained as it was designed.

### **Answers**

1. False, 2. Decentralized, 3. Onsite, 4. Decentralized, 5. Combined sewer systems, 6. Wastewater management system, 7. Wastewater collection system, 8. True, 9. True, 10. False, 11. True, 12. True, 13. True, 14. False, 15. False, 16. Potential energy, 17. Minimum head loss, 18. Capacity of the sewer system



## Chapter 5- COLLECTION SYSTEM O&M SECTION

**Section Focus:** You will learn the basics of the operation and maintenance of the collection system. At the end of this section, you the student will be able to describe the basics of proper operation and maintenance of the wastewater collection system. There is a post quiz at the end of this section to review your comprehension and a final examination in the Assignment for your contact hours.

**Scope/Background:** As a pretreatment inspector, you will need knowledge of many different concerns of the collections and wastewater treatment systems in order to properly identify the pretreatment (pass-through or interference) problem. Master's level knowledge of the collection system is essential for all pretreatment inspectors.

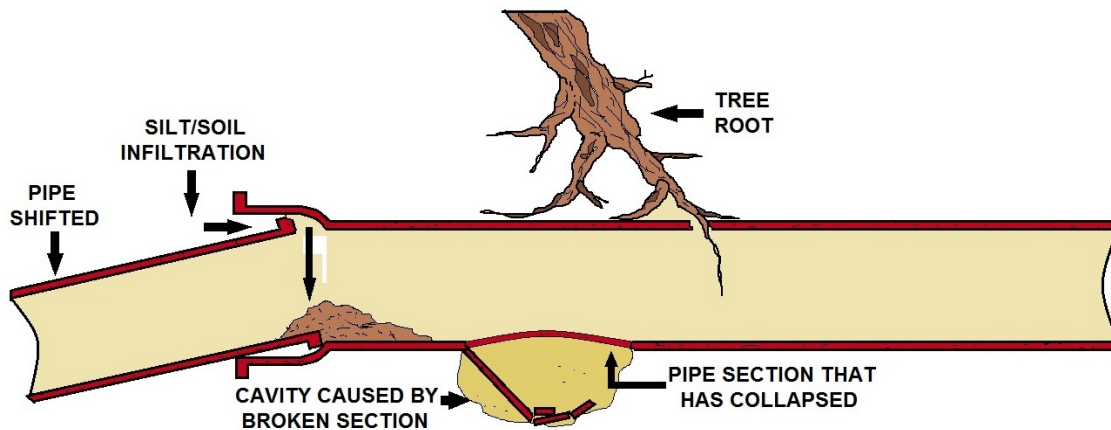

### BROKEN SEWER PIPE

Operation and maintenance of wastewater collection systems on a trouble or emergency basis has been the usual procedure and policy in many systems. Planned operation and preventive maintenance of the collection system has been delayed or omitted, primarily for political or financial reasons.

Routine preventative operations and maintenance activities for wastewater collection lines shall be performed by the system's personnel and outside contractors. A qualified outside contractor can also be utilized to perform hydraulic cleaning using a jet hydro-vac combination truck and mechanical cleaning using a rodding machine. Routine operations and maintenance activities including cleaning and removing roots from small and large diameter lines. The system's goal should be a minimum of cleaning between 20-30% of the sewers every year.

**Closed-circuit television (CCTV) is used to assess the condition of the sewers.**

There are four types of activities that the system or a CCTV contractor can also perform:

- 1) inspect new work,
- 2) inspect condition of older portions of the wastewater collection system,
- 3) routine inspection of approximately 10% of the wastewater collection, and 4) problem identification to determine the cause of selected overflow events. Manhole inspection, manhole coating (to prevent concrete deterioration) and manhole painting (for roach control) are also routinely performed.



Sewer filled with grass will damage your system, pumps, and upset the wastewater treatment system. Require your industrial users like golf courses to install grass, grease, and sand/oil interceptors.

Certain compounds and undesirable solids, like grease and grass clippings, can disturb this delicate balance and necessary process at the wastewater treatment facility.

There are compounds and mixtures that should never be introduced into a sanitary sewer system. These destructive compounds include but are not limited to: cleaning solvents, grease (both household and commercial), oils (both household and commercial), pesticides, herbicides, antifreeze and other automotive products.

## **Sewer Cleaning and Inspection Sub-Section**

Inspection and testing are the techniques used to gather information to develop operation and maintenance programs to ensure that new and existing wastewater collection systems serve their intended purposes on a continuing basis. Inspection and testing are necessary to do the following:

- Identify existing or potential problem areas in the collection system,
- Evaluate the seriousness of detected problems,
- Locate the position of problems, and
- Provide clear, concise and meaningful reports regarding problems.

Two major purposes of inspecting and testing are to prevent leaks from developing in the wastewater collection system and to identify existing leaks so they can be corrected. The existence of leaks in a wastewater collection system is a serious and often expensive problem. When a sewer is under a water table, infiltration can take place and occupy valuable capacity in the sewer and the downstream treatment plant. Sewers located above a water table can exfiltrate, allowing raw wastewater to pollute soil and groundwater.

As sewer system networks age, the risk of deterioration, blockages, and collapses becomes a major concern. As a result, municipalities worldwide are taking proactive measures to improve performance levels of their sewer systems. Cleaning and inspecting sewer lines are essential to maintaining a properly functioning system; these activities further a community's reinvestment into its wastewater infrastructure.

### **Inspection Techniques**

Inspection programs are required to determine current sewer conditions and to aid in planning a maintenance strategy. Ideally, sewer line inspections need to take place during low flow conditions. If the flow conditions can potentially overtop the camera, then the inspection should be performed during low flow times between midnight and 5 AM, or the sewer lines can be temporarily plugged to reduce the flow.

Most sewer lines are inspected using one or more of the following techniques:

- Closed-circuit television (CCTV).
- Cameras.
- Visual inspection.
- Lamping inspection.

Television (TV) inspections are the most frequently used, most cost efficient in the long term, and most effective method to inspect the internal condition of a sewer. CCTV inspections are recommended for sewer lines with diameters of 0.1-1.2 m (4 - 48 inches.) The CCTV camera must be assembled to keep the lens as close as possible to the center of the pipe. In larger sewers, the camera and lights are attached to a raft, which is floated through the sewer from one manhole to the next. To see details of the sewer walls, the camera and lights swivel both vertically and horizontally.

In smaller sewers, the cable and camera are attached to a sled, to which a parachute or droge is attached and floated from one manhole to the next. Documentation of inspections is very critical to a successful operation and maintenance (O&M) program.

CCTV inspections produce a video record of the inspection that can be used for future reference. In larger sewers where the surface access points are more than 300 1000 linear feet apart, camera inspections are commonly performed. This method requires less power than the CCTV, so the power cable is smaller and more manageable. Inspections using a camera are documented on Polaroid or digital still (computer jpeg) photographs that are referenced in a log book according to date, time, and location.

Visual inspections are vital in fully understanding the condition of a sewer system. Visual inspections of manholes and pipelines are comprised of surface and internal inspections. Operators should pay specific attention to sunken areas in the groundcover above a sewer line and areas with ponding water.

In addition, inspectors should thoroughly check the physical conditions of stream crossings, the conditions of manhole frames and covers or any exposed brickwork, and the visibility of manholes and other structures. For large sewer lines, a walk-through or internal inspection is recommended. This inspection requires the operator to enter a manhole, the channel, and the pipeline, and assess the condition of the manhole frame, cover, and chimney, and the sewer walls above the flow line.

When entering a manhole or sewer line, it is very important to observe the latest Occupational Safety and Health Administration confined space regulations. If entering the manhole is not feasible, mirrors can be used. Mirrors are usually placed at two adjacent manholes to reflect the interior of the sewer line. Lamping inspections are commonly used in low priority pipes, which tend to be pipes that are less than 20 years old.

### **Lamping**

Lamping is also commonly used on sewer projects where funds are extremely limited. In the lamping technique, a camera is inserted and lowered into a maintenance hole and then positioned at the center of the junction of a manhole frame and the sewer. Visual images of the pipe interior are then recorded with the camera.

Several specialized inspection techniques have been recently developed worldwide. This includes: Light-line based and sonar-based equipment that measures the internal cross-sectional profile of sewer systems.

Sonar technology could be very useful in inspecting depressed sewers (inverted siphons), where the pipe is continually full of water under pressure. Melbourne Water and CSIRO Division of Manufacturing Technology have introduced a new technology called PIRAT, which consists of an in-pipe vehicle with a laser scanner. This instrument is capable of making a quantitative and automatic assessment of sewer conditions. The geometric data that is gathered is then used to recognize, identify, and rate defects found in the sewer lines.

## Manhole Inspections - Sewer Inspections Recommendations

The information provided if employed is a good starting point for an inspection.

### **Manhole inspections should yield a report with the following information at a minimum:**

- Exact location of the manhole;
- Diameter of the clear opening of the manhole;
- Condition of the cover and frame, including defects that would allow inflow to enter the system;
- Whether cover is subject to ponding or surface runoff;
- The potential drainage area tributary to the defects;
- Type of material and condition of the chimney corbel cone and walls;
- Condition of steps and chimney and frame-chimney joint;
- Configuration of the incoming and outgoing lines (including drops); and
- Signs of frame-chimney leakage or damage to the frame's seal

### **Additionally, the following data can be obtained by entering the manhole and using equipment such as portable lamps, mirrors, rulers, and probe rods:**

- Type of material and condition of apron and trough;
- Any observed infiltration sources and the rate of infiltration;
- Indications of height of surcharge;
- Size and type of all incoming and outgoing lines; and
- Depth of flow indications of deposition and the characteristics of flow within all pipes.
- The condition of the manhole shaft;
- Any leakage in the channel;
- Any leakage between the manhole wall and the channel;
- Any damage or leakage where pipeline connects to the manhole; and
- Any flow obstructions.

### **Television Inspections**

Sewer pipe inspections of small diameter sewers for infiltration are most effective when a closed circuit television camera is employed.

### **Television inspections should provide the following information:**

- Definitions of problem(s)
- Determine if problem is in municipal sewer or private property sewer
- Effectiveness of existing cleaning program
- Future sewer cleaning requirements
- Sewer rehabilitation needs
- Ability to assess whether trenchless technology or excavation and replacement can solve the problem
- Ability to project repair budget
- Information to plan a permanent solution

## Planning is Required to Define the Inspections Goals.

### Inspections are performed to:

- Identify maintenance problems
- Determine general sewer conditions
- Identify extraneous flows

### The following data is useful to have prior to beginning the inspection:

- Sewer map or as-built plans to locate sewer
- Site specific data
- accessibility of deploying equipment at manholes
- depth of flow in sewer
- pipe diameter
- traffic connections
- safety requirement
- sewer cleaning
- sewer backup records
- sewer cleaning records
- influence of pump station discharges
- influence of industrial discharges

If such records are not available or kept, then a system to retain such information should be established.

### During the CCTV inspection the following information should be obtained:

Pipe structural condition	Pipe material	Joints
Joint interval distance	Pipe cracks	Root intrusion
Debris, sediment and/or oil and grease	Service connections	type
quadrant location	building number	active or inactive
rate of infiltration	Infiltration and inflow	Alignment
Sewer types	Sewer location	Sewer surface cover (depth)
Roadway surface material	Time of day	Weather conditions

### Inspection for Sources of Inflow

- are most readily achieved through smoke testing and/or dye testing.

### Smoke Testing of Sewers is Done to Determine:

- stormwater sewer connections
- proof that buildings or residences are connected to the sanitary sewer
- illegal connections such as roof leaders or downspouts, yard drains and industrial drains
- location of broken sewers due to settling of foundations, manholes and other structures
- location of uncharted manholes and diversion points

Dye testing can be used to verify connections of drains to sanitary or storm sewers. Dye testing can be used to verify the findings of smoke testing.

<b>Suggested Inspection And Maintenance Frequencies</b>	
<b>Task</b>	<b>Frequency in Years</b>
Video inspection/line testing (typical)	3 to 15
Video inspection/line testing (problem area)	1 to 3
Field check (problem area)	1
Walk alignment	1
Manhole/line lamping (typical)	3 to 15
Manhole/line lamping (problem area)	1 to 3
Cleaning (typical)	3 to 15
Cleaning (problem area)	0.5 to 3
System assessment	1
Source: Nelson, Richard E. "Collection System Maintenance: How Much is Enough?" Operation Forum, July 1996	

## **Sewer Cleaning Techniques and Schedules**

To maintain its proper function, a sewer system needs a cleaning schedule. There are several traditional cleaning techniques used to clear blockages and to act as preventative maintenance tools. When cleaning sewer lines, local communities need to be aware of EPA regulations on solid and hazardous waste as defined in 40 CFR 261. In order to comply with state guidelines on testing and disposal of hazardous waste, check with the local authorities.

Hydraulic cleaning developments have also been emerging on the international frontier. France and Germany have developed several innovative flushing systems using a 'dam break' concept.

### **Hydrass**

France has developed a flushing system called the Hydrass. The design of the Hydrass consists of a gate that pivots on a hinge to a near horizontal position. As the gate opens and releases a flow, a flush wave is generated that subsequently washes out any deposited sediments. Germany has also developed a similar system called GNA Hydrosel®. This is a flushing system that requires no electricity, no maintenance and no fresh water. The Hydrosel® consists of a hydraulically-operated gate and a concrete wall section constructed to store the flush water. This system can be installed into a large diameter sewer. There appears to be no limit on the flushing length, as more flush water may be stored without incurring any additional construction or operating costs.

Another example of such a technology is seen in the Brussels Sewer System. A wagon with a flushing vane physically moves along the sewer and disturbs the sediments so that they are transported with the sewer flow.

### **Public Education**

Although all of these methods have proven effective in maintaining sewer systems, the ideal method of reducing and controlling the materials found in sewer lines is education and pollution prevention. The public needs to be informed that common household substances such as grease and oil need to be disposed in the garbage in closed containers, and not into the sewer lines. This approach will not only minimize a homeowner's plumbing problems, but will also help keep the sewer lines clear.

In recent years, new methodologies and accelerated programs have been developed to take advantage of the information obtained from sewer line maintenance operations. Such programs incorporate information gathered from various maintenance activities with basic sewer evaluations to create a system that can remedy and prevent future malfunctions and failures more effectively and efficiently.

Some systems have attempted to establish a program that would optimize existing maintenance activities to reduce customer complaints, sanitary sewer overflows, time and money spent on sewer blockages, and other reactive maintenance activities. Their plan is based on maintenance frequencies, system performance, and maintenance costs over a period of time. This plan was developed using Geographical Information System (GIS) and historical data to show areas of complaints, back-ups, and general maintenance information for the area.



# Homeowner Sewer Diagrams

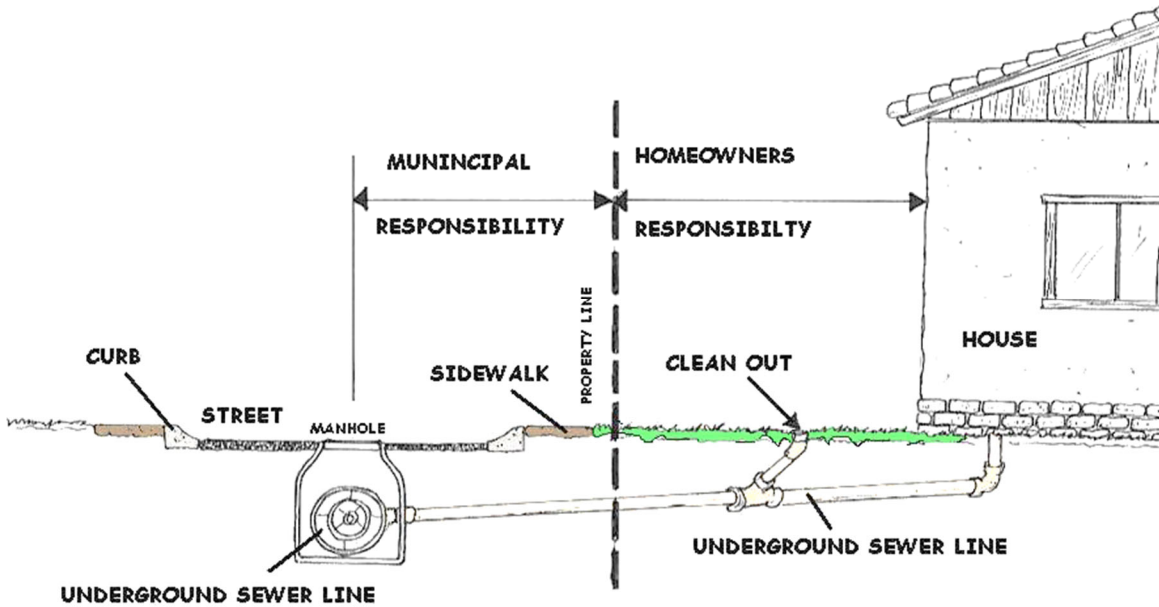
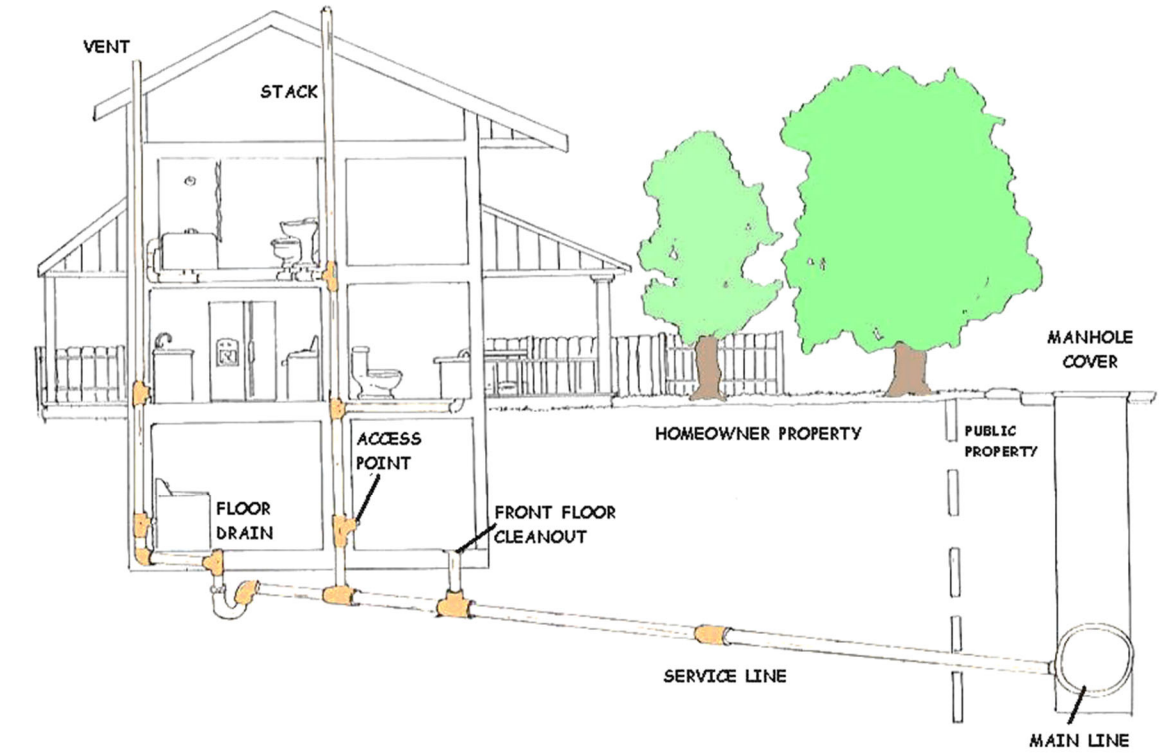

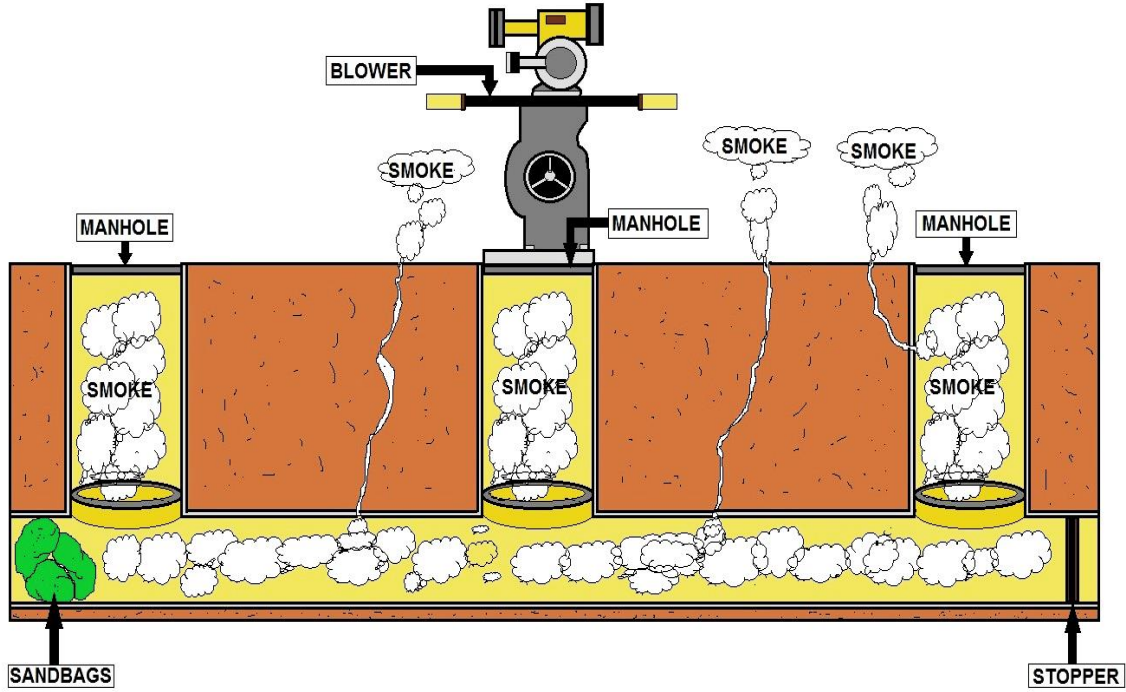

**SMOKE TEST IN SEWER MAIN**

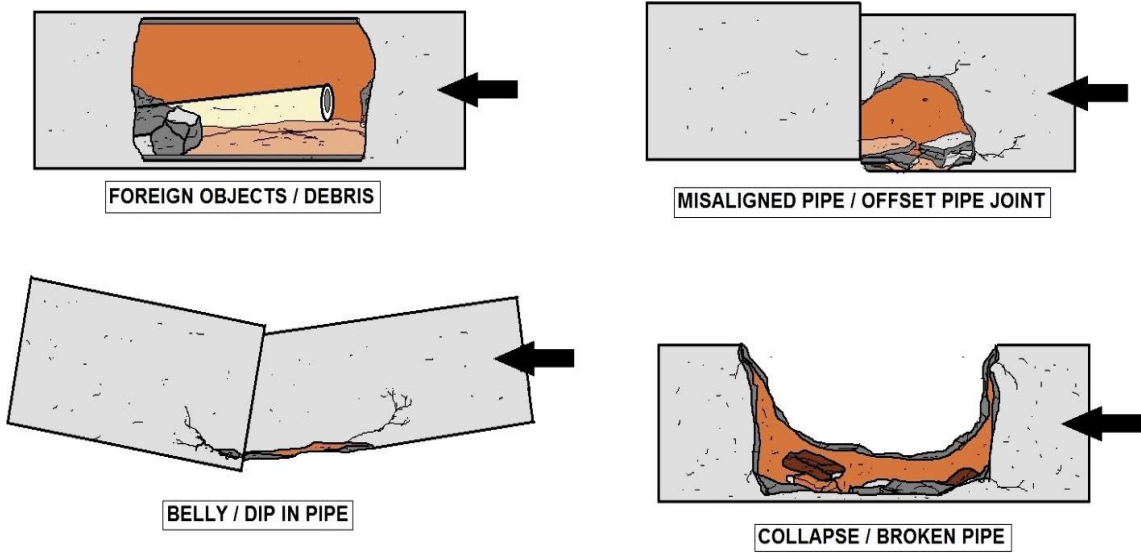

**COMMON CAUSES OF SEWER LATERAL BLOCKAGES**

# Common Sewer Problems and Solutions Diagrams

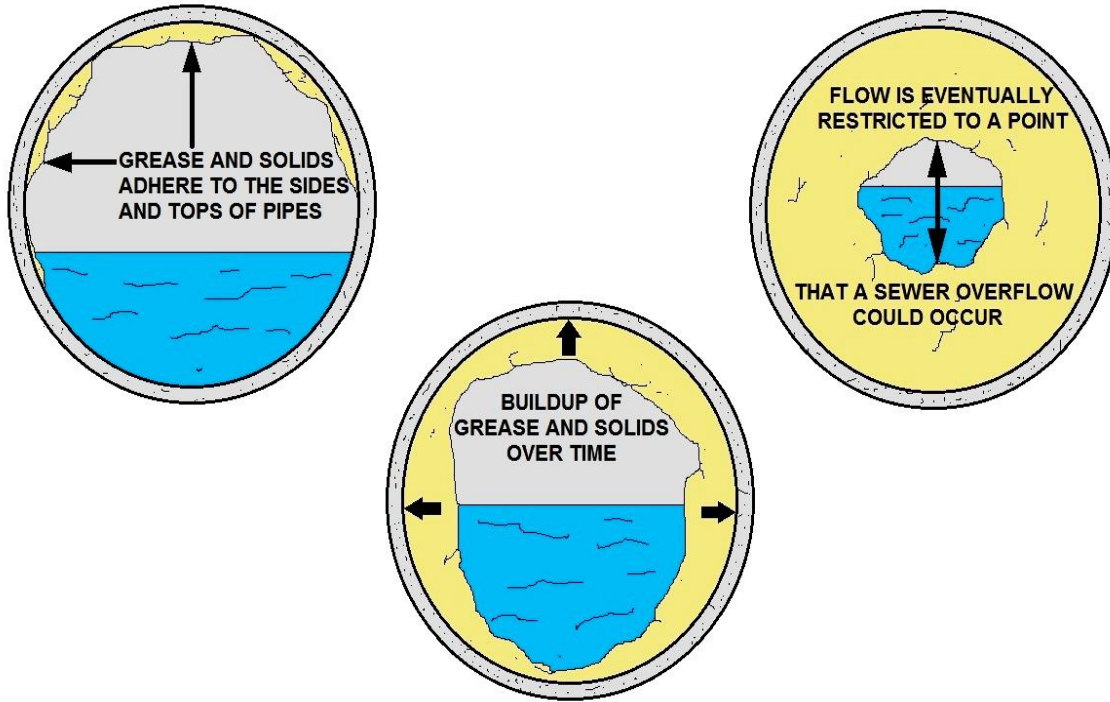

## EFFECTS OF GREASE AND SOLIDS ON SEWER FLOW

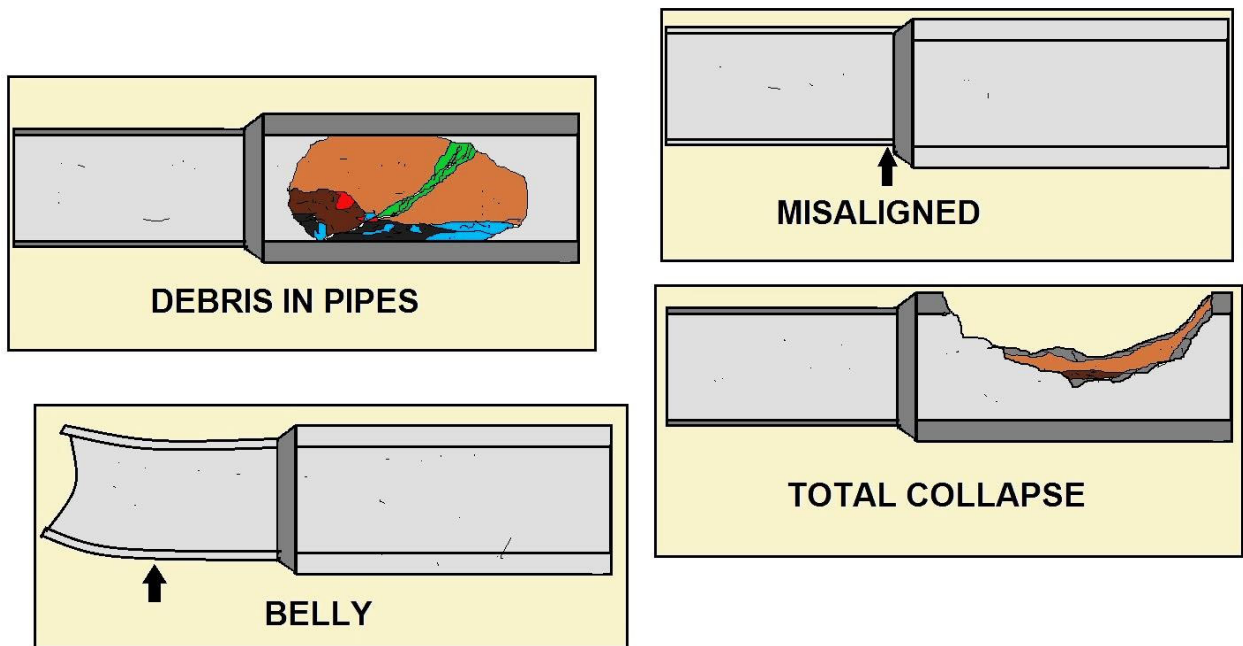

## DAMAGED SEWER PIPE EXAMPLES

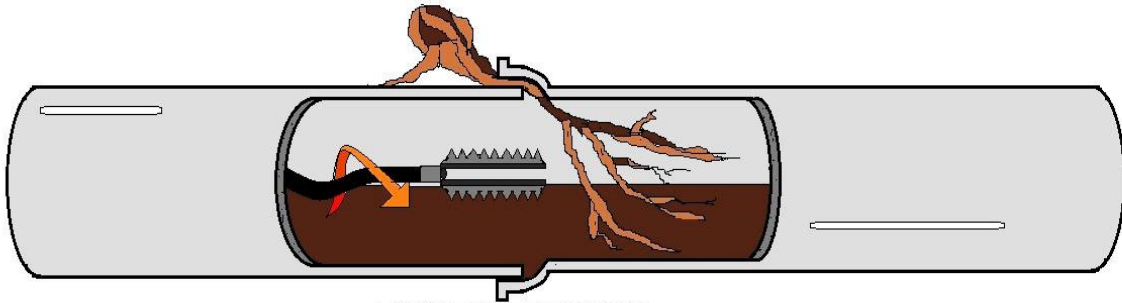

**ROOT INTRUSION**  
(CLEANED WITH A CABLE FITTED WITH A ROOT-CUTTING BLADE)

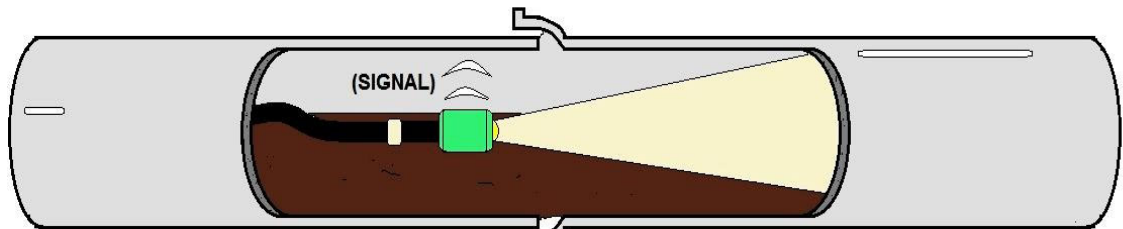

**MIS-ALIGNED / CRACKED PIPE**  
(A CAMERA IS USED TO SHOW THE LOCATION OF THE PROBLEM VIA A SIGNAL)

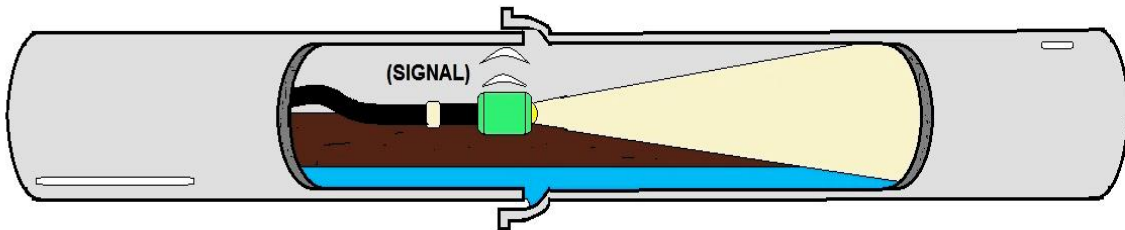

**PIPE WITH A BELLY**  
(A CAMERA IS USED TO SHOW THE LOCATION OF THE PROBLEM VIA A SIGNAL)

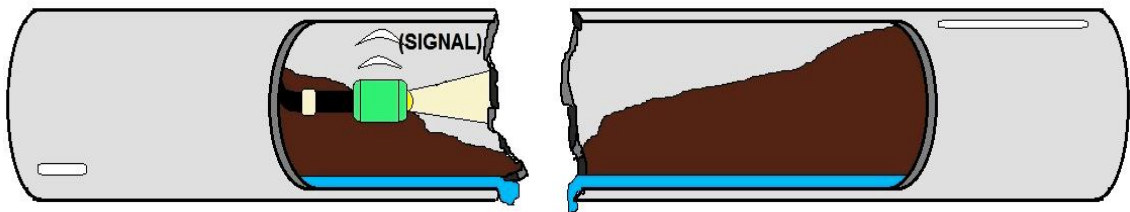

**PIPE THAT HAS BEEN CRUSHED**  
(A CAMERA IS USED TO SHOW THE LOCATION OF THE PROBLEM VIA A SIGNAL)

## MAJOR SEWER PIPE PROBLEM DIAGRAM

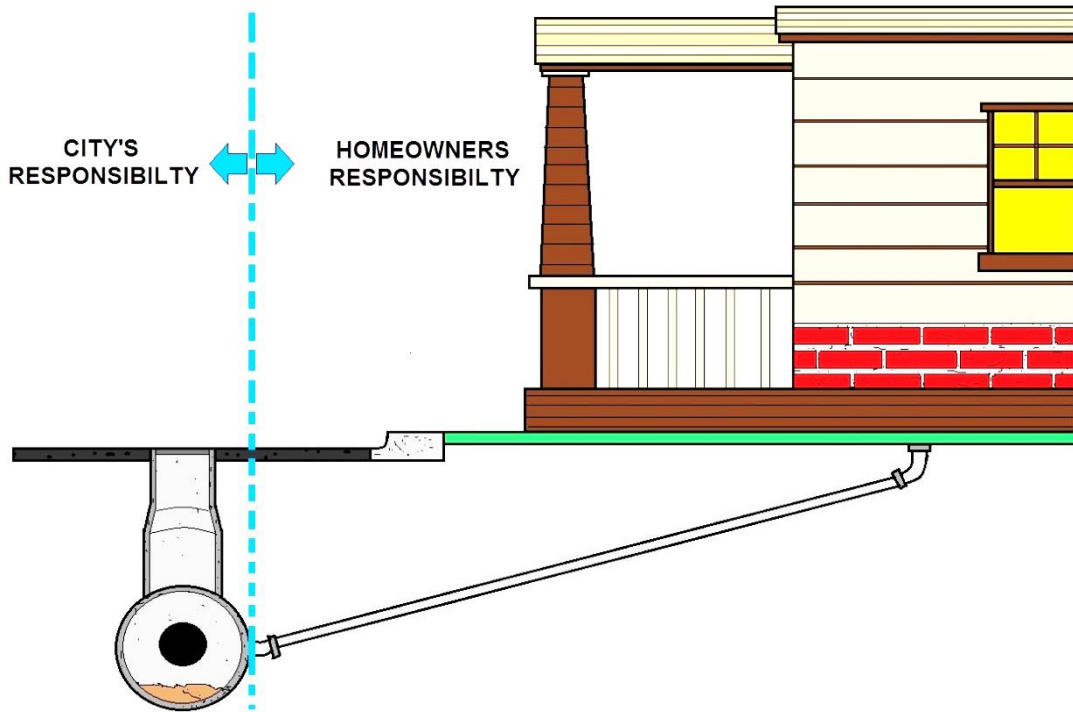

**DESIGNATING SEWER MAINTENANCE RESPONSIBILITY**

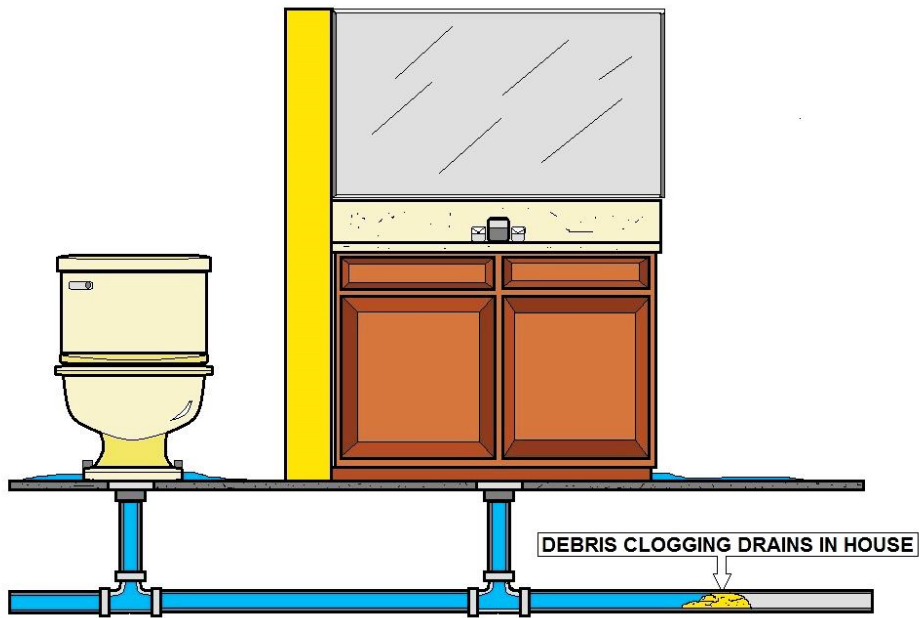

**EXAMPLE OF A CLOGGED SEWER LINE**

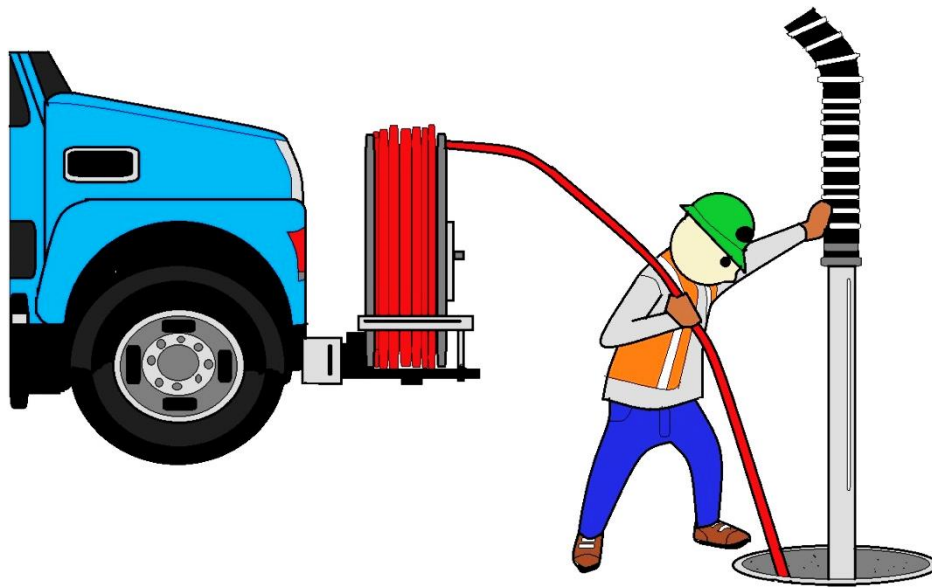

**USING A VACUUM TRUCK TO CLEAN SEWER**

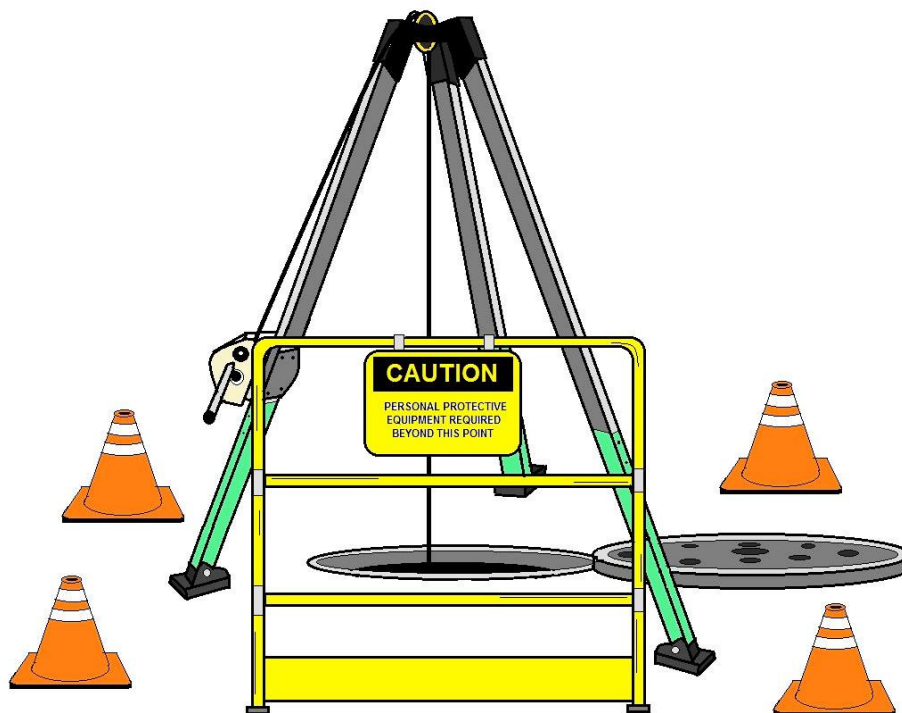

**SAFETY EQUIPMENT TO ENTER A SEWER SAFELY**

## Sewer Technology Uses and Applications Diagrams

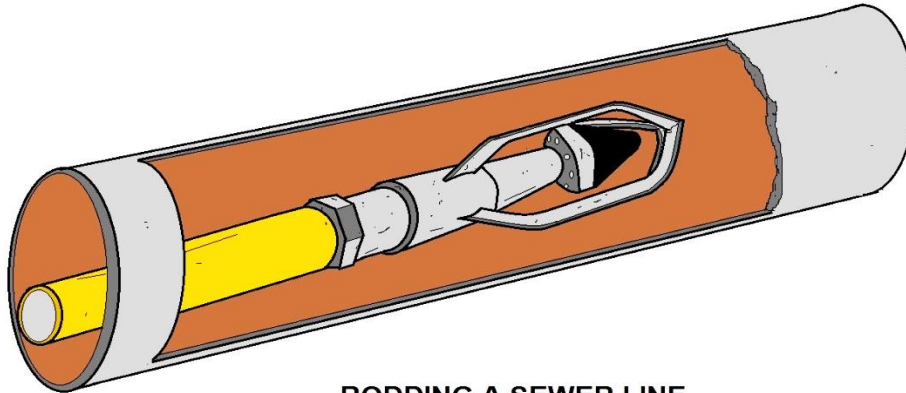

**RODDING A SEWER LINE**

*As a collection system operator, you will need knowledge of many different concerns in order to properly identify the problem and sometimes you'll need to order the remedy, solution or correction.*

### **Mechanical Rodding**

- Uses an engine and a drive unit with continuous rods or sectional rods.
- As blades rotate, they break up grease deposits, cut roots, and loosen debris.
- Rodders also help thread the cables used for TV inspections and bucket machines.
- Most effective in lines up to 12 inches in diameter.

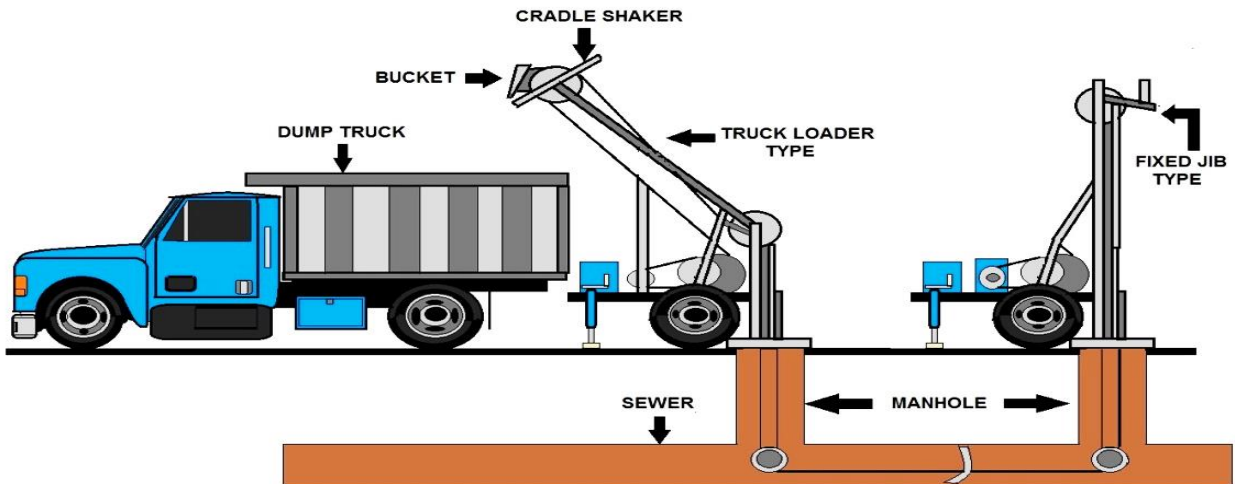

**TRAILER MOUNTED BUCKET MACHINES**

### **Bucket Machine**

- Cylindrical device, closed on one end with 2 opposing hinged jaws at the other.
- Jaws open and scrape off the material and deposit it in the bucket.
- Partially removes large deposits of silt, sand, gravel, and some types of solid waste.

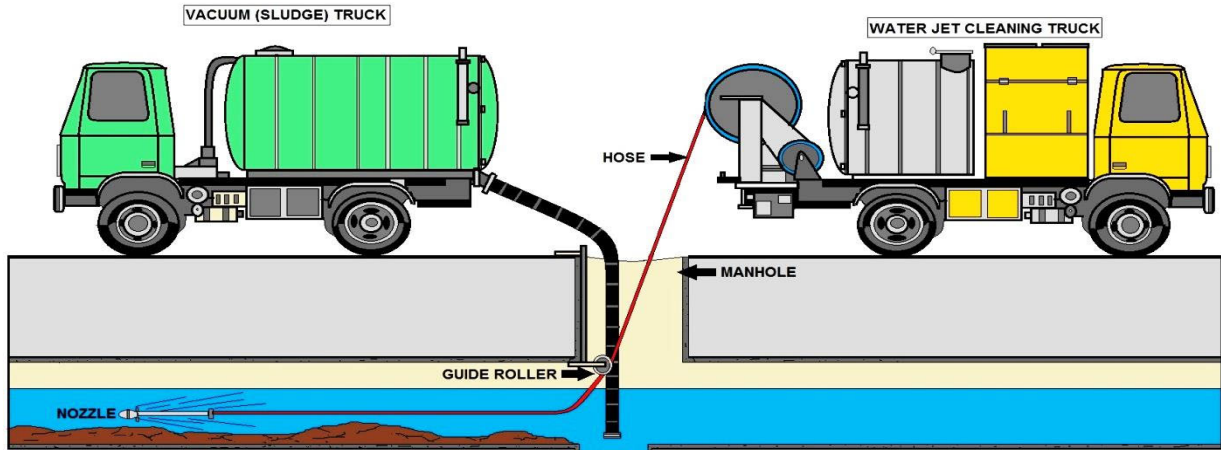

## HYDRAULIC SEWER CLEANING PROCESS

### Hydraulic Balling

- A threaded rubber cleaning ball that spins and scrubs the pipe interior as flow increases in the sewer line.
- Removes deposits of settled inorganic material and grease build-up.
- Most effective in sewers ranging in size from 5-24 inches.

### Flushing

- Introduces a heavy flow of water into the line at a manhole.
- Removes floatables and some sand and grit.
- Most effective when used in combination with other mechanical operations, such as rodding or bucket machine cleaning.

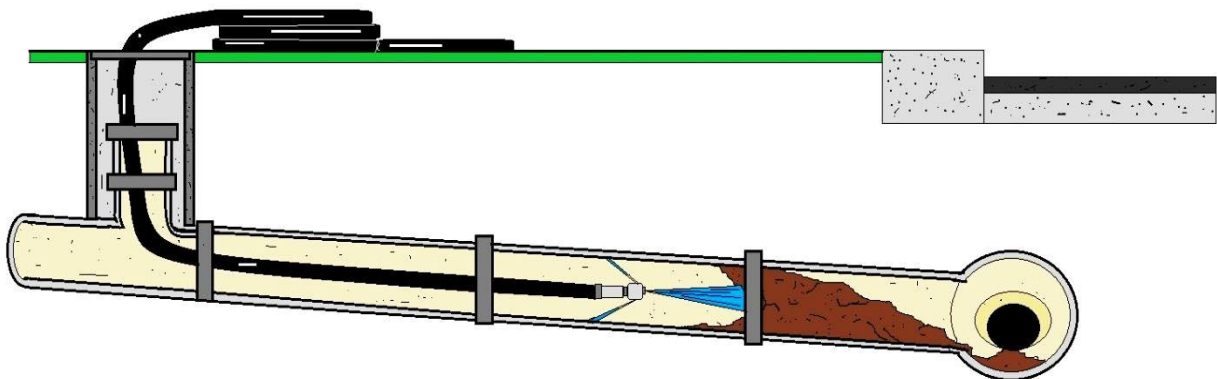

## JETTING A SEWER LINE

### Jetting

- Directs high velocities of water against pipe walls.
- Removes debris and grease build-up, clears blockages, and cuts roots within small diameter pipes.
- Efficient for routine cleaning of small diameter, low flow sewers.



## Sewer Cleaning - Technology Applications Diagrams

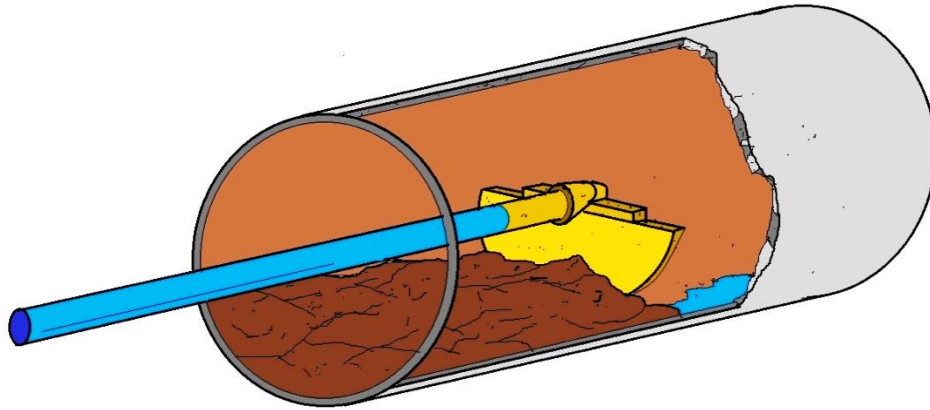

**DROP SCRAPER**

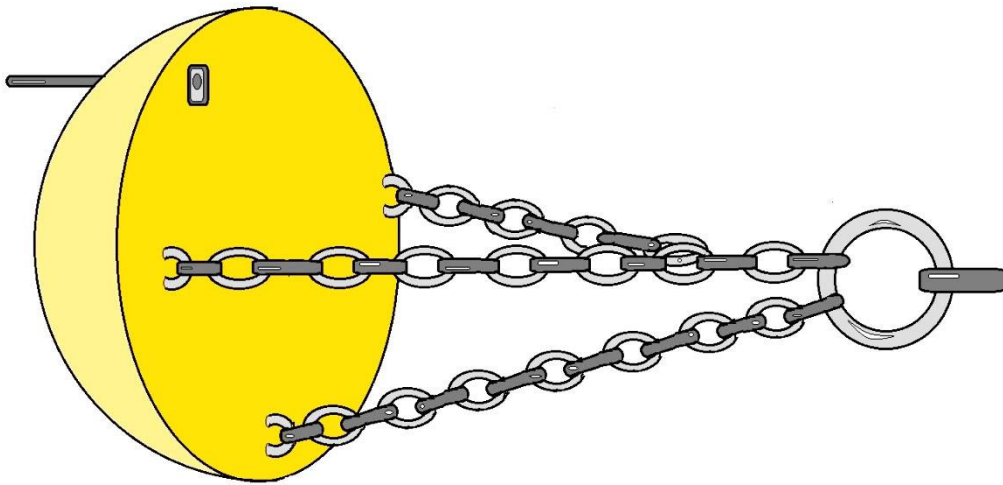

**SEWER SCRAPER**

### **Scooter**

- Round, rubber-rimmed, hinged metal shield that is mounted on a steel framework on small wheels. The shield works as a plug to build a head of water.
- Scours the inner walls of the pipe lines.
- Effective in removing heavy debris and cleaning grease from line.

### **Kites, Bags, and Poly Pigs**

- Similar in function to the ball.
- Rigid rims on bag and kite induce a scouring action.
- Effective in moving accumulations of decayed debris and grease downstream.

### **Silt Traps**

- Collect sediments at convenient locations.
- Must be emptied on a regular basis as part of the maintenance program.

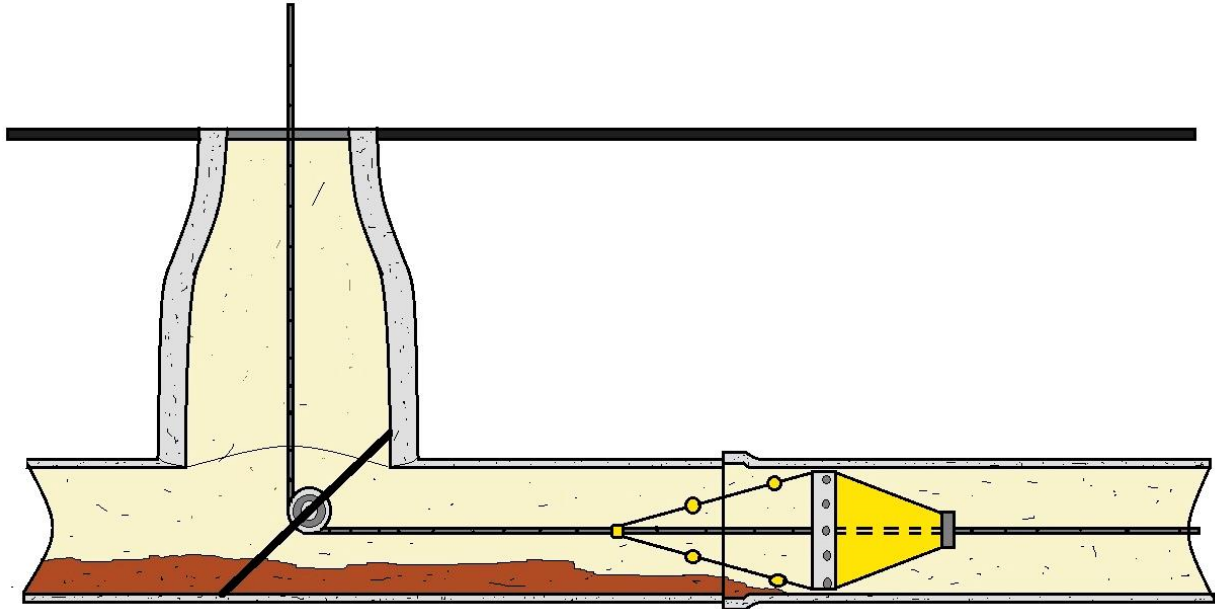

**SEWER KITE DIAGRAM**

### **Grease Traps and Sand/Oil Interceptors**

- The ultimate solution to grease build-up is to trap and remove it.
- These devices are required by some uniform building codes and/or sewer-use ordinances.

Typically sand/oil interceptors are required for automotive business discharge.

- Need to be thoroughly cleaned to function properly.
- Cleaning frequency varies from twice a month to once every 6 months, depending on the amount of grease in the discharge.
- Need to educate restaurant and automobile businesses about the need to maintain these traps.

### **Chemicals**

*Before using these chemicals review the Safety Data Sheets (SDS) and consult the local authorities on the proper use of chemicals as per local ordinance and the proper disposal of the chemicals used in the operation. If assistance or guidance is needed regarding the application of certain chemicals, contact the U.S. EPA or state water pollution control agency.*

- Used to control roots, grease, odors ( $H_2S$  gas), concrete corrosion, rodents and insects.
- *Root Control* - longer lasting effects than power rodder (approximately 2-5 years).
- *$H_2S$  gas* - some common chemicals used are chlorine ( $Cl_2$ ), hydrogen peroxide ( $H_2O_2$ ), pure Oxygen ( $O_2$ ), air, lime ( $Ca(OH)_2$ ), sodium hydroxide ( $NaOH$ ), and iron salts.
- *Grease and soap problems* - some common chemicals used are bioacids, digester, enzymes, bacteria cultures, catalysts, caustics, hydroxides, and neutralizers.

Source: Information provided by Arbour and Kerri, 1997 and Sharon, 1989.

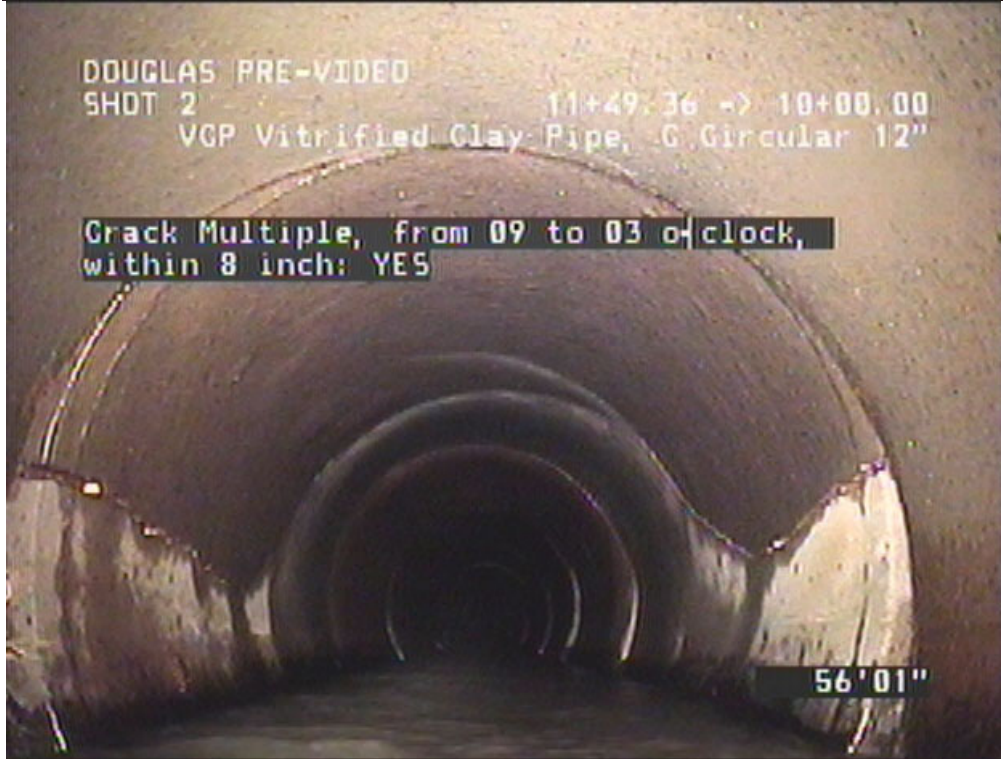

Photographs courtesy of Propipe.

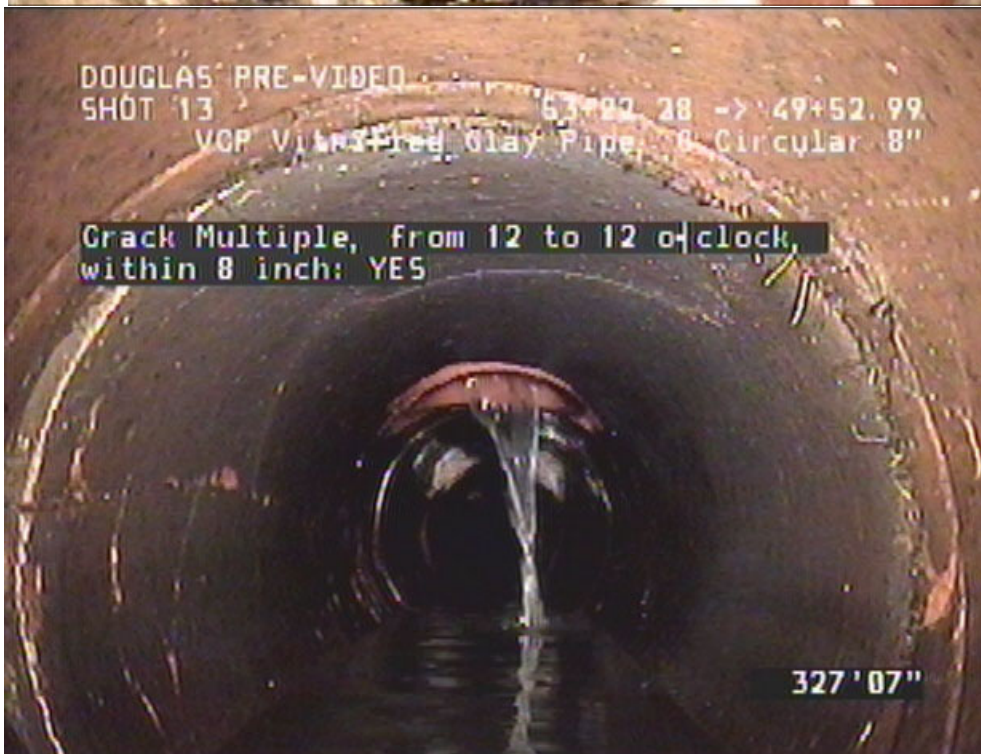

*Photographs courtesy of Propipe.*

## More on Sewer Cleaning Procedures

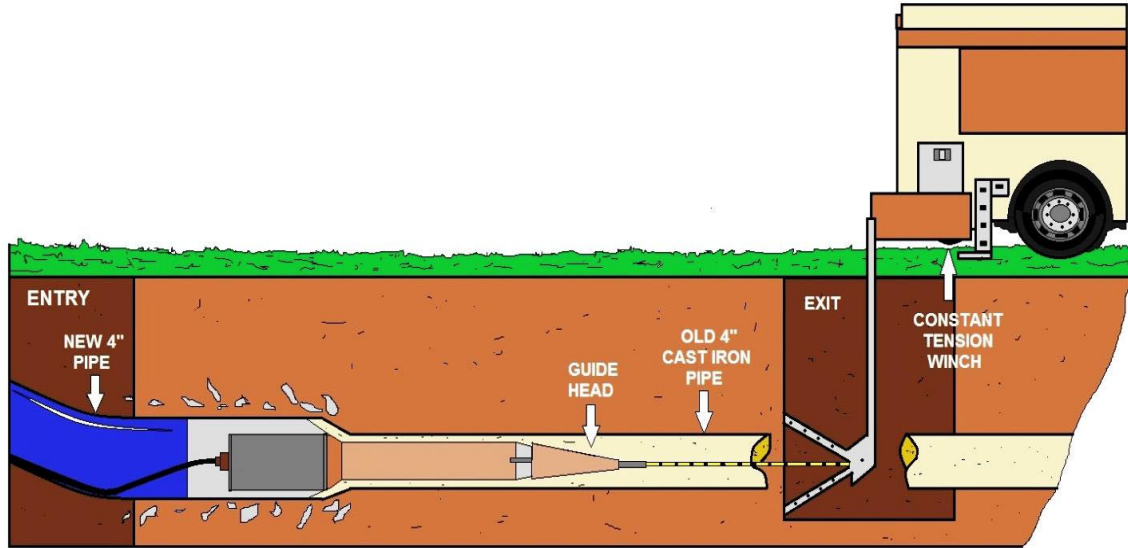

**TRENCHLESS SEWER REPAIR DIAGRAM**

Most cities that take advantage of sewer cleaning procedures are able to determine that as the maintenance frequency increased, there was an increase in system performance. It is recommended for 70 inspections and maintenance activities for every 30 cleanings. Inspections are considered more important because they help define and prevent future problems. A study performed by the American Society of Civil Engineers reports that the most important maintenance activities are cleaning and CCTV inspections. A maintenance plan attempts to develop a strategy and priority for maintaining pipes based on several of the following factors:

- Problems- frequency and location; 80 percent of problems occur in 25 percent of the system (Hardin and Messer, 1997).
- Age- older systems have a greater risk of deterioration than newly constructed sewers.
- Construction material- pipes constructed of materials that are susceptible to corrosion have a greater potential of deterioration and potential collapse. Non-reinforced concrete pipes, brick pipes, and asbestos cement pipes are examples of pipes susceptible to corrosion.
- Pipe diameter/volume conveyed- pipes that carry larger volumes take precedence over pipes that carry a smaller volume.
- Location- pipes located on shallow slopes or in flood prone areas have a higher priority.
- Force main vs. gravity-force mains have a higher priority than gravity, size for size, due to the complexity of the cleaning and repairs.
- Subsurface conditions- depth to groundwater, depth to bedrock, soil properties (classification, strength, porosity, compressibility, frost susceptibility, erodibility, and pH).
- Corrosion potential- Hydrogen Sulfide ( $H_2S$ ) is responsible for corroding sewers, structures, and equipment used in wastewater collection systems. The interior conditions of the pipes need to be monitored and treatment needs to be implemented to prevent the growth of slime bacteria and the production of  $H_2S$  gases.

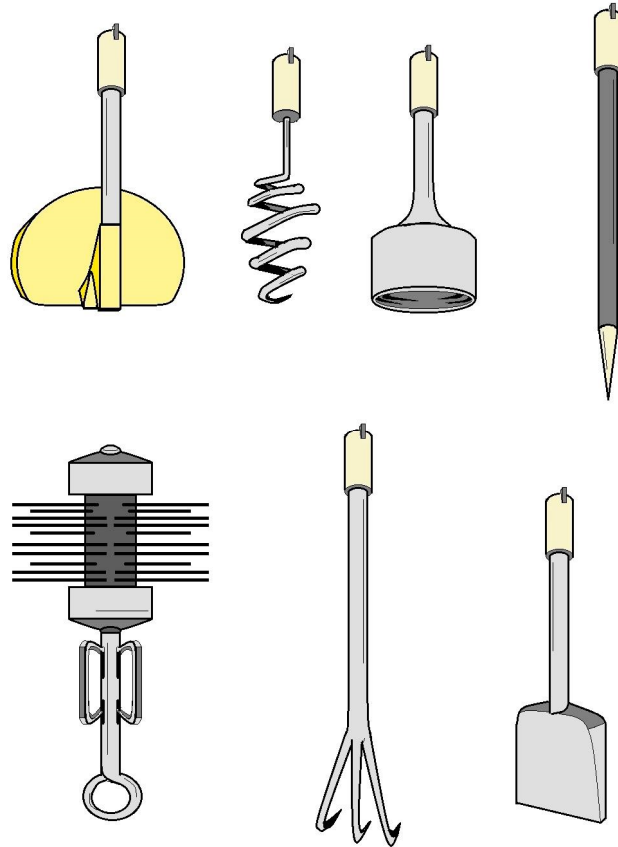

## COMMON SEWER CLEANING TOOLS

### Limitations of Cleaning Methods

- Sewer Cleaning and Stoppage Section- this section responds to customer complaints, pinpoints problems within the lines, and clears all blockages.
- TV Section- this section locates defects and building sewer connections (also referred to as taps) within the system.
- Preventive Maintenance Section- this section cleans and inspects the lines and also provides for Quality Assurance and Quality Control (QA/QC). Most of collection inspections use CCTV system. However, a large percent of the lines in the worst and oldest sections of the system are inspected visually. Visual inspections are also used in the most recently installed lines and manholes.

The collection system will normally utilize a variety of cleaning methods including jetting, high velocity cleaning, rodding, bucket machining, and using stop trucks (sectional rods with an attached motor).

As part of a preventive maintenance approach, most collection system operators also have been using combination trucks with both flush and vacuum systems. To control roots, most collection system operators uses a vapor rooter eradication system which can ensure that no roots return to the line for up to five years. The cleaning and inspection crews will usually consist of two members to operate each of the combination trucks and TV trucks.

## Detailed Cleaning Methods

The purpose of sewer cleaning is to remove foreign material from the sewer and generally is undertaken to alleviate one of the following conditions:

- Blockages (semisolid obstructions resulting in a virtual cessation of flow). These generally are dealt with on an emergency basis, although the underlying cause can be treated preemptively.
- Hydraulic capacity. In some cases, sediment, roots, intrusions (connections or other foreign bodies), grease, encrustation and other foreign material restrict the capacity of a sewer, causing surcharge or flooding. Cleaning the sewer may alleviate these problems permanently, or at least temporarily.
- Pollution caused by either the premature operation of combined wastewater overflows because of downstream restrictions to hydraulic capacity or pollution caused by the washing through and discharge of debris from overflows during storms.
- Odor caused by the retention of solids in the system for long periods resulting in, among other things, wastewater turning septic and producing hydrogen sulfide.
- Sewer inspections, where the sewer needs to be cleaned before inspection. This requirement most often occurs when using in-sewer CCTV inspection techniques.
- Sewer rehabilitation where it is necessary to clean the sewers immediately before the sewer being rehabilitated.

Common cleaning methods include jet rodding, manual rodding, winching or dragging, cutting, and manual or mechanical digging. The method usually is determined in advance and is normally contingent on the pipe type and size and on the conditions expected in the pipe.

### Jet Rodding

This method depends on the ability of high-velocity jets of water to dislodge materials from the pipe walls and transport them down the sewer. Water under high pressure (approximately 2000 psi) is fed through a hose to a nozzle containing a rosette of jets sited so the majority of flow is ejected in the opposite direction of the flow in the hose. These jets propel the hose through the sewer and dislodge the materials on the sewer walls. A range of nozzles is available to cope with the different pipe diameters and materials encountered. The hoses, nozzles, water supply and necessary pumps usually are incorporated in a purpose-built vehicle.

### Rodding

This method is generally a manual push-pull technique used to clear blockages in smaller-diameter, shallow sewer systems typically not exceeding (10 in. in diameter or 6 ft. in depth. For sewer greater than 10 in. in diameter, the rods tend to wander and are not very effective. The distance from the access point is limited to approximately 60 ft.

### Dragging

This is a technique where custom buckets are dragged through the sewer and the material deposited into skips.

### Cutting

This method generally is used for removing roots from sewers. High-pressure water jet cutters have been developed for removing even more solid intrusions, such as intruding

connections. Care is required to eliminate damage to the existing sewer structure.

### **Manual or Mechanical Digging**

Traditionally used in larger-diameter sewers, this method involves manually excavating the material and placing it in buckets for removal. As the sewer system can be hazardous, the technique now is used infrequently. High-pressure jet equipment also can be used manually in larger sewers.

### **Balling, Jetting, Scooter**

In general, these methods are only successful when necessary water pressure or head is maintained without flooding basements or houses at low elevations. Jetting - The main limitation of this technique is that cautions need to be used in areas with basement fixtures and in steep-grade hill areas.

### **Balling**

Balling cannot be used effectively in pipes with bad offset joints or protruding service connections because the ball can become distorted.

### **Scooter**

When cleaning larger lines, the manholes need to be designed to a larger size in order to receive and retrieve the equipment. Otherwise, the scooter needs to be assembled in the manhole. Caution also needs to be used in areas with basement fixtures and in steep-grade hill areas.

### **Bucket Machine**

This device has been known to damage sewers. The bucket machine cannot be used when the line is completely plugged because this prevents the cable from being threaded from one manhole to the next. Set-up of this equipment is time-consuming.

### **Flushing**

This method is not very effective in removing heavy solids. Flushing does not remedy this problem because it only achieves temporary movement of debris from one section to another in the system.

### **High Velocity Cleaner**

The efficiency and effectiveness of removing debris by this method decreases as the cross-sectional areas of the pipe increase. Backups into residences have been known to occur when this method has been used by inexperienced operators. Even experienced operators require extra time to clear pipes of roots and grease.

### **Kite or Bag**

When using this method, use caution in locations with basement fixtures and steep-grade hill areas.

### **Rodding**

Continuous rods are harder to retrieve and repair if broken and they are not useful in lines with a diameter of greater than 300 mm (0.984 feet) because the rods have a tendency to coil and bend. This device also does not effectively remove sand or grit, but may only loosen the material to be flushed out at a later time. Source: U.S. EPA, 1993.



## Sewer – Hydraulic Cleaning Sub-Section

The purpose of sewer cleaning is to remove accumulated material from the sewer. Cleaning helps to prevent blockages and is used to prepare the sewer for inspections. Stoppages in gravity sewers are usually caused by a structural defect, poor design, poor construction, an accumulation of material in the pipe (especially grease), or root intrusion. Protruding traps (lateral sewer connections incorrectly installed so that they protrude into the main sewer) may catch debris, which then causes a further buildup of solids that eventually block the sewer.

### Results of Various Flow Velocities

Velocity Result

- 2.0 ft/sec.....Very little material buildup in pipe.
- 1.4-2.0 ft/sec.....Heavier grit (sand and gravel) begin to accumulate.
- 1.0-1.4 ft/sec.....Inorganic grit and solids accumulate.
- Below 1.0 ft/sec.....Significant amounts of organic and inorganic solids accumulate.
- 1.0 to 1.4 feet per second, grit and solids can accumulate leading to a potential blockage.

### Sewer Cleaning Methods

There are three major methods of sewer cleaning: hydraulic, mechanical, and chemical.

Hydraulic cleaning (also referred to as flushing) refers to any application of water to clean the pipe. Mechanical cleaning uses physical devices to scrape, cut, or pull material from the sewer.

Chemical cleaning can facilitate the control of odors, grease buildup, root growth, corrosion, and insect and rodent infestation.

### Sewer Cleaning Records

The backbone of an effective sewer cleaning program is accurate recordkeeping. Accurate recordkeeping provides the collection system owner or operator with information on the areas cleaned. Typical information includes

- Date, time, and location of stoppage or routine cleaning activity
- Method of cleaning used
- Identity of cleaning crew
- Cause of stoppage
- Further actions necessary and/or initiated
- Weather conditions

The owner or operator should be able to identify problem collection system areas, preferably on a map. Potential problem areas identified should include those due to grease or industrial discharges, hydraulic bottlenecks in the collection system, areas of poor design (e.g., insufficiently sloped sewers), areas prone to root intrusion, sags, and displacements. The connection between problem areas in the collection system and the preventive maintenance cleaning schedule should be clear.

The owner or operator should also be able to identify the number of stoppages experienced per mile of sewer pipe. If the system is experiencing a steady increase in stoppages, the reviewer should try to determine the cause (i.e., lack of preventive maintenance funding, deterioration of the sewers due to age, an increase in grease producing activities, etc.).

## **Parts and Equipment Inventory**

An inventory of spare parts, equipment, and supplies should be maintained by the collection system owner or operator. The inventory should be based on the equipment manufacturer's recommendations, supplemented by historical experience with maintenance and equipment problems. Without such an inventory, the collection system may experience long down times or periods of inefficient operation in the event of a breakdown or malfunction. Files should be maintained on all pieces of equipment and major tools. The owner or operator should have a system to assure that each crewmember has adequate and correct tools for the job.

The owner or operator should maintain a yard where equipment, supplies, and spare parts are maintained and personnel are dispatched. Very large systems may maintain more than one yard. In this case, the reviewer should perform a visual survey at the main yard. In small to medium size systems, collection system operations may share the yard with the department of public works, water department, or other municipal agencies. In this case, the reviewer should determine what percentage is being allotted for collection system items. The most important features of the yard are convenience and accessibility.

The reviewer should observe a random sampling of inspection and maintenance crew vehicles for equipment as described above. A review of the equipment and manufacturer's manuals aids will determine what spare parts should be maintained.

The owner or operator should then consider the frequency of usage of the part, how critical the part is, and finally, how difficult the part is to obtain when determining how many of the part to keep in stock. Spare parts should be kept in a clean, well-protected stock room.

## **Owner or Operator - Point to Note**

The owner or operator should have a procedure for determining which spare parts are critical for the proper operation of the collection system. Similar to equipment and tools management, a tracking system should be in place, including Guide for Evaluating CMOM Programs at Sanitary Sewer Collection Systems procedures on logging out materials, and when maintenance personnel must use them.

The owner or operator should be able to produce the spare parts inventory and clearly identify those parts deemed critical. The reviewer should evaluate the inventory and selected items in the stockroom to determine whether the specified numbers of these parts are being maintained.



## **Sewer Maintenance - Advantages and Disadvantages**

The primary benefit of implementing a sewer maintenance program is the reduction of SSOs, basement backups, and other releases of wastewater from the collection system due to substandard sewer conditions. Improper handling of instruments and chemicals used in inspecting and maintaining sewer lines may cause environmental harm.

### **Examples include:**

- Improperly disposing of collected materials and chemicals from cleaning operations.
- Improperly handling chemical powdered dyes.
- Inadequately maintaining inspection devices.

### **Visual Inspection**

In smaller sewers, the scope of problems detected is minimal because the only portion of the sewer that can be seen in detail is near the manhole. Therefore, any definitive information on cracks or other structural problems is unlikely. However, this method does provide information needed to make decisions on rehabilitation.

### **Camera Inspection**

When performing a camera inspection in a large diameter sewer, the inspection crew is essentially taking photographs haphazardly, and as a result, the photographs tend to be less comprehensive.

### **Closed Circuit Television (CCTV)**

This method requires late night inspection and as a result the TV operators are vulnerable to lapses in concentration. CCTV inspections are also expensive and time consuming. The video camera does not fit into the pipe and during the inspection it remains only in the maintenance hole.

### **Lamping Inspection**

As a result, only the first 10 feet of the pipe can be viewed or inspected using this method. Source: Water Pollution Control Federation, 1989. Some instruments have a tendency to become coated with petroleum based residues and if not handled properly they can become a fire hazard. The following case study provide additional case study data for sewer cleaning methods.

### **Fairfax County, Virginia**

The Fairfax County Sanitary Sewer System comprises over 3000 miles of sewer lines. As is the case with its sewer rehabilitation program, the county's sewer maintenance program also focuses on inspection and cleaning of sanitary sewers, especially in older areas of the system. Reorganization and streamlining of the sewer maintenance program, coupled with a renewed emphasis on increasing productivity, has resulted in very significant reductions in sewer backups and overflows during the past few years.

1998, there were a total of 49 such incidents including 25 sewer backups and 24 sewer overflows. The sewer maintenance program consists of visual inspections, scheduled sewer cleanings based on maintenance history, unscheduled sewer cleanings as determined by visual or closed circuit television inspections, and follow-up practices to determine the cause of backups and overflows.

Visual inspections are carried out by using a mirror attached to a pole; however, use of portable cameras has been recently introduced to enhance the effectiveness of visual inspections.

Older areas of the sewer system are inspected every two years; whereas, the inspection of relatively new areas may be completed in 3 to 4 years. Cleaning is an important part of pipe maintenance.

Sewer line cleaning is prioritized based on the age of the pipe and the frequency of the problems within it. The county uses rodding and pressurized cleaning methods to maintain the pipes.

Bucket machines are rarely used because cleaning by this method tends to be time consuming. Many cities use mechanical, rather than chemical, methods to remove grease and roots. Introducing chemicals into the cleaning program may require hiring an expert crew, adopting a new program, and instituting a detention time to ensure the chemicals' effectiveness.

Record keeping is also vital to the success of such a maintenance program. The county has started tracking the number of times their sewer lines were inspected and cleaned and the number of overflows and backups a sewer line experienced. This information has helped the county re-prioritize sewer line maintenance and adapt a more appropriate time schedule for cleaning and inspecting the sewer lines.

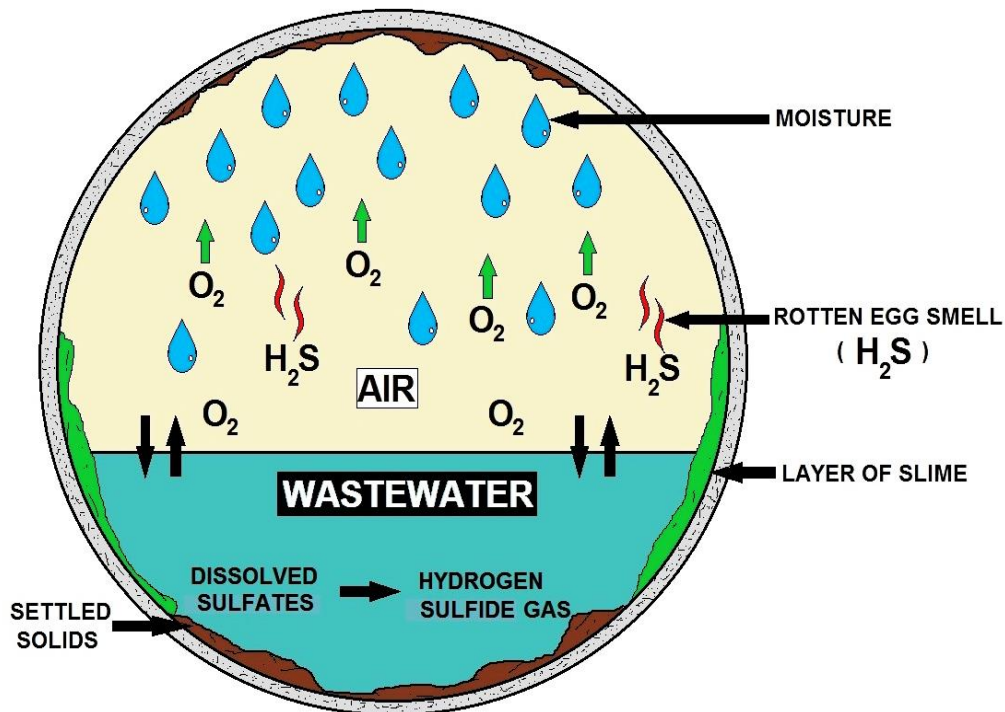

### HOW CORROSION FORMS IN SEWER PIPING

## Sewer System Rehabilitation Sub-Section

The collection system owner or operator should have a sewer rehabilitation program. The objective of sewer rehabilitation is to maintain the overall viability of a collection system. This is done in three ways:

- (1) ensuring its structural integrity;
- (2) limiting the loss of conveyance and wastewater treatment capacity due to excessive I/I; and
- (3) limiting the potential for groundwater contamination by controlling exfiltration from the pipe network.

The rehabilitation program should build on information obtained as a result of all forms of maintenance and observations made as part of the capacity evaluation and asset inventory to assure the continued ability of the system to provide sales and service at the least cost. The reviewer should try to gain a sense of how rehabilitation is prioritized. Priorities may be stated in the written program or may be determined through interviews with system personnel.

There are many rehabilitation methods; the choice of methods depends on pipe size, type, location, dimensional changes, sewer flow, material deposition, surface conditions, severity of I/I, and other physical factors. Non-structural repairs typically involve the sealing of leaking joints in otherwise sound pipe.

Structural repairs involve either the replacement of all or a portion of a sewer line, or the lining of the sewer. These repairs can be carried out by excavating, usually for repairs limited to one or two pipe segments (these are known as point repairs) or by trenchless technologies (in which repair is carried out via existing manholes or a limited number of access excavations).

The rehabilitation program should identify the methods that have been used in the past, their success rating, and methods to be used in the future. A reviewer who wants further guidance on methods of rehabilitation may consult the owner's or operator's policies regarding service lateral rehabilitation, since service laterals can constitute a serious source of I/I.

Manholes should not be neglected in the rehabilitation program. Manhole covers can allow significant inflow to enter the system because they are often located in the path of surface runoff.

Manholes themselves can also be a significant source of infiltration from cracks in the barrel of the manhole. The owner or operator should be able to produce documentation on the location and methods used for sewer rehabilitation. The reviewer should compare the rehabilitation accomplished with that recommended by the capacity evaluation program.

When examining the collection system rehabilitation program, the reviewer should be able to answer the following questions:

- Is rehabilitation taking place before it becomes emergency maintenance?
- Are recommendations made as a result of the previously described inspections?
- Does the rehabilitation program take into account the age and condition of the sewers?



The sewer vacuum truck utilizes both a high pressure stream of water and a vacuum system to clean and remove built up debris from sewer lines. These versatile vehicles are also used to clean lift station wet wells, stormwater catch basins, and to perform excavations to locate broken water or sewer lines. It reduces repair times and costs by over 50%.

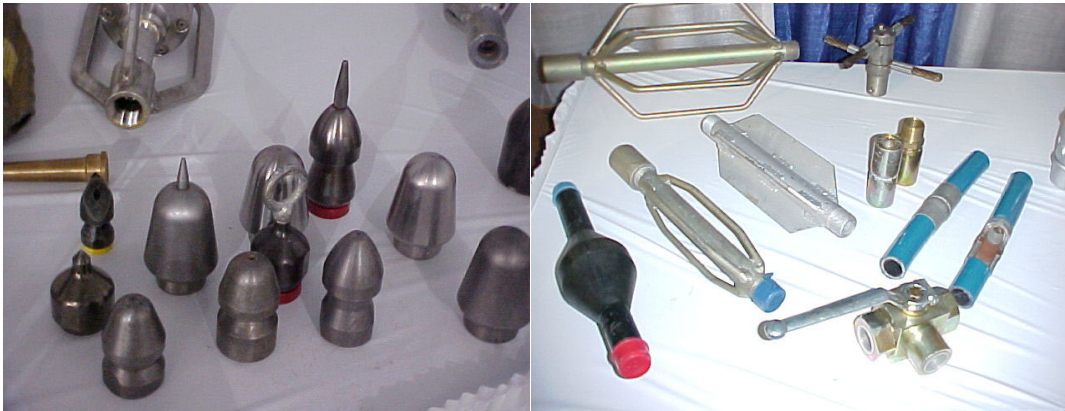

Above, various Jetter or hydraulic cleaning attachments.



Root intrusion

## Tree Roots vs. Sanitary Sewer Lines

### Root Growth in Pipes

Roots require oxygen to grow, they do not grow in pipes that are full of water or where high ground water conditions prevail. Roots thrive in the warm, moist, nutrient rich atmosphere above the water surface inside sanitary sewers. The flow of warm water inside the sanitary sewer service pipe causes water vapor to escape to the cold soil surrounding the pipe. Tree roots are attracted to the water vapor leaving the pipe and they follow the vapor trail to the source of the moisture, which are usually cracks or loose joints in the sewer pipe. Upon reaching the crack or pipe



joint, tree roots will penetrate the opening to reach the nutrients and moisture inside the pipe.

This phenomenon continues in winter even though trees appear to be dormant.

### Problems Caused by Roots Inside Sewers

Once inside the pipe, roots will continue to grow, and if not disturbed, they will completely fill the pipe with multiple hair-like root masses at each point of entry. The root mass inside the pipe becomes matted with grease, tissue paper, and other debris discharged from the residence or business. Homeowners will notice the first signs of a slow flowing drainage system by hearing gurgling noises from toilet bowls and observing wet areas around floor drains after completing the laundry. A complete blockage will occur if no remedial action is taken to remove the roots/blockage. As roots continue to grow, they expand and exert considerable pressure at the crack or joint where they entered the pipe. The force exerted by the root growth will break the pipe and may result in total collapse of the pipe. Severe root intrusion and pipes that are structurally damaged will require replacement.

### Tree Roots in Sewer

Tree roots growing inside sewer pipes are generally the most expensive sewer maintenance item experienced by City residents. Roots from trees growing on private property and on parkways throughout the City are responsible for many of the sanitary sewer service backups and damaged sewer pipes.

Homeowners should be aware of the location of their sewer service and refrain from planting certain types of trees and hedges near the sewer lines. The replacement cost of a sanitary sewer service line as a result of damage from tree roots may be very expensive.

### Pipes Susceptible to Root Damage

Some pipe material is more resistant to root intrusion than others are. Clay tile pipe that was commonly installed by developers and private contractors until the late 1980's is easily penetrated and damaged by tree roots. Concrete pipe and PVC pipe may also allow root intrusions, but to a lesser extent than clay tile pipe. PVC pipe is more resistant to root intrusion because it usually has fewer joints. The tightly fitting PVC joints are less likely to leak as a result of settlement of backfill around the pipe.

### Root Spread

During drought conditions and in winter, tree roots travel long distances in search of moisture. As a general rule, tree roots will extend up to 2.5 times the height of the tree, and some species of trees may have roots extending five to seven times the height of the tree.

## Root Growth Control

The common method of removing roots from sanitary sewer service pipes involves the use of augers, root saws, and high pressure flushers. These tools are useful in releasing blockages in an emergency, however, cutting and tearing of roots encourages new growth. The effect is the same as pruning a hedge to promote faster, thicker, and stronger regrowth.

Roots removed by auguring are normally just a small fraction of the roots inside the pipe. To augment the cutting and auguring methods, there are products available commercially that will kill the roots inside the pipe without harming the tree. The use of products such as copper sulfate and sodium hydroxide are not recommended because of negative environmental impacts on the downstream receiving water. Also, these products may kill the roots but they do not inhibit regrowth.

The more modern method used throughout Canada and the United States for controlling root growth involves the use of an herbicide mixed with water and a foaming agent. The foam mixture is pumped into the sewer pipe to kill any roots that come into contact with the mixture. New root growth will be inhibited from three to five years after the treatment, according to the manufacturers.

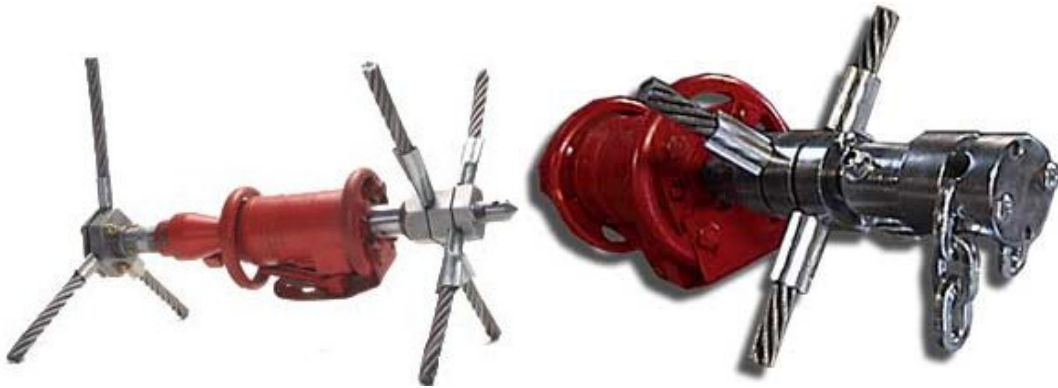

FlexKid is an accessory for Ripper tools designed to clear roots and other blockages from sewer pipes. The unit readily passes through pipes and around or over typical obstructions like offset joints, hand taps and debris. Available for pipes 18 inches and larger, it features durable cable and easy attachment to the rear of any root-cutting motor. It is designed for quick setup and quick size changes in field. No underground (in-manhole) assembly is required, and no manhole modification is necessary.

The Knocker is a chain cleaner designed to use in conjunction with The Ripper. The Ripper positions The Knocker's chain-knocking action in the center of the pipe and keeps the chain from hanging up on offsets and hand-taps. The Ripper follows up by removing loose debris - leaving pipes cleaner than any other sewer cleaning tool - period.

**Courtesy of DML, LLC**  
419 Colford Avenue  
West Chicago, IL 60185  
Phone (630) 293-3653  
rootripper@ameritech.net



## Smoking out Sewer Leaks

*An overview of smoke testing, an important part of successful I & I studies.*

*By Paul Tashian, Superior Signal Company, Inc.*

Used extensively for over 40 years, smoke testing has proven to be a vital ingredient of successful inflow and infiltration (I&I) studies. It is as important now as it has ever been, as growing municipalities increase demands on aging, often deteriorating collection systems. In addition, programs such as the EPA's new CMOM (capacity, management, operations, and maintenance) emphasize a focus on proactive, preventive maintenance practices. Smoke testing is an effective method of documenting sources of inflow and should be part of any CMOM program.

Just as a doctor would require the aid of several instruments to evaluate the status of one's health, various test methods should be used in performing a complete sanitary sewer evaluation survey (SSES). In addition to smoke testing, these could include dyed water testing, manhole inspection, TV inspection, flow monitoring, and more. Specializing in sanitary sewer evaluation surveys, Wade & Associates of Lawrence Kansas states a reduction of 30 to 50% in peak flows can be expected as a result of implementing these types of programs.

Smoke testing is a relatively simple process, which consists of blowing smoke mixed with larger volumes of air into the sanitary sewer line, usually induced through the manhole.

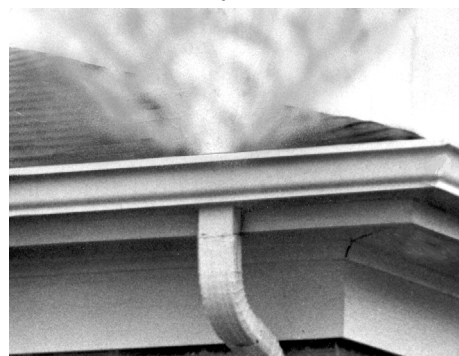

The smoke travels the path of least resistance and quickly shows up at sites that allow surface water inflow. Smoke will identify broken manholes, illegal connections (including roof drains, sump pumps, yard drains and more), uncapped lines, and will even show cracked mains and laterals providing there is a passageway for the smoke to travel to the surface.

Although video inspection and other techniques are certainly important components of an I&I survey, research has shown that approximately 65% of all extraneous stormwater inflow enters the system from somewhere other than the main line. Smoke testing is an excellent method of inspecting both the mainlines, laterals and more. Smoke travels throughout the system, identifying problems in all connected lines, even sections of line that were not known to exist, or thought to be independent or unconnected. Best results are obtained during dry weather, which allows smoke better opportunity to travel to the surface.

### Necessary Equipment

**Blowers;** Most engineering specifications for smoke testing identify the use of a blower able to provide 1750 cfm (cubic feet of air per minute), however in today's world it seems to be the mindset that bigger is better. New smoke blowers on the market can deliver over 3000 cfm, but is this really needed? Once the manhole area is filled, the smoke only needs to travel sections of generally 8 or 10-inch pipe.

Moving the air very quickly is useless if the blower does not have the static pressure to push that air/smoke through the lines. If you've used high CFM blowers and found that smoke frequently backs up to the surface, this may be your problem.

## Blowers

There are two types of blowers available for smoke testing sewers: squirrel cage and direct drive propeller. In general, squirrel cage blowers are usually larger in size, but can provide more static pressure in relation to CFM.

The output of the squirrel cage type is usually adjustable by alternating pulleys and belts to meet the demands of the job. Propeller style blowers are usually more compact and generally offer approx. 3,200 CFM.

Other than reducing the engine throttle, the output is not adjustable since the fan blade is attached directly to the engine shaft. If purchasing a smoke blower you should ask the manufacturer if the CFM and static pressure output they are quoting is the specification of the propeller itself (uninstalled/free air), or if it is the actual performance when installed in the blower assembly. These two numbers can vary significantly.

## Smoke Types

There are two types of smoke currently offered for smoke testing sewers, classic smoke candles and smoke fluids.

Smoke candles were first used for testing sewers when the process began its popularity back in 1961, and continue to be the most widely used. They are used by simply placing a smoke candle on the fresh air intake side of the blower. Once ignited, the exiting smoke is drawn in with the fresh air and blown down into the manhole and throughout the system.

Smoke candles are available in various sizes that can be used singularly or in combination to meet any need. This type of smoke is formed by a chemical reaction, creating a smoke which contains a high content of atmospheric moisture. It is very visible even at low concentrations, and extremely effective at finding leaks.

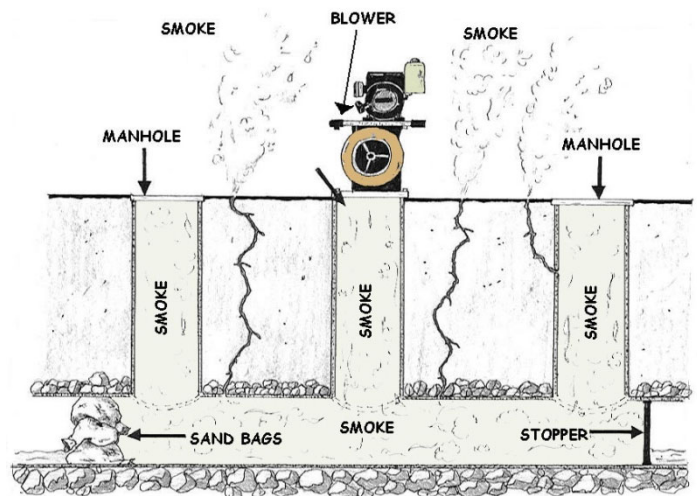

Another available source of smoke is a smoke fluid system. Although they have just recently been more aggressively marketed, smoke fluids became available for sewer testing shortly after smoke candles, some 30 years ago. They can certainly be used effectively, but it is important to understand how they work. This system involves injecting a smoke fluid (usually a petroleum based product) into the hot exhaust stream of the engine where it is heated within the muffler (or heating chamber) and exhausted into the air intake side of the blower. One gallon of smoke fluid is generally less expensive than one dozen smoke candles; however smoke fluids do not consistently provide the same quality of smoke.

When using smoke fluid, it is important to understand that as fluid is injected into the heating chamber (or muffler) it immediately begins to cool the unit. The heating chamber will eventually reach a point where it is not hot enough to completely convert all the fluid to smoke, thus creating thin/wet smoke. This can actually happen quickly, depending on the rate of fluid flow. If the smoke has become thin it can be especially difficult to see at greater distances.

Blocking off sections of line is usually a good idea with any type of smoke, but becomes almost a necessity when using smoke fluid.

Some manufactures have taken steps to address this issue, and now offer better flow control, fluid distribution, and most importantly *insulated heating chambers* to help maintain necessary temperatures.

### **Safety**

Maybe one of the more talked about, yet least understood aspects of smoke testing is the use and safety of these products. As manufacturers have become more competitive, some marketing programs and advertisements have implied danger in the use of competitive types of smoke products. Laboratory reports, scientific studies, and even Material Safety Data Sheets can be quite confusing to most of us who are not trained or qualified to make scientific judgments on this data. Having this information delivered to us in the form of advertising can be dangerous, as most of us tend to believe what we read.

An author of an associated industry publication once stated... "*Do not use smoke bombs, as they give off a toxic gas*". Although the author quotes no scientific literature to support this statement, competitive propaganda has made such implications. It is interesting to note that the same exact statement could be made for smoke fluids. Smoke from fluid is created in the exhaust system of the engine, which contains carbon monoxide. Is carbon monoxide not a toxic gas?

Other statements that have been made include warnings to wear a respirator while smoke testing. While certain manufacturers have issued this warning about competitive products, they do not qualify the statement, nor do they mention the fact that the same thing could be said of their own product. The fact is that a respirator should be worn whenever a person would be exposed to ANY substance in quantities that exceeded OSHA limits. The bottom line on safety is that it is important to use common sense.

All smokes, candles, and fluids can be used safely and effectively when used as directed. When planning to smoke test, it is important to develop a proactive public notice program. Ads in local papers, door hangers, mailers, as well as door to door inquiries are recommended. It is helpful to educate the public as to why the test is being performed and the positive benefits to the community. In addition, it should instruct residents on what to do and who to call if smoke should enter their homes.

It is also important to notify local police and fire departments daily, as to where and when smoke testing will be taking place. Reducing stormwater inflow into collection systems means reduced chances of overflows, less emergency maintenance and less money spent on treatment. If these are goals of your organization, consider smoke testing as a fairly easy, inexpensive, and effective way of achieving your objectives.

*Paul Tashian is employed by Superior Signal Company Inc., a manufacturer of all types of smoke testing equipment, and a major contributor to the original development of smoke testing practices. Paul can be reached at (732) 251-0800, or [ptashian@superiorsignal.com](mailto:ptashian@superiorsignal.com).*

*Also, thanks to Wade & Associates (a company specializing in sanitary sewer evaluation surveys) for offering reference material, and providing artwork and photographs used in this article. For information on Wade's services call (785) 841-1774, or visit [www.wadeinc.com](http://www.wadeinc.com).*

## Operation and Maintenance Summary

Maintaining wastewater collection infrastructure – pump stations, force mains, and sewers – is an integral component of the proper management of a treatment system and critical to preventing illegal wastewater releases. Effective preventive maintenance programs have been shown to significantly reduce the frequency and volume of untreated sewage discharges, help communities plan for the future and save money on emergency response.

The compelling reason to perform a condition assessment of your collection system is to preserve the existing valuable infrastructure, minimize O&M and avoid emergencies and unexpected costs. Condition assessment of your collection system is an investment in managing risk. Knowing the structural condition of your underground assets will allow you to avoid emergencies, prioritize repair and replacement projects, and plan for the future. In a condition assessment, data and information are gathered through observation, direct inspection, investigation, and monitoring.

### Written Protocol

An analysis of the data and information helps determine the structural, operational, and performance status of capital infrastructure assets. A good written protocol, consistently applied, will help define the assessment. Use new data collection techniques to get the most out of your program. Implementing a pro-active program based on information and systematic assessment removes some of the politics and second-guessing from decision-making.

Performing a condition assessment has a cost, but prioritizing work by focusing on critical assets and the maintenance and replacement needs for your collection system is an essential step toward better management.

### Condition Assessments

Maintenance issues are the leading cause of backups and overflows of collection systems. Condition assessment helps utilities discover maintenance and capacity issues before they become maintenance problems. Knowing how your collection system really works will identify Trouble Spots and lead to preventive maintenance decisions, rather than being reactive to the consequences of emergency incidents.

Implementing a pro-active program based on information and systematic assessment provides a manager with the tools to improve decision-making and solid information on which to base staffing and funding decisions.

- grease
- roots
- debris

### Record Keeping

Record keeping of sewer maintenance, inspections and repairs meets several needs of the sewer system. Records help simplify and improve work planning and scheduling, including integrating recurring and on-demand work. Measuring and tracking of workforce productivity and developing unit costs for various activities are a few of the record keeping benefits. Records of sewer maintenance, service line maintenance, and sewer main and service line repairs should be kept and maintained. Examples of record forms are found herein.

## Operations and Maintenance Post Quiz

1. The system's goal should be a minimum of cleaning between \_\_\_\_\_% of the sewers every year.

### Sewer Cleaning and Inspection

2. As sewer system networks age, the risk of deterioration, this \_\_\_\_\_, and collapses becomes a major concern.

3. \_\_\_\_\_ are essential to maintaining a properly functioning system; these activities further a community's reinvestment into its wastewater infrastructure.

### Identify the Cleaning Method

4. Directs high velocities of water against pipe walls. Removes debris and grease build-up, clears blockages, and cuts roots within small diameter pipes. Efficient for routine cleaning of small diameter, low flow sewers.

5. Round, rubber-rimmed, hinged metal shield that is mounted on a steel framework on small wheels. The shield works as a plug to build a head of water. Scours the inner walls of the pipe lines. Effective in removing heavy debris and cleaning grease from line.

6. Similar in function to the ball. Rigid rims on bag and kite induce a scouring action. Effective in moving accumulations of decayed debris and grease downstream.

7. Most effective in lines up to 12 inches in diameter. Uses an engine and a drive unit with continuous rods or sectional rods. As blades rotate, they break up grease deposits, cut roots, and loosen debris.

8. Partially removes large deposits of silt, sand, gravel, and some types of solid waste. Cylindrical device, closed on one end with 2 opposing hinged jaws at the other. Jaws open and scrape off the material and deposit it in the bucket.

9. A threaded rubber cleaning ball that spins and scrubs the pipe interior as flow increases in the sewer line. Removes deposits of settled inorganic material and grease build-up. Most effective in sewers ranging in size from 5-24 inches.

10. Introduces a heavy flow of water into the line at a manhole. Removes floatables and some sand and grit. Most effective when used in combination with other mechanical operations, such as rodding or bucket machine cleaning.

### More on Sewer Cleaning Procedures

A maintenance plan attempts to develop a strategy and priority for maintaining pipes based on several of the following factors:

11. \_\_\_\_\_ - frequency and location; 80 percent of problems occur in 25 percent of the system.

12. Force main vs. gravity-force mains have a higher priority than gravity, size for size, due to the complexity of the \_\_\_\_\_.

13. \_\_\_\_\_ - Hydrogen Sulfide (H<sub>2</sub>S) is responsible for corroding sewers, structures, and equipment used in wastewater collection systems. The interior conditions of the pipes need to be monitored and treatment needs to be implemented to prevent the growth of slime bacteria and the production of H<sub>2</sub>S gases.

14. \_\_\_\_\_ - pipes that carry larger volumes take precedence over pipes that carry a smaller volume.

### Limitations of Cleaning Methods

15. \_\_\_\_\_ will normally utilize a variety of cleaning methods including jetting, high velocity cleaning, rodding, bucket machining, and using stop trucks.

16. The cleaning and inspection crews will usually consist of two members to operate each of the?

### Detailed Cleaning Methods

The purpose of sewer cleaning is to remove foreign material from the sewer and generally is undertaken to alleviate one of the following conditions:

17. \_\_\_\_\_ is caused by either the premature operation of combined wastewater overflows because of downstream restrictions to hydraulic capacity or pollution caused by the washing through and discharge of debris from overflows during storms.

18. \_\_\_\_\_ is caused by the retention of solids in the system for long periods resulting in, among other things, wastewater turning septic and producing hydrogen sulfide.

### Answers

1. 20-30, 2. Blockages, 3. Cleaning and inspecting sewer lines, 4. Jetting, 5. Scooter, 6. Kites, Bags, and Poly Pigs, 7. Mechanical Rodding, 8. Bucket Machine, 9. Hydraulic Balling, 10. Flushing, 11. Problems, 12. Cleaning and repairs, 13. Corrosion potential, 14. Pipe diameter/volume conveyed, 15. The collection system, 16. Combination trucks and TV trucks, 17. Pollution, 18. Odor

## Chapter 6- FATS, OILS AND GREASE SECTION

**Section Focus:** You will learn the basics of the Clean Water Act, the need for FOG fats, oils and grease regulation and enforcement. At the end of this section, you the student will be able to describe the need for fats, oils and grease regulation, enforcement and public education. There is a post quiz at the end of this section to review your comprehension and a final examination in the Assignment for your contact hours.

**Scope/Background:** The CWA made it unlawful to discharge any pollutant (FOG) from a point source into navigable waters, unless a permit was obtained. EPA's National Pollutant Discharge Elimination System (NPDES) permit program controls discharges. Food service establishments deal with large volumes of FOG on a daily basis. FOG can have a very negative impact if not handled properly. It can cause serious damage to the sewer system, your property and that of your neighbors, as well as, damage the environment and public health concerns. Cleanup of sewer overflows can be very costly and this expense translates to higher bills for sewer customers. By being aware of what FOG can do to your surroundings, it is easier to take that extra minute to do your part and prevent FOG from ending up in the sewer.

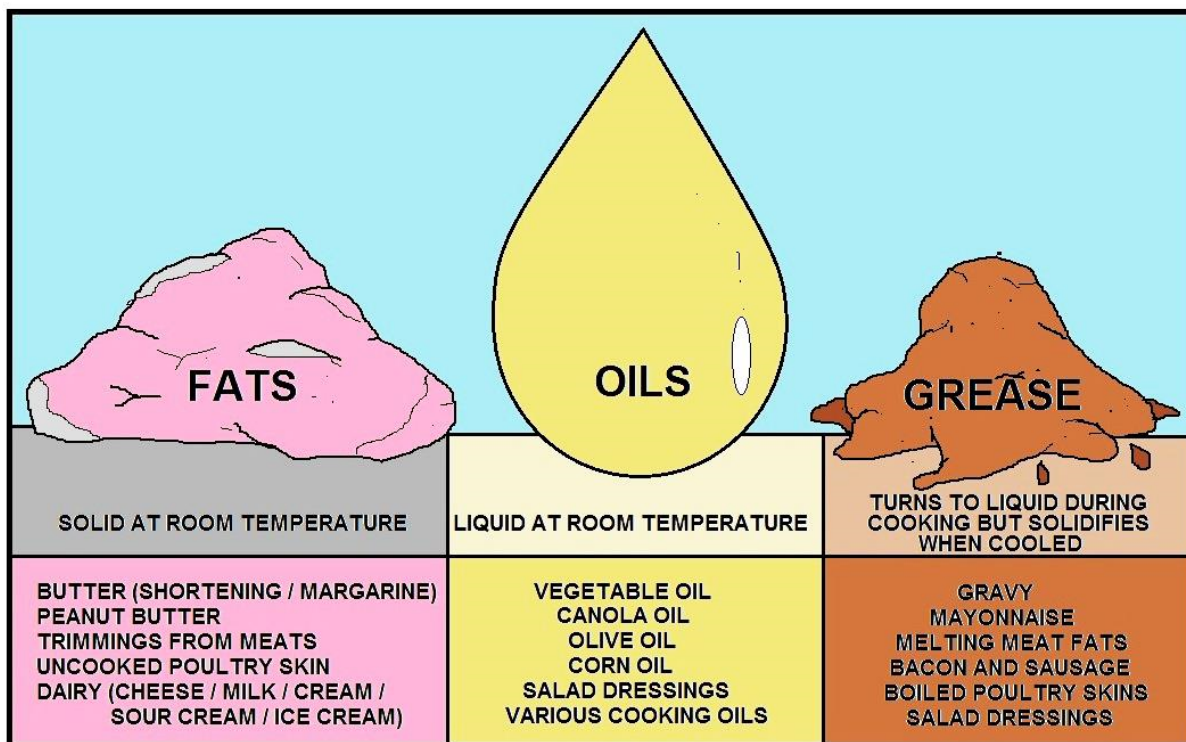

### FOG (FATS/OILS/GREASE) CONTRIBUTORS

Most stoppages in the sewer system are caused by grease. It is best to have a strong FOG Ordinance that prevents restaurants from dumping grease into the system. You as the regulator will need a process of back charging the restaurants that do clog the sewers as payment for cleaning. As a pretreatment inspector, you will visit many restaurants for grease violations.

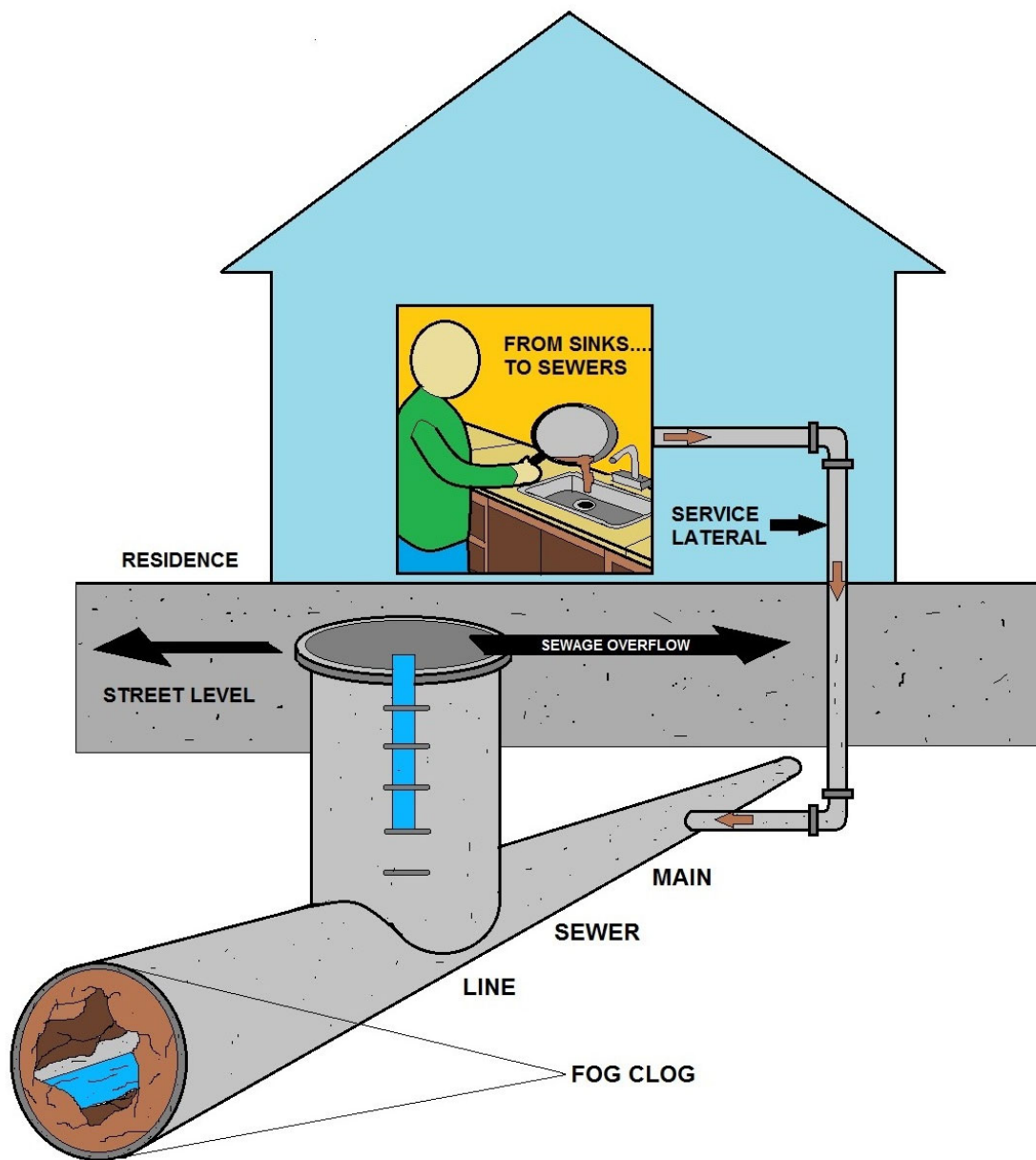

**HOW SEWERS ARE CLOGGED BY GREASE DIAGRAM**

**Keeping Fats, Oils, and Grease out of the Sewer System**

Fats, oils, and grease—FOG—comes from meat fats in food scraps, cooking oil, shortening, lard, butter and margarine, gravy, and food products such as mayonnaise, salad dressings, and sour cream.

FOG poured down kitchen drains accumulates inside sewer pipes and cause damage to the collection system. As the FOG builds up, it restricts the flow in the pipe and can cause untreated wastewater to back-up into homes and businesses, resulting in high costs for cleanup and restoration.



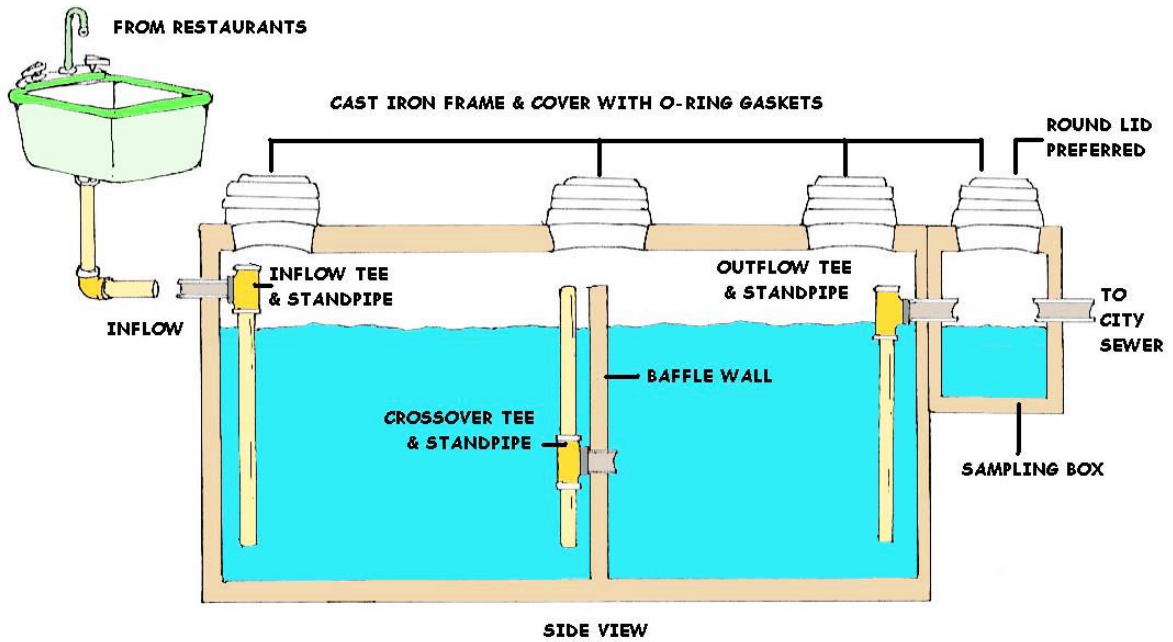

Cooking grease coats pipelines much like fatty foods clog human arteries. The grease clings to the insides of the pipe, eventually causing blockage and potential sewer spills. By following a few simple steps, customers can help prevent costly sewer spills in the future.

- All cooking oil (this includes salad oil, frying oil and bacon fat) should be poured into an old milk carton, frozen juice container, or other non-recyclable package, and disposed of in the garbage.
- Dishes and pots that are coated with greasy leftovers should be wiped clean with a disposable towel prior to washing or placing in the dishwasher.
- Instead of placing fat trimmings from meat down the garbage disposal, place them in a trash can.



Vactor

## **FOG Problems**

Manholes can overflow into parks, yards, streets, and storm drains, allowing FOG to contaminate local waters, including drinking water. Exposure to untreated wastewater is a public-health hazard and is an EPA violation. FOG discharged into septic systems and drain fields can cause malfunctions, resulting in more frequent tank pump-outs and other expenses.

Restaurants, cafeterias, and fast-food establishments spend tens of thousands of dollars on plumbing emergencies each year to deal with grease blockages and pump out grease traps and interceptors. Some cities also charge businesses for the repair of sewer pipes and spill cleanup if they can attribute the blockage to a particular business.

Some cities also add a surcharge to wastewater bills if a business exceeds a specified discharge limit. These expenses can be a significant.

Communities spend billions of dollars every year unplugging or replacing grease-blocked pipes, repairing pump stations, and cleaning up costly and illegal wastewater spills. Excessive FOG in the sewer system can affect local wastewater rates. So, keeping FOG out of the sewer system helps everyone in the community.

## **Controlling Fats, Oils, and Grease Discharges from Food Service Establishments**

FOG gets into our sewer collection system mainly from residential customers pouring the substances down their drains and from commercial food preparation establishments with inadequate grease controls. Fats, oils and grease are a byproduct of cooking and are mostly found in the following:

- ✓ Meats
- ✓ Cooking oil
- ✓ Lard or shortening
- ✓ Butter or margarine

Our sewer system is not designed to handle or treat these substances in excess. Over time, without proper disposal of fats, oils and grease, they build up in the sewer system and eventually block collection pipes and sewer lines, resulting in sewer backups and overflows on streets, properties and even in customers' homes and/or businesses. Overflows may also impact the environment negatively and can result in contamination of ponds, streams or rivers.

## **Food Service Establishments (FSEs)**

Food Service Establishments (FSEs) are a significant source of fats, oil and grease (FOG) because of the amount of grease used in cooking. POTW Commercial FOG Programs are generally developed to assist restaurants and other FSEs with proper handling and disposal of their FOG. Through implementation of Best Management Practices (BMPs), these establishments should be able to significantly reduce the amount of FOG that goes down their drains. This will minimize back-ups and help business owners comply with the POTW's requirements.

To work effectively, sewer systems need to be properly maintained, from the drain to the treatment plant. If wastes are disposed of correctly, the POTW's sewer system can handle them without any problem.

## Grease Trap

The trap prevents excess grease from getting into the sewer system from existing plumbing lines within facilities. Traps are small and are usually installed inside a facility. Generally, they range in size from 20 gallons per minute (gpm) to 50 gpm.



Infloor grease trap being removed and replaced with a grease interceptor.



Looking down into a grease interceptor commonly used in a commercial food service operations.

## Grease Interceptor Diagrams

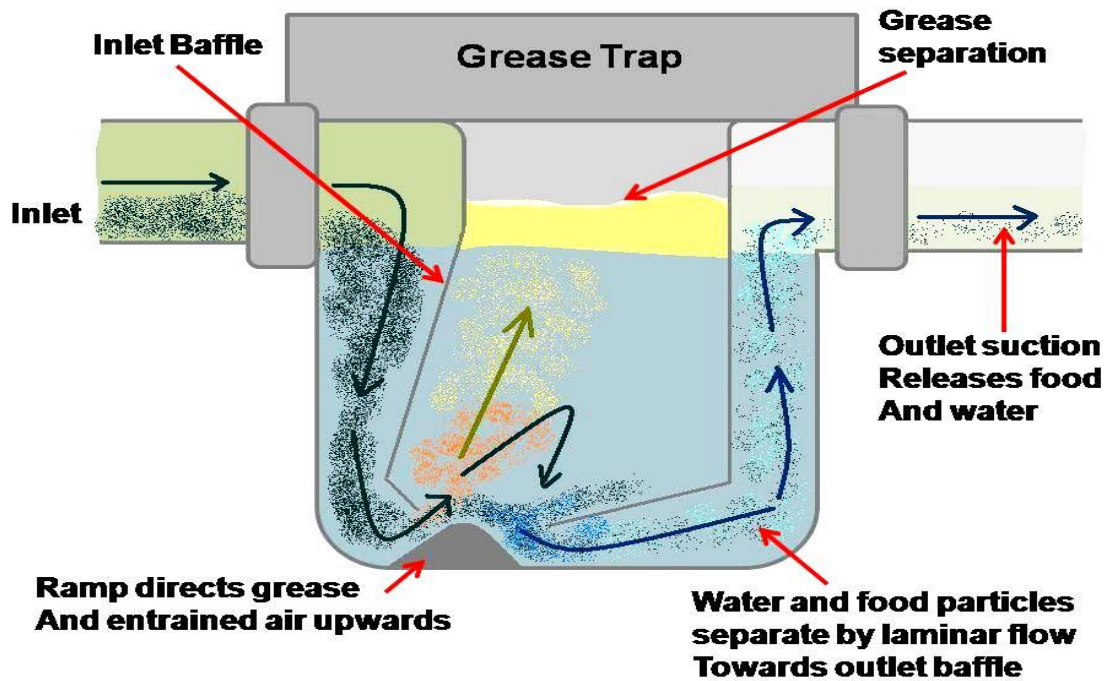
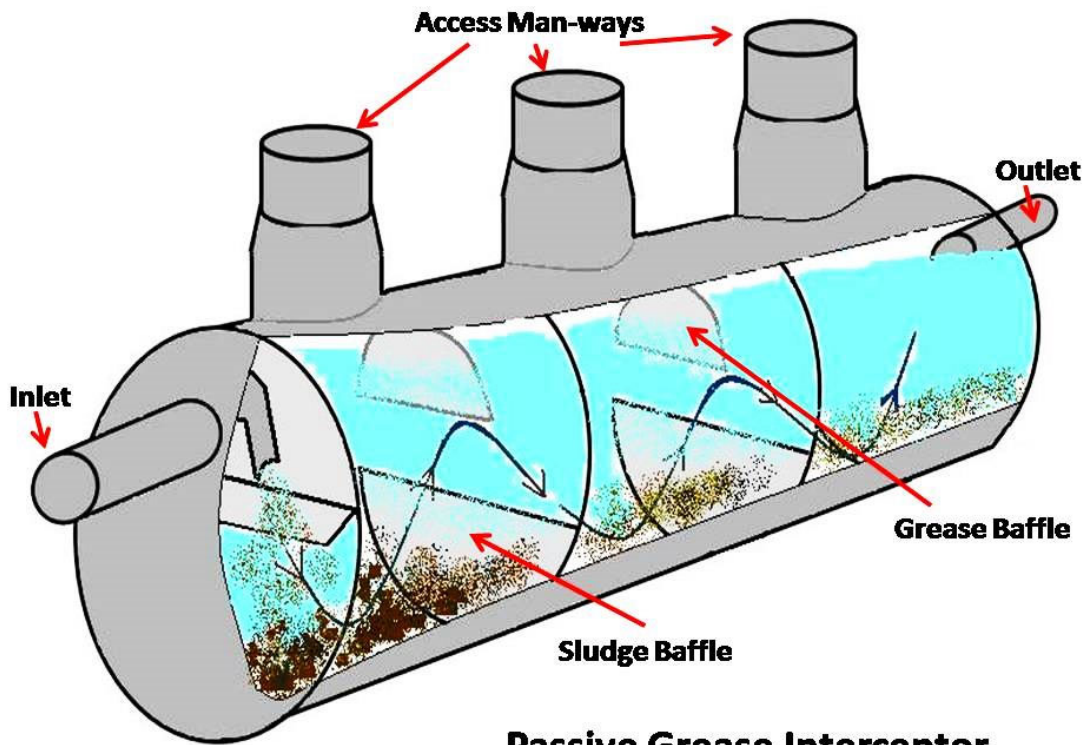

## Grease Interceptor Sub-Section

High-volume or new establishments use grease interceptors that are larger than the traps and are installed underground, outside of a facility. Grease is actually "intercepted" in these concrete or fiberglass tanks before it reaches the sewer main. Grease interceptors should be accessible by three manhole covers, and a sample box. Interceptors and traps cause the flow of water to slow down, allowing the grease to naturally float to the top of the tank for easy removal.

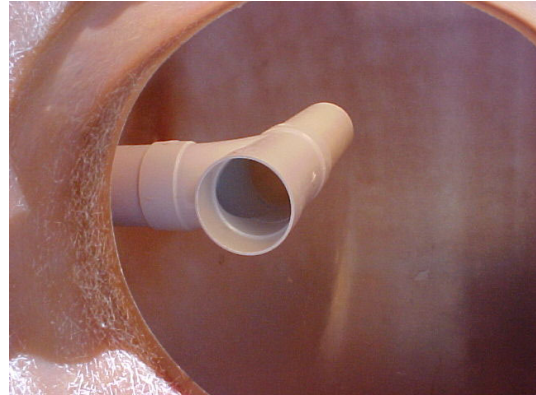

New fiberglass three compartment grease interceptor. You will need to fill the interceptor with water before connecting it to the sewer main.

### Plan Checks and Inspections

All plans for new commercial food establishments (including new construction remodels and retrofits) should receive a plan review from the POTW. This review assures that appropriate grease-removal equipment is installed during construction.

### Grease Blockages

Shortly after sewer-spills caused by grease are reported or discovered, POTW inspectors investigate facilities within the immediate area. A determination is made as to which commercial facilities contributed to the blockage, and more in-depth inspections are conducted at those facilities.

Where appropriate, additional requirements and/or procedures are put in place. When requirements are made for additional grease-removal equipment, the facility is given a due date to comply.

A Notice of Violation, with an administrative fee, is issued once a facility has passed its final due date. Administrative hearings, permit revocation, and ultimately, termination of sewer service may occur for those facilities that remain out of compliance.

### Regular Grease Inspection

Regular inspection and maintenance is essential to the proper operation of a grease removal device. The local ordinance should require a minimum cleaning frequency of once every six months.

However, that frequency will increase depending on the capacity of the device, the amount of grease in the wastewater, and the degree to which the facility has contributed to blockages in the past.

Regular cleaning at the appropriate interval is necessary to maintain the rated efficiency of the device. Equipment that is not regularly maintained puts the food service facility at risk of violating the sewer use ordinance, and this may not be known until an overflow and violation have occurred.

Most POTWs suggest businesses start with quarterly cleanings and should be done when 75 percent of the retention capacity of the unit is 75 percent full of accumulated grease. A large measuring stick and/or a clear piece of conduit may be used to determine the depth of the grease accumulation. You should require that restaurants contract with a licensed grease hauler to remove it from the premises for appropriate disposal.

### **Choosing a Grease Hauler**

When you speak to a restaurant owner, inform them that while selecting a grease hauler, be aware that services and prices can vary. Minimum services should include:

- Complete pumping and cleaning of the interceptor and sample box, rather than just skimming the grease layer.
- Deodorizing and thorough cleaning of affected areas, as necessary.
- Disposal/reclamation at an approved location.
- Notes concerning the condition of the interceptor
- Complete pumping and cleaning record.

The restaurant owner and grease hauler should agree on an adequate cleaning frequency to avoid blockage of the line. Waste grease from a kitchen is recyclable for use in making soap, animal feed, etc. Grease from a grease trap or interceptor may not be reused in this way. For recyclable grease, some POTWs recommend that all facilities have waste grease containers with tight fitting lids that are either secondarily contained or kept in a bermed area to protect floor drains and storm drain inlets from spills.

### **Keeping up-to-date Records**

Careful record keeping is one of the best ways to ensure that the grease removal device is being cleaned and maintained on a regular basis. City codes and ordinances require records be maintained for a minimum of three to five years.

### **Other Types of Devices**

A grease trap may be approved in lieu of an interceptor for full service food service facilities only in very limited circumstances when space is not available. Grease traps may also be approved by the Industrial Pretreatment Program for facilities such as delicatessens and small bakeries that produce small quantities of oil, grease, or fat. Refer to the International Plumbing Code for requirements related to grease traps such as installation of flow-control devices, flow rates, and other structural requirements.

**Please Note:** Flow restrictors are required for grease traps because they increase retention time and efficiency.

Automatic grease skimming devices collect small volumes of water and remove grease into a side container at preset times each day. Usually, special approval from the

Industrial Pretreatment Staff or the POTW is required to install one of these devices in lieu of a grease interceptor.

### **Magic Grease “Bugs” and Bacterial Additives**

Manufacturers of bacterial additives claim that their products remove grease and enhance the performance of grease traps and interceptors. Such additives cannot be substituted for a grease removal device and regular inspection and maintenance.

If a customer decides to use an additive, they need to make sure the product you select is not an emulsifier, which simply keeps grease in suspension temporarily and allows it to flow to the sewer system.

### **Obtaining necessary permits**

- Building departments prefer in-ground installations that drain by gravity to the sanitary sewer. Avoid pumps and other mechanical devices in your connection to the sewer if possible.
- The interceptor or grease trap needs to be properly sized in accordance with the International Plumbing Code, IAPMO, or local ordinance.

### **Chain Cutter**

This tool is attached to the flush truck. When water pressure is applied, the 3 chains at the head spin at tremendous speeds. These spinning chains will cut roots, grease build-up, and even a protruding tap.



This is a sewer line that has a large amount of grease buildup that will be cut out. Grease gets into the sewer line by pouring grease left over from cooking, down the kitchen sink.

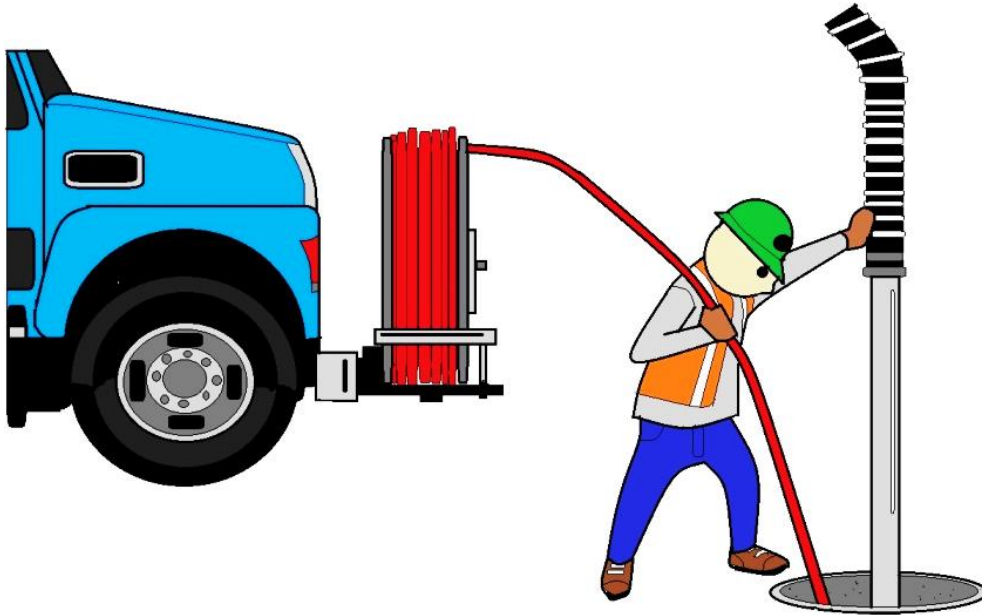

**USING A VACUUM TRUCK TO CLEAN SEWER**  
Often the Vector is called out to clean out the above concerns.

The POTW needs businesses and individuals to do their part to maintain the system because repeated repairs are disruptive to residences and businesses alike. Furthermore, proper disposal by commercial establishments is required by law.



## Interceptors and Traps- Plan Checks and Inspections

*As a collection operator, you will need knowledge of many different concerns in order to properly identify the problem.*

All plans for new commercial food establishments (including new construction remodels and retrofits) should receive a plan review from the POTW. This review assures that appropriate grease-removal equipment is installed during construction.

### **Grease Blockages**

Shortly after sewer-spills caused by grease are reported or discovered, POTW inspectors or Collection Inspectors investigate facilities within the immediate area. A determination needs to be made as to which commercial facilities contributed to the blockage, and more in-depth inspections are conducted at those facilities. Where appropriate, additional requirements and/or procedures are put into place. When requirements are made for additional grease-removal equipment, the facility is given a due date to comply. A Notice of Violation (NOV), with an administrative fee, is issued once a facility has passed its final due date. Administrative hearings, permit revocation, and ultimately, termination of sewer service may occur for those facilities that remain out of compliance.

### **Regular Grease Inspection**

Regular inspection and maintenance is essential to the proper operation of a grease removal device. The local ordinance should require a minimum cleaning frequency of once every six months. However, that frequency will increase depending on the capacity of the device, the amount of grease in the wastewater, and the degree to which the facility has contributed to blockages in the past.

Regular cleaning at the appropriate interval is necessary to maintain the rated efficiency of the device. Equipment that is not regularly maintained puts the food service facility at risk of violating the sewer use ordinance, and this may not be known until an overflow and violation have occurred.

Most POTWs suggest businesses start with quarterly cleanings that should be done when 75 percent of the retention capacity of the unit is full of accumulated grease. A large measuring stick and/or a clear piece of conduit may be used to determine the depth of the grease accumulation.

You should contract with a licensed grease hauler to remove it from the premises for appropriate disposal.

### **Choosing a Grease Hauler**

When the customer needs to select a grease hauler, they should be aware that services and prices can vary.

Minimum services should include:

- Complete pumping and cleaning of the interceptor and sample box, rather than just skimming the grease layer.
- Deodorizing and thorough cleaning of affected areas, as necessary.
- Disposal/reclamation at an approved location.

- Notes concerning the condition of the interceptor.
- Complete pumping and cleaning record.

**The Customer and the hauler should agree on an adequate cleaning frequency to avoid blockage of the line.**

### **Recyclable grease storage**

Waste grease from a kitchen is recyclable for use in making soap, animal feed, etc. Grease from a grease trap or interceptor may not be reused in this way.

For recyclable grease, some POTWs recommend that all facilities have waste grease containers, with tight fitting lids, that are either secondarily contained or kept in a bermed area to protect floor drains and storm drain inlets from spills.

### **Keeping up-to-date Records**

Careful record keeping is one of the best ways to ensure that your grease removal device is being cleaned and maintained on a regular basis. City codes and ordinances require records be maintained for a minimum of three to five years.

### **Other Types of Devices**

Often but not always, a grease trap or several traps may be approved in lieu of an interceptor for full service food service facilities only in very limited circumstances when space is not available.

Grease traps may also be approved by the Industrial Pretreatment Program for facilities such as delicatessens and small bakeries that produce small quantities of oil, grease, or fat. Refer to the Plumbing Code for requirements related to grease traps such as installation of flow-control devices, flow rates, and other structural requirements.

**Please Note:** flow restrictors are required for grease traps because they increase retention time and efficiency. Automatic grease skimming devices collect small volumes of water and remove grease into a side container at preset times each day.

Usually, special approval from the Industrial Pretreatment Staff or the POTW is required to install one of these devices in lieu of a grease interceptor.

### **Magic Grease Eating “Bugs” and Bacterial Additives**

Manufacturers of bacterial additives claim that their products remove grease and enhance the performance of grease traps and interceptors. Such additives cannot be substituted for a grease removal device, cleaning, regular inspection and maintenance.

If a customer decides to use an additive, they need to make sure the product you select is not an emulsifier, which simply keeps grease in suspension temporarily and allows it to flow to the sewer system.

### **Obtaining Necessary Permits - Fixture Unit Loading Calculation**

- Building departments prefer in-ground installations that drain by gravity to the sanitary sewer. Avoid pumps and other mechanical devices in your connection to the sewer if possible.
- The interceptor or grease trap needs to be properly sized (fixture unit loading) in accordance with the International Plumbing Code, IAPMO, or local ordinance.

## Controlling FOG Discharges

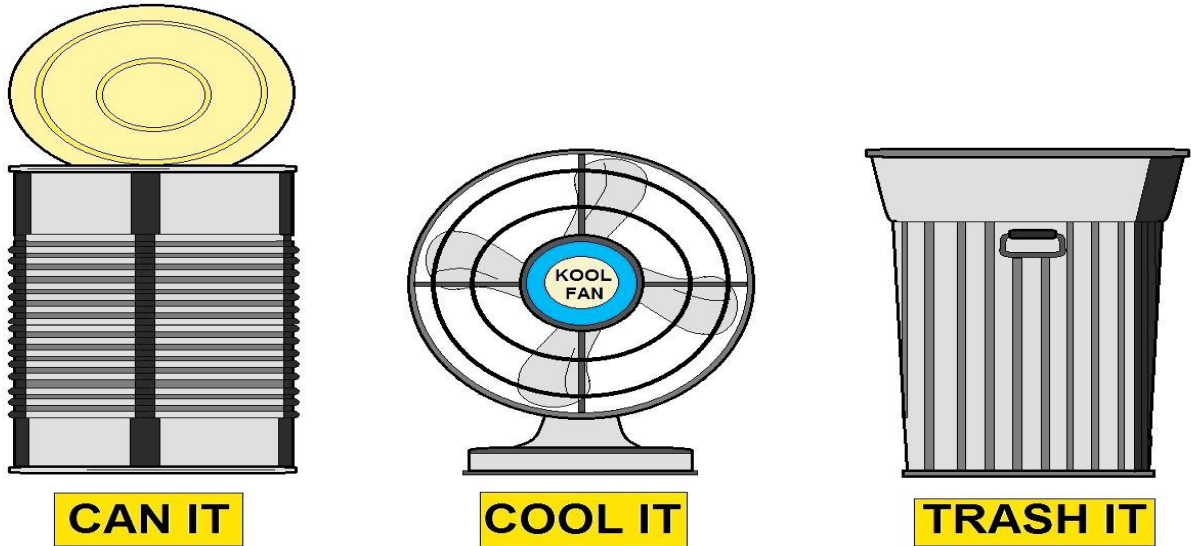

### METHODS OF PROPER GREASE DISPOSAL

FOG wastes are generated at FSEs as byproducts from food preparation activities. FOG captured on-site is generally classified into two broad categories: yellow grease and grease trap waste. Yellow grease is derived from used cooking oil and waste greases that are separated and collected at the point of use by the food service establishment.

The annual production of collected grease trap waste and uncollected grease entering sewage treatment plants can be significant and ranges from 800 to 17,000 pounds/year per restaurant.

The National Pretreatment Program already provides the necessary regulatory tools and authority to local pretreatment programs for controlling interference problems. Under the provisions of Part 403.5(c)(1) & (2), in defined circumstances, a POTW must establish specific local limits for industrial users to guard against interference with the operation of the municipal treatment works.

Consequently, pretreatment oversight programs should include activities designed to identify and control sources of potential interference and, in the event of actual interference, enforcement against the violator.

Food service establishments can adopt a variety of best management practices or install interceptor/collector devices to control and capture the FOG material before discharge to the collection system.

For example, instead of discharging yellow grease to POTWs, food service establishments usually accumulate this material for pick up by consolidation service companies for re-sale or re-use in the manufacture of tallow, animal feed supplements, bio-fuels, or other products. Additionally, food service establishments can install interceptor/collector devices (e.g., grease traps) in order to accumulate grease on-site and prevent it from entering the POTW collection system.

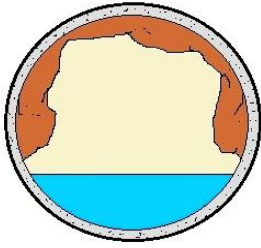

**THE START OF BLOCKED PIPE BEGINS WITH SOLIDS AND GREASE COLLECTING ON TOP AND SIDES OF PIPE INTERIOR.**

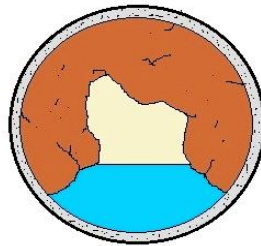

**OVER TIME, THE BUILD-UP INCREASES WHEN GREASE AND DEBRIS ARE WASHED DOWN A DRAIN.**

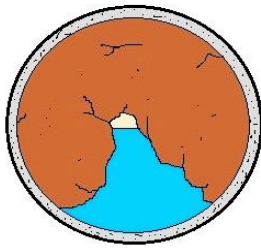

**EXCESSIVE ACCUMULATION RESTRICTS THE FLOW OF WASTEWATER THAT CAN RESULT IN AN OVERFLOW OF SANITARY SEWER**

## **HOW SEWER BLOCKAGES FORM**

### **POTWs control methods for FOG discharges from FSEs**

Proper design, installation, and maintenance procedures are critical for these devices to control and capture the FOG.

*For example,*

- ✓ Interceptor/collector devices must be designed and sized appropriately to allow FOG to cool and separate in a non-turbulent environment.
- ✓ FSE must be diligent in having their interceptor/ collector devices serviced at regular intervals.

## Methods of Recycling FOG

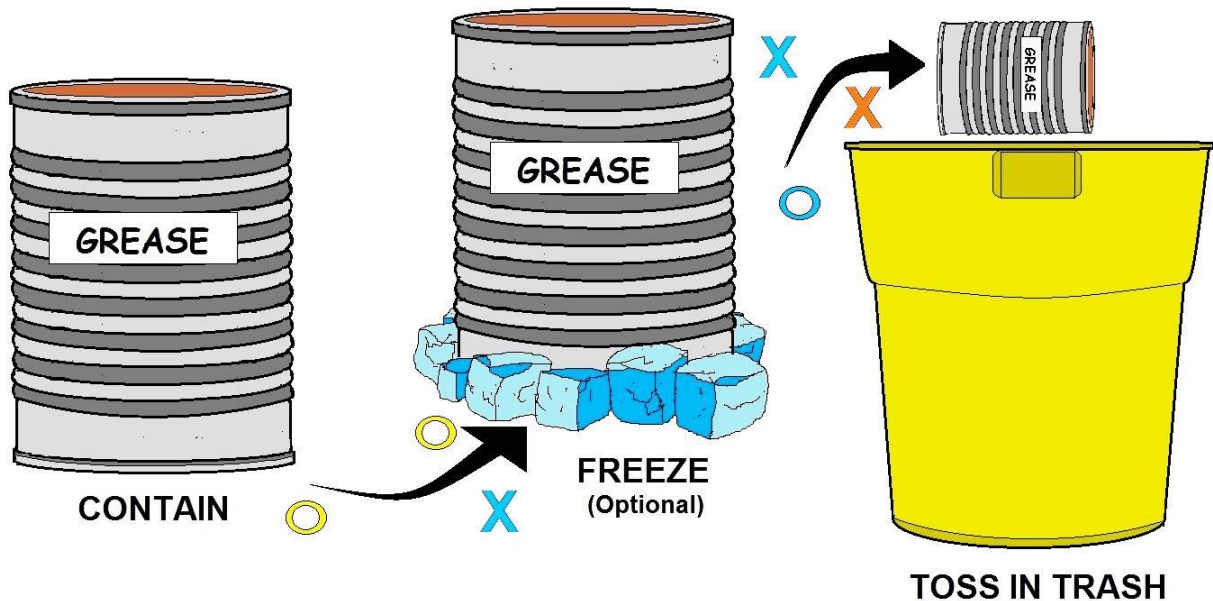

**THE SINK SHOULD NEVER BE USED TO DISPOSE OF:  
OILS , FATS OR GREASE**

**FOG Customers and Violators Should be Encouraged or Written Up to...**

### **Rendering FOG**

Liquid fats and solid meat products can be used as raw materials in the rendering industry, which converts them into animal food, cosmetics, soap, and other products. Many companies will provide storage barrels and free pick-up service.

### **Converting FOG to Biodiesel**

FOG are collected and converted by a local manufacturer into environmentally friendly biodiesel fuel. Biodiesel is an alternative fuel produced from renewable resources such as virgin oils (soybean, canola, palm), waste cooking oil, or other bio-waste feedstock.

Biodiesel significantly reduces greenhouse gases, sulfur dioxide in air emissions, and asthma-causing soot. Along with creating less pollution, biodiesel is simple to use, biodegradable and nontoxic.

### **Inspection Checklists**

Pretreatment programs are developing and using inspection checklists for both food service establishments and municipal pretreatment inspectors to control FOG discharges.

Additionally, EPA identified typical numeric local limits controlling oil and grease in the range of 50 mg/L to 450 mg/L with 100 mg/L as the most common reported numeric pretreatment limit.

EPA expects that blockages from FOG discharges will decrease as POTWs incorporate FOG reduction activities into their Capacity, Management, Operations, and Maintenance (CMOM) program and daily practices.

CMOM programs are comprehensive, dynamic, utility specific programs for better managing, operating and maintaining sanitary sewer collection systems, investigating capacity constrained areas of the collection system, and responding to SSOs.

Collection system owners or operators who adopt FOG reduction activities as part of their CMOM program activities are likely to reduce the occurrence of sewer overflows and improve their operations and customer service.

### **FOG Customers Using Best Management Practices Can:**

- Lessen the likelihood of customer's losing revenue to emergency shutdowns caused by sewage backups and expensive bills for plumbing and property repairs.
- Lessen the likelihood of customer's lawsuits by nearby businesses over sewer problems caused by negligence.
- Lessen the likelihood of customer's lawsuits from workers or the public exposed to raw sewage during a backup.
- Reduce the number of times customers have to pump and clean your grease interceptors or traps.
- Lessen the likelihood of surcharges from the local sewer authority, or chargebacks for repairs to sewer pipes attributable customer's FOG.
- Reduce testing customer's requirements imposed due to a history of violations.
- Lessen the likelihood of customer's enforcement action by POTW authorities due to violations of ordinances.

## Industrial Uses (Fats, Oils, and Grease)

### Fats, Oils, and Grease Resources

Liquid fats and solid meat products are materials that should not be sent to landfills or disposed of in the sanitary sewer system. Fats, oils, and grease (FOG) can clog pipes and pumps both in the public sewer lines as well as in wastewater treatment facilities. This prevents combined sewer overflows, which protects water quality and lowers bills. FOG should be sent to the rendering industry to be made into another product, converted to biofuels, or sent to an anaerobic digester.

### Proper Disposal Methods

Ways in which you as a customer can reduce the amounts of FOG that enters the sewer system is by doing the following:

- ✓ Have grease interceptors or traps inspected, maintained and cleaned regularly. (Usually every 6 months they should be pumped out).
- ✓ Scrape grease and food residue from dishes and pans into a garbage bag before placing them into your dishwasher or sink.
- ✓ Allow grease to cool to a safe temperature after cooking before disposal.
- ✓ Only dispose of fat and grease in an approved container or by an approved method.
- ✓ Recycle used cooking or motor oil at a recycling center.
- ✓ First freeze the grease or oil and then throw the hardened oil away on trash day.
- ✓ Mix oils with unscented kitty litter, sawdust or sand to solidify the oil (Avoid scented or disinfectant types of kitty litter as they can react with the oil and cause a fire).
- ✓ Use a paper towel to wipe small amounts of cooking oil, such as meat drippings, and throw the paper towel in the trash.
- ✓ Install "No Grease" signs around sinks to remind employees to avoid dumping fry grease and other fat products down the drain.
- ✓ Frying oils can generally be stored for up to six months and also can be reused for up to six hours of frying time. Store oil in the original container after cooling and strain for foreign materials as it is being poured back into the container.

### Methods that should be avoided:

- ✓ Pouring household grease into sinks, garbage disposals or other drains. This is one of the major contributors to sewer stoppages.
- ✓ Flushing grease, diapers, sanitary napkins, newspapers, soiled rags, and/or paper towels down toilets.
- ✓ Pouring oil or grease into a storm drain; it is the same as pouring it directly into a lake.
- ✓ Ignoring your grease trap maintenance schedule.

### National Pretreatment Program's Tools

The National Pretreatment Program provides regulatory tools and authority to state and local POTW pretreatment programs for eliminating pollutant discharges that cause interference at POTWs, including interference caused by the discharge of Fats, Oils, and Grease (FOG) from food service establishments (FSE).

More specifically, the Pretreatment Program regulations at 40 CFR 403.5(b)(3) prohibit "solid or viscous pollutants in amounts which will cause obstruction" in the POTW and its collection system.

EPA's Report to Congress on combined sewer overflows (CSOs) and sanitary sewer overflows (SSOs) identified that "grease from restaurants, homes, and industrial sources are the most common cause (47%) of reported blockages.

Grease is problematic because it solidifies, reduces conveyance capacity, and blocks flow."

Controlling FOG discharges will help POTWs prevent blockages that impact CSOs and SSOs, which cause public health and water quality problems.

Controlling FOG discharges from FSEs is an essential element in controlling CSOs and SSOs and ensuring the proper operations for many POTWs. The interference incidents identified in CSO/SSO report to Congress may indicate the need for additional oversight and enforcement of existing regulations and controls.

### **Best Management Practices (BMPs)**

The required maintenance frequency for interceptor/collector devices depends greatly on the amount of FOG a facility generates as well as any best management practices (BMPs) that the establishment implements to reduce the FOG discharged into its sanitary sewer system. In many cases, an establishment that implements BMPs will realize financial benefit through a reduction in their required grease interceptor and trap maintenance frequency.

A growing number of control authorities are using their existing authority (e.g., general pretreatment standards in Part 403 or local authority) to establish and enforce more FOG regulatory controls (e.g., numeric pretreatment limits, best management practices including the use of interceptor/collector devices) for food service establishments to reduce interferences with POTW operations (e.g., blockages from fats, oils, and greases discharges, POTW treatment interference from Nocardia filamentous foaming, damage to collection system from hydrogen sulfide generation).

### **Non-Compliance Rate Example**

For example, since identifying a 73% non-compliance rate with its grease trap ordinance among restaurants, New York POTW has instituted a \$1,000-per-day fine for FOG violations. Likewise, more and more municipal wastewater authorities are addressing FOG discharges by imposing mandatory measures of assorted kinds, including inspections, periodic grease pumping, stiff penalties, and even criminal citations for violators, along with 'strong waste' monthly surcharges added to restaurant sewer bills. Surcharges are reportedly ranging from \$100 to as high as \$700 and more, the fees being deemed necessary to cover the cost of inspections and upgraded infrastructure.



## pH Testing Sub-Section

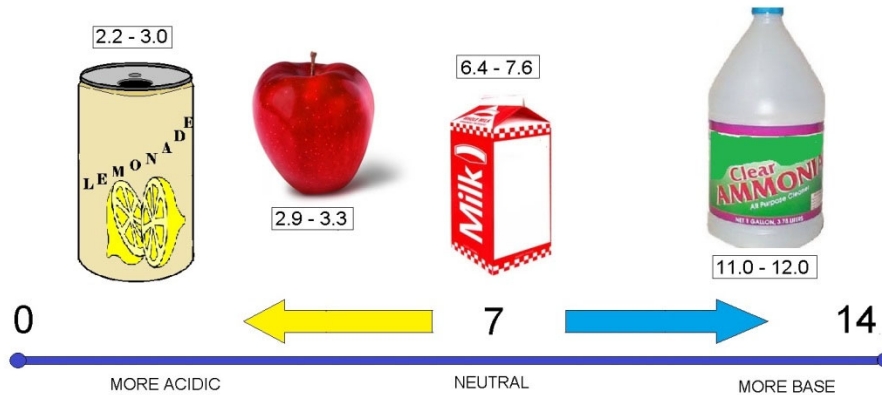

## pH SCALE

Because of FOG, it will lower the pH of the wastewater to very acidic conditions. You may be asked to test the pH of the wastewater to ensure the acid is not strong enough to cause corrosion to the sewer system.

In water and wastewater processes, **pH** is a measure of the acidity or basicity of an aqueous solution. Solutions with a pH greater than 7 are basic or alkaline and solution or samples with a pH less than 7 are said to be acidic. Pure water has a pH very close to 7.

Primary pH standard values are determined using a concentration cell with transference, by measuring the potential difference between a hydrogen electrode and a standard electrode such as the silver chloride electrode. The pH scale is traceable to a set of standard solutions whose pH is established by international agreement.

Measurement of pH for aqueous solutions can be done with a glass electrode and a pH meter, or using indicators like strip test paper.

pH measurements are important in water and wastewater processes (sampling) but also in medicine, biology, chemistry, agriculture, forestry, food science, environmental science, oceanography, civil engineering, chemical engineering, nutrition, water treatment & water purification, and many other applications.

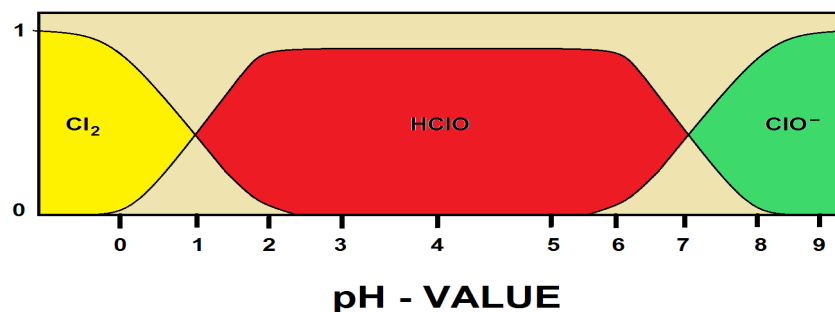

Mathematically, pH is the measurement of hydroxyl ion activity and expressed as the negative logarithm of the activity of the (solvated) hydronium ion, more often expressed as the measure of the hydronium ion concentration.

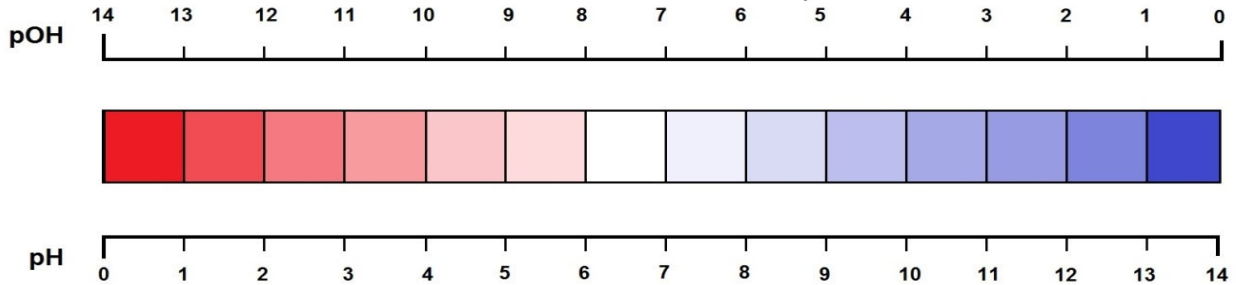

IN RELATION BETWEEN p(OH) AND p(H) (red= ACIDIC / blue= BASIC)

**Contents**

**History**

The scientific discovery of the p[H] concept of was first introduced by Danish chemist Søren Peder Lauritz Sørensen at the Carlsberg Laboratory back in 1909 and revised to the modern pH in 1924 to accommodate definitions and measurements in terms of electrochemical cells. In the first papers, the notation had the "H" as a subscript to the lowercase "p", as so: pH.

**Alkalinity**

Alkalinity is the quantitative capacity of an aqueous solution to neutralize an acid. Measuring alkalinity is important in determining a stream's ability to neutralize acidic pollution from rainfall or wastewater. It is one of the best measures of the sensitivity of the stream to acid inputs. There can be long-term changes in the alkalinity of rivers and streams in response to human disturbances.

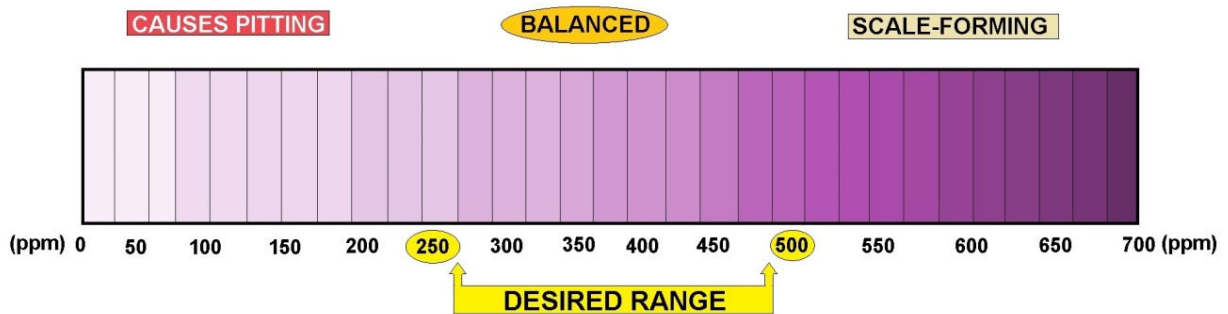

**CALCIUM HARDNESS MEASUREMENT**

Reference. Bates, Roger G. *Determination of pH: theory and practice*. Wiley, 1973.

## pH Definition and Measurements

CONCENTRATION OF HYDROGEN IONS COMPARED TO DISTILLED H <sub>2</sub> O	1/10,000,000	14	LIQUID DRAIN CLEANER CAUSTIC SODA	EXAMPLES OF SOLUTIONS AND THEIR RESPECTIVE pH
	1/1,000,000	13	BLEACHES OVEN CLEANERS	
	1/100,000	12	SOAPY WATER	
	1/10,000	11	HOUSEHOLD AMMONIA (11.9)	
	1/1,000	10	MILK OF MAGNESIUM (10.5)	
	1/100	9	TOOTHPASTE (9.9)	
	1/10	8	BAKING SODA (8.4) / SEA WATER EGGS	
	0	7	"PURE" WATER (7)	
	10	6	URINE (6) / MILK (6.6)	
	100	5	ACID RAIN (5.6) BLACK COFFEE (5)	
	1000	4	TOMATO JUICE (4.1)	
	10,000	3	GRAPEFRUIT & ORANGE JUICE SOFT DRINK	
	100,000	2	LEMON JUICE (2.3) VINEGAR (2.9)	
	1,000,000	1	HYDROCHLORIC ACID SECRETED FROM STOMACH LINING (1)	
	10,000,000	0	BATTERY ACID	

### pH Scale

#### Technical Definition of pH

In technical terms, pH is defined as the decimal logarithm of the reciprocal of the hydrogen ion activity,  $a_{H^+}$ , in a solution.

$$pH = -\log_{10}(a_{H^+}) = \log_{10}\left(\frac{1}{a_{H^+}}\right)$$

Ion-selective electrodes are often used to measure pH, respond to activity.

In this calculation of electrode potential,  $E$ , follows the Nernst equation, which, for the hydrogen ion can be written as

$$E = E^0 + \frac{RT}{F} \ln(a_{H^+}) = E^0 - \frac{2.303RT}{F} pH$$

where  $E$  is a measured potential,  $E^0$  is the standard electrode potential,  $R$  is the gas constant,  $T$  is the temperature in kelvin,  $F$  is the Faraday constant.

For  $H^+$  number of electrons transferred is one. It follows that electrode potential is proportional to pH when pH is defined in terms of activity.

International Standard ISO 31-8 is the standard for the precise measurement of pH as follows: A galvanic cell is set up to measure the electromotive force (EMF) between a reference electrode and an electrode sensitive to the hydrogen ion activity when they are both immersed in the same aqueous solution.

The reference electrode may be a silver chloride electrode or a calomel electrode. The hydrogen-ion selective electrode is a standard hydrogen electrode.

Reference electrode | concentrated solution of KCl || test solution | H<sub>2</sub> | Pt

Firstly, the cell is filled with a solution of known hydrogen ion activity and the emf,  $E_s$ , is measured. Then the emf,  $E_x$ , of the same cell containing the solution of unknown pH is measured.

$$pH(X) = pH(S) + \frac{E_s - E_x}{Z}$$

The difference between the two measured emf values is proportional to pH. This method of calibration avoids the need to know the standard electrode potential. The proportionality

constant,  $1/z$  is ideally equal to  $\frac{1}{2.303RT/F}$  the "Nernstian slope".

If you were to apply this practice the above calculation, a glass electrode is used rather than the cumbersome hydrogen electrode. A combined glass electrode has an in-built reference electrode. It is calibrated against buffer solutions of known hydrogen ion activity. IUPAC has proposed the use of a set of buffer solutions of known H<sup>+</sup> activity.

Two or more buffer solutions should be used in order to accommodate the fact that the "slope" may differ slightly from ideal.

The electrode is first immersed in a standard solution and the reading on a pH meter is adjusted to be equal to the standard buffer's value, to implement the proper calibration. The reading from a second standard buffer solution is then adjusted, using the "slope" control, to be equal to the pH for that solution. Further details, are given in the IUPAC recommendations.

When more than two buffer solutions are used the electrode is calibrated by fitting observed pH values to a straight line with respect to standard buffer values. Commercial standard buffer solutions usually come with information on the value at 25 °C and a correction factor to be applied for other temperatures.

The pH scale is logarithmic and pH is a dimensionless quantity.

## pH Calculations

The calculation of the pH of a solution containing acids and/or bases is an example of a chemical speciation calculation, that is, a mathematical procedure for calculating the concentrations of all chemical species that are present in the solution.

The complexity of the procedure depends on the nature of the solution.

If the pH of a solution contains a weak acid requires the solution of a quadratic equation.

If the pH of a solution contains a weak base may require the solution of a cubic equation.

For strong acids and bases no calculations are necessary except in extreme situations.

The general case requires the solution of a set of non-linear simultaneous equations.

A complicating factor is that water itself is a weak acid and a weak base. It dissociates according to the equilibrium

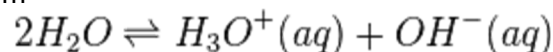

with a dissociation constant,  $K_w$  defined as

$$K_w = [H^+][OH^-]$$

where  $[H^+]$  represents for the concentration of the aquated hydronium ion and  $[OH^-]$  stands for the concentration of the hydroxide ion.  $K_w$  has a value of about  $10^{-14}$  at 25 °C, so pure water has a pH of approximately 7.

This equilibrium needs to be considered at high pH and when the solute concentration is extremely low.

### Hydrogen Ion pH Comparison Chart

pH	Hydrogen Ion Concentration, mmol/L
14	0.00000000000001
13	0.00000000000001
12	0.00000000000001
11	0.0000000000001
10	0.000000000001
9	0.0000000001
8	0.00000001
7	0.0000001
6	0.000001
5	0.00001
4	0.0001
3	0.001
2	0.01
1	0.1

## Strong Acids and Bases



### Strong Acids and Bases

Strong acids and bases are compounds that, for practical purposes, are completely dissociated in water. Under normal circumstances this means that the concentration of hydrogen ions in acidic solution can be taken to be equal to the concentration of the acid. The pH is then equal to minus the logarithm of the concentration value.

Hydrochloric acid (HCl) is an example of a strong acid. The pH of a 0.01M solution of HCl is equal to  $-\log_{10}(0.01)$ , that is,  $\text{pH} = 2$ .

Sodium hydroxide, NaOH, is an example of a strong base. The p[OH] value of a 0.01M solution of NaOH is equal to  $-\log_{10}(0.01)$ , that is,  $\text{p[OH]} = 2$ .

From the definition of p[OH] above, this means that the pH is equal to about 12. For solutions of sodium hydroxide at higher concentrations the self-ionization equilibrium must be taken into account.

### Weak Acids and Bases

A weak acid or the conjugate acid of a weak base can be treated using the same formalism.

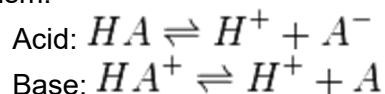

First, an acid dissociation constant is defined as follows. Electrical charges are omitted from subsequent equations for the sake of generality

$$K_a = \frac{[H][A]}{[HA]}$$

and its value is assumed to have been determined by experiment. This being so, there are three unknown concentrations, [HA], [H<sup>+</sup>] and [A<sup>-</sup>] to determine by calculation. Two additional equations are needed.

## FOG Summary

### Reducing Fats, Oils, and Grease in Your Commercial Kitchen

Any business or institution with a commercial kitchen has to deal with fats, oils, and grease (FOG). Commercial kitchens are found in restaurants, hospitals, churches, hotels, nursing homes, mobile food preparation facilities, etc.

### Environmental problem with FOG sewers

FOG that enters the sewer system eventually solidifies and forms grease balls. These grease balls can range in size from marbles to the size of cantaloupes and must be removed periodically. Since the sewer system is unable to handle or treat these substances effectively, this incurs greater expenditures on the maintenance of the collection systems and/or treatment plants which in turn can lead to higher customer rates.

Sewer backups can also cost customers thousands of dollars for the repair or replacement of their damaged property.

### Controlling FOG Discharges

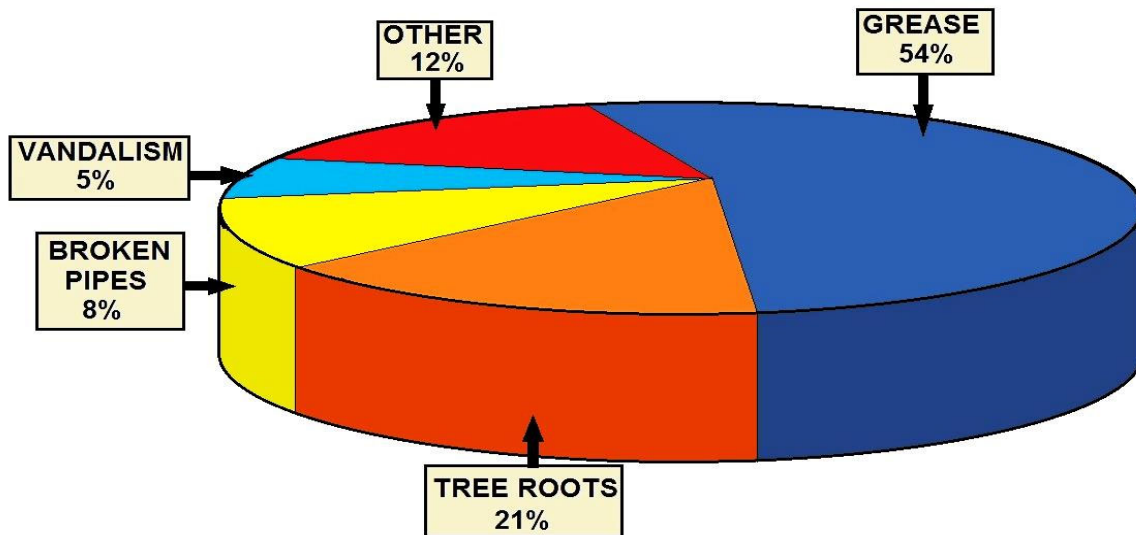

## CAUSES OF SANITARY SEWER OVERFLOWS

FOG wastes are generated at FSEs as by-products from food preparation activities. FOG captured on-site is generally classified into two broad categories: yellow grease and grease trap waste. Yellow grease is derived from used cooking oil and waste greases that are separated and collected at the point of use by the food service establishment.

The annual production of collected grease trap waste and uncollected grease entering sewage treatment plants can be significant and ranges from 800 to 17,000 pounds/year per restaurant.

The National Pretreatment Program already provides the necessary regulatory tools and authority to local pretreatment programs for controlling interference problems.

Under the provisions of Part 403.5(c)(1) & (2), in defined circumstances, a POTW must establish specific local limits for industrial users to guard against interference with the operation of the municipal treatment works.

Consequently, pretreatment oversight programs should include activities designed to identify and control sources of potential interference and, in the event of actual interference, enforcement against the violator.

Food service establishments can adopt a variety of best management practices or install interceptor/collector devices to control and capture the FOG material before discharge to the collection system. For example, instead of discharging yellow grease to POTWs, food service establishments usually accumulate this material for pick up by consolidation service companies for re-sale or re-use in the manufacture of tallow, animal feed supplements, bio-fuels, or other products.

Additionally, food service establishments can install interceptor/collector devices (e.g., grease traps) in order to accumulate grease on-site and prevent it from entering the POTW collection system.

### **Residential and Commercial Guidelines**

The fats, oil and grease (FOG) found in food ingredients such as meat, cooking oil, shortening, butter, margarine, baked goods, sauces and dairy products is a major concern for POTW's sewers. When not disposed of properly, FOG builds up in the sewer system constricting flow, which can cause sewer back-ups into homes and overflow discharges onto streets. It can also interfere with sewage treatment processes at the POTW's Wastewater Treatment Plants.

To remediate this problem, many control authorities have developed an outreach program aimed at eliminating FOG from the sewer system. FOG buildup in sewer lines has many harmful and costly effects.

Sewer backups into homes create a health hazard as well as an unpleasant mess that can cost hundreds and sometimes thousands of dollars to clean up. In certain parts of the POTW, FOG can enter storm drains and flow directly into water bodies and onto beaches creating serious environmental and health conditions.

In addition to problems caused by cooking oils, petroleum-based oils can also cause sewer-related problems. POTW residents or customers may not be aware of or understand their role in these sewer-related problems or pollution, but they can do a lot to help eliminate FOG and other contaminants from the sewer system.

#### ***For example:***

- Car washing can result in soap and oil residue entering the storm sewers.
- Run-off from your sprinkler, watering hose, or from the rain can carry yard waste and fertilizer into storm sewers.
- Littering can cause trash and debris to clog catch basins and storm drains.
- A gallon of oil poured down a storm drain could contaminate up to one million gallons of water.



## FOG Section Post Quiz

### Food Service Establishments (FSEs)

1. Because of the amount of grease used in cooking, \_\_\_\_\_ are a significant source of fats, oil and grease (FOG).
2. To assist improper handling and disposal of their FOG \_\_\_\_\_ are generally developed to assist restaurants and other FSEs with instruction and compliance.
3. The \_\_\_\_\_ can handle properly disposed wastes, but to work effectively, sewer systems need to be properly maintained, from the drain to the treatment plant.
4. Proper sewer disposal by commercial establishments is required by \_\_\_\_\_.

### Environmental problem with FOG sewers

5. The various sizes of grease balls can range in size from cantaloupes to the size of marble and must be removed periodically.  
A. *True*      B. *False*
6. The repair or replacement of their damaged property caused by FOG creating \_\_\_\_\_ can also cost customers thousands of dollars for the repair or replacement of their damaged property.

### Controlling FOG discharges

7. FOG wastes are generated at FSEs as byproducts from food preparation activities. FOG captured on-site is generally classified into two broad categories: yellow grease and grease trap waste.  
A. *True*      B. *False*
8. The POTW collection system(s) will require that certain food service establishments install interceptor/collector devices (e.g., grease traps) in order to accumulate grease on-site and prevent it from entering the?

### Keeping Fats, Oils, and Grease out of the Sewer System

9. Manholes can overflow into parks, yards, streets, and storm drains, allowing FOG to contaminate local waters, including drinking water. Exposure to untreated wastewater is a public-health hazard and is an EPA violation. FOG discharged into septic systems and drain fields can cause malfunctions, resulting in more frequent tank pump-outs and other expenses.  
A. *True*      B. *False*

10. \_\_\_\_\_ will back up into homes and businesses, resulting in high costs for cleanup and restoration?

**POTWs control methods for FOG discharges from FSEs**

11. FOG must be able to cool and separate in a non-turbulent environment, therefore. \_\_\_\_\_ must be designed and sized appropriately.

12. Grease interceptor/ collector devices shall be serviced at regular intervals and \_\_\_\_\_ must be diligent in providing proper maintenance and records.

**Best Management Practices (BMPs)**

13. The amount of FOG a facility generates as well as any best management practices (BMPs) that the establishment implements to reduce the FOG discharged into its sanitary sewer system.

A. True      B. False

**Answers**

1. Food Service Establishments (FSEs), 2. POTW Commercial FOG Program, 3. POTW's sewer system, 4. Law, 5. True, 6. Sewer backup(s), 7.True, 8. POTW collection system(s), 9. True, 10. Untreated wastewater, 11. Interceptor/collector device(s), 12. FSE, 13. True

## Chapter 7- COLLECTION RULES AND REGULATIONS

**Section Focus:** You will learn the Clean Water Act and the basics of the wastewater collection system. At the end of this section, you the student will be able to describe the basics of the Capacity, Management, Operation and Maintenance program. There is a post quiz at the end of this section to review your comprehension and a final examination in the Assignment for your contact hours.

**Scope/Background:** Sanitary sewage overflows that reach waters of the U.S. are point source discharges. Like other point source discharges from municipal sanitary sewer systems, sanitary sewage overflows are prohibited unless authorized by a NPDES permit. Moreover, SSOs, including those that do not reach waters of the U.S., may be indicative of improper operation and maintenance of the sewer systems, and may violate NPDES permit conditions.



### **What are Sanitary Sewer Overflows?**

Sanitary Sewer Overflows (SSOs) are discharges of raw sewage from municipal sanitary sewer systems. SSOs can release untreated sewage into basements or out of manholes and onto city streets, playgrounds, and into streams before it can reach a treatment facility. SSOs are often caused by blockages and breaks in the sewer lines.

### **Why do Sewers Overflow?**

SSOs occasionally occur in almost every sewer system, even though systems are intended to collect and contain all the sewage that flows into them. When SSOs happen frequently, it means something is wrong with the system.

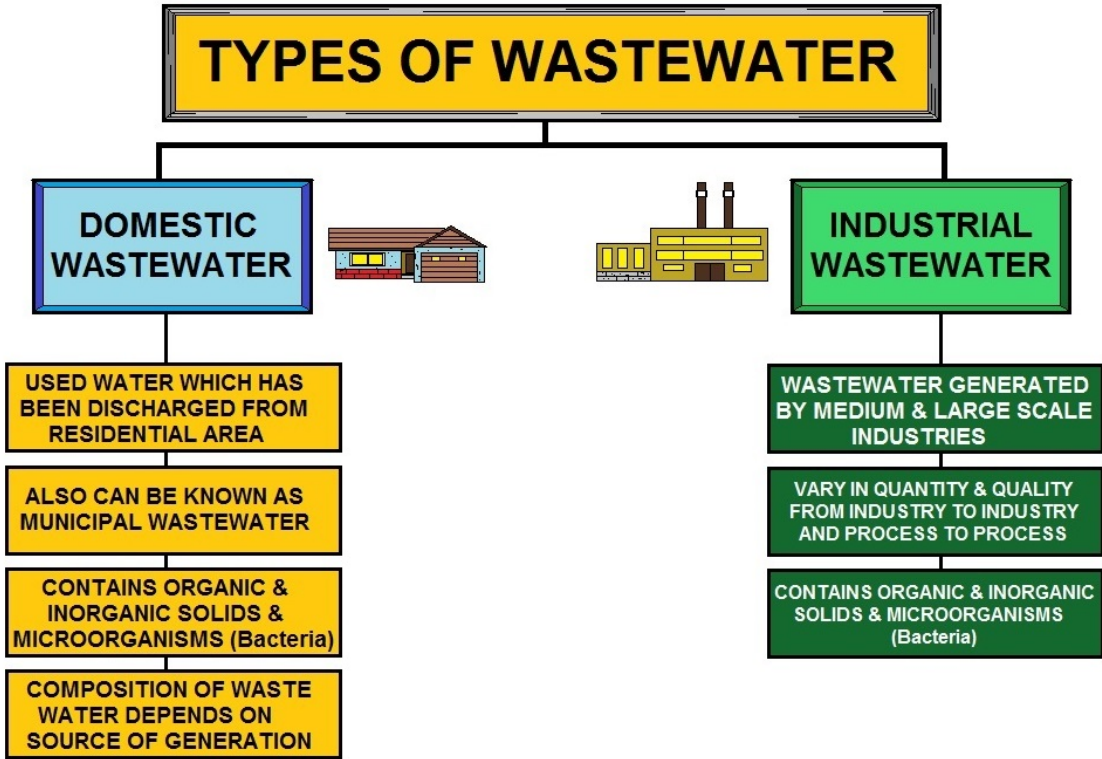

## WASTEWATER TYPES

## Clean Water Act Preface *(Credit USEPA)*

### 33 U.S.C. s/s 1251 et seq. (1977)

The Clean Water Act is a 1977 amendment to the Federal Water Pollution Control Act of 1972, which set the basic structure for regulating discharges of pollutants to waters of the United States.

The law gave the EPA the authority to set effluent standards on an industry basis (technology-based) and continued the requirements to set water quality standards for all contaminants in surface waters. The CWA makes it unlawful for any person to discharge any pollutant from a point source into navigable waters unless a permit (NPDES) is obtained under the act.

The 1977 amendments focused on toxic pollutants. In 1987, the PCA was reauthorized and again focused on toxic substances, authorized citizen suit provisions, and funded sewage treatment plants (POTW's) under the Construction Grants Program.

The CWA made provides for the delegation by the EPA of many permitting, administrative, and enforcement aspects of the law to state governments. In states with the authority to implement CWA programs, the EPA still retains oversight responsibilities.

In 1972, Congress enacted the first comprehensive national clean water legislation in response to growing public concern for serious and widespread water pollution. The Clean Water Act is the primary federal law that protects our nation's waters, including lakes, rivers, aquifers and coastal areas.

Lake Erie was dying. The Potomac River was clogged with blue-green algae blooms that were a nuisance and a threat to public health. Many of the nation's rivers were little more than open sewers and sewage frequently washed up on shore. Fish kills were a common sight. Wetlands were disappearing at a rapid rate.

Today, the quality of our waters has improved dramatically as a result of a cooperative effort by federal, state, tribal and local governments to implement the pollution control programs established in 1972 by the Clean Water Act.

The Clean Water Act's primary objective is to restore and maintain the integrity of the nation's waters. This objective translates into two fundamental national goals:

- eliminate the discharge of pollutants into the nation's waters, and
- achieve water quality levels that are fishable and swimmable.

The Clean Water Act focuses on improving the quality of the nation's waters. It provides a comprehensive framework of standards, technical tools and financial assistance to address the many causes of pollution and poor water quality. It includes municipal and industrial wastewater discharges, polluted runoff from urban and rural areas, and habitat destruction.



For example, the Clean Water Act requires major industries to meet performance standards to ensure pollution control; charges states and tribes with setting specific water quality criteria

appropriate for their waters and developing pollution control programs to meet them; provides funding to states and communities to help them meet their clean water infrastructure needs; protects valuable wetlands and other aquatic habitats through a permitting process that ensures development and other activities are conducted in an environmentally sound manner. After 25 years, the Act continues to provide a clear path for clean water and a solid foundation for an effective national water program.

### **In 1972**

Only a third of the nation's waters were safe for fishing and swimming. Wetlands losses were estimated at about 460,000 acres annually.

Agricultural runoff resulted in the erosion of 2.25 billion tons of soil and the deposit of large amounts of phosphorus and nitrogen into many waters. Sewage treatment plants served only 85 million people.

### **Today**

Two-thirds of the nation's waters are safe for fishing and swimming.

The rate of annual wetlands losses is estimated at about 70,000-90,000 acres according to recent studies. The amount of soil lost due to agricultural runoff has been cut by one billion tons annually, and phosphorus and nitrogen levels in water sources are down. Modern wastewater treatment facilities serve 173 million people.

### **The Future**

All Americans will enjoy clean water safe for fishing and swimming. We will achieve a net gain of wetlands by preventing additional losses and restoring hundreds of thousands of acres of wetlands. Soil erosion and runoff of phosphorus and nitrogen into watersheds will be minimized, helping to sustain the nation's farming economy and aquatic systems. The nation's waters will be free of effects of sewage discharges.

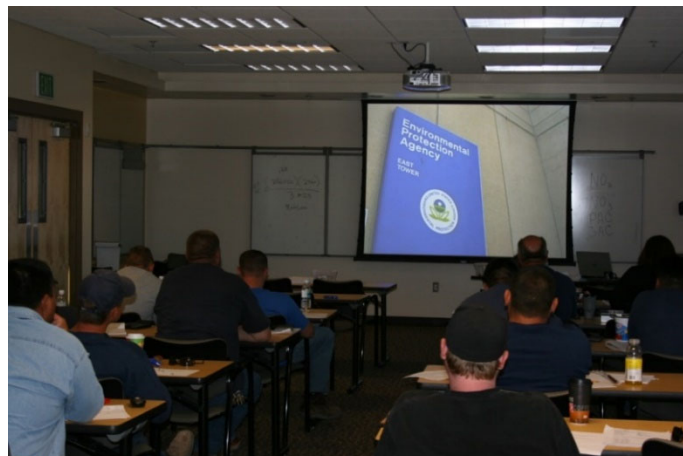

As a collection system worker or septic installer, you will need sewer knowledge, mastery of the Clean Water Act and of your wastewater ordinances.

## Problems that Can Cause Chronic SSOs Include:

**Infiltration and Inflow (I&I):** Too much rainfall or snowmelt infiltrating through the ground into leaky sanitary sewers not designed to hold rainfall or to drain property, and excess water inflowing through roof drains connected to sewers, broken pipes, and badly connected sewer service lines.

**Undersized Systems:** Sewers and pumps are too small to carry sewage from newly-developed subdivisions or commercial areas.

**Pipe Failures:** blocked, broken or cracked pipes, tree roots grow into the sewer, sections of pipe settle or shift so that pipe joints no longer match, and sediment and other material builds up causing pipes to break or collapse.

**Equipment Failures:** Pump failures, power failures.

**Sewer Service Connections:** Discharges occur at sewer service connections to houses and other buildings; some cities estimate that as much as 60% of overflows comes from the service lines.

**Deteriorating Sewer System:** Improper installation, improper maintenance; widespread problems that can be expensive to fix develop over time, some municipalities have found severe problems necessitating billion-dollar correction programs, often communities have to curtail new development until problems are corrected or system capacity is increased.



### Why are SSOs a Problem?

The EPA has found that SSOs caused by poor sewer collection system management pose a substantial health and environmental challenge. The response to this challenge varies considerably from state to state.

Many municipalities have asked for national consistency in the way permits are considered for wastewater discharges, including SSOs, and in enforcement of the law prohibiting unpermitted discharges. In response, the EPA has convened representatives of states, municipalities, health agencies, and environmental advocacy groups to advise the Agency on how to best meet this challenge.

### How Big is the SSO Problem?

The total number of SSOs that occur nationwide each year is not known. In some areas, they might not be reported or are underreported to the EPA and state environmental agencies. Two surveys, however, help to define the size of the problem:

- In a 1994 survey of 79 members of the Association of Metropolitan Sewerage Agencies, 65 percent of the respondents reported wet weather SSOs. They reported that between 15 and 35 percent of their sewers were filled above capacity and/or overflowed during wet weather. However, municipal respondents with SSOs had only limited information about them. Only 60 percent had estimated the annual number. Half of those had estimated the amount of sewerage discharged, and 17 percent had determined what pollutants were in their overflows.

- A 1981 survey conducted by the National Urban Institute indicated an average of 827 backups and 143 breaks per 1,000 miles of sewer pipe (about 1,000 miles of sewer pipe are needed to serve 250,000 people.) per year. Breaks occurred most often in the young, growing cities of the South and West.



Downstream of a nonfunctional Combined Sewer Overflow (CSO) Control Facility.



## Combined Sewer Overflows

Combined sewer systems are sewers that are designed to collect rainwater runoff, domestic sewage, and industrial wastewater in the same pipe. Most of the time, combined sewer systems transport all of their wastewater to a sewage treatment plant, where it is treated and then discharged to a water body. During periods of heavy rainfall or snowmelt, however, the wastewater volume in a combined sewer system can exceed the capacity of the sewer system or treatment plant. For this reason, combined sewer systems are designed to overflow occasionally and discharge excess wastewater directly to nearby streams, rivers, or other water bodies.

These overflows, called combined sewer overflows (CSOs), contain not only storm water but also untreated human and industrial waste, toxic materials, and debris. They are a major water pollution concern for the approximately 772 cities in the U.S. that have combined sewer systems. CSOs may be thought of as a type of "urban wet weather" discharge. This means that, like sanitary sewer overflows (SSOs) and storm water discharges, they are discharges from a municipality's wastewater conveyance infrastructure that are caused by precipitation events such as rainfall or heavy snowmelt. The EPA's CSO Control Policy, published April 19, 1994, is the national framework for control of CSOs.

The Policy provides guidance on how communities with combined sewer systems can meet Clean Water Act goals in as flexible and cost-effective a manner as possible. EPA's Report to Congress on implementation of the CSO Control Policy assesses the progress made by EPA, states, and municipalities in implementing and enforcing the CSO Control Policy.

Proper function of sanitary sewer systems is vital to protect public health, property, and waterways in the surrounding area. Most utilities have a management, operation, and maintenance (MOM) plan to ensure their system is in working order. However, more than 40,000 sanitary sewage overflows SSOs occur every year, causing huge monetary losses, damage to fish/shellfish beds, polluting groundwater, and decreased tourism. Sanitary sewage overflows (SSOs) release raw sewage from the collection system before it can reach a treatment facility. Sewage may flow out of manholes, into businesses and homes, and eventually ends up in local waterways.

Many factors are involved in SSOs. Many municipalities started constructing sewer systems over 100 years ago. Some of these have not been adequately maintained, improved, or repaired over the last century.

Cities have used a wide variety of building materials, designs, and installation techniques, which aren't durable enough to withstand heavy, continuous use. Problems can be especially bad where an older system is attached to a new system or an older system has fallen into disrepair.

EPA believes that every sanitary sewer system has the capacity to have a sanitary sewer overflows (SSO). This may be due to a number of factors including, but not limited to:

- Blockages
- Structural, mechanical, or electrical failures
- Collapsed or broken sewer pipes • Insufficient conveyance capacity

- Vandalism

Additionally, high levels of inflow and infiltration (I/I) during wet weather can cause SSOs. Many collection SSOs include untreated discharges from sanitary sewer systems that reach waters of the United States systems that were designed according to industry standards experience wet weather SSOs because levels of I/I may exceed levels originally expected; prevention of I/I has proven more difficult and costly than anticipated; or the capacity of the system has become inadequate due to an increase in service population without corresponding system upgrades (EPA 2004).

The Management, Operation and Maintenance (MOM) Programs Project is a pilot enforcement approach developed by EPA Region 4 to bring municipal sewer systems into full compliance with the Clean Water Act by eliminating sanitary sewer overflows (SSOs) from municipal sewer systems. A SSO is a release of untreated wastewater before the flow reaches a treatment plant. SSOs pose a significant threat to public health and water quality.

### **Treatment Balance and the Effects of Undesirable Solids**

For any wastewater treatment plant to operate properly, the operator has to maintain a skillfully balanced mixture of microorganisms which contact and digest the organics in the wastewater, and bacteria then grows on this media to treat the wastewater. When a plant is properly maintained these bacteria or bugs eat the dissolved organics in the water, thus removing BOD, Ammonia, Nitrates, and Phosphorus.

All of these constituents must be treated and removed from the water. When this is accomplished you achieve a low turbidity and clean decantible water which is then filtered and chlorinated to kill all the remaining bacteria. This incredible process leaves extremely clean and reusable water that can be injected back into the ground, sent to ponds or used for irrigation.

Certain compounds and undesirable solids, like grease and grass clippings, can disturb this delicate balance and necessary process at the wastewater treatment facility. There are compounds and mixtures that should never be introduced into a sanitary sewer system. These destructive compounds include but are not limited to: cleaning solvents, grease (both household and commercial), oils (both household and commercial), pesticides, herbicides, antifreeze and other automotive products.

The solids include but are not limited to: plastics, rubber goods, grass clippings, metal products such as aluminum foil, beer or soda cans, wood products, glass, paper products such as disposable diapers and sanitary napkins. Items such as these disturb or even kill the delicate balance of microorganisms and bacteria that are needed to treat the wastewater. These will also clog the sanitary sewer causing back-ups and sewer overflows. First, we will examine the damage to equipment and we will finish with resolution methods.

### **Costly Maintenance**

These harmful compounds and solids can also cause equipment damage and create costly and unnecessary repairs, as well as frequent and costly maintenance. Repairs include but are not limited to: SBR Motive Pumps--these should last at least 5 years but are failing after only 2 or 3 years because of material that was placed in the sewer system. In a

recent 2007 study, the cost of repairing these pumps was around \$30,000.00. The replacement of the influent grinder or, "Muffin Monster" after only 3 years of service was nearly \$7,000.00. The cost of frequent maintenance consists of, but is not limited to: the extensive amounts of damaging solids that clog lift stations and damage lift station pumps. These costs have almost doubled in today's costs.

To properly clean a lift station may cost around \$3,000 -10,000 for each time that common problems occur like grass clippings from a golf course, overflowing grease from improperly maintained grease traps from a casino, hotel or golf course and improperly maintained grease and oil interceptors.

These costs do not touch the cost of cleaning the sewer mains and manholes. In most cases, no serious damage will occur to the sewer main or manhole, but the chance of overflowing sewage or untreated wastewater getting to the street is greatly increased and does happen in most communities. Most of us know about it and accept it as part of our jobs. But time and rules have changed. We must work harder and be smarter to stop these problems before the damage and overflow occurs.

### **Municipality Self-Assessment**

Under the MOM Programs Project, municipalities are encouraged to undertake a detailed self-assessment of their MOM programs. The municipalities submit this self-assessment along with recommendations for improvements to the MOM programs and/or remedial measures to correct sewer infrastructure problems.

In consideration for undertaking the self-assessment, the municipality is able to establish its own reasonable goals and schedules, which could result to significantly reduced penalties related to SSOs. Where an enforcement action is necessary, the regulator works with the municipality to identify necessary remedial measures and to establish schedules. The Regulator will likely defer any penalty decision until after the completion of the necessary improvements.

### **Project Initiation**

In 1998, Region 4 began the MOM Programs Project by identifying priority watersheds and geographical areas in each of the eight States in the Region. These included areas where SSOs could cause significant public health concerns, such as beaches, shellfish harvesting areas and drinking water supplies. In addition, watersheds already listed as impaired by collection system overflows or bacterial contamination were identified.

Region 4, working with the States, selected a watershed (or geographical area) in each State. All municipal sewer systems in each watershed were identified and invited to participate in the Project and to attend a kickoff meeting held at a location in the watershed.

Those municipalities wanting to participate in the MOM Project undertake the self-assessment using the guidance materials provided and submit the self-assessment to the Region within seven months of the kickoff. Municipalities that don't participate are inspected by the Region and/or State and are subject to traditional enforcement actions, including penalties where appropriate. Improper management and maintenance cause a majority of avoidable SSOs.

## Leading Causes of SSOs

Problem/Cause	% of SSOs	Description
Blockages	43%	Blockages may be caused by tree roots or a build-up of sediment and other materials (i.e., grease, grit, debris). Structural defects and a flat slope can also cause excessive deposits of material. Build-ups can cause pipes to break or collapse.
Infiltration and Inflow (I/I)	27%	Infiltration and inflow occurs when rain or snowmelt enters the ground and seeps into leaky sanitation sewers, which were not designed to carry rainfall or drain property. Inflow can also occur when excess waters from roof drains, broken pipes and bad connections at sewer service lines infiltrates the sanitary sewer.
Structural Failures	12%	Line/main breaks are a major result of structural failure. Undersized systems do not have large enough pumps or lines to carry all the sewage generated by the buildings attached to them. This is especially true for new subdivisions or commercial areas. SSOs can occur at sewer service connections to houses or buildings. Some cities estimate that up to 60% of SSOs come from service lines.
Power Failure	11%	Stops pump operation, interrupting sewage flow
Other	7%	Scheduling, vandalism



Above, a cracked sewer main, a SSO waiting to happen.

## Purpose of CMOM Programs

CMOM programs incorporate many of the standard operation and maintenance activities that are routinely implemented by the owner or operator with a new set of information management requirements in order to:

- Better manage, operate, and maintain collection systems
- Investigate capacity constrained areas of the collection system
- Proactively prevent SSOs
- Respond to SSO events

The CMOM approach helps the owner or operator provide a high level of service to customers and reduce regulatory noncompliance. CMOM can help utilities optimize use of human and material resources by shifting maintenance activities from “reactive” to “proactive”—often leading to savings through avoided costs due to overtime, reduced emergency construction costs, lower insurance premiums, changes in financial performance goals, and fewer lawsuits.

CMOM programs can also help improve communication relations with the public, other municipal works and regional planning organizations, and regulators. It is important to note that the collection system board members or equivalent entity should ensure that the CMOM program is established as a matter of policy. The program should not be micro-managed, but an understanding of the resources required of the operating staff to implement and maintain the program is necessary. In CMOM planning, the owner or operator selects performance goal targets, and designs CMOM activities to meet the goals.

The CMOM planning framework covers operation and maintenance (O&M) planning, capacity assessment and assurance, capital improvement planning, and financial management planning. Information collection and management practices are used to track how the elements of the CMOM program are meeting performance goals, and whether overall system efficiency is improving. On a periodic basis, utility activities should be reviewed and adjusted to better meet the performance goals. Once the long-term goal of the CMOM program is established, interim goals may be set. For instance, an initial goal may be to develop a geographic information system (GIS) of the system.

Once the GIS is complete, a new goal might be to use the GIS to track emergency calls and use the information to improve maintenance planning. An important component of a successful CMOM program is periodically collecting information on current systems and activities to develop a “snapshot-in-time” analysis. From this analysis, the owner or operator evaluates its performance and plans its CMOM program activities. Maintaining the value of the investment is also important. Collection systems represent major capital investments for communities and are one of the communities’ major capital assets.

Equipment and facilities will deteriorate through normal use and age. Maintaining value of the capital asset is a major goal of the CMOM program. The infrastructure is what produces sales and service. Proper reinvestment in capital facilities maintains the ability to provide service and generate sales at the least cost possible and helps ensure compliance with environmental requirements.

The performance of wastewater collection systems is directly linked to the effectiveness of its CMOM program. Performance characteristics of a system with an inadequate CMOM program include frequent blockages resulting in overflows and backups.

Other major performance indicators include pump station reliability, equipment availability, and avoidance of catastrophic system failures such as a collapsed pipe.

A CMOM program is what an owner or operator should use to manage its assets; in this case, the collection system itself. The CMOM program consists of a set of best management practices that have been developed by the industry and are applied over the entire life cycle of the collection system and treatment plant.

These practices include:

- Designing and constructing for O&M
- Knowing what comprises the system (inventory and physical attributes)
- Knowing where the system is (maps and location)
- Knowing the condition of the system (assessment)
- Planning and scheduling work based on condition and performance
- Repairing, replacing, and rehabilitating system components based on condition and performance
- Managing timely, relevant information to establish and prioritize appropriate CMOM activities

EPA and state NPDES inspectors evaluate collection systems and treatment plants to determine compliance with permit conditions including proper O&M. Among others, these permit conditions are based on regulation in 40 CFR 122.41(e): “The permittee shall at all times properly operate and maintain all facilities and systems of treatment and control (and related appurtenances) which are installed or used by the permittee to achieve compliance with the conditions of this permit.”

When violations occur, the collection system or wastewater treatment plant owner or operator can face fines and requirements to implement programs to compensate residents and restore the environment.

## **The Elements of a Proper CMOM Program**

### **Utility Specific**

The complexity and expense associated with a utility's CMOM or MOM programs is specific to the size and complexity of the Publicly Owned Treatment Works (POTW) and related infrastructure. Factors such as population growth rate and soil/groundwater conditions also dictate the level of investment which should be made.

### **Purposeful**

When MOM programs are present and properly maintained, they support customer service and protect system assets, public health, and water quality.

### **Goal-Oriented**

Proper MOM programs have goals directed toward their individual purposes. Progress toward these goals is measurable, and the goals are attainable.

### **Uses Performance Measures**

Performance measures should be established for each MOM program in conjunction with the program goal. These measures are quantifiable, and used in determining progress to, or beyond, the program goal.

### **Periodically Evaluated**

An evaluation of the progress toward reaching the goals, or a reassessment of the goals, should be made periodically and based upon the quantified performance measures.

### **Available In Writing**

The effectiveness of a MOM program quickly breaks down unless it is available in writing. Personnel turnover and lapses in communication between staff and management can change otherwise proper MOM programs to improper ones. Written MOM programs are useful only if they are made readily available to all personnel and clearly documented.

### **Implemented by Trained Personnel**

Appropriate safety, equipment, technical, and program training is essential for implementing MOM programs properly.

### ***What MOM programs should be audited?***

MOM activity at a utility involves its entire wastewater infrastructure. Common utility management activities and operations and maintenance activities associated with sewer systems and pretreatment are listed in the Self-Audit Review Document.

If a utility owns treatment works or a pond system, then activities associated with the management, operation, and maintenance of these facilities should also be included in the audit. A helpful guide for this part is the NPDES Compliance Inspection Manual. Instruction for obtaining this manual is provided in a list of references.

### ***What are the elements of a proper Self-Audit?***

#### **Initial Assessment**

Begin by performing a general assessment of the utility, and prioritizing the order of programs to be audited. The NPDES Compliance Inspection Manual and Guidance may be useful references in making this assessment.

**Develop the Audit Plan**

Identify the MOM programs present and/or needed at the utility, establish performance measures, and develop a schedule for auditing the programs.

**Conduct the Audit**

Evaluate each MOM program against the defined elements of a proper program. This can be accomplished by reviewing the program's records and resources, conducting a field evaluation, and comparing the program understanding of both personnel and management.

**Identify Deficiencies**

Define any programs needed, or improvements to programs needed, and any infrastructure deficiencies found. Identify any unpermitted discharges that have occurred in the past five years.

**Develop Improvement Plan**

Define the utility's plan/schedule to remediate the necessary improvements. This plan should include any short-term or long-term program improvements, and any short-term or long-term capital improvements that need addressing.

**Prepare the Self-Audit Report**

Generate a report of the audit results, including any deficiencies found and the corresponding improvement plan, which is useful for the utility. This report should be capable of serving the utility as a reference when conducting any needed remedial measures, and as a reference to compare current performance with future self-audit results.

***Are there federal grants or other compliance assistance resources available to conduct a Self-Audit?***

Currently, there are no funds available for the specific purpose of conducting a MOM Programs Self-Audit. However, the Office of Wastewater Management offers a number of financial resources to assist qualified utilities in making improvements to their programs.

Small publicly-owned wastewater treatment plants which discharge less than 5 million gallons per day are also eligible for the Wastewater Treatment Plant Operator On-Site Assistance Training Program. The program provides on-site operator training, financial management, troubleshooting, and other operation and maintenance assistance. A network of operator training personnel, EPA Regional Office Coordinators and States and State Training Centers work in the field with small under-served communities to help solve their operation and maintenance problems. There is no cost incurred by the facility in need of assistance. The only requirement of the program is the willingness to work with a trainer to correct the facility's problems.

**What Health Risks do SSOs present?**

Because SSOs contain raw sewage they can carry bacteria, viruses, protozoa (parasitic organisms), helminths (intestinal worms), and borroughs (inhaled molds and fungi). The diseases they may cause range in severity from mild gastroenteritis (causing stomach cramps and diarrhea) to life-threatening ailments such as cholera, dysentery, infectious hepatitis, and severe gastroenteritis.



### **People can be Exposed Through:**

- Sewage in drinking water sources.
- Direct contact in areas of high public access such as basements, lawns or streets, or waters used for recreation. At least one study has estimated a direct relationship between gastrointestinal illness contracted while swimming and bacteria levels in the water.
- Shellfish harvested from areas contaminated by raw sewage. One study indicates that an average of nearly 700 cases of illness per year were reported in the 1980s from eating shellfish contaminated by sewage and other sources. The number of unreported cases is estimated to be 20 times that.
- Some cases of disease contracted through inhalation and skin absorption have also been documented.

### **What other Damage can SSOs do?**

SSOs also damage property and the environment. When basements flood, the damaged area must be thoroughly cleaned and disinfected to reduce the risk of disease. Cleanup can be expensive for homeowners and municipalities. Rugs, curtains, flooring, wallboard panels, and upholstered furniture usually must be replaced. A key concern with SSOs that enter oceans, bays, estuaries, rivers, lakes, streams, or brackish waters is their effect on water quality. When bodies of water cannot be used for drinking water, fishing, or recreation, society experiences an economic loss. Tourism and waterfront home values may fall. Fishing and shellfish harvesting may be restricted or halted. SSOs can also close beaches. One 1994 study claims that SSOs closed beaches across the nation that year for a total of more than 300 days.

### **How can SSOs be Reduced or Eliminated?**

Many avoidable SSOs are caused by inadequate or negligent operation or maintenance, inadequate system capacity, and improper system design and construction. These SSOs can be reduced or eliminated by:

- Sewer system cleaning and maintenance
- Reducing infiltration and inflow through system rehabilitation and repairing broken or leaking service lines.
- Enlarging or upgrading sewer, pump station, or sewage treatment plant capacity and/or reliability.
- Construction of wet weather storage and treatment facilities to treat excess flows.

Communities also should address SSOs during sewer system master planning and facilities planning, or while extending the sewer system into previously unsewered areas. A few SSOs may be unavoidable. Unavoidable SSOs include those occurring from unpreventable vandalism, some types of blockages, extreme rainstorms, and acts of nature such as earthquakes or floods.

### **What Costs are Involved with Reducing or Eliminating SSOs?**

Sanitary sewer collection systems are a valuable part of the nation's infrastructure. The EPA estimates that our nation's sewers are worth a total of more than \$1 trillion. The collection system of a single large municipality is an asset worth billions of dollars and that of a smaller city could cost many millions to replace.

Sewer rehabilitation to reduce or eliminate SSOs can be expensive, but the cost must be weighed against the value of the collection system asset and the added costs if this asset is allowed to further deteriorate. Ongoing maintenance and rehabilitation adds value to the original investment by maintaining the system's capacity and extending its life. The costs of rehabilitation and other measures to correct SSOs can vary widely by community size and sewer system type.

Those being equal, however, costs will be highest and ratepayers will pay more in communities that have not put together regular preventive maintenance or asset protection programs. Assistance is available through the Clean Water Act State Revolving Fund for capital projects to control SSOs. State Revolving Funds in each state and Puerto Rico can help arrange low-interest loans. For the name of your State Revolving Fund contact, please call the EPA Office of Water Resource Center, (202) 566-1729.

To reduce sanitary sewer overflows (SSOs), the EPA is proposing to clarify and expand permit regulations that are already in force under the Clean Water Act. This will affect over 19,000 municipal sanitary sewer systems, including 4800 satellite collection systems that will be regulated for the first time. It will allow streamlined CMOM requirements for small communities, and permit them to skip self-audits and annual reports if an SSO hasn't occurred.

**More Specifically, CMOM will Require Facilities to:**

- Establish general performance standards.
- Have a management program.
- Create an overflow response plan.
- Ensure system evaluations.
- Verify capacity assurance.
- Submit to periodic audits of the CMOM program.
- Notify the public and regulatory agencies of SSOs.

**General Performance Standards**

A CMOM program will ensure:

- There is enough capacity to handle base and peak flows.
- The use of all reasonable measure to stop SSOs.
- Proper collection, management, operation and maintenance of the system.
- Prompt notification of all parties that may be exposed to an SSO.

**Management Programs**

Management program documents must include:

- The goals of the CMOM program (may differ depending on the facility.)
- Legal authorities that will help implement CMOM.
- The "chain of command" for implementing CMOM and reporting SSOs.
- Design and performance requirements.
- Measures that will be taken to help implement CMOM.
- Monitoring/performance measures to how effective the CMOM program is.
- Communication plan.

**Overflow Response Plan**

The overflow response plan should be designed provide a quick response to SSOs. Rapid response to an SSO can mitigate structural damage, pollution of waterways, and the public health risk. The plan must include the following:

- SSO response procedures.
- Immediate notification of health officials.
- Public notification.
- Plan made available to the public.
- Distribution to all appropriate personnel.
- Revision and maintenance of the plan by appropriate personnel.

## Collection System Management

Collection system management activities form the backbone for operation and effective maintenance activities. The goals of a management program should include:

- Protection of public health and prevention of unnecessary property damage
- Minimization of infiltration, inflow and exfiltration, and maximum conveyance of wastewater to the wastewater treatment plant
- Provision of prompt response to
- Staffing plans—Number of people and service interruptions
- Efficient use of allocated funds
- Sewer use ordinance
- Identification of and remedy solutions to design, construction, and operational deficiencies
- Performance of all activities in a safe manner to avoid injuries

Without the proper procedures, management and training systems, O&M activities may lack organization and precision, resulting in a potential risk to human health and environmental contamination of surrounding water bodies, lands, dwellings, or groundwater. The following sections discuss the common elements of a robust collection system management program.

### Organizational Structure

Well-established organizational structure, which delineates responsibilities and authority for each position, is an important component of a CMOM program for a collection system. This information may take the form of an organizational chart or narrative description of roles and responsibilities, or both. The organizational chart should show the overall personnel structure, including operation and maintenance staff. Additionally, up-to-date job descriptions should be available.

Job descriptions should include the nature of the work performed, the minimum requirements for the position, the necessary special qualifications or certifications, examples of the types work, lists of licenses required for the position, performance measures or promotion potential. Other items to note in regard to the organizational structure are the percent of staff positions currently vacant, on average, the length of time positions remain vacant, and the percent of collection system work that is contracted out.

### Reviewer - Point to Note

The reviewer may want to note the turnover rate and current levels of staffing (i.e., how many vacant positions exist and for how long they have been vacant). This may provide some indication of potential understaffing, which can create response problems. Reviewers should evaluate specific qualifications of personnel and determine if the tasks designated to individuals, crews, or teams match the job descriptions and training requirements spelled out in the organizational structure.

From an evaluation standpoint, the reviewer might try to determine what type of work is performed by outside contractors and what specific work is reserved for collection system personnel. If much of the work is contracted, it is appropriate to review the contract and to look at the contractor's capabilities.

If the contractor handles emergency response, the reviewer should examine the contract with the owner or operator to determine if the emergency response procedures and requirements are outlined. The inclusion of job descriptions in the organizational structure ensures that all employees know their specific job responsibilities and have the proper credentials.

Additionally, it is useful in the course of interviews to discuss staff management. The reviewer should note whether staff receive a satisfactory explanation of their job descriptions and responsibilities. In addition, when evaluating the CMOM program, job descriptions will help a reviewer determine who should be interviewed.

### **Reviewer - Point to Note**

A reviewer should look for indications that responsibilities are understood by employees. Such indications may include training programs, meetings between management and staff, or policies and procedures.

When evaluating the organizational structure, the reviewer should look for the following:

- Except in very small systems, operation and maintenance personnel ideally should report to the same supervisor or director. The supervisor or director should have overall responsibility for the collection system. Guide for Evaluating CMOM Programs at Sanitary Sewer Collection Systems
- In some systems, maintenance may be carried out by a citywide maintenance organization, which may also be responsible for such diverse activities as road repair and maintenance of the water distribution system. This can be an effective approach, but only if adequate lines of responsibility and communication are established.
- In general, one supervisor should manage a team of individuals small enough that is safe and effective. However, the individuals on the team may have additional employees reporting to them. This prevents the top supervisors from having to track too many individuals. The employee-supervisor ratio at individual collection systems will vary depending on their need for supervisors. In a utility with well-established organizational structure, staff and management should be able to articulate their job and position responsibilities.

Personnel should be trained to deal with constantly changing situations and requirements, both regulatory and operational. The system's personnel requirements vary in relation to the overall size and complexity of the collection system. In very small systems, these responsibilities may include operation of the treatment plant as well as the collection system.

In many systems, collection system personnel are responsible for the stormwater as well as wastewater collection system. References providing staff guidelines or recommendations are available to help the reviewer determine if staffing is adequate for the collection system being reviewed.

## Potential Performance Indicators

Input measures	Per capita costs Number of employee hours
Output measures	Length of pipe maintained Number of service calls completed Percentage of length maintained repaired this year Percentage of length maintained needing repair Length of new sewer constructed Number of new services connected
Outcomes	Number of stoppages per 100 miles of pipe Average service response time Number of complaints
Ecological/Human health/ Resource use	Shellfish bed closures Benthic Organism index Biological diversity index Beach closures Recreational activities Commercial activities

### CMOM Audits

CMOM will require regular, comprehensive audits, done by each facility. These audits will help identify non-conformance to CMOM regulations so problems can be addressed quickly. All findings, proposed corrective actions and upcoming improvements should be documented in the audit report.

### Communication/Notification

If an SSO occurs, sanitary sewer facilities will be required to immediately notify the NPDES permit authority, appropriate health agencies, state authorities, drinking water suppliers, and, if necessary, the general public in the risk area. This rule will also require an annual report of all overflows, including minor SSOs such as building backups. Facilities must post locations of recurrent SSOs and let the public know that the annual report is available to them. The record keeping provisions mandate that facilities must maintain records for three years about all overflows, complaints, work orders on the system, and implementation measures.

### According to the EPA, an effective CMOM program would help NPDES permittees to:

- Develop/revise routine preventive maintenance activities that prevent service interruption and protect capital investments.
- Create an inspection schedule and respond to the inspection results.
- Investigate the causes of SSOs and take corrective measures.
- Respond quickly to SSOs to minimize impacts to human health and the environment.
- Identify and evaluate SSO trends.
- Develop budgets and identify staffing needs.
- Plan for future growth to ensure adequate capacity is available when it's needed.

- Identify hydraulic (capacity) and physical deficiencies and prioritize responses, including capital investments.
- Identify and develop appropriate responses to program deficiencies (e.g., lack of legal authority, inadequate funding, and inadequate preventive maintenance).
- Keep parts and tools inventories updated and equipment in working order.
- Report and investigate safety incidents and take steps to prevent their recurrence.

### **Implementation**

The EPA estimates that implementing this rule will impose an additional \$93.5 to \$126.5 million every year on municipalities (includes planning and permitting costs). A system serving 7,500 people may need to spend an average of \$6,000 every year to comply with the rule.

CMOM regulations will be added to the permit when facilities need to have a permit re-issued. Although a compliance deadline has not been set, the EPA recommends that facilities begin to implement “SSO Standard Conditions” right after the proposed rule is published. Considering the time and costs associated with compliance, this may be good advice.

### **Continuous Training**

Procedures for emergency response plans should be understood and practiced by all personnel in order to ensure safety of the public and the collection system personnel responding. Procedures should be specific to the type of emergency that could occur.

It is important to keep detailed records of all past emergencies in order to constantly improve response training, as well as the method and timing of future responses.

The ability to deal with emergencies depends on the knowledge and skill of the responding crews, in addition to availability of equipment. The crew should be able to rapidly diagnose problems in the field under stress and select the right equipment needed to correct the problem.

If resources are limited, consideration should be given to contracting other departments or private industries to respond to some emergencies, for example, those rare emergencies that would exceed the capacity of staff.

### **System Evaluation and Capacity Assurance Plan**

These two activities work hand-in-hand to detect and address deficiencies and scheduling. These will provide:

- An evaluation of parts of the collection system that have substandard performance.
- Capacity assurance measures to address substandard performance.
- Explanation of prioritization and scheduling.

Performance measures and indicators are important in evaluating collection system performance and implementing capacity management, operation and maintenance programs.

## Hydrogen Sulfide Monitoring and Control Sub-Section

The collection system owner or operator should have a program under which they monitor areas of the collection system that may be vulnerable to the adverse effects of hydrogen sulfide. It may be possible to perform visual inspections of these areas. The records should note such items as the condition of metal components, the presence of exposed rebar (metal reinforcement in concrete), copper sulfate coating on copper pipes and electrical components, and loss of concrete from the pipe crown or walls.

### Areas Subject to Generation of Hydrogen Sulfide:

- Sewers with low velocity conditions and/or long detention times
- Sewers subject to solids deposition
- Pump stations
- Turbulent areas, such as drop manholes or force main discharge points
- Inverted siphon discharges

The collection system owner or operator should be carrying out routine manhole inspections. The hydrogen sulfide readings generated as a result of these inspections should be added to the records of potential areas of corrosion. A quick check of the pH of the pipe crown or structure enables early indication of potential hydrogen sulfide corrosion. A pH of less than four indicates further investigation is warranted. "Coupons" may be installed in structures or pipelines believed to be potentially subject to corrosion. Coupons are small pieces of steel inserted into the area and measured periodically to determine whether corrosion is occurring.

### Reviewer - Point to Note

The reviewer should be aware that a system in which infiltration and inflow (I/I) has successfully been reduced may actually face an increased risk of corrosion. The reviewer should pay particular attention to the hydrogen sulfide monitoring program in these systems.

The reduction of flow through the pipes allows room for hydrogen sulfide gases to rise into the airway portion of the sewer pipe and react with the bacteria and moisture on the pipe walls to form sulfuric acid. Sulfuric acid corrodes ferrous metals and concrete. There are several methods to prevent or control hydrogen sulfide corrosion. The first is proper design. Design considerations are beyond the scope of this manual but may be found in the Design Manual: Odor and Corrosion Control in Sanitary Sewerage Systems and Treatment Plants (EPA 1985).

The level of dissolved sulfide in the wastewater may also be reduced by chemical or physical means such as aeration, or the addition of chlorine, hydrogen peroxide, potassium permanganate, iron salts, or sodium hydroxide. Whenever chemical control agents are used, the owner or operator should have procedures for their application and maintain records of the dosages of the various chemicals.

Alternatively, sewer cleaning to remove deposited solids reduces hydrogen sulfide generation. Also, air relief valves may be installed at the high points of the force main system. The valve allows air to exit thus avoiding air space at the crown of the pipe where acid can form. The reviewer should examine the records to see that these valves are receiving periodic maintenance.

Collection systems vary widely in their vulnerability to hydrogen sulfide corrosion. Vitrified clay and plastic pipes are very resistant to hydrogen sulfide corrosion while concrete, steel, and iron pipes are more susceptible. The physical aspects of the collection system are also important.

Sewage in pipes on a decline that moves the wastewater at a higher velocity will have less hydrogen sulfide than sewage in pipes where the wastewater may experience longer detention times. Therefore, some systems may need a more comprehensive corrosion control program while some might limit observations to vulnerable points.

### **Safety**

The reasons for development of a safety program should be obvious for any collection system owner or operator. The purpose of the program is to define the principles under which the work is to be accomplished, to make the employees aware of safe working procedures, and to establish and enforce specific regulations and procedures. The program should be in writing (e.g., procedures, policies, and training courses) and training should be well documented. The purpose of safety training is to stress the importance of safety to employees. Safety training can be accomplished through the use of manuals, meetings, posters, and a safety suggestion program.

One of the most common reasons for injury and fatalities in wastewater collection systems is the failure of victims to recognize hazards. Safety training cuts across all job descriptions and should emphasize the need to recognize and address hazardous situations.

### **Safety programs should be in place for the following areas:**

- Confined spaces
- Chemical handling
- Trenching and excavations
- Safety Data Sheets (SDS)
- Biological hazards in wastewater
- Traffic control and work site safety
- Lockout/Tagout
- Electrical and mechanical safety
- Pneumatic or hydraulic systems safety

The collection system owner or operator should have written procedures that address all of the above issues and are made available to employees. In addition to training, safety programs should incorporate procedures to enforce the program.

For example, this could include periodic tests or “pop” quizzes to monitor performance and/or compliance and follow-up on safety related incidents. The owner or operator should maintain all of the safety equipment necessary for system staff to perform their daily activities and undertake any emergency repairs.

### **This equipment should include, at minimum:**

- Atmospheric gas testing equipment
- Respirators and/or self-contained breathing apparatus
- Full body harness
- Tripods or non-entry rescue equipment
- Hard hats



- Safety glasses
- Rubber boots
- Rubber and/or disposable gloves
- Antibacterial soap
- First aid kit
- Protective clothing
- Confined space ventilation equipment
- Traffic and/or public access control equipment
- Hazardous gas meter

### **Reviewer - Point to Note**

The reviewer should, in the course of interviewing personnel, determine their familiarity with health and safety procedures according to their job description. Each field crew vehicle should have adequate health and safety supplies. If the reviewer has access to the municipal vehicle storage area, he or she might choose to check actual vehicle stocks, not just supplies in storage.

### **Confined Space Safety**

Collection system operators typically assist with manhole cover removal and other physical activities. The inspector should refrain from entering confined spaces. A confined space is defined by the Occupational Safety and Health Administration (OSHA) as a space that:

- (1) is large enough and so configured that an employee can bodily enter and perform assigned work; and
- (2) has limited or restricted means for entry or exit; and
- (3) is not designed for continuous employee occupancy

### **[29 CFR 1910.146(b)].**

A “permit-required confined space (permit space)” is a confined space that has one or more of the following characteristics:

- (1) contains or has a potential to contain a hazardous atmosphere;
- (2) contains a material that has the potential for engulfing an entrant;
- (3) has an internal configuration such that an entrant could be trapped or asphyxiated by inwardly converging walls or by a floor which slopes downward and tapers to a smaller cross-section; or
- (4) contains any other recognized serious safety or health hazard [29 CFR 1910.146(b)].

Though OSHA has promulgated standards for confined spaces, those standards do not apply directly to municipalities, except in those states that have approved plans and have asserted jurisdiction under Section 18 of the OSHA Act.

Contract operators and private facilities do have to comply with the OSHA requirements and the inspector may find that some municipalities elect to do so voluntarily. In sewer collection systems, the two most common confined spaces are the underground pumping station and manholes.

The underground pumping station is typically entered through a relatively narrow metal or concrete shaft via a fixed ladder. Inspectors conducting the field evaluation component of the CMOM audit should be able to identify and avoid permit-required confined spaces.

Although most confined spaces are unmarked, confined spaces that may have signage posted near their entry containing the following language:

**DANGER—PERMIT REQUIRED—CONFINED SPACE AUTHORIZED PERSONNEL ONLY**

If confined space entry is absolutely necessary, inspectors should consult with the collection system owner or operator first, have appropriate training on confined space entry, and use the proper hazard detection and personal safety equipment.

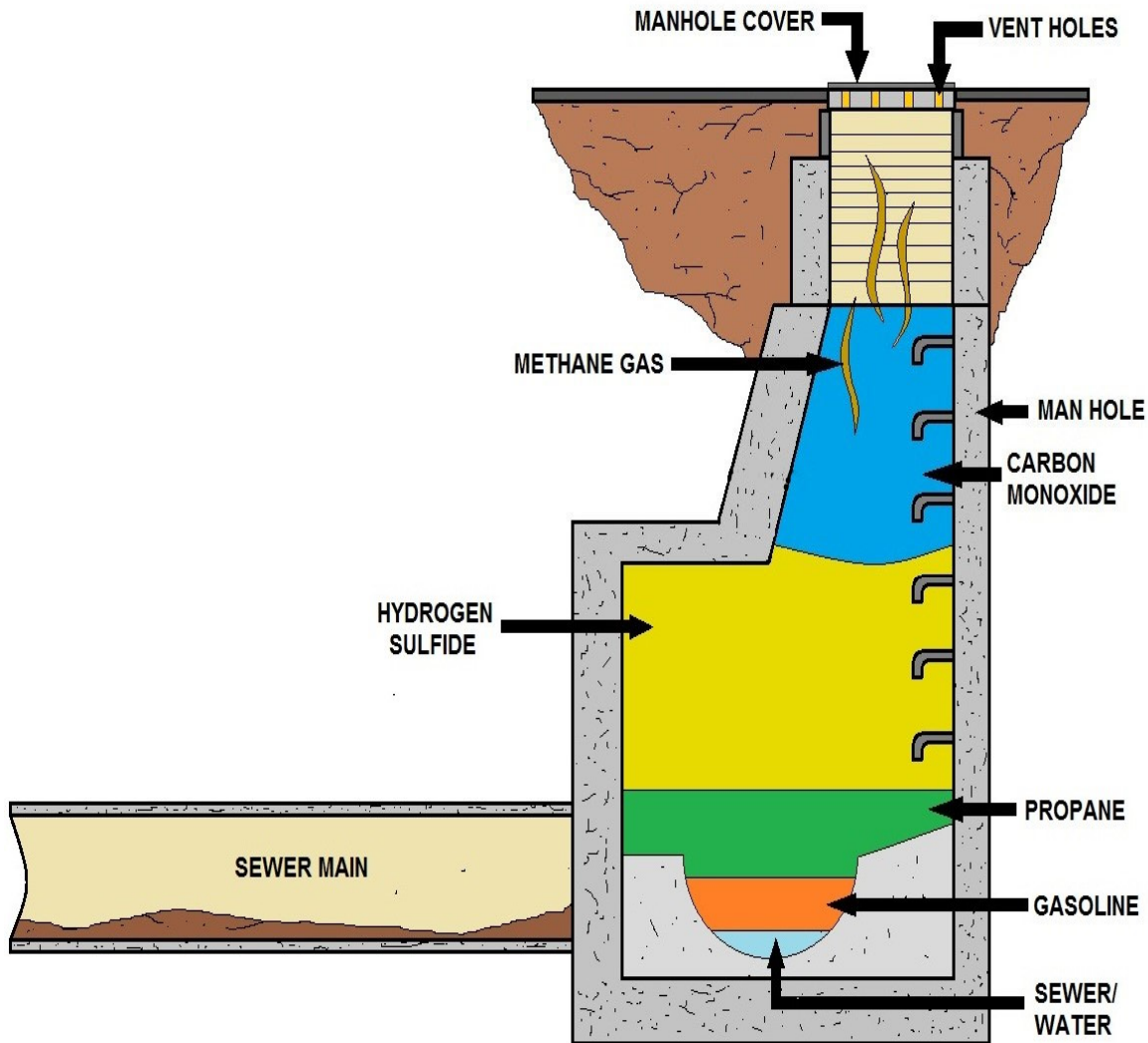

**POSSIBLE HAZARDOUS ATMOSPHERES PRESENT IN A CONFINED SPACE  
(EXAMPLE IS OF A SEWER MAIN)**

## CMOM Summary

Sewers deteriorate over time and develop cracks, breaks and blockages if not properly maintained. Aging, out-of-sight, out-of-mind sewer systems can be neglected and thus not be inspected or maintained on a regular basis. A CMOM Program is an effective, holistic management tool that owners of collection systems (primarily municipalities) create to operate and manage a collection system to significantly reduce, if not eliminate, sanitary sewer overflows and basement backups. It assures sewage collection system owners proactively operate and maintain this significant and valuable community infrastructure through planned ongoing maintenance and prioritizing rehabilitation and replacement projects.

For EPA and state inspectors or other reviewers, conducting an evaluation of collection system CMOM programs shares many similarities with other types of compliance reviews. Overall, the reviewer would examine records, interview staff and conduct field investigations, generally in that order although tailored, if necessary, to meet site-specific needs.

Prior to performing the onsite interviews and evaluations, preliminary information may be requested that will provide an overall understanding of the organization to allow for a more focused approach for the review. This information also provides a basis for more detailed data gathering during on site activities. The information typically requested prior to the review should include a schematic map of the collection system (could be as-built drawings) and any written operations or maintenance procedures. Depending on the volume of information, the collection system owner or operator may need ample lead time to gather and copy these documents.

Alternatively, the reviewer may offer to examine the documents and bring them back when doing the on-site review so that extra copies are not necessary. No matter which method is used, the importance of up-front preparation cannot be overemphasized. With the exception of pump stations and manholes, much of the collection system is not visible. Therefore, the more complete the reviewer's understanding of the system is prior to the review, the more successful the assessment will be. The reviewer would then proceed with the on-site activities.

Guidance for conducting compliance reviews is provided in the NPDES Compliance Inspection Manual (EPA 2004). The manual provides the general procedures for performing compliance reviews and is a valuable source of information on such topics as entry, legal authority, and responsibilities of the reviewer. Although CMOM evaluations are not specifically addressed in the manual, the general review procedures can be applied to CMOM reviews. Another good reference for general review information is the Multi-Media Investigations Manual, NEIC (EPA 1992). Some issues with entry are specific to CMOM reviews.

Some facilities may be on private property and the reviewer may need property owner consent for entry.

### **Documents to Review On-site Include:**

- Organization chart(s)
- Staffing plans

- Job descriptions
- Sewer use ordinance
- Overall map of system showing facilities such as pump stations, treatment plants, major gravity sewers, and force mains
- O&M budget with cost centers for wastewater collection
- Performance measures for inspections, cleaning, repair, and rehabilitation
- Recent annual report, if available
- Routine reports regarding system O&M activities
- Collection system master plan
- Capital improvement projects (CIP) plan
- Flow records or monitoring
- Safety manual
- Emergency response plan
- Management policies and procedures
- Detailed maps/schematics of the collection system and pump stations
- Work order management system
- O&M manuals
- Materials management program
- Vehicle management and maintenance records
- Procurement process
- Training plan for employees
- Employee work schedules
- Public complaint log
- Rate ordinance or resolution
- Financial report (“notes” section)
- As built plans
- Discharge monitoring reports (DMRs)

Field reviews are typically conducted after interviews. The following is a list of typical field sites the team should visit:

- Mechanical and electrical maintenance shop(s)
- Fleet maintenance facilities (vehicles and other rolling stock)
- Materials management facilities (warehouse, outside storage yards)
- Field maintenance equipment storage locations (i.e., crew trucks, mechanical and hydraulic cleaning equipment, construction and repair equipment, and television inspection equipment)
- Safety equipment storage locations
- Pump stations
- Dispatch and supervisory control and data acquisition (SCADA) systems
- Crew and training facilities
- Chemical application equipment and chemical storage areas (use of chemicals for root and grease control, hydrogen sulfide control [odors, corrosion])
- Site of SSOs, if applicable
- A small, but representative, selection of manholes

## Pretreatment Preface (*Credit USEPA*)

The industrial boom in the United States during the 1950s and 60s brought with it a level of pollution never before seen in this country. Scenes of dying fish, burning rivers, and thick black smog engulfing major metropolitan areas were images and stories repeated regularly on the evening news. In December of 1970, the President of the United States created the U.S. Environmental Protection Agency (EPA) through an executive order in response to these critical environmental problems.

In 1972, Congress passed the Clean Water Act (CWA) to restore and maintain the integrity of the nation's waters. Although prior legislation had been enacted to address water pollution, those previous efforts were developed with other goals in mind. For example, the 1899 Rivers and Harbors Act protected navigational interests while the 1948 Water Pollution Control Act and the 1956 Federal Water Pollution Control Act merely provided limited funding for State and local governments to address water pollution concerns on their own.

The CWA required the elimination of the discharge of pollutants into the nation's waters and the achievement of fishable and swimmable water quality levels. The EPA's National Pollutant Discharge Elimination System (NPDES) Permitting Program represents one of the key components established to accomplish this feat.

The NPDES program requires that all point source discharges to waters of the U.S. (i.e., "*direct discharges*") must be permitted. To address "*indirect discharges*" from industries to Publicly Owned Treatment Works (POTWs), the EPA, through CWA authorities, established the National Pretreatment Program as a component of the NPDES Permitting Program. The National Pretreatment Program requires industrial and commercial dischargers to treat or control pollutants in their wastewater prior to discharge to POTWs.

In 1986, more than one-third of all toxic pollutants entered the nation's waters from publicly owned treatment works (POTWs) through industrial discharges to public sewers. Certain industrial discharges, such as slug loads, can interfere with the operation of POTWs, leading to the discharge of untreated or inadequately treated wastewater into rivers, lakes, etc. Some pollutants are not compatible with biological wastewater treatment at POTWs and may pass through the treatment plant untreated.

This "pass through" of pollutants impacts the surrounding environment, occasionally causing fish kills or other detrimental alterations of the receiving waters. Even when POTWs have the capability to remove toxic pollutants from wastewater, these toxins can end up in the POTW's sewage sludge, which in many places is land applied to food crops, parks, or golf courses as fertilizer or soil conditioner.

The National Pretreatment Program is unique in that the General Pretreatment Regulations require all large POTWs (i.e., those designed to treat flows of more than 5 million gallons per day) and smaller POTWs with significant industrial discharges to establish local pretreatment programs.

These local programs must enforce all national pretreatment standards and requirements in addition to any more stringent local requirements necessary to protect site-specific conditions at the POTW.

More than 1,500 POTWs have developed and are implementing local pretreatment programs designed to control discharges from approximately 30,000 significant industrial users. Since 1983, the Pretreatment Program has made great strides in reducing the discharge of toxic pollutants to sewer systems and to waters of the U.S. In the eyes of many, the Pretreatment Program, implemented as a partnership between the EPA, States, and POTWs, is a notable success story in reducing impacts to human health and the environment. These strides can be attributed to the efforts of many Federal, State, local, and industrial representatives who have been involved with developing and implementing the various aspects of the Pretreatment Program.

The EPA has supported the Pretreatment Program through development of numerous guidance manuals. The EPA has released more than 30 manuals that provide guidance to the EPA, States, POTWs, and industry on various pretreatment program requirements and policy determinations. Through the EPA's guidance, the Pretreatment Program has maintained national consistency in interpretation of the regulations. Nevertheless, turnover in pretreatment program staff has diluted historical knowledge, leaving new staff and other interested parties unaware of existing materials.

- (1) provide a reference for anyone interested in understanding the basics of pretreatment program requirements, *and*
- (2) provide a roadmap to additional and more detailed guidance materials for those trying to implement specific elements of the Pretreatment Program.

While the Pretreatment Program has demonstrated significant reductions in pollutants discharged to POTWs, Congress' goals of zero discharge of toxic pollutants and fishable/swimmable water quality have not been realized. The EPA is currently working to establish more cost-effective and common sense approaches to environmental protection (e.g., using watershed, streamlining, and reinvention concepts), creating new responsibilities for all those involved in the National Pretreatment Program. Many current challenges remain, while many new ones likely lie ahead.

This course is intended to provide an understanding of the basic concepts that drive the Program, the current status of the Program and program guidance, and an insight into what the future holds for all those involved with implementing the Pretreatment Program.



Two lab techs examine various samples, including QA/QC and Trip Blanks to ensure both sample integrity and lab equipment/sample equipment quality.

## Post Quiz

### Purpose of CMOM Programs

1. The CMOM approach helps the owner or operator provide a high level of service to customers and reduce \_\_\_\_\_.
2. Once the GIS is complete, a new goal might be to use the GIS to track emergency calls and use the information to improve \_\_\_\_\_.
3. In CMOM planning, the owner or operator selects \_\_\_\_\_ targets, and designs CMOM activities to meet the goals.
4. Information collection and management practices are used to track how the elements of the CMOM program are meeting \_\_\_\_\_, and whether overall system efficiency is improving.
5. An important component of a \_\_\_\_\_ is periodically collecting information on current systems and activities to develop a “snapshot-in-time” analysis. From this analysis, the owner or operator evaluates its performance and plans its CMOM program activities.
6. Performance characteristics of a system with an inadequate CMOM program include frequent blockages resulting in \_\_\_\_\_.
7. Other major performance indicators include pump station reliability, equipment availability, and avoidance of \_\_\_\_\_ such as a collapsed pipe.

### The Elements of a Proper CMOM Program

#### Purposeful

8. \_\_\_\_\_ when present and properly maintained, they support customer service and protect system assets, public health, and water quality.

#### Goal-Oriented

9. \_\_\_\_\_ have goals directed toward their individual purposes. Progress toward these goals is measurable, and the goals are attainable.

#### Uses Performance Measures

10. Performance measures should be established for each of this \_\_\_\_\_ in conjunction with the program goal.

**Periodically Evaluated**

11. An evaluation of the progress toward reaching the goals, or \_\_\_\_\_, should be made periodically and based upon the quantified performance measures.

**Available In Writing**

12. The effectiveness of a MOM program quickly breaks down unless it is available in writing. Personnel turnover and lapses in communication between staff and management can change otherwise proper MOM programs to improper ones.

A. True      B. False

**Implemented by Trained Personnel**

13. Appropriate safety, equipment, technical, and program training is essential for implementing?

**What MOM programs should be audited?**

14. \_\_\_\_\_ at a utility involves its entire wastewater infrastructure. Common utility management activities and operations and maintenance activities associated with sewer systems and pretreatment are listed in the Self-Audit Review Document?

15. If a utility owns treatment works or a pond system, then activities associated with the management, operation, and maintenance of these facilities should be included in the audit.

A. True      B. False

**Identify Deficiencies**

16. Identify any permitted discharges that have occurred in the past seven years.

A. True      B. False

**Develop Improvement Plan**

17. Define the utility's plan/schedule to remediate the?

**Prepare the Self-Audit Report**

18. \_\_\_\_\_ including any deficiencies found and the corresponding improvement plan, which is useful for the utility?

**Answers**

1. Regulatory noncompliance, 2. Maintenance planning, 3. Performance goal, 4. Performance goals, 5. Successful CMOM program, 6. Overflows and backups, 7. Catastrophic system failures, 8. MOM programs, 9. Proper MOM programs, 10. MOM program, 11. A reassessment of the goals, 12. True, 13. MOM program(s), 14. MOM activity, 15. True, 16. False, 17. Necessary improvements, 18. Audit results



## Chapter 8 – PUMPS AND LIFT STATIONS SECTION

**Section Focus:** You will learn the Clean Water Act and the basics of the wastewater collection pumping or lift stations. At the end of this section, you the student will be able to describe the basics of the pumping station system. There is a post quiz at the end of this section to review your comprehension and a final examination in the Assignment for your contact hours.

**Scope/Background:** In many systems, a lift or pumping station is a major component of lifting wastewater to the onsite facility. Sewer pipes are generally gravity driven. Wastewater flows slowly downhill until it reaches a certain low point. Then, pump or "lift" stations push the wastewater back uphill to a high point where gravity can once again take over the process.



**Lift Station:** A facility in a sewer system consisting of a receiving chamber, pumping equipment, and associated drive and control devices which collect and lift wastewater to a higher elevation when the continuance of the sewer at reasonable slopes would involve excessive trench depths; or that collects and raises wastewater through the use of force mains from areas too low to drain into available sewers. There should not be an odor coming from a Lift Station.

**Pumping Station:** A relatively large sewage pumping installation designed not only to lift sewage to a higher elevation, but also to convey it through force mains to gravity flow points located relatively long distances from the pumping station.

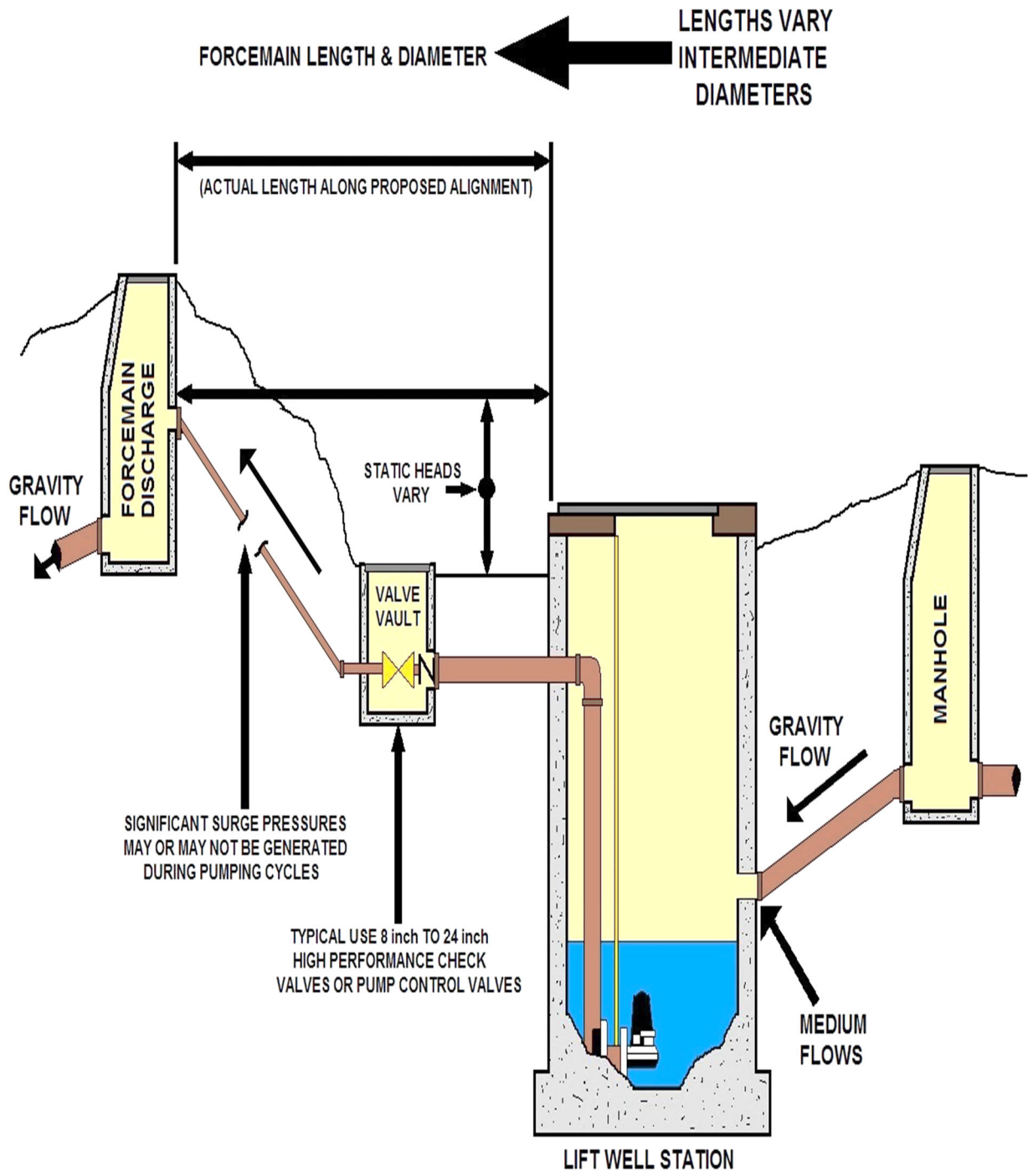

**MEDIUM SEWAGE LIFT STATION  
TYPICAL CHARACTERISTICS**

## Lift Stations – Wet Well/Dry Well Introduction

Sewer pipes are generally gravity driven. Wastewater flows slowly downhill until it reaches a certain low point. Then, pump or "lift" stations push the wastewater back uphill to a high point where gravity can once again take over the process.

Lift stations are used in sanitary sewer systems where water is accumulated in wet wells and then pumped to a higher elevation. They are generally designed to operate continuously to keep sewerage from backing up through the system. That means that most lift stations have a backup electrical supply in the event that normal power is disrupted.

Most wastewater collection/onsite systems will have installed radio/WIFI telemetry, or SCADA systems. The telemetry system is used to monitor and control pump stations via computer at the WW collections facility.

This type of system gives up to the minute pump station status such as wet well level, pump performance, electrical power conditions, etc. This allows wastewater technicians to prevent wastewater spills and protect public health. Using telemetry, Operators have the ability to identify potential problems instantaneously and take the proper steps to rectify the situation before it becomes a public health risk.

### A Lift Station typically contains 4 main Components:

- A wet well - usually 15+ ft. in depth and 8ft. in diameter - that houses two submersible pumps (there are some stations with up to 5 submersibles) of varying horsepower, discharging piping and floats that operate the pumps and keep a set level in the well.
- A dry well that houses the piping and valves that prevent backflow in the station, and camlock connection used to bypass the submersibles in an emergency.
- An electrical panel houses control for the submersible pumps. It also houses the telemetry used to monitor and control the station remotely.
- A "Log Book" or "Station Book" which contains the records and maps of the Lift Station's area.

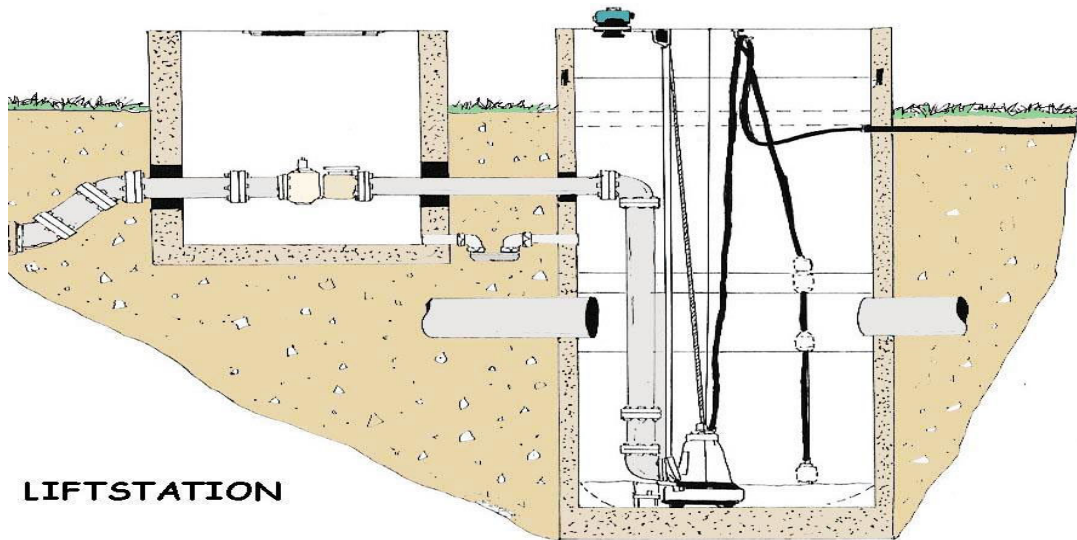

## Common Hydraulic Terms

### Head

The height of a column or body of fluid above a given point expressed in linear units. Head is often used to indicate gauge pressure. Pressure is equal to the height times the density of the liquid.

### Head, Friction

The head required to overcome the friction at the interior surface of a conductor and between fluid particles in motion. It varies with flow, size, type, and conditions of conductors and fittings, and the fluid characteristics.

### Head, Static

The height of a column or body of fluid above a given point.

### Hydraulics

Engineering science pertaining to liquid pressure and flow.

### Hydrokinetics

Engineering science pertaining to the energy of liquid flow and pressure.

### Pascal's Law

A pressure applied to a confined fluid at rest is transmitted with equal intensity throughout the fluid.

### Pressure

The application of continuous force by one body upon another that it is touching; compression. Force per unit area, usually expressed in pounds per square inch (Pascal or bar).

### Pressure, Absolute

The pressure above zone absolute, i.e. the sum of atmospheric and gauge pressure. In vacuum related work it is usually expressed in millimeters of mercury. (mmHg).

### Pressure, Atmospheric

Pressure exerted by the atmosphere at any specific location. (Sea level pressure is approximately 14.7 pounds per square inch absolute, 1 bar = 14.5psi.)

### Pressure, Gauge

Pressure differential above or below ambient atmospheric pressure.

### Pressure, Static

The pressure in a fluid at rest.

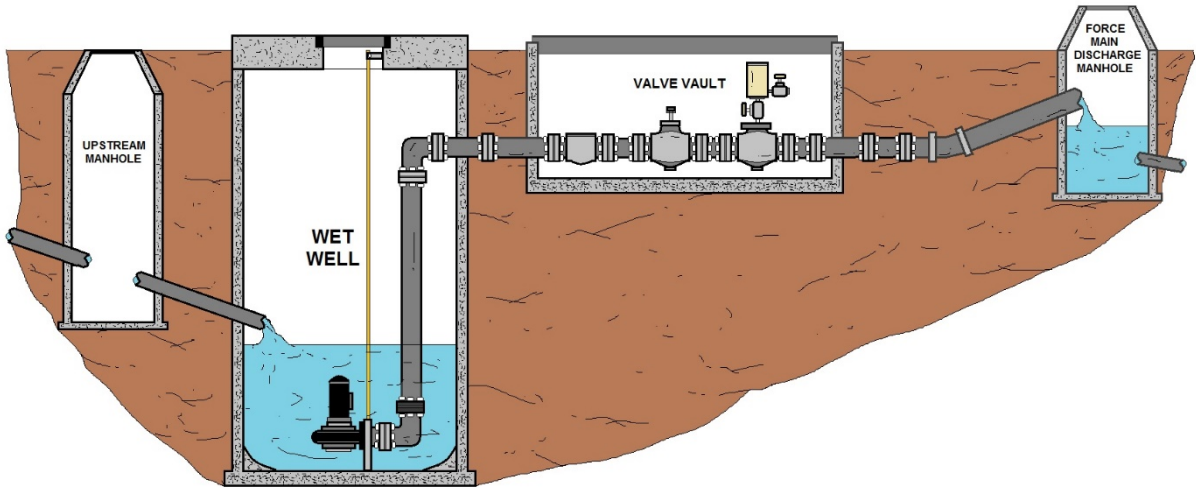

**LIFT STATION (SMALL)**

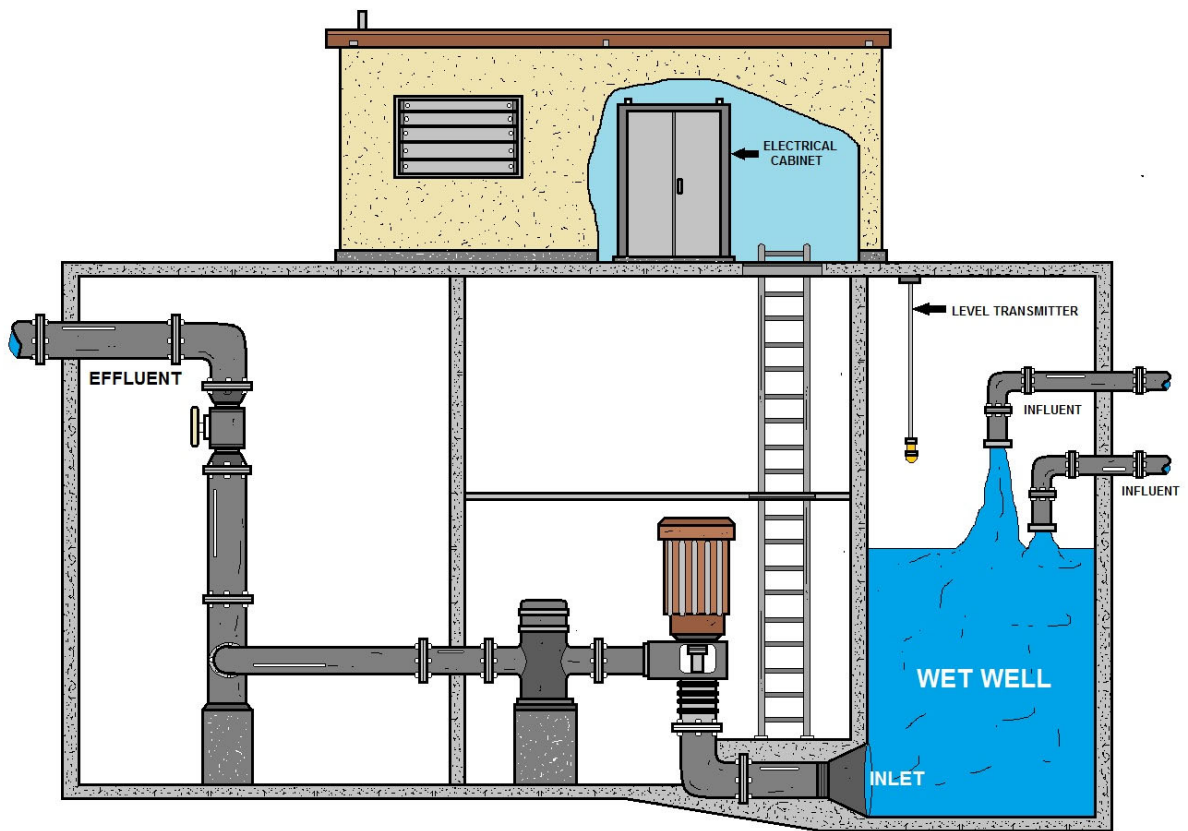

**LIFT STATION (Large)**

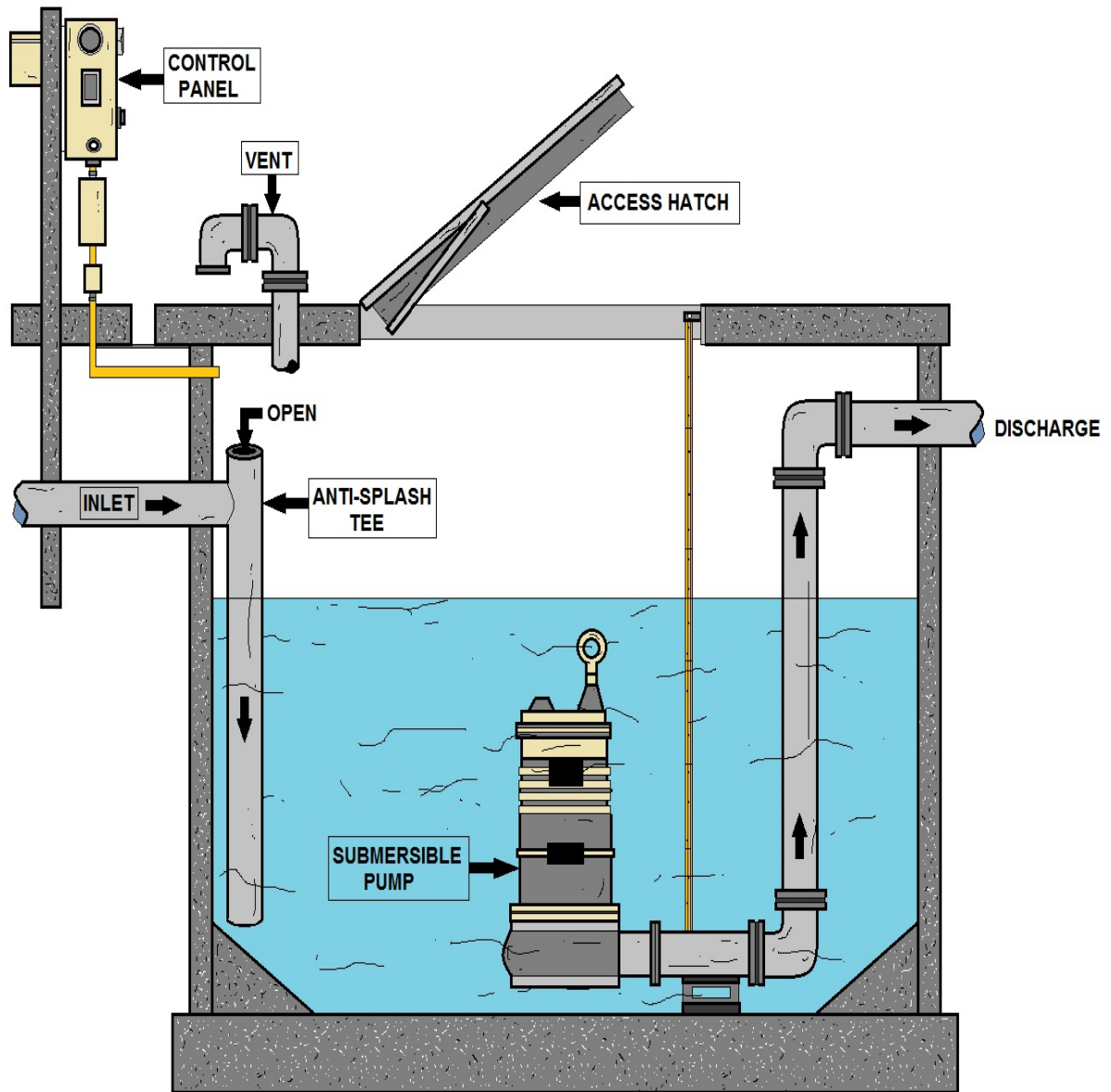

**SMALL PUMPING STATION**



## Hydraulic/Electrical Analogy Principles Sub-Section

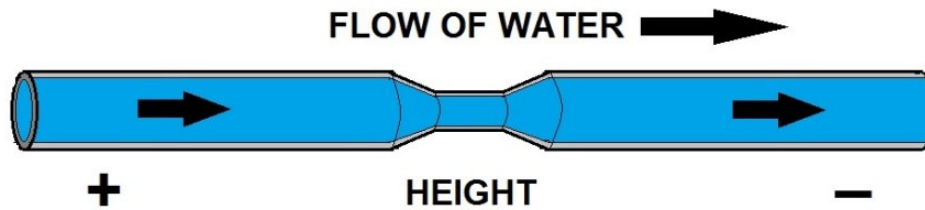

**Electricity flow can be compared to flow of water:**

- When pressure is applied at one end of a pipe (or wire) then, water (or electricity) will come out the other end.

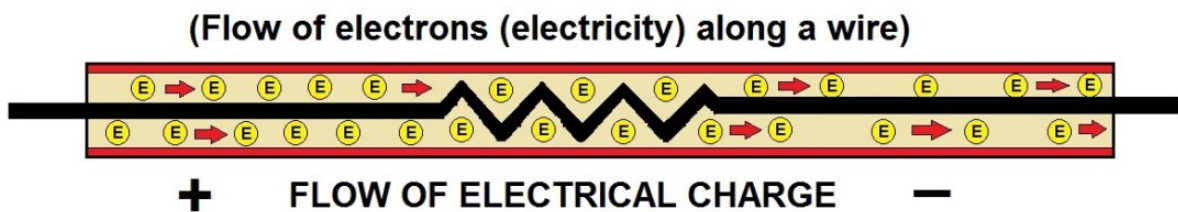

### BASIC ELECTRICAL CONCEPT DIAGRAM

## Water (Hydraulic) and Electrical Principles Are Very Similar

The electronic–**hydraulic analogy** (derisively referred to as the **drain-pipe theory** by Oliver Heaviside) is the most widely used analogy for "electron fluid" in a metal conductor. Since electric current is invisible and the processes at play in electronics are often difficult to demonstrate, the various electronic components are represented by hydraulic equivalents.

Electricity (as well as heat) was originally understood to be a kind of fluid, and the names of certain electric quantities (such as current) are derived from hydraulic equivalents. As all analogies, it demands an intuitive and competent understanding of the baseline paradigms (electronics and hydraulics).

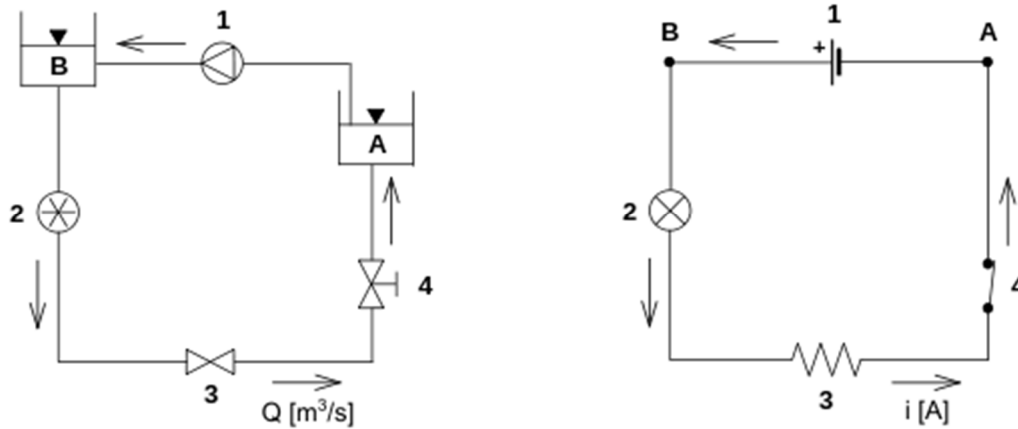

Analogy between a hydraulic circuit (left) and an electronic circuit (right).

### Basic Hydraulic Ideas

There are two basic paradigms:

- Version with pressure induced by gravity. Large tanks of water are held up high, or are filled to differing water levels, and the potential energy of the water head is the pressure source. This is reminiscent of electrical diagrams with an up arrow pointing to +V, grounded pins that otherwise are not shown connecting to anything, and so on.
- Completely enclosed version with pumps providing pressure only; no gravity. This is reminiscent of a circuit diagram with a voltage source shown and the wires actually completing a circuit.

**Applications:** Flow and pressure variables can be calculated in fluid flow network with the use of the hydraulic ohm analogy. The method can be applied to both steady and transient flow situations.



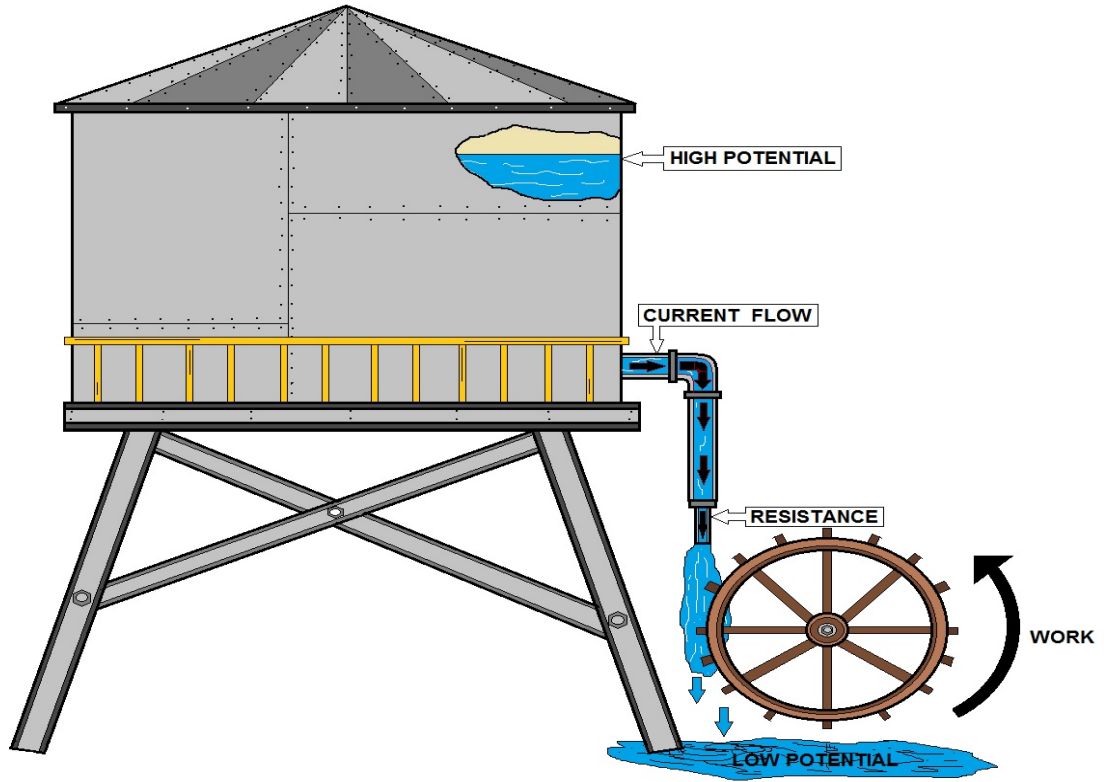

**WATER FLOWS LIKE ELECTRICITY**

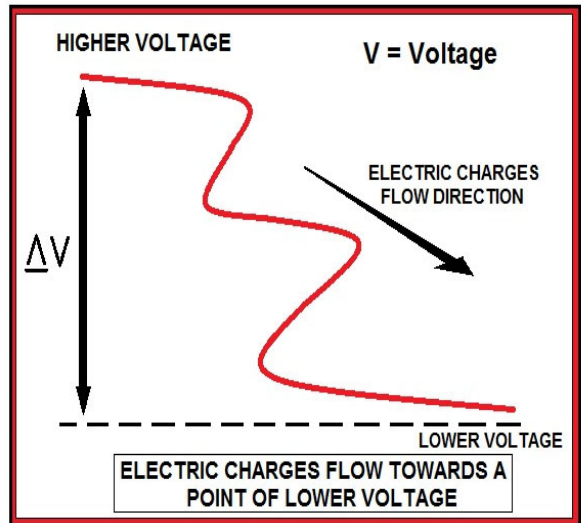
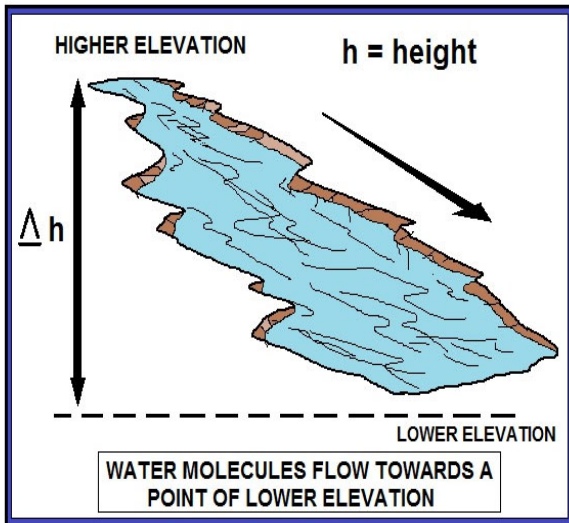

**WATER FLOWS LIKE ELECTRICITY EXAMPLE**

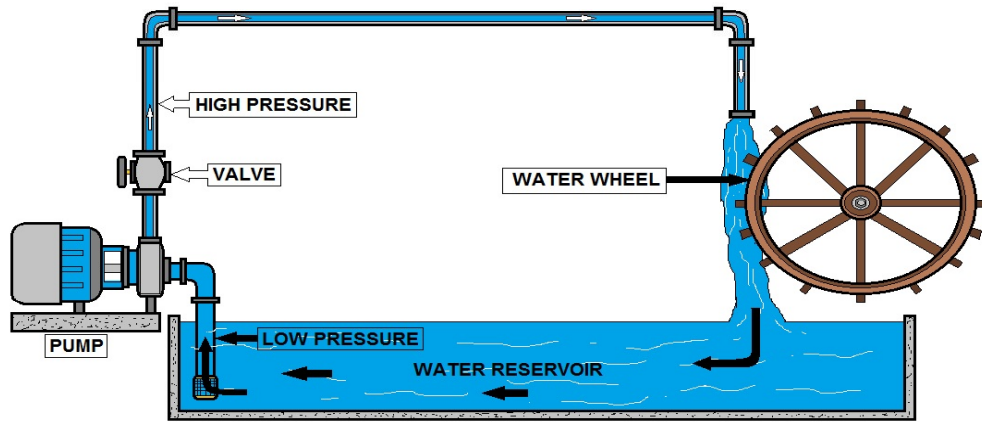
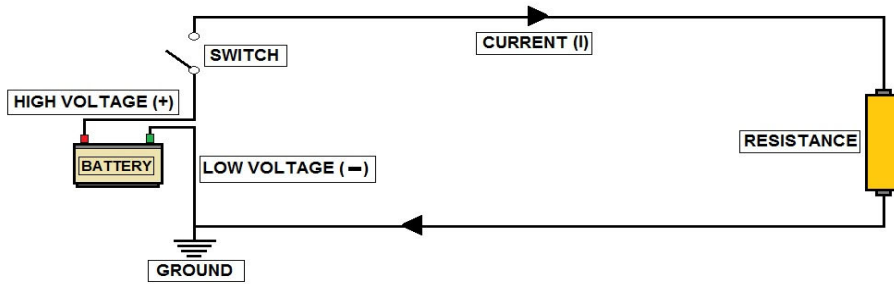

Technical Learning College

EXAMPLE OF HOW WATER FLOWS SIMILAR TO ELECTRICITY

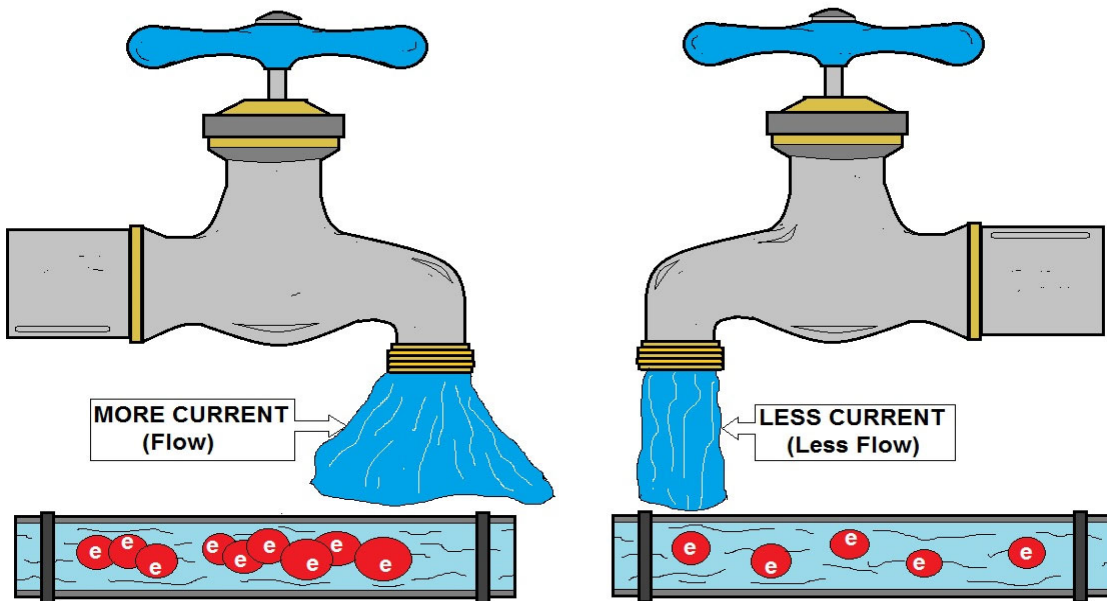

Technical Learning College

ELECTRIC CURRENT - WATER ANALOGY

## Hydraulic Component Equivalents

### Wires

A relatively wide pipe completely filled with water is equivalent to a piece of wire. When comparing to a piece of wire, the pipe should be thought of as having semi-permanent caps on the ends. Connecting one end of a wire to a circuit is equivalent to forcibly un-capping one end of the pipe and attaching it to another pipe. With few exceptions (such as a high-voltage power source), a wire with only one end attached to a circuit will do nothing; the pipe remains capped on the free end, and thus adds nothing to the circuit.

### Electric potential

In general, it is equivalent to hydraulic head. In this article, it is assumed that the water is flowing horizontally, so that the force of gravity can be ignored, and then electric potential is equivalent to pressure.

### Voltage

Also called voltage drop or *potential difference*. A difference in pressure between two points. Usually measured in volts.

### Electric charge

Equivalent to a quantity of water.

### Current

Equivalent to a hydraulic volume flow rate; that is, the volumetric quantity of flowing water over time. Usually measured in amperes.

### Ideal voltage source, or ideal battery

A dynamic pump with feedback control. A pressure meter on both sides shows that regardless of the current being produced, this kind of pump produces constant pressure difference. If one terminal is kept fixed at ground, another analogy is a large body of water at a high elevation, sufficiently large that the drawn water does not affect the water level.

### Ideal current source

A positive displacement pump. A current meter (little paddle wheel) shows that when this kind of pump is driven at a constant speed, it maintains a constant speed of the little paddle wheel.

### Resistor

A constriction in the bore of the pipe which requires more pressure to pass the same amount of water. All pipes have some resistance to flow, just as all wires have some resistance to current.

### Capacitor

A tank with one connection at each end and a rubber sheet dividing the tank in two lengthwise (a hydraulic accumulator). When water is forced into one pipe, equal water is simultaneously forced out the other pipe, yet no water can penetrate the rubber diaphragm. Energy is stored by the stretching of the rubber. As more current flows "through" the capacitor, the back-pressure (voltage) becomes greater, thus current "leads" voltage in a capacitor. As the back-pressure from the stretched rubber approaches the applied pressure, the current becomes

less and less. Thus capacitors "filter out" constant pressure differences and slowly varying, low-frequency pressure differences, while allowing rapid changes in pressure to pass through.

Note that the device described will pass all changes in pressure "through" equally well, regardless of rate of change, just as an electrical capacitor will. Any device in series must obey (electrical) Kirchhoff's Current Law, or its hydraulic equivalent. Considering the "filter" action, a better and more exact analogy is the hydraulic accumulator "pressure tank", as described, but with a closed, pressurized air bladder and only one water connection. Such accumulators are commonly used in hydraulic power systems exactly for the purpose of damping out pressure surges and "hammers" due to valves opening and closing.

### **Inductor**

A heavy paddle wheel placed in the current. The mass of the wheel and the size of the blades restrict the water's ability to rapidly change its rate of flow (current) through the wheel due to the effects of inertia, but, given time, a constant flowing stream will pass mostly unimpeded through the wheel, as it turns at the same speed as the water flow. The mass and surface area of the wheel and its blades are analogous to inductance, and friction between its axle and the axle bearings corresponds to the resistance that accompanies any non-superconducting inductor.

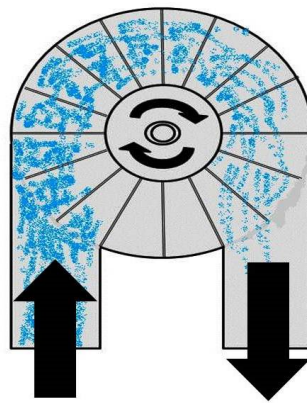

**TURBINE INDUCTOR PADDLE**

Inductors are analogous to a heavy paddle wheel/turbine placed in the current.

An alternative inductor model is simply a long pipe, perhaps coiled into a spiral for convenience. This fluid-inertia device is used in real life as an essential component of a hydraulic ram. The inertia of the water flowing through the pipe produces the inductance effect; inductors "filter out" rapid changes in flow, while allowing slow variations in current to be passed through. The drag imposed by the walls of the pipe is somewhat analogous to parasitic resistance.

In either model, the pressure difference (voltage) across the device must be present before the current will start moving, thus in inductors voltage "leads" current. As the current increases, approaching the limits imposed by its own internal friction and of the current that the rest of the circuit can provide, the pressure drop across the device becomes lower and lower.

**Diode**

Equivalent to a one-way check valve with a slightly leaky valve seat. As with a diode, a small pressure difference is needed before the valve opens. And like a diode, too much reverse bias can damage or destroy the valve assembly.

**Transistor**

A valve in which a diaphragm, controlled by a low-current signal (either constant current for a BJT or constant pressure for a FET), moves a plunger which affects the current through another section of pipe.

**CMOS**

A combination of two MOSFET transistors. As the input pressure changes, the pistons allow the output to connect to either zero or positive pressure.

**Memristor**

A needle valve operated by a flow meter. As water flows through in the forward direction, the needle valve restricts flow more; as water flows the other direction, the needle valve opens further providing less resistance.

**Hydraulic - Electrical Principle Equivalents****EM Wave Speed (velocity of propagation)**

Speed of sound in water. When a light switch is flipped, the electric wave travels very quickly through the wires.

**Charge Flow Speed (drift velocity)**

Particle speed of water. The moving charges themselves move rather slowly.

**DC**

Constant flow of water in a circuit of pipe.

**Low Frequency AC**

Water oscillating back and forth in a pipe.

**Higher-Frequency AC and Transmission Lines**

Sound being transmitted through the water pipes: Be aware that this does not properly mirror the cyclical reversal of alternating electric current. As described, the fluid flow conveys pressure fluctuations, but fluids "do not" reverse at high rates in hydraulic systems, which the above "low frequency" entry does accurately describe. A better concept (if sound waves are to be the phenomenon) is that of direct current with high-frequency "ripple" superimposed.

**Inductive Spark**

Used in induction coils, similar to water hammer, caused by the inertia of water.

## Hydraulic Equation Examples

Some examples of equivalent electrical and hydraulic equations:

type	hydraulic	electric	thermal	mechanical
quantity	volume $V$ [ $\text{m}^3$ ]	charge $q$ [C]	heat $Q$ [J]	momentum $P$ [Ns]
potential	pressure $P$ [ $\text{Pa}=\text{J}/\text{m}^3$ ]	potential $\phi$ [ $\text{V}=\text{J}/\text{C}$ ]	temperature $T$ [ $\text{K}=\text{J}/k_B$ ]	velocity $v$ [m/s]
flux	Volumetric flow rate $\Phi_V$ [ $\text{m}^3/\text{s}$ ]	current $I$ [ $\text{A}=\text{C}/\text{s}$ ]	heat transfer rate $\dot{Q}$ [J/s]	force $F$ [N]
flux density	velocity $v$ [m/s]	current density $j$ [ $\text{C}/(\text{m}^2 \cdot \text{s}) = \text{A}/\text{m}^2$ ]	heat flux $\dot{Q}''$ [ $\text{W}/\text{m}^2$ ]	stress $\sigma$ [ $\text{N}/\text{m}^2 = \text{Pa}$ ]
linear model	Poiseuille's law $\Phi_V = \frac{\pi r^4}{8\eta} \frac{\Delta p^*}{\ell}$	Ohm's law $j = -\sigma \nabla \phi$	Fourier's law $\dot{Q}'' = \kappa \nabla T$	Dashpot $\sigma = c \Delta v$

If the differential equations have the same form, the response will be similar.

## Limits to the Hydraulic Analogy

If taken too far, the water analogy can create misconceptions. For it to be useful, we must remain aware of the regions where electricity and water behave very differently.

### Fields (Maxwell equations, Inductance)

Electrons can push or pull other distant electrons via their fields, while water molecules experience forces only from direct contact with other molecules. For this reason, waves in water travel at the speed of sound, but waves in a sea of charge will travel much faster as the forces from one electron are applied to many distant electrons and not to only the neighbors in direct contact. In a hydraulic transmission line, the energy flows as mechanical waves through the water, but in an electric transmission line the energy flows as fields in the space surrounding the wires, and does not flow inside the metal. Also, an accelerating electron will drag its neighbors along while attracting them, both because of magnetic forces.

### Charge

Unlike water, movable charge carriers can be positive or negative, and conductors can exhibit an overall positive or negative net charge. The mobile carriers in electric currents are usually electrons, but sometimes they are charged positively, such as  $H^+$  ions in proton conductors or holes in p-type semiconductors and some (very rare) conductors.

### Leaking Pipes

The electric charge of an electrical circuit and its elements is usually almost equal to zero, hence it is (almost) constant. This is formalized in Kirchhoff's current law, which does not have an analogy to hydraulic systems, where amount of the liquid is not usually constant. Even with incompressible liquid the system may contain such elements as pistons and open pools, so the volume of liquid contained in a part of the system can change. For this reason, continuing electric currents require closed loops rather than hydraulics' open source/sink resembling spigots and buckets.

#### **James Thurber spoke of his maternal grandmother thus:**

*She came naturally by her confused and groundless fears, for her own mother lived the latter years of her life in the horrible suspicion that electricity was dripping invisibly all over the house. - My Life and Hard Times (1933).*

### Fluid Velocity and Resistance of Metals

As with water hoses, the carrier drift velocity in conductors is directly proportional to current. However, water only experiences drag via the pipes' inner surface, while charges are slowed at all points within a metal. Also, typical velocity of charge carriers within a conductor is less than centimeters per minute, and the "electrical friction" is extremely high. If charges ever flowed as fast as water can flow in pipes, the electric current would be immense, and the conductors would become incandescently hot and perhaps vaporize.

To model the resistance and the charge-velocity of metals, perhaps a pipe packed with sponge, or a narrow straw filled with syrup, would be a better analogy than a large-diameter water pipe. Resistance in most electrical conductors is a linear function: as current increases, voltage drop increases proportionally (Ohm's Law). Liquid resistance in pipes is not linear with volume, varying as the square of volumetric flow (see Darcy–Weisbach equation).

## Quantum Mechanics

Conductors and insulators contain charges at more than one discrete level of atomic orbit energy, while the water in one region of a pipe can only have a single value of pressure. For this reason there is no hydraulic explanation for such things as a battery's charge pumping ability, a diode's voltage drop, solar cell functions, Peltier effect, etc., however equivalent devices can be designed which exhibit similar responses, although some of the mechanisms would only serve to regulate the flow curves rather than to contribute to the component's primary function.

Usefulness requires that the reader or student has a substantial understanding of the model (hydraulic) system's principles. It also requires that the principles can be transferred to the target (electrical) system. Hydraulic systems are deceptively simple: the phenomenon of pump cavitation is a known, complex problem that few people outside of the fluid power or irrigation industries would understand. For those who do, the hydraulic analogy is amusing, as no "cavitation" equivalent exists in electrical engineering. The hydraulic analogy can give a mistaken sense of understanding that will be exposed once a detailed description of electrical circuit theory is required.

One must also consider the difficulties in trying to make the analogy work. The above "electrical friction" example, where the hydraulic analog is a pipe filled with sponge material, illustrates the problem: the model must be increased in complexity beyond any realistic scenario.

## Electrical Measurements and Equipment

Molecule of liquid  $\longrightarrow$  electron of electricity

Flow rate (gpm)  $\longrightarrow$  current (ampere) I, A

Pressure (psi)  $\longrightarrow$  potential (V)

Pressure drop  $\longrightarrow$  voltage drop

Pump  $\longrightarrow$  generator



## Fluid/Hydraulic Forces & Pressures Introduction

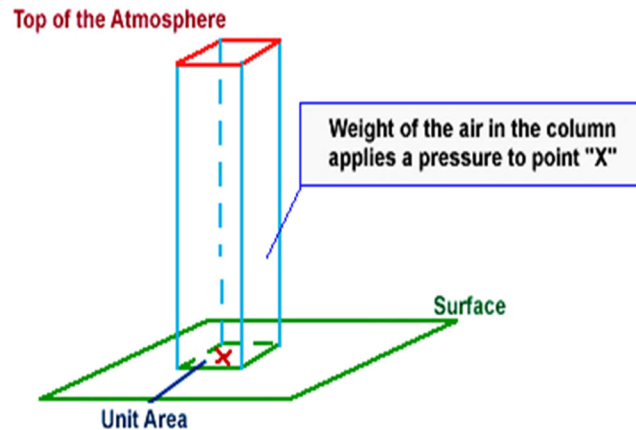

In the diagram, the pressure at point "X" increases as the weight of the air above it increases. The same can be said about decreasing pressure, where the pressure at point "X" decreases if the weight of the air above it also decreases.

### Atmospheric Pressure

The atmosphere is the entire mass of air that surrounds the earth. While it extends upward for about 300 miles, the section of primary interest is the portion that rests on the earth's surface and extends upward for about 7 1/2 miles. This layer is called the troposphere.

If a column of air 1-inch square extending all the way to the "top" of the atmosphere could be weighed, this column of air would weigh approximately 14.7 pounds at sea level. Thus, atmospheric pressure at sea level is approximately 14.7 psi.

As one ascends, the atmospheric pressure decreases by approximately 1.0 psi for every 2,343 feet. However, below sea level, in excavations and depressions, atmospheric pressure increases. Pressures under water differ from those under air because the weight of the water must be added to the pressure of the air.

Atmospheric pressure can be measured by any of several methods. The common laboratory method uses the mercury column barometer. The height of the mercury column serves as an indicator of atmospheric pressure. At sea level and at a temperature of 0° Celsius (C), the height of the mercury column is approximately 30 inches, or 76 centimeters. This represents a pressure of approximately 14.7 psi. The 30-inch column is used as a reference standard.

Another device used to measure atmospheric pressure is the aneroid barometer. The aneroid barometer uses the change in shape of an evacuated metal cell to measure variations in atmospheric pressure. The thin metal of the aneroid cell moves in or out with the variation of pressure on its external surface. This movement is transmitted through a system of levers to a pointer, which indicates the pressure.

The atmospheric pressure does not vary uniformly with altitude. It changes very rapidly. Atmospheric pressure is defined as the force per unit area exerted against a surface by the weight of the air above that surface.

## Fluid and Pressure

By a fluid, we have a material in mind like water or air, two very common and important fluids. Water is incompressible, while air is very compressible, but both are fluids. Water has a definite volume; air does not. Water and air have low viscosity; that is, layers of them slide very easily on one another, and they quickly change their shapes when disturbed by rapid flows.

Other fluids, such as molasses, may have high viscosity and take a long time to come to equilibrium, but they are no less fluids. The coefficient of viscosity is the ratio of the shearing force to the velocity gradient. Hydrostatics deals with permanent, time-independent states of fluids, so viscosity does not appear.

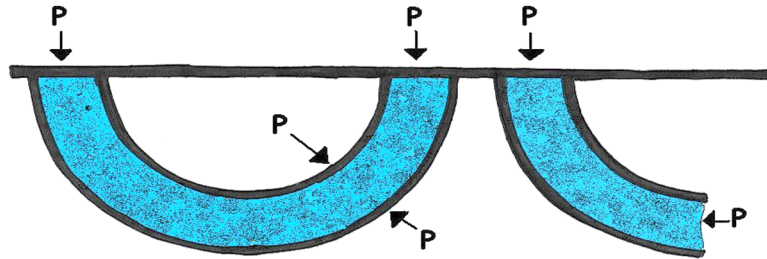

**EQUALITY OF PRESSURE –CURTIAN RINGS DIAGRAM**

## Pressure Definition

A fluid, therefore, is a substance that cannot exert any permanent forces tangential to a boundary. Any force that it exerts on a boundary must be normal perpendicular to the boundary. Such a force is proportional to the area on which it is exerted, and is called a pressure.

We can imagine any surface in a fluid as dividing the fluid into parts pressing on each other, as if it were a thin material membrane, and so think of the pressure at any point in the fluid, not just at the boundaries.

In order for any small element of the fluid to be in equilibrium, the pressure must be the same in all directions (or the element would move in the direction of least pressure), and if no other forces are acting on the body of the fluid, the pressure must be the same at all neighboring points.

## Pascal's Principle

Therefore, in this case the pressure will be the same throughout the fluid, and the same in any direction at a point (Pascal's Principle). Pressure is expressed in units of force per unit area such as dyne/cm<sup>2</sup>, N/cm<sup>2</sup> (pascal), pounds/in<sup>2</sup> (psi) or pounds/ft<sup>2</sup> (psf). The axiom that if a certain volume of fluid were somehow made solid, the equilibrium of forces would not be disturbed, is useful in reasoning about forces in fluids.

## Equality of Pressure

On earth, fluids are also subject to the force of gravity, which acts vertically downward, and has a magnitude  $\gamma = \rho g$  per unit volume, where  $g$  is the acceleration of gravity, approximately 981 cm/s<sup>2</sup> or 32.15 ft/s<sup>2</sup>,  $\rho$  is the density, the mass per unit volume, expressed in g/cm<sup>3</sup>, kg/m<sup>3</sup>, or slug/ft<sup>3</sup>, and  $\gamma$  is the specific weight, measured in lb/in<sup>3</sup>, or lb/ft<sup>3</sup> (pcf).

## Atmospheric Pressure and its Effects

Suppose a vertical pipe is stood in a pool of water, and a vacuum pump applied to the upper end. Before we start the pump, the water levels outside and inside the pipe are equal, and the pressures on the surfaces are also equal and are equal to the atmospheric pressure.

Now start the pump. When it has sucked all the air out above the water, the pressure on the surface of the water inside the pipe is zero, and the pressure at the level of the water on the outside of the pipe is still the atmospheric pressure. There is the vapor pressure of the water to worry about if you want to be precise, but we neglect this complication in making our point.

A column of water 33.9 ft. high inside the pipe, with a vacuum above it, to balance the atmospheric pressure is required. If you were to do the same thing with liquid mercury, whose density at 0 °C is 13.5951 times that of water. The height of the column is 2.494 ft., 29.92 in, or 760.0 mm.

## Standard Atmospheric Pressure

This definition of the standard atmospheric pressure was established by Regnault back in the mid-19th century. In Great Britain, 30 in. Hg (inches of mercury) had been used previously. As a real-world matter, it is convenient to measure pressure differences by measuring the height of liquid columns, a practice known as manometry.

The barometer is a familiar example of this, and atmospheric pressures are traditionally given in terms of the length of a mercury column. To make a barometer, the barometric tube, closed at one end, is filled with mercury and then inverted and placed in a mercury reservoir.

Corrections must be made for temperature, because the density of mercury depends on the temperature, and the brass scale expands for capillarity if the tube is less than about 1 cm in diameter, and even slightly for altitude, since the value of  $g$  changes with altitude.

The vapor pressure of mercury is only 0.001201 mmHg at 20°C, so a correction from this source is negligible. For the usual case of a mercury column ( $\alpha = 0.000181792$  per °C) and a brass scale ( $\alpha = 0.0000184$  per °C) the temperature correction is -2.74 mm at 760 mm and 20°C.

Before reading the barometer scale, the mercury reservoir is raised or lowered until the surface of the mercury just touches a reference point, which is mirrored in the surface so it is easy to determine the proper position.

An aneroid barometer uses a partially evacuated chamber of thin metal that expands and contracts according to the external pressure. This movement is communicated to a needle that revolves in a dial. The materials and construction are arranged to give a low temperature coefficient. The instrument must be calibrated before use, and is usually arranged to read directly in elevations.

An aneroid barometer is much easier to use in field observations, such as in reconnaissance surveys. In a particular case, it would be read at the start of the day at the base camp, at various points in the vicinity, and then finally at the starting point, to determine the change in pressure with time.

The height differences can be calculated from  $h = 60,360 \log (P/p) [1 + (T + t - 64)/986]$  feet, where  $P$  and  $p$  are in the same units, and  $T$ ,  $t$  are in °F.

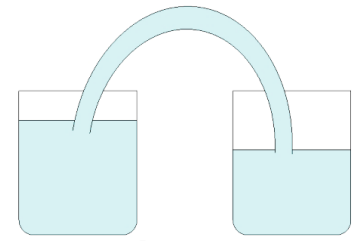

**Siphon**

An absolute pressure is referring to a vacuum, while a gauge pressure is referring to the atmospheric pressure at the moment.

A negative gauge pressure is a partial vacuum. When a vacuum is stated to be so many inches, this means the pressure below the atmospheric pressure of about 30 in.

A vacuum of 25 inches is the same thing as an absolute pressure of 5 inches (of mercury).

## **Vacuum**

The term *vacuum* indicates that the absolute pressure is less than the atmospheric pressure and that the gauge pressure is negative.

A complete or total vacuum would mean a pressure of 0 psia or -14.7 psig.

Since it is impossible to produce a total vacuum, the term vacuum, as used in this document, will mean all degrees of partial vacuum.

In a partial vacuum, the pressure would range from slightly less than 14.7 psia (0 psig) to slightly greater than 0 psia (-14.7 psig).

Again, backsiphonage results from atmospheric pressure exerted on a liquid, forcing it toward a supply system that is under a vacuum.

# Pumps and Pumping Water

Moving fluids plays a major role in the process of a plant. Liquid can only move on its own power from top to bottom or from a high pressure to a lower pressure system. This means that energy to the liquid must be added to move the liquid from a low to a higher level. To add the required energy to liquids, pumps are used. There are many different definitions of a pump but it can be described as: A machine used for the purpose of transferring quantities of liquids, gases and even solids from one location to another.

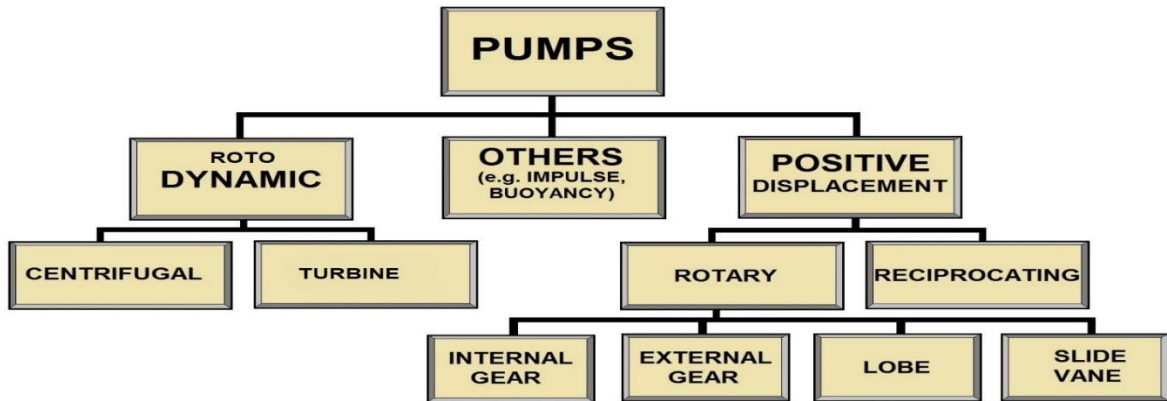

## PUMP CATEGORIES

### Types of Pumps

Pump types generally fall into two main categories - Rotodynamic and Positive Displacement, of which there are many forms.

The Rotodynamic pump transfers rotating mechanical energy into kinetic energy in the form of fluid velocity and pressure. The Centrifugal and Liquid Ring pumps are types of rotodynamic pump, which utilize centrifugal force to transfer the fluid being pumped.

The Rotary Lobe pump is a type of positive displacement pump, which directly displaces the pumped fluid from pump inlet to outlet in discrete volumes.

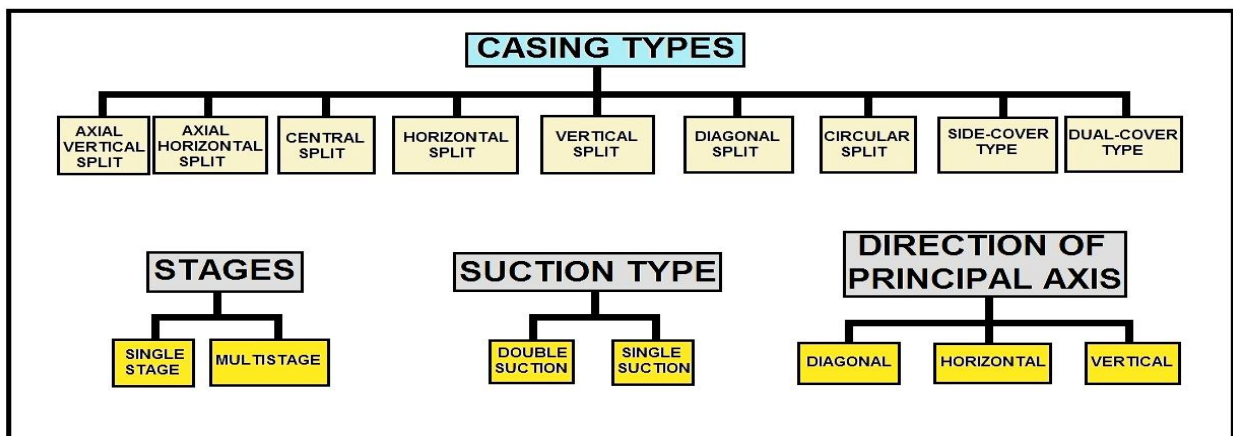

## PUMP CONFIGURATIONS

## General Pumping Fundamentals

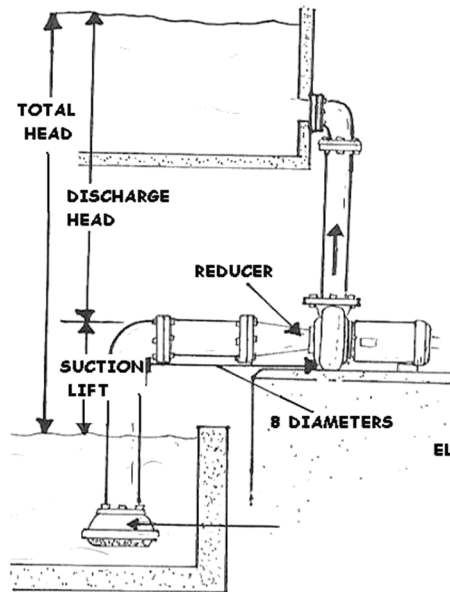

ILLUSTRATION 1

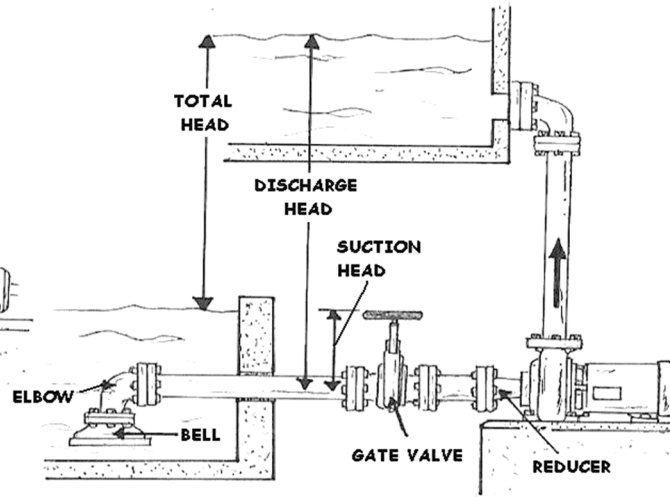

ILLUSTRATION 2

Here are the important points to consider about suction piping when the liquid being pumped is below the level of the pump:

- First, suction lift is when the level of water to be pumped is below the centerline of the pump. Sometimes suction lift is also referred to as '**negative suction head**'.
- The ability of the pump to lift water is the result of a partial vacuum created at the center of the pump.
- This works similar to sucking soda from a straw. As you gently suck on a straw, you are creating a vacuum or a pressure differential. Less pressure is exerted on the liquid inside the straw, so that the greater pressure is exerted by the atmosphere on the liquid around the outside of the straw, causing the liquid in the straw to move up. By sucking on the straw, this allows atmospheric pressure to move the liquid.
- Look at the diagram illustrated as "1". The foot valve is located at the end of the suction pipe of a pump. It opens to allow water to enter the suction side, but closes to prevent water from passing back out of the bottom end.
- The suction side of pipe should be one diameter larger than the pump inlet. The required eccentric reducer should be turned so that the top is flat and the bottom tapered.

Notice in illustration "2" that the liquid is above the level of the pump. Sometimes this is referred to as '**flooded suction**' or '**suction head**' situations.

## Complicated Pumps - Introduction

More complicated pumps have valves allowing them to work repetitively. These are usually check valves that open to allow passage in one direction, and close automatically to prevent reverse flow. There are many kinds of valves, and they are usually the most trouble-prone and complicated part of a pump. The force pump has two check valves in the cylinder, one for supply and the other for delivery. The supply valve opens when the cylinder volume increases, the delivery valve when the cylinder volume decreases.

The lift pump has a supply valve and a valve in the piston that allows the liquid to pass around it when the volume of the cylinder is reduced. The delivery in this case is from the upper part of the cylinder, which the piston does not enter.

Diaphragm pumps are force pumps in which the oscillating diaphragm takes the place of the piston. The diaphragm may be moved mechanically, or by the pressure of the fluid on one side of the diaphragm.

Some positive displacement pumps are shown below. The force and lift pumps are typically used for water. The force pump has two valves in the cylinder, while the lift pump has one valve in the cylinder and one in the piston. The maximum lift, or "suction," is determined by the atmospheric pressure, and either cylinder must be within this height of the free surface.

The force pump, however, can give an arbitrarily large pressure to the discharged fluid, as in the case of a diesel engine injector. A nozzle can be used to convert the pressure to velocity, to produce a jet, as for firefighting. Fire fighting force pumps usually have two cylinders feeding one receiver alternately. The air space in the receiver helps to make the water pressure uniform.

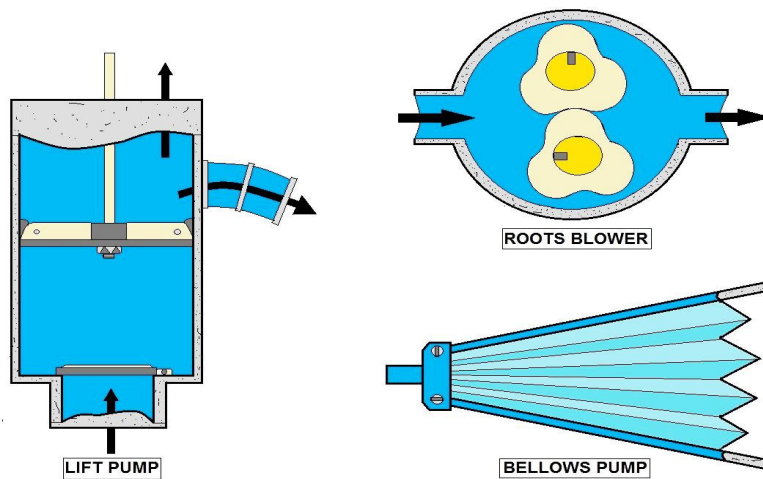

### POSITIVE DISPLACEMENT PUMP TYPES

The three pumps above are typically used for air, but would be equally applicable to liquids. The Roots blower has no valves, their place taken by the sliding contact between the rotors and the housing.

The Roots blower (Rotary Lobe) can either exhaust a receiver or provide air under moderate pressure, in large volumes.

The Bellows is a very old device, requiring no accurate machining. The single valve is in one or both sides of the expandable chamber. Another valve can be placed at the nozzle if required. The valve can be a piece of soft leather held close to holes in the chamber.

The Bicycle pump uses the valve on the valve stem of the tire or inner tube to hold pressure in the tire. The piston, which is attached to the discharge tube, has a flexible seal that seals when the cylinder is moved to compress the air, but allows air to pass when the movement is reversed.

Diaphragm and vane pumps are not shown, but they act the same way by varying the volume of a chamber, and directing the flow with check valves.

### **Fluid Properties**

The properties of the fluids being pumped can significantly affect the choice of pump.

#### **Key considerations include:**

- **Acidity/alkalinity (pH) and chemical composition.** Corrosive and acidic fluids can degrade pumps, and should be considered when selecting pump materials.
- **Operating temperature.** Pump materials and expansion, mechanical seal components, and packing materials need to be considered with pumped fluids that are hotter than 200°F.
- **Solids concentrations/particle sizes.** When pumping abrasive liquids such as industrial slurries, selecting a pump that will not clog or fail prematurely depends on particle size, hardness, and the volumetric percentage of solids.
- **Specific gravity.** The fluid specific gravity is the ratio of the fluid density to that of water under specified conditions. Specific gravity affects the energy required to lift and move the fluid, and must be considered when determining pump power requirements.
- **Vapor pressure.** A fluid's vapor pressure is the force per unit area that a fluid exerts in an effort to change phase from a liquid to a vapor, and depends on the fluid's chemical and physical properties. Proper consideration of the fluid's vapor pressure will help to minimize the risk of cavitation.
- **Viscosity.** The viscosity of a fluid is a measure of its resistance to motion. Since kinematic viscosity normally varies directly with temperature, the pumping system designer must know the viscosity of the fluid at the lowest anticipated pumping temperature. High viscosity fluids result in reduced centrifugal pump performance and increased power requirements. It is particularly important to consider pump suction-side line losses when pumping viscous fluids.

### **Environmental Considerations**

Important environmental considerations include ambient temperature and humidity, elevation above sea level, and whether the pump is to be installed indoors or outdoors.

### **Software Tools**

Most pump manufacturers have developed software or Web-based tools to assist in the pump selection process. Pump purchasers enter their fluid properties and system requirements to obtain a listing of suitable pumps. Software tools that allow you to evaluate and compare operating costs are available from private vendors.



## Progressing Cavity Pump Sub-Section

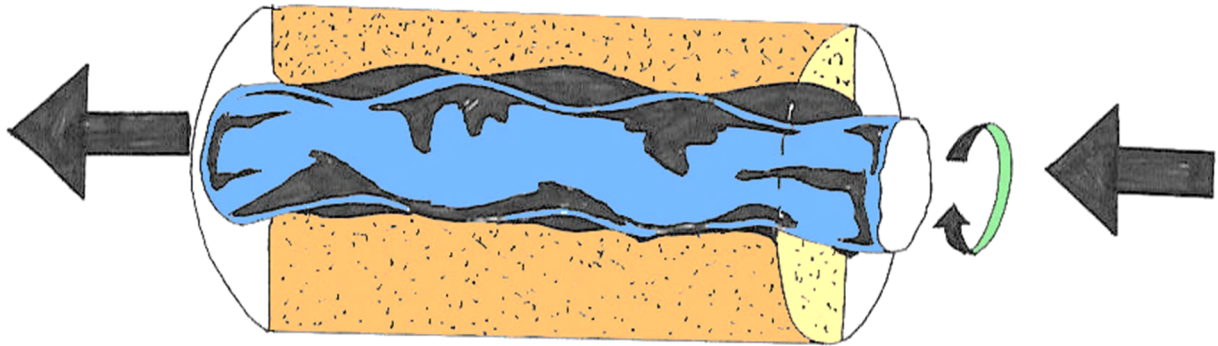

### PROGRESSING CAVITY ACTION

In this type of pump, components referred to as a rotor and an elastic stator provide the mechanical action used to force liquid from the suction side to the discharge side of the pump. As the rotor turns within the stator, cavities are formed which progress from the suction to the discharge end of the pump, conveying the pumped material.

The continuous seal between the rotor and the stator helices keeps the fluid moving steadily at a fixed flow rate proportional to the pump's rotational speed. Progressing cavity pumps are used to pump material very high in solids content. The progressive cavity pump must never be run dry, because the friction between the rotor and stator will quickly damage the pump.

#### More on the Progressive Cavity Pump

A progressive cavity pump is also known as a progressing cavity pump, eccentric screw pump, or even just cavity pump, and as is common in engineering generally, these pumps can often be referred to by using a generalized trademark. Hence, names can vary from industry to industry and even regionally; examples include: Mono pump, Moyno pump, Mohno pump, and Nemo pump.

This type of pump transfers fluid by means of the progress, through the pump, of a sequence of small, fixed shape, discrete cavities, as its rotor is turned. This leads to the volumetric flow rate being proportional to the rotation rate (bi-directionally) and to low levels of shearing being applied to the pumped fluid.

Therefore, these pumps have application in fluid metering and pumping of viscous or shear sensitive materials. It should be noted that the cavities taper down toward their ends and overlap with their neighbors, so that, in general, no flow pulsing is caused by the arrival of cavities at the outlet, other than that caused by compression of the fluid or pump components.

The principle of this pumping technique is frequently misunderstood; often it is believed to occur due to a dynamic effect caused by drag, or friction against the moving teeth of the screw rotor.

Nevertheless, in reality it is due to sealed cavities, like a piston pump, and so has similar operational characteristics, such as being able to pump at extremely low rates, even to high pressure, revealing the effect to be purely positive displacement.

The mechanical layout that causes the cavities to, uniquely, be of fixed dimensions as they move through the pump, is hard to visualize (it's essentially 3D nature renders diagrams quite ineffective for explanation), but it is accomplished by the preservation in shape of the gap formed between a helical shaft and a two start, twice the wavelength and double the diameter, helical hole, as the shaft is "rolled" around the inside surface of the hole. The motion of the rotor being the same as the smaller gears of a planetary gears system. This form of motion gives rise to the curves called Hypocycloids.

In order to produce a seal between cavities, the rotor requires a circular cross-section and the stator an oval one. The rotor so takes a form similar to a corkscrew, and this, combined with the off-center rotary motion, leads to the name; *Eccentric screw pump*.

Different rotor shapes and rotor/stator pitch ratios exist, but are specialized in that they don't generally allow complete sealing, so reducing low speed pressure and flow rate linearity, but improving actual flow rates, for a given pump size, and/or the pump's solids handling ability.

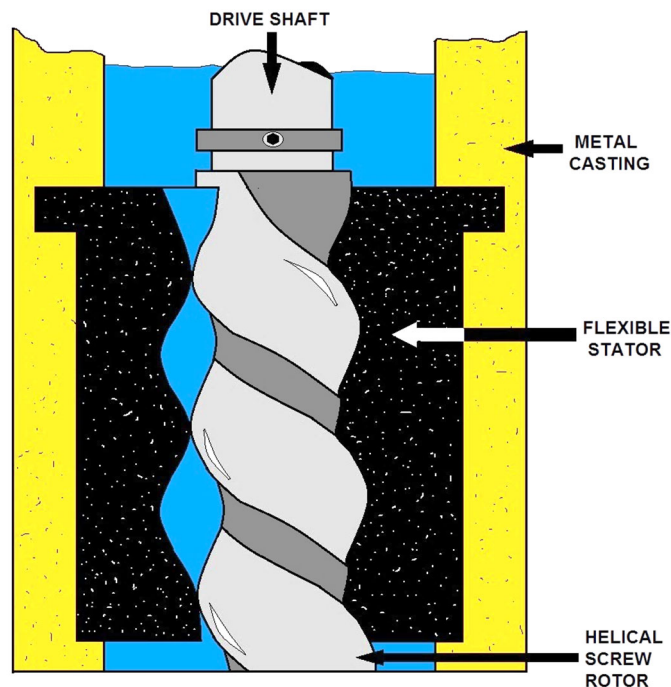

### PROGRESSIVE CAVITY PUMP

At a high enough pressure the sliding seals between cavities will leak some fluid rather than pumping it, so when pumping against high pressures a longer pump with more cavities is more effective, since each seal has only to deal with the pressure difference between adjacent cavities. Pumps with between two and a dozen or so cavities exist.

In operation, progressive cavity pumps are fundamentally fixed flow rate pumps, like piston pumps and peristaltic pumps. This type of pump needs a fundamentally different understanding to the types of pumps to which people are more commonly first introduced, namely ones that can be thought of as generating a pressure.

This can lead to the mistaken assumption that all pumps can have their flow rates adjusted by using a valve attached to their outlet, but with this type of pump this assumption is a problem, since such a valve will have practically no effect on the flow rate and completely closing it will involve very high, probably damaging, pressures being generated.

In order to prevent this, pumps are often fitted with cut-off pressure switches, burst disks (deliberately weak and easily replaced points), or a bypass pipe that allows a variable amount of a fluid to return to the inlet. With a bypass fitted, a fixed flow rate pump is effectively converted to a fixed pressure one.

At the points where the rotor touches the stator, the surfaces are generally traveling transversely, so small areas of sliding contact occur, these areas need to be lubricated by the fluid being pumped (Hydrodynamic lubrication), this can mean that more torque is required for starting, and if allowed to operate without fluid, called 'run dry', rapid deterioration of the stator can result.

While progressive cavity pumps offer long life and reliable service transporting thick or lumpy fluids, abrasive fluids will significantly shorten the life of the stator. However, slurries (particulates in a medium) can be pumped reliably, as long as the medium is viscous enough to maintain a lubrication layer around the particles and so provide protection to the stator.

Specific designs involve the rotor of the pump being made of a steel, coated in a smooth hard surface, normally chromium, with the body (the stator) made of a molded elastomer inside a metal tube body. The Elastomer core of the stator forms the required complex cavities.

The rotor is held against the inside surface of the stator by angled link arms, bearings (which have to be within the fluid) allowing it to roll around the inner surface (un-driven).

Elastomer is used for the stator to simplify the creation of the complex internal shape, created by means of casting, and also improves the quality and longevity of the seals by progressively swelling due to absorption of water and/or other common constituents of pumped fluids. Elastomer/pumped fluid compatibility will thus need to be taken into account.

Two common designs of stator are the "Equal-walled" and the "Unequal walled". The latter, having greater elastomer wall thickness at the peaks, allows larger-sized solids to pass through because of its increased ability to distort under pressure.

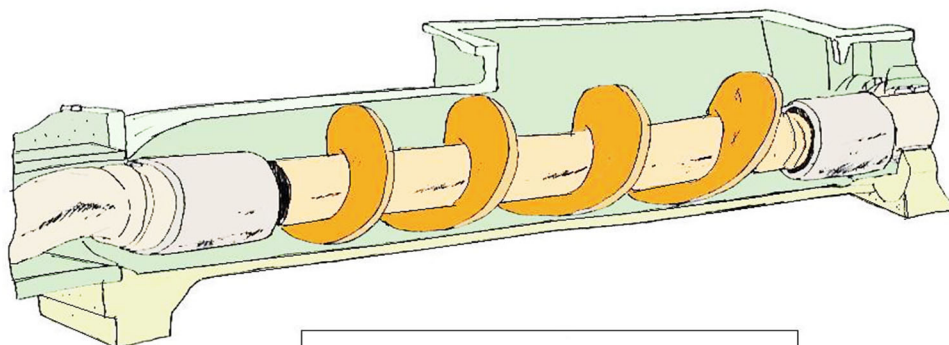

**PROGRESSIVE CAVITY PUMP**

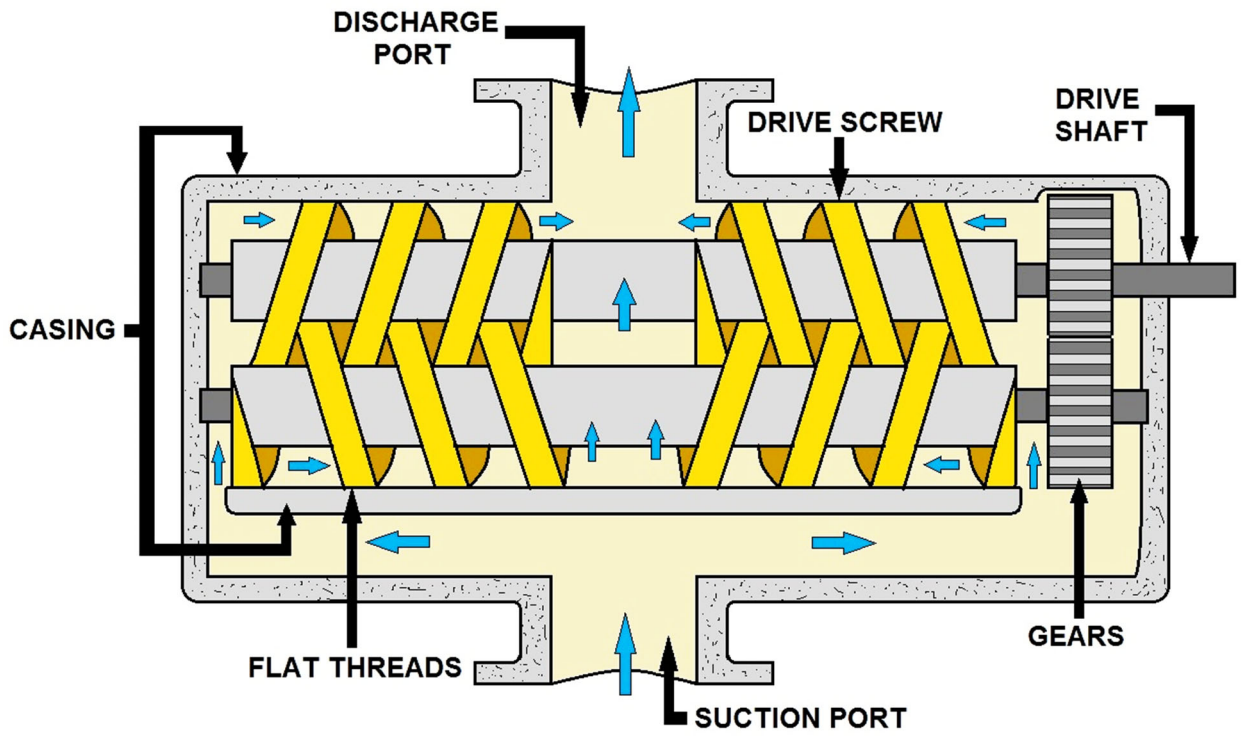

**POSITIVE DISPLACEMENT PUMP  
SCREW TYPE**

## Peristaltic Pump Sub-Section

A peristaltic pump is a type of positive displacement pump used for pumping a variety of fluids. The fluid is contained within a flexible tube fitted inside a circular pump casing (though linear peristaltic pumps have been made). A rotor with a number of "rollers", "shoes" or "wipers" attached to the external circumference compresses the flexible tube.

As the rotor turns, the part of the tube under compression closes (or "occludes") thus forcing the fluid to be pumped to move through the tube. Additionally, as the tube opens to its natural state after the passing of the cam ("restitution") fluid flow is induced to the pump. This process is called peristalsis and is used in many biological systems such as the gastrointestinal tract.



### Priming a Pump

Liquid and slurry pumps can lose prime and this will require the pump to be primed by adding liquid to the pump and inlet pipes to get the pump started. Loss of "prime" is usually due to ingestion of air into the pump. The clearances and displacement ratios in pumps used for liquids and other more viscous fluids cannot displace the air due to its lower density.

### Plunger Pumps

Plunger pumps are reciprocating positive displacement pumps. They consist of a cylinder with a reciprocating plunger in them. The suction and discharge valves are mounted in the head of the cylinder. In the suction stroke the plunger retracts and the suction valves open causing suction of fluid into the cylinder. In the forward stroke the plunger pushes the liquid out of the discharge valve.

### **Efficiency and Common Problems**

With only one cylinder in plunger pumps, the fluid flow varies between maximum flow when the plunger moves through the middle positions and zero flow when the plunger is at the end positions. A lot of energy is wasted when the fluid is accelerated in the piping system. Vibration and "water hammer" may be a serious problem. In general, the problems are compensated for by using two or more cylinders not working in phase with each other.

### **Priming a Pump**

Liquid and slurry pumps can lose prime and this will require the pump to be primed by adding liquid to the pump and inlet pipes to get the pump started.

Loss of "prime" is usually due to ingestion of air into the pump. The clearances and displacement ratios in pumps used for liquids and other more viscous fluids cannot displace the air due to its lower density.

### **Compressed-Air-Powered Double-Diaphragm Pumps**

One modern application of positive displacement diaphragm pumps is compressed-air-powered double-diaphragm pumps.

Run on compressed air these pumps are intrinsically safe by design, although all manufacturers offer ATEX certified models to comply with industry regulation.

Commonly seen in all areas of industry from shipping to processing, Wilden Pumps, Graco, SandPiper or ARO are generally the larger of the brands.

They are relatively inexpensive and can be used for almost any duty from pumping water out of bunds, to pumping hydrochloric acid from secure storage (dependent on how the pump is manufactured – elastomers / body construction).

Lift is normally limited to roughly 18 feet (6m) although heads can reach almost 200 Psi.



## Collection Systems, Lift Stations O&M Sub-Section

Wastewater lift stations are facilities designed to move wastewater from lower to higher elevation through pipes. Key elements of lift stations include a wastewater receiving well (wet-well), often equipped with a screen or grinding to remove coarse materials; pumps and piping with associated valves; motors; a power supply system; an equipment control and alarm system; and an odor control system and ventilation system.

Lift station equipment and systems are often installed in an enclosed structure. They can be constructed on-site (custom-designed) or prefabricated. Lift station capacities range from 20 gallons per minute to more than 100,000 gallons per minute. Pre-fabricated lift stations generally have capacities of up to 10,000 gallons per minute.

Centrifugal pumps are commonly used in lift stations. A trapped air column, or bubbler system, that senses pressure and level is commonly used for pump station control. Other control alternatives include electrodes placed at cut-off levels, floats, mechanical clutches, and floating mercury switches. A more sophisticated control operation involves the use of variable speed drives. Lift stations are typically provided with equipment for easy pump removal. Floor access hatches or openings above the pump room and an overhead monorail beam, bridge crane, or portable hoist are commonly used.

The two most common types of lift stations are the dry-pit or dry-well and submersible lift stations. In dry-well lift stations, pumps and valves are housed in a pump room (dry pit or dry-well), that is easily accessible. The wet-well is a separate chamber attached or located adjacent to the dry-well (pump room) structure.

Submersible lift stations do not have a separate pump room; the lift station header piping, associated valves, and flow meters are located in a separate dry vault at grade for easy access. Submersible lift stations include sealed pumps that operate submerged in the wet-well. These are removed to the surface periodically and reinstalled using guide rails and a hoist. A key advantage of dry-well lift stations is that they allow easy access for routine visual inspection and maintenance.

In general, they are easier to repair than submersible pumps. An advantage of submersible lift stations is that they typically cost less than dry-well stations and operate without frequent pump maintenance. Submersible lift stations do not usually include large aboveground structures and tend to blend in with their surrounding environment in residential areas. They require less space and are easier and less expensive to construct for wastewater flow capacities of 10,000 gallons per minute or less.

### Applicability

Lift stations are used to move wastewater from lower to higher elevation, particularly where the elevation of the source is not sufficient for gravity flow and/or when the use of gravity conveyance will result in excessive excavation depths and high sewer construction costs.

### Current Status

Lift stations are widely used in wastewater conveyance systems. Dry-well lift stations have been used in the industry for many years. However, the current industry-wide trend is to replace drywell lift stations of small and medium size (typically less than 6,350 gallons per minute with

submersible lift stations mainly because of lower costs, a smaller footprint, and simplified operation and maintenance.

Variable speed pumping is often used to optimize pump performance and minimize power use. Several types of variable-speed pumping equipment are available, including variable voltage and frequency drives, eddy current couplings, and mechanical variable-speed drives.

Variable-speed pumping can reduce the size and cost of the wetwell and allows the pumps to operate at maximum efficiency under a variety of flow conditions. Because variable-speed pumping allows lift station discharge to match inflow, only nominal wet-well storage volume is required and the well water level is maintained at a near constant elevation. Variable-speed pumping may allow a given flow range to be achieved with fewer pumps than a constant-speed alternative.

Variable-speed stations also minimize the number of pump starts and stops, reducing mechanical wear. Although there is significant energy saving potential for stations with large friction losses, it may not justify the additional capital costs unless the cost of power is relatively high. Variable speed equipment also requires more room within the lift station and may produce more noise and heat than constant speed pumps.

Lift stations are complex facilities with many auxiliary systems. Therefore, they are less reliable than gravity wastewater conveyance. However, lift station reliability can be significantly improved by providing stand-by equipment (pumps and controls) and emergency power supply systems. In addition, lift station reliability is improved by using non-clog pumps suitable for the particular wastewater quality and by applying emergency alarm and automatic control systems.

### **Advantages**

Lift stations are used to reduce the capital cost of sewer system construction. When gravity sewers are installed in trenches deeper than 10 feet, the cost of sewer line installation increases significantly because of the more complex and costly excavation equipment and trench shoring techniques required. The size of the gravity sewer lines is dependent on the minimum pipe slope and flow. Pumping wastewater can convey the same flow using smaller pipeline size at shallower depth, and thereby, reducing pipeline costs.

### **Disadvantages**

Compared to sewer lines where gravity drives wastewater flow, lift stations require a source of electric power. If the power supply is interrupted, flow conveyance is discontinued and can result in flooding upstream of the lift station, It can also interrupt the normal operation of the downstream wastewater conveyance and treatment facilities. This limitation is typically addressed by providing an emergency power supply.

Key disadvantages of lift stations include the high cost to construct and maintain and the potential for odors and noise. Lift stations also require a significant amount of power, are sometimes expensive to upgrade, and may create public concerns and negative public reaction. The low cost of gravity wastewater conveyance and the higher costs of building, operating, and maintaining lift stations means that wastewater pumping should be avoided, if possible and technically feasible.



Wastewater pumping can be eliminated or reduced by selecting alternative sewer routes or extending a gravity sewer using direction drilling or other state-of-the-art deep excavation methods. If such alternatives are viable, a cost benefit analysis can determine if a lift station is the most viable choice.

### **Design Criteria**

Cost effective lift stations are designed to: (1) match pump capacity, type, and configuration with wastewater quantity and quality; (2) provide reliable and uninterrupted operation; (3) allow for easy operation and maintenance of the installed equipment; (4) accommodate future capacity expansion; (5) avoid septic conditions and excessive release of odors in the collection system and at the lift station; (6) minimize environmental and landscape impacts on the surrounding residential and commercial developments; and (7) avoid flooding of the lift station and the surrounding areas.

### **Wet-well**

Wet-well design depends on the type of lift station configuration (submersible or dry-well) and the type of pump controls (constant or variable speed). Wet-wells are typically designed large enough to prevent rapid pump cycling but small enough to prevent a long detention time and associated odor release.

Wet-well maximum detention time in constant speed pumps is typically 20 to 30 minutes. Use of variable frequency drives for pump speed control allows wet-well detention time reduction to 5 to 15 minutes. The minimum recommended wet-well bottom slope is to 2:1 to allow self-cleaning and minimum deposit of debris. Effective volume of the wet-well may include sewer pipelines, especially when variable speed drives are used. Wet-wells should always hold some level of sewage to minimize odor release. Bar screens or grinders are often installed in or upstream of the wet-well to minimize pump clogging problems.

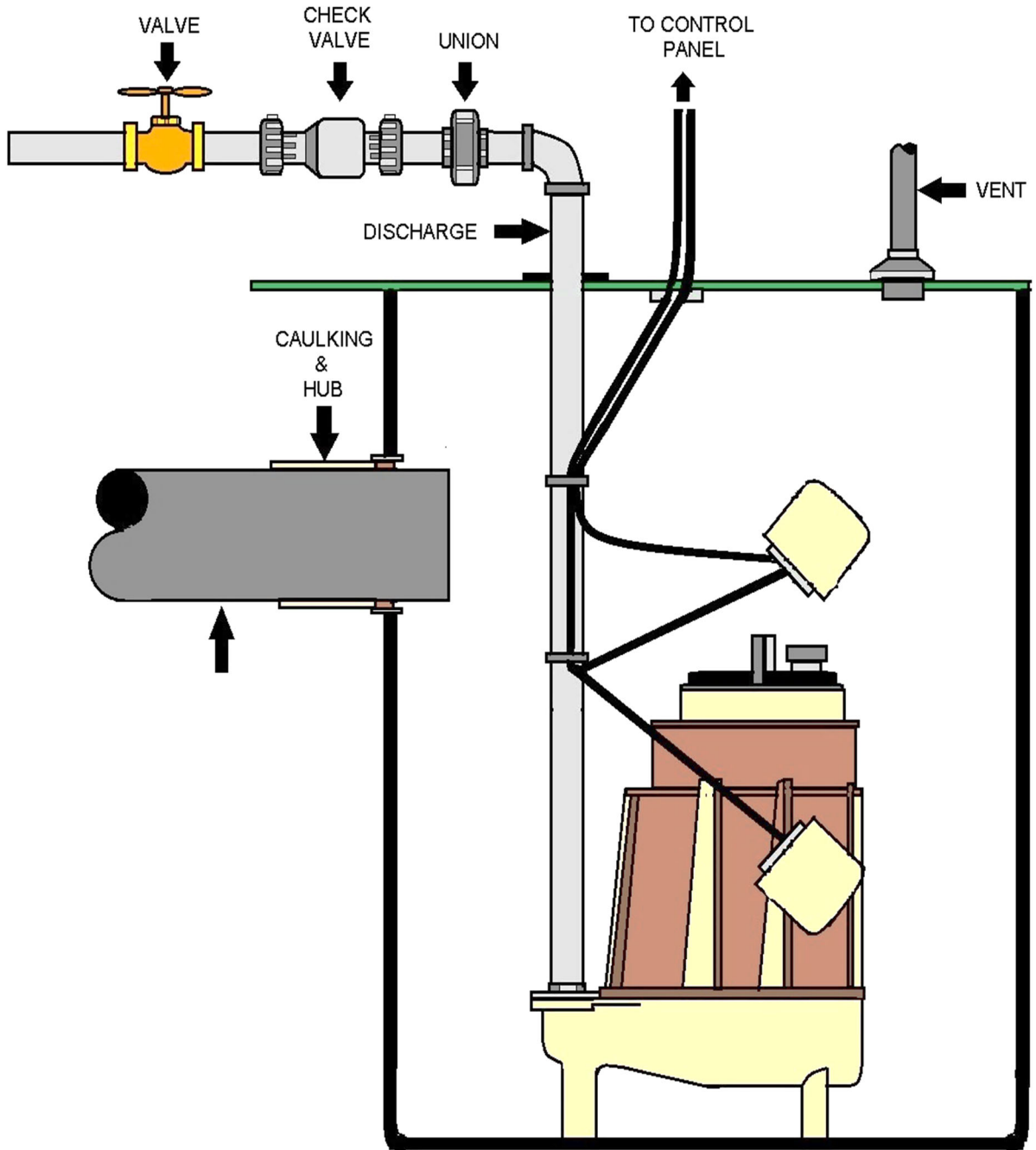

**SEWER EJECTOR SYSTEM DIAGRAM**

## **Wastewater Pump Sub-Section**

The number of wastewater pumps and associated capacity should be selected to provide head capacity characteristics that correspond as nearly as possible to wastewater quantity fluctuations. This can be accomplished by preparing pump/pipeline system head-capacity curves showing all conditions of head (elevation of a free surface of water) and capacity under which the pumps will be required to operate.

The number of pumps to be installed in a lift station depends on the station capacity, the range of flow and the regulations. In small stations, with maximum inflows of less than 700 gallons per minute), two pumps are customarily installed, with each unit able to meet the maximum influent rate. For larger lift stations, the size and number of pumps should be selected so that the range of influent flow rates can be met without starting and stopping pumps too frequently and without excessive wet-well storage.

Depending on the system, the pumps are designed to run at a reduced rate. The pumps may also alternate to equalize wear and tear. Additional pumps may provide intermediate capacities better matched to typical daily flows. An alternative option is to provide flow flexibility with variable speed pumps.

For pump stations with high head-losses, the single pump flow approach is usually the most suitable. Parallel pumping is not as effective for such stations because two pumps operating together yield only slightly higher flows than one pump. If the peak flow is to be achieved with multiple pumps in parallel, the lift station must be equipped with at least three pumps: two duty pumps that together provide peak flow and one standby pump for emergency backup.

Parallel peak pumping is typically used in large lift stations with relatively flat system head curves. Such curves allow multiple pumps to deliver substantially more flow than a single pump. The use of multiple pumps in parallel provides more flexibility.

Several types of centrifugal pumps are used in wastewater lift stations. In the straight-flow centrifugal pumps, wastewater does not change direction as it passes through the pumps and into the discharge pipe. These pumps are well suited for low-flow/high head conditions.

In angle-flow pumps, wastewater enters the impeller axially and passes through the volute casing at 90 degrees to its original direction. This type of pump is appropriate for pumping against low or moderate heads. Mixed flow pumps are most viable for pumping large quantities of wastewater at low head. In these pumps, the outside diameter of the impeller is less than an ordinary centrifugal pump, increasing flow volume.

### **Ventilation**

Ventilation and heating are required if the lift station includes an area routinely entered by personnel. Ventilation is particularly important to prevent the collection of toxic and/or explosive gases. According to the Nation Fire Protection Association (NFPA) Section 820, all continuous ventilation systems should be fitted with flow detection devices connected to alarm systems to indicate ventilation system failure. Dry-well ventilation codes typically require six continuous air changes per hour or 30 intermittent air changes per hour. Wet-wells typically require 12 continuous air changes per hour or 60 intermittent air changes per hour. Motor control center (MCC) rooms should have a ventilation system adequate to provide six air changes per hour and should be air conditioned to between 13 and 32 degrees Celsius (55 to 90 degrees F).

If the control room is combined with an MCC room, the temperature should not exceed 30 degrees C or 85 degrees F. All other spaces should be designed for 12 air changes per hour. The minimum temperature should be 13 degrees C (55 degrees F) whenever chemicals are stored or used.

### **Odor Control**

Odor control is frequently required for lift stations. A relatively simple and widely used odor control alternative is minimizing wet-well turbulence. More effective options include collection of odors generated at the lift station and treating them in scrubbers or biofilters or the addition of odor control chemicals to the sewer upstream of the lift station. Chemicals typically used for odor control include chlorine, hydrogen peroxide, metal salts (ferric chloride and ferrous sulfate) oxygen, air, and potassium permanganate. Chemicals should be closely monitored to avoid affecting downstream treatment processes, such as extended aeration.

### **Power Supply**

The reliability of power for the pump motor drives is a basic design consideration. Commonly used methods of emergency power supply include electric power feed from two independent power distribution lines; an on-site standby generator; an adequate portable generator with quick connection; a stand-by engine driven pump; ready access to a suitable portable pumping unit and appropriate connections; and availability of an adequate holding facility for wastewater storage upstream of the lift station.

### **Performance**

The overall performance of a lift station depends on the performance of the pumps. All pumps have four common performance characteristics: capacity, head, power, and overall efficiency. Capacity (flow rate) is the quantity of liquid pumped per unit of time, typically measured as gallons per minute (gpm) or million gallons per day (mgd).

Head is the energy supplied to the wastewater per unit weight, typically expressed as feet of water. Power is the energy consumed by a pump per unit time, typically measured as kilowatt-hours. Overall efficiency is the ratio of useful hydraulic work performed to actual work input. Efficiency reflects the pump relative power losses and is usually measured as a percentage of applied power.

## Lift Station Inspection Sub-Section

Lift station operation is usually automated and does not require continuous on-site operator presence. However, frequent inspections are recommended to ensure normal functioning and to identify potential problems. Lift station inspection typically includes observation of pumps, motors and drives for unusual noise, vibration, heating and leakage, check of pump suction and discharge lines for valving arrangement and leakage, check of control panel switches for proper position, monitoring of discharge pump rates and pump speed, and monitoring of the pump suction and discharge pressure.

Weekly inspections are typically conducted, although the frequency really depends on the size of the lift station. If a lift station is equipped with grinder bar screens to remove coarse materials from the wastewater, these materials are collected in containers and disposed of to a sanitary landfill site as needed. If the lift station has a scrubber system for odor control, chemicals are supplied and replenished typically every three months. If chemicals are added for odor control ahead of the lift station, the chemical feed stations should be inspected weekly and chemicals replenished as needed.

The most labor-intensive task for lift stations is routine preventive maintenance. A well-planned maintenance program for lift station pumps prevents unnecessary equipment wear and downtime. Lift station operators must maintain an inventory of critical spare parts. The number of spare parts in the inventory depends on the critical needs of the unit, the rate at which the part normally fails, and the availability of the part. The operator should tabulate each pumping element in the system and its recommended spare parts. This information is typically available from the operation and maintenance manuals provided with the lift station.

### Operating Costs

Lift station costs depend on many factors, including

- (1) wastewater quality, quantity, and projections;
- (2) zoning and land use planning of the area where the lift station will be located;
- (3) alternatives for standby power sources;
- (4) operation and maintenance needs and support;
- (5) soil properties and underground conditions;
- (6) required lift to the receiving (discharge) sewer line;
- (7) the severity of impact of accidental sewage spill upon the local area; and
- (8) the need for an odor control system.

These site and system specific factors must be examined and incorporated in preparing a lift station cost estimate.

### Construction Costs

The most important factors influencing cost are the design lift station capacity and the installed pump power. Another cost factor is the lift station complexity. Factors which classify a lift station as complex include two or more of the following:

- (1) extent of excavation;
- (2) congested site and/or restricted access;
- (3) rock excavation;
- (4) extensive dewatering requirements, such as cofferdams;
- (5) site conflicts, including modification or removal of existing facilities;
- (6) special foundations, including piling;

- (7) dual power supply and on-site switch stations and emergency power generator; and
- (8) high pumping heads (design heads in excess of 200 ft).

Mechanical, electrical, and control equipment delivered to a pumping station construction site typically account for 15 to 30 percent of total construction costs. Lift station construction has a significant economy-of-scale. Typically, if the capacity of a lift station is increased 100 percent, the construction cost would increase only 50 to 55 percent. An important consideration is that two identical lift stations will cost 25 to 30 percent more than a single station of the same combined capacity. Usually, complex lift stations cost two to three times more than more simple lift stations with no construction complications.

### **Operation and Maintenance Costs**

Lift station operation and maintenance costs include power, labor, maintenance, and chemicals (if used for odor control). Usually, the costs for solids disposal are minimal, but are included if the lift station is equipped with bar screens to remove coarse materials from the wastewater. Typically, power costs account for 85 to 95 percent of the total operation and maintenance costs and are directly proportional to the unit cost of power and the actual power used by the lift station pumps. Labor costs average 1 to 2 percent of total costs. Annual maintenance costs vary, depending on the complexity of the equipment and instrumentation.



Each worker must be trained to get out of the confined space as rapidly as possible without help whenever an order to evacuate is given by the attendant, whenever an automatic evacuation alarm is activated, or whenever workers recognize the warning signs of exposure to substances that could be found in the confined space. They must also be made aware of the toxic effects or symptoms of exposure to hazardous materials they could encounter in the confined space. This includes anything that could be absorbed through the skin or which could be carried through the skin by any solvents that are used. They must be trained to relay an alarm to the attendant and to attempt self-rescue immediately upon becoming aware of these effects.

## Pumping and Lift Station Chapter Highlights

### Pump Stations

Proper operation, maintenance, and repair of pump stations typically requires special electrical, hydraulic, and mechanical knowledge. Pump station failure may damage equipment, the environment, or endanger public health. Variation in equipment types, pump station configuration, and geographical factors determine pump station design and O&M requirements.

The reviewer should verify that the O&M manual contains procedures in writing for the following:

- Are pumps rotated manually or automatically? If manually, how frequently?
- Are wet well operating levels set to limit pump starts and stops?
- Is there a procedure for manipulating pump operations (manually or automatically) during wet weather to increase in-line storage of wet weather flows?
- Is flow monitoring provided? How is the collected data used?
- Does the pump station have capacity-related overflows? Maintenance related overflows? Is overflow monitoring provided?
- Is there a history of power outages? Is there a source of emergency power? If the emergency power source is a generator, is it regularly exercised under load?

### Operation and Maintenance (O&M) Activities

Proactive O&M initiatives are critical to effective prevention of SSOs. Nationwide, improved O&M activities such as implementation of hot spot cleaning programs, routine pipeline cleaning, and video inspections to find structural deficiencies have dramatically reduced the frequency and severity of SSOs in many cities.

Your system should conduct various types of proactive O&M activities throughout their service area.

Suggested goals of your system's wastewater collection system maintenance programs should be as follows:

- Maintain wastewater collection system flow capacity.
- Reduce the frequency and duration of overflow events.
- Optimize the use of resources.
- Optimize the life cycle of system components.
- Maintain accurate maintenance records.

Your section of the CMOM Plan shall include descriptions of maintenance facilities, mapping and data management, routine O&M activities, system repairs, and training.

## **Maintenance Program**

Every collection system owner or operator should have a well-planned, systematic, and comprehensive maintenance program. The goals of a maintenance program should include:

- Prevention of overflows.
- Maximization of service and system reliability at minimum cost.
- Assurance of infrastructure sustainability (i.e., ensure all components reach their service life).

There should then be procedures which describe the maintenance approach for various systems. In addition, there should be detailed instructions for the maintenance and repair of individual facilities. These instructions should provide a level of detail such that any qualified collection system personnel or repair technician could perform the repair or maintenance activity.

Maintenance may be planned or unplanned. There are essentially two types of planned maintenance; predictive and preventive. Predictive maintenance is a method that tries to look for early warning signs of equipment failure such that emergency maintenance is avoided.

Preventive maintenance consists of scheduled maintenance activities performed on a regular basis. There are two types of unplanned maintenance, corrective and emergency. Corrective maintenance consists of scheduled repairs to problems identified under planned or predictive maintenance. Emergency maintenance is activities (typically repairs) performed in response to a serious equipment or line failure where action must be taken immediately. The goal of every owner or operator should be to reduce corrective and emergency maintenance through the use of planned and predictive maintenance. The reviewer should evaluate the progress of the owner or operator in achieving that goal.

### **The goals of the reviewer in assessment of the maintenance program are:**

- Identify SSOs caused by inadequate maintenance.
- Determine maintenance trends (i.e., frequent emergency maintenance performed as opposed to predictive maintenance.)
- Identify sustainability issues (i.e., inadequate maintenance to allow system components to reach service life and/or many components nearing or at service life.)

## **Pump Station Inspection**

Pump stations should be subject to inspection and preventive maintenance on a regular schedule. The frequency of inspection may vary from once a week, for a reliable pump station equipped with a telemetry system, to continuous staffing at a large pump station.

The basic inspection should include verification that alarm systems are operating properly, wet well levels are properly set, all indicator lights and voltage readings are within acceptable limits, suction and discharge pressures are within normal limits, that the pumps are running without excessive heat or vibration and have the required amount of lubrication, and that the emergency generator is ready if needed. Less frequent inspections may include such items as vibration analysis and internal inspection of pump components.



## Pump Station Checklist

Observations and tasks performed should be recorded in a log book or on a checklist at the pump station. It is important to note how this data returns to the central maintenance data management system. At the time of the inspection, collection system personnel may perform minor repairs if necessary. If non-emergency repairs are required that are beyond the staff's training, it will probably be necessary to prepare a work order which routes a request through the proper channels to initiate the repair action. During the review the reviewer should check a random number of work orders to see how they move through the system. The reviewer should note whether repairs are being carried out promptly. In pump stations, for critical equipment (pumps, drives, power equipment, and control equipment), there should not be much backlog, unless the staff is waiting for parts.

During the review, the reviewer should also make on-site observations of representative pump stations. The reviewer should plan at least half an hour to look at the simplest two-pump prefabricated station, and one to two hours to look at a larger station. In large systems, drive time between stations may be significant. The reviewer should strive to see a range of pump station sizes and types (i.e., the largest, smallest, most remote, and any that review of work orders has indicated might be problematic).

Overall, the pump station should be clean, in good structural condition, and exhibit minimal odor. The reviewer should note the settings of the pumps (i.e., which are operating, which are on stand-by, and which are not operating and why). The operating pumps should be observed for noise, heat, and excessive vibration. The settings in the wet well should be noted (as indicated on the controls, as direct observation of the wet well by the reviewer is not recommended) and the presence of any flashing alarm lights.

### Atmospheric Hazards

The reviewer is reminded of the atmospheric hazards in a pump station (make sure ventilation has been running prior to arrival) and to avoid confined space entry. If the pump station has an overflow its outlet should be observed, if possible, for signs of any recent overflows such as floatable materials or toilet paper. The reviewer should check the log book and/or checklist kept at the pump station to ensure that records are current and all maintenance activities have been performed. Below is a listing of items that indicate inadequate maintenance:

- Overall poor housekeeping and cleanliness.
- Excessive grease accumulation in wet well.
- Excessive corrosion on railings, ladders, and other metal components.
  - Sagging, worn, improperly sized, or inadequate belts.
- Excessive equipment out of service for repair or any equipment for which repair has not been ordered (i.e., a work order issued.)
  - Pumps running with excessive heat, vibration, or noise.
- Peeling paint and/or dirty equipment (the care given to equipment's outer surfaces often, but not always, mirrors internal condition.)
- Check valves not closing when pumps shut off.
- Inoperative instrumentation, alarms, and recording equipment.
  - "Jury-rigged" repairs (i.e., "temporary" repairs using inappropriate materials.)
- Leakage from pumps, piping, or valves (some types of pump seals are designed to "leak" seal water.)
- Inadequate lighting or ineffective/inoperative ventilation equipment.

## **Routine Preventative O&M Activities – Wastewater Lift Stations and Force Mains**

### **Perform Regular Preventative Maintenance**

The wastewater collections service technicians should perform regular preventative maintenance on the various components at the lift stations. An outside contractor may also be used to clean each lift station twice a year.

Most wastewater lift station and force main operations are typically remotely monitored and controlled through a telemetry or WIFI system that sends signals to the system's operation center. In the event of a malfunction, all of the lift stations should have redundant pump and pump monitoring systems, and all should have emergency backup power generation.

### **System Repairs**

Deficiencies in the sewer system requiring repair are noted during cleaning and video inspections or are discovered through investigation of customer complaints. A Supervisor should arrange for all repairs; small repairs are often completed by the system's crews and larger repairs may be completed by a qualified outside contractor.

Deficiencies in lift stations and force mains requiring repair should be noted by the wastewater collections technicians during their routine visits, by alarms or through customer complaints. The Supervisor should make arrangements for all lift station and force main repairs.

### **Maintenance Budgeting**

The cost of a maintenance program is a significant part of the annual operating budget. The collection system owner or operator should track all maintenance costs incurred throughout the year, both by internal staff and contractors, to ensure that the budget is based on representative costs from past years. Budgets should be developed from past cost records which usually are categorized according to preventive maintenance, corrective maintenance, and projected and actual major repair requirements. Annual costs should be compared to the budget periodically to control maintenance expenditures.

The reviewer should evaluate the maintenance budget, keeping in mind the system's characteristics, such as age. Costs for emergency repairs should be a relatively small percentage of the budget--five to ten percent would not be considered excessive. The establishment of an "emergency reserve" may also be included as part of the maintenance budget. This is especially useful where full replacement is not funded. The budget should also be considered in light of maintenance work order backlog.

### **Planned and Unplanned Maintenance**

A planned maintenance program is a systematic approach to performing maintenance activities so that equipment failure is avoided. Planned maintenance is composed of predictive and preventive maintenance. In the end, a good planned maintenance program should reduce material, capital repair, and replacement costs, improve personnel utilization and morale, reduce SSOs, and sustain public confidence.

Examples of predictive maintenance includes monitoring equipment for early warning signs of impending failure, such as excess vibration, heat, dirty oil, and leakage. Assessment and inspection activities can be classified as predictive maintenance. Vibration and lubrication analyses, thermography, and ultrasonics are among the more common predictive maintenance tools.

Predictive maintenance also takes into account historical information about the system as all systems will deteriorate over time.

A predictive maintenance program strives to identify potential problem areas and uncover trends that could affect equipment performance. Predictive maintenance offers an early warning. It allows collection system personnel to detect early signs of increasing rates of wear and therefore failure, and thus shift a “corrective” task into a “planned” task. To be truly effectively predictive, however, maintenance should not spur personnel into doing the work too soon and wasting useful life and value of the equipment in question.

The reviewer should inquire as to whether tools such as vibration and lubrication analysis, thermography, or ultrasonics are used, and obtain information on the extent of the programs.

The basis of a good predictive maintenance program is recordkeeping. Only with accurate recordkeeping can baseline conditions be established, problem areas identified, and a proactive approach taken to repairs and replacement.

Effective preventive maintenance minimizes system costs and environmental impacts by reducing breakdowns and thus the need for corrective or emergency maintenance; improves reliability by minimizing the time equipment is out of service; increases the useful life of equipment, thus avoiding costly premature replacement; and avoids potential noncompliance situations.

#### **An Effective Preventive Maintenance Program Includes:**

- Trained personnel.
- Scheduling based on system specific knowledge.
- Detailed instructions related to the maintenance of various pieces of equipment.
- A system for recordkeeping.

System knowledge in the form of maps, historical knowledge and records. An effective preventive maintenance program builds on the inspection activities and predictive maintenance described above, and includes a well thought-out schedule for these activities.

The basis of the schedule for mechanical equipment maintenance (i.e., pump station components) should be the manufacturers’ recommended activities and frequencies. This schedule may then be augmented by the knowledge and experience of collection system personnel to reflect the site-specific requirements.

The schedule for sewer line cleaning, inspection, root removal, and repair activities should be based on periodic inspection data. In most systems, uniform frequencies for sewer line cleaning, inspection, and root removal are not necessary and inefficient. In many systems, a relatively small percentage of the pipe generates most of the problems.

Efficient use of inspection data allows the owner or operator to implement a schedule in the most constructive manner. In rare cases it may be appropriate to reduce maintenance frequency for a particular piece of equipment.

#### **Lubrication**

Lubrication is probably one of the most important maintenance activities for mechanical systems, such as pumps and motors. Frequencies of lubrication, choice of lubricant and lubrication procedure are all important factors in this activity. These items should closely follow manufacturer instructions, but may be modified to fit site-specific conditions and particular equipment applications. An example of a scheduling code and maintenance schedule for a pump is shown below:

## Guide for Evaluating CMOM Programs at Sanitary Sewer Collection Systems

<b>Rotary Pump Maintenance Schedule</b>	
Frequency	Maintenance Required
D	Check packing gland assembly
D	Check discharge pressure
S	Inspect and lubricate bearings
A	Flush bearings and replace lubricant

D = Daily A = Annually S = Semiannually

Typically, there is a maintenance card or record for each piece of equipment within the collection system. These records should contain maintenance recommendations, schedule, and instructions on conducting the specific maintenance activity. The records should include documentation regarding any maintenance activities conducted to date and other observations related to that piece of equipment or system.

Maintenance records are generally kept where maintenance personnel have easy access to them. The reviewer should examine the full series of periodic work orders (i.e. weekly, monthly, semiannually, and annually) for a selection of system components (e.g., a few pump stations, several line segments).

The reviewer should then compare the recommended maintenance frequency to that which is actually performed. He or she should also look at the backlog of work; not focusing solely on the number of backlogged work orders, but on what that number represents in time. A very large system can have a hundred orders backlogged and only be one week behind. In a computerized system, a listing of all open work orders is usually very simple for collection system personnel to generate. The owner or operator should be able to explain their system for prioritizing work orders.

The reviewer needs to clearly understand the following:

- How the maintenance data management system works
- How work orders are generated and distributed
- How field crews use the work orders
- How data from the field is collected and returned
- How and on whose authority work orders are closed out

The reviewer should check to see if data entry is timely and up to date.

### **Unplanned Maintenance**

Unplanned maintenance is that which takes place in response to equipment breakdowns or emergencies. Unplanned maintenance may be corrective or emergency maintenance. Corrective maintenance could occur as a result of preventive or predictive maintenance activities which identified a problem situation.

A work order should be issued so that the request for corrective maintenance is directed to the proper personnel. An example of non-emergency corrective maintenance could be a broken belt on a belt driven pump.

The worn belt was not detected and replaced through preventive maintenance and therefore the pump is out of service until corrective maintenance can be performed. Although the pump station may function with one pump out of service, should another pump fail, the situation may become critical during peak flow periods.

If the information can be easily generated the reviewer should select a sampling of work orders and compare them to the corrective maintenance database to determine if repairs are being made in a timely manner. Reviewers should note the current backlog of corrective maintenance work orders. A corrective maintenance backlog of two weeks or less would indicate an owner or operator in control of corrective maintenance. The owner or operator should be able to explain corrective maintenance work orders that have not been completed within six months.

### **Corrective Maintenance**

Corrective maintenance takes resources away from predictive and preventive maintenance. When corrective maintenance becomes a predominant activity, personnel may not be able to perform planned maintenance, thus leading to more corrective maintenance and emergency situations. Emergency maintenance occurs when a piece of equipment or system fails, creating a threat to public health, the environment, or associated equipment. This type of maintenance involves repairs on short notice, of malfunctioning equipment or sewers. A broken force main, totally non-functional pump station and street cave-ins are all examples of emergency situations.

### **Types of Portable Emergency Equipment**

- Bypass pumps
- Portable generator
- Air compressor, trailer-mounted
- Manhole lifters and gas testing equipment
- Sewer rodder and/or flushing machine
- Portable lights and hand tools
- Chemical spray units (for insects and rodent control)
- Truck (1-ton) and trailers
- Vacuum truck
- Repair equipment for excavation (backhoe, shoring equipment, concrete mixers, gasoline operated saws, traffic control equipment, etc.)
- Confined space entry gear

### **Emergency Crews**

Emergency crews should be geared to a 24-hour-a-day, year-round operation. Most large systems have staffed 24-hour crews; many small systems have an “on-call” system. The owner or operator should be able to produce written procedures which spell out the type of action to take in a particular type of emergency and the equipment and personnel requirements necessary to carry out the action. The crews should have copies of these procedures and be familiar with them. Equipment must be located in an easily accessible area and be ready to move in a short period of time.

Vehicles and equipment must be ready to perform, under extreme climatic conditions if necessary. The emergency crew may need materials such as piping, pipe fittings, bedding materials, and concrete. The owner or operator should have supplies on hand to allow for two point (i.e. segment, fitting, or appurtenance) repairs of any part of its system. The reviewer should note the presence of supplies during the review of the yard where equipment and spare parts are maintained and personnel are dispatched.

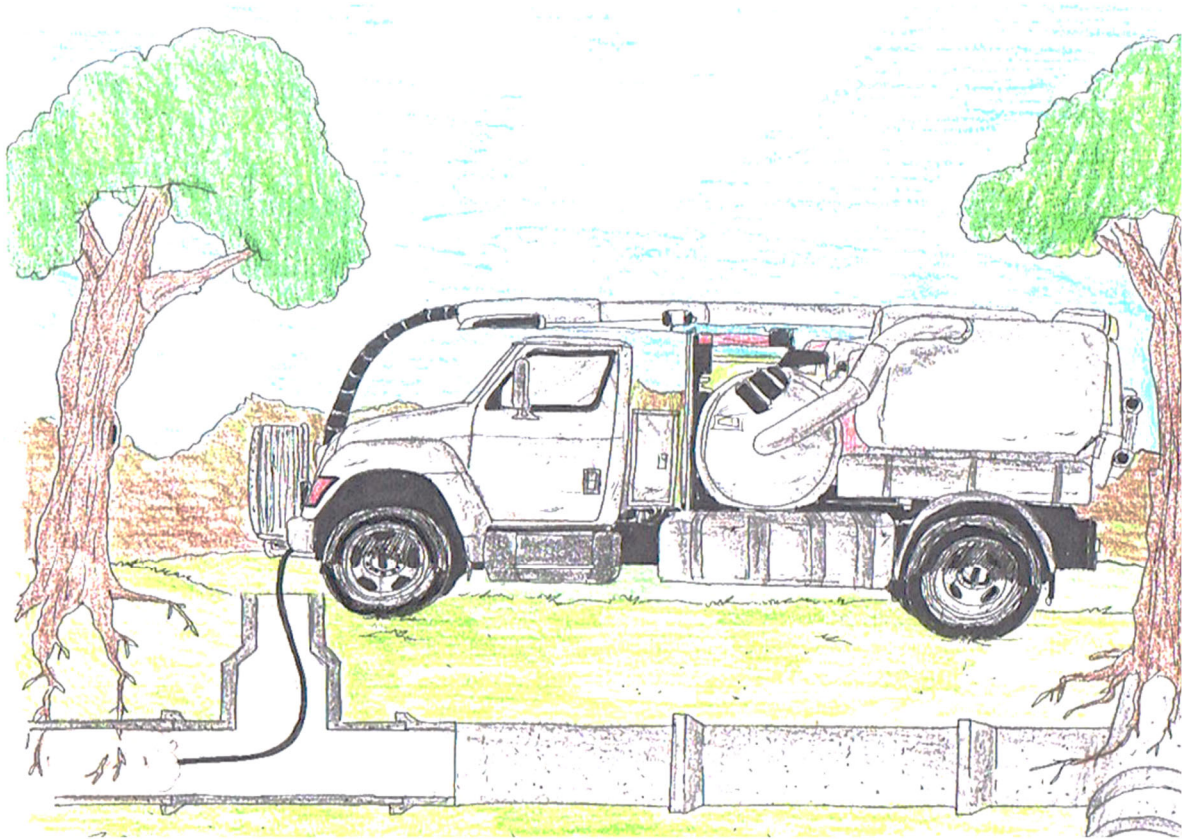

The best method of controlling hydrogen sulfide is to eliminate its habitat or growth area by keeping sewers cleaner, this will harbor fewer slime bacteria.

## Electrical Motor Sub-Section - Introduction

The power source of the pump is usually an electric motor. The motor is connected by a coupling to the pump shaft. The purpose of the bearings is to hold the shaft firmly in place, yet allow it to rotate. The bearing house supports the bearings and provides a reservoir for the lubricant. An impeller is connected to the shaft. The pump assembly can be a vertical or horizontal set-up; the components for both are basically the same.

### Motors

The purpose of this discussion on pump motors is to identify and describe the main types of motors, starters, enclosures and motor controls, as well as to provide you with some basic maintenance and troubleshooting information. Although pumps may be driven by diesel or gasoline engines, pumps driven by electric motors are commonly used in our industry.

**There are two general categories of electric motors:**

- ✱ D-C motors, or direct current
- ✱ A-C motors, or alternating current

You can expect most motors at facilities to be A-C type.

### D-C Motors

The important characteristic of the D-C motor is that its speed will vary with the amount of voltage used. There are many different kinds of D-C motors, depending on how they are wound and their speed/torque characteristics.



### A-C Motors

There are a number of different types of alternating current motors, such as Synchronous, Induction, wound rotor, and squirrel cage. The synchronous type of A-C motor requires complex control equipment, since they use a combination of A-C and D-C. This also means that the synchronous type of A-C motor is used in large horsepower sizes, usually above 250 HP. The induction type motor uses only alternating current. The squirrel cage motor provides a relatively constant speed. The wound rotor type could be used as a variable speed motor.

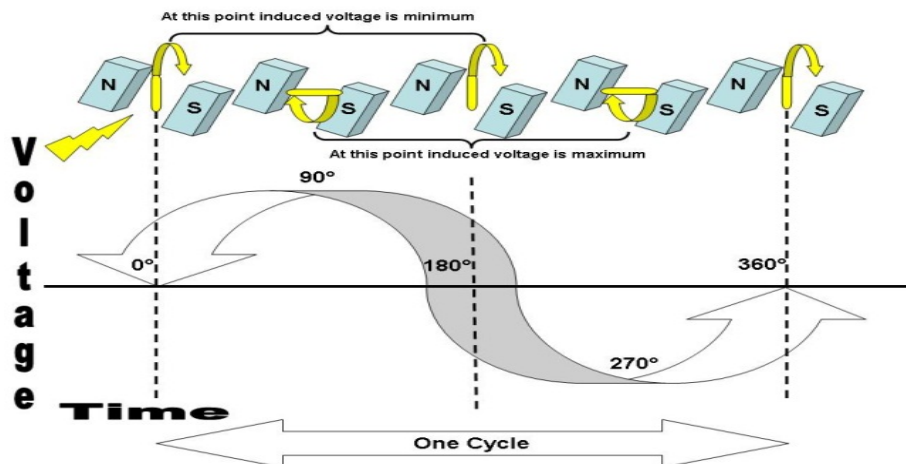

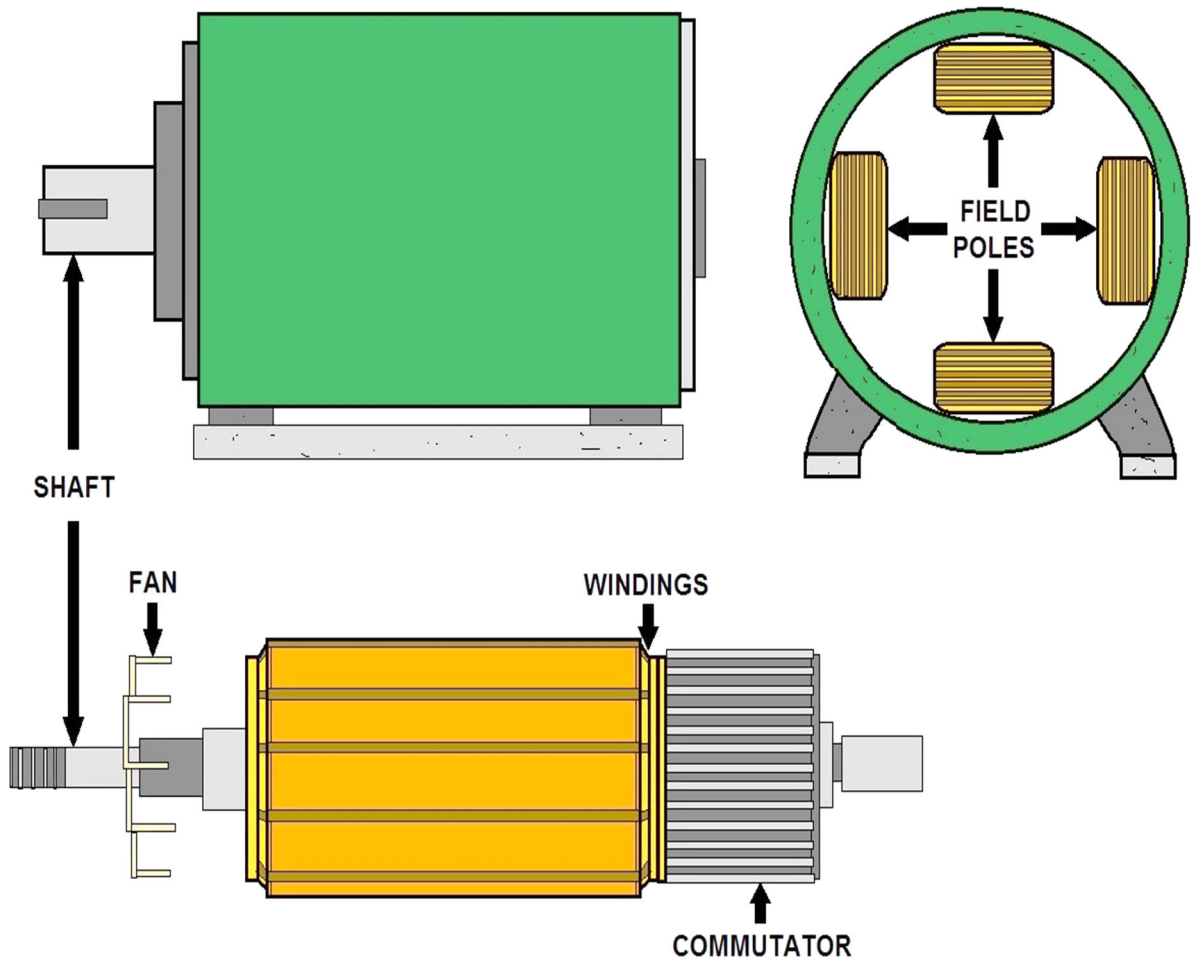

**DC ELECTRIC MOTOR DIAGRAM EXAMPLE**

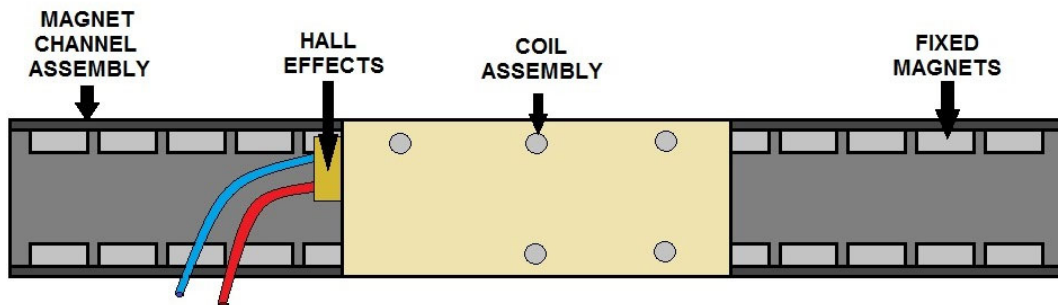

**LINEAR MOTOR**

Electric Induction Motor that produces Straight-Line motion by means of a Linear Stator and Rotor placed in Parallel



**Define the Following Terms:**

Voltage:

EMF:

Power:

Current:

Resistance:

Conductor:

Phase:

Single Phase:

Three Phase:

Hertz:

**Motor Starters**

All electric motors, except very small ones such as chemical feed pumps, are equipped with starters, either full voltage or reduced voltage. This is because motors draw a much higher current when they are starting and gaining speed. The purpose of the reduced voltage starter is to prevent the load from coming on until the amperage is low enough.

**Motor Enclosures**

Depending on the application, motors may need special protection. Some motors are referred to as open motors. They allow air to pass through to remove heat generated when current passes through the windings. Other motors use specific enclosures for special environments or safety protection.

Can you think of any locations within your facility that requires special enclosures?



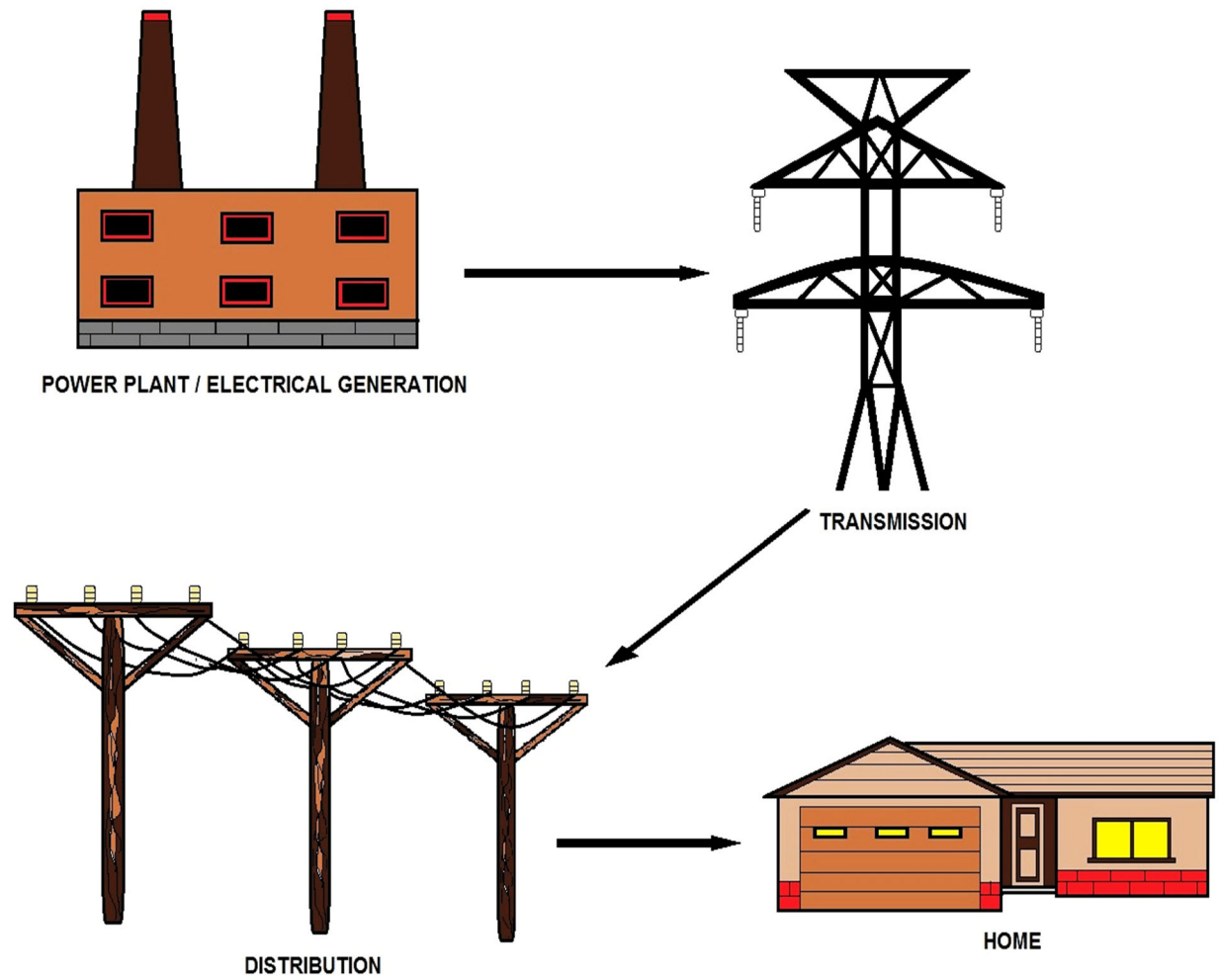

## HOW ELECTRICITY GETS TO CONSUMERS (USERS)

## Two Types of Totally Enclosed Motors Commonly Used

- ☞ **TENV**, or totally enclosed non-ventilated motor
- ☞ **TEFC**, or totally enclosed fan cooled motor

Totally enclosed motors include dust-proof, water-proof and explosion-proof motors. An explosion proof enclosure must be provided on any motor where dangerous gases might accumulate.



### Motor Controls

All pump motors are provided with some method of control, typically a combination of manual and automatic. Manual pump controls can be located at the central control panel, at the pump, or at the suction or discharge points of the liquid being pumped.

There are a number of ways in which automatic control of a pump motor can be regulated:

- ☛ Pressure and vacuum sensors
- ☛ Preset time intervals
- ☛ Flow sensors
- ☛ Level sensors

Two typical level sensors are the float sensor and the bubble regulator. The float sensor is pear-shaped and hangs in the wet well.

As the height increases, the float tilts, and the mercury in the glass tube flows toward the end of the tube that has two wires attached to it. When the mercury covers the wires, it closes the circuit.



For a bubbler level sensor, a low pressure air supply is allowed to escape from a bubbler pipe in the wet well. The back-pressure on the air supply will vary with the liquid level over the pipe. Sensitive air pressure switches will detect this change and use this information to control pump operation.

### Motor Maintenance

Motors should be kept clean, free of moisture, and lubricated properly. Dirt, dust, and grime will plug the ventilating spaces and can actually form an insulating layer over the metal surface of the motor.

***What condition would occur if the ventilation becomes blocked?***

## Moisture

Moisture harms the insulation on the windings to the point where they may no longer provide the required insulation for the voltage applied to the motor. In addition, moisture on windings tend to absorb acid and alkali fumes, causing damage to both insulation and metals. To reduce problems caused by moisture, the most suitable motor enclosure for the existing environment will normally be used. It is recommended to run stand by motors to dry up any condensation which accumulates in the motor.

## Motor Lubrication

Friction will cause wear in all moving parts, and lubrication is needed to reduce this friction. It is very important that all your manufacturer's recommended lubrication procedures are strictly followed. You have to be careful not to add too much grease or oil, as this could cause more friction and generate heat.

### **To grease the motor bearings, this is the usual approach:**

1. Remove the protective plugs and caps from the grease inlet and relief holes.
2. Pump grease in until fresh starts coming from the relief hole.

If fresh grease does not come out of the relief hole, this could mean that the grease has been pumped into the motor windings. The motor must then be taken apart and cleaned by a qualified service representative.

### **To change the oil in an oil lubricated motor, this is the usual approach:**

1. Remove all plugs and let the oil drain.
2. Check for metal shearing (pieces of metal in the oil.)
3. Replace the oil drain.
4. Add new oil until it is up to the oil level plug.
5. Replace the oil level and filter plug.

Never mix oils, since the additives of different oils when combined can cause breakdown of the oil.

## Type of Motor Commutation

Self-Commutated		Externally Commutated		
Mechanical-Commutator Motors		Electronic-Commutator (EC) Motors	Asynchronous Machines	Synchronous Machines
AC	DC	AC	AC	
<ul style="list-style-type: none"> <li>• Universal motor (AC commutator series motor or AC/DC motor)</li> <li>• Repulsion motor</li> </ul>	<p>Electrically excited DC motor:</p> <ul style="list-style-type: none"> <li>• Separately excited</li> <li>• Series</li> <li>• Shunt</li> <li>• Compound</li> </ul> <p>PM DC motor</p>	<p>With PM rotor:</p> <ul style="list-style-type: none"> <li>• BLDC motor</li> </ul> <p>With ferromagnetic rotor:</p> <ul style="list-style-type: none"> <li>• SRM</li> </ul>	<p>Three-phase motors:</p> <ul style="list-style-type: none"> <li>• SCIM</li> <li>• WRIM</li> </ul> <p>AC motors:</p> <ul style="list-style-type: none"> <li>• Capacitor</li> <li>• Resistance</li> <li>• Split</li> <li>• Shaded-pole</li> </ul>	<p>Three-phase motors:</p> <ul style="list-style-type: none"> <li>• WRSM</li> <li>• PMSM or BLAC motor                             <ul style="list-style-type: none"> <li>○ IPMSM</li> <li>○ SPMSM</li> </ul> </li> <li>• Hybrid</li> </ul> <p>AC motors:</p> <ul style="list-style-type: none"> <li>• Permanent-split capacitor</li> <li>• Hysteresis</li> <li>• Stepper</li> <li>• SyRM</li> <li>• SyRM-PM hybrid</li> </ul>
Simple electronics	Rectifier, linear transistor(s) or DC chopper	More elaborate electronics	Most elaborate electronics (VFD), when provided	

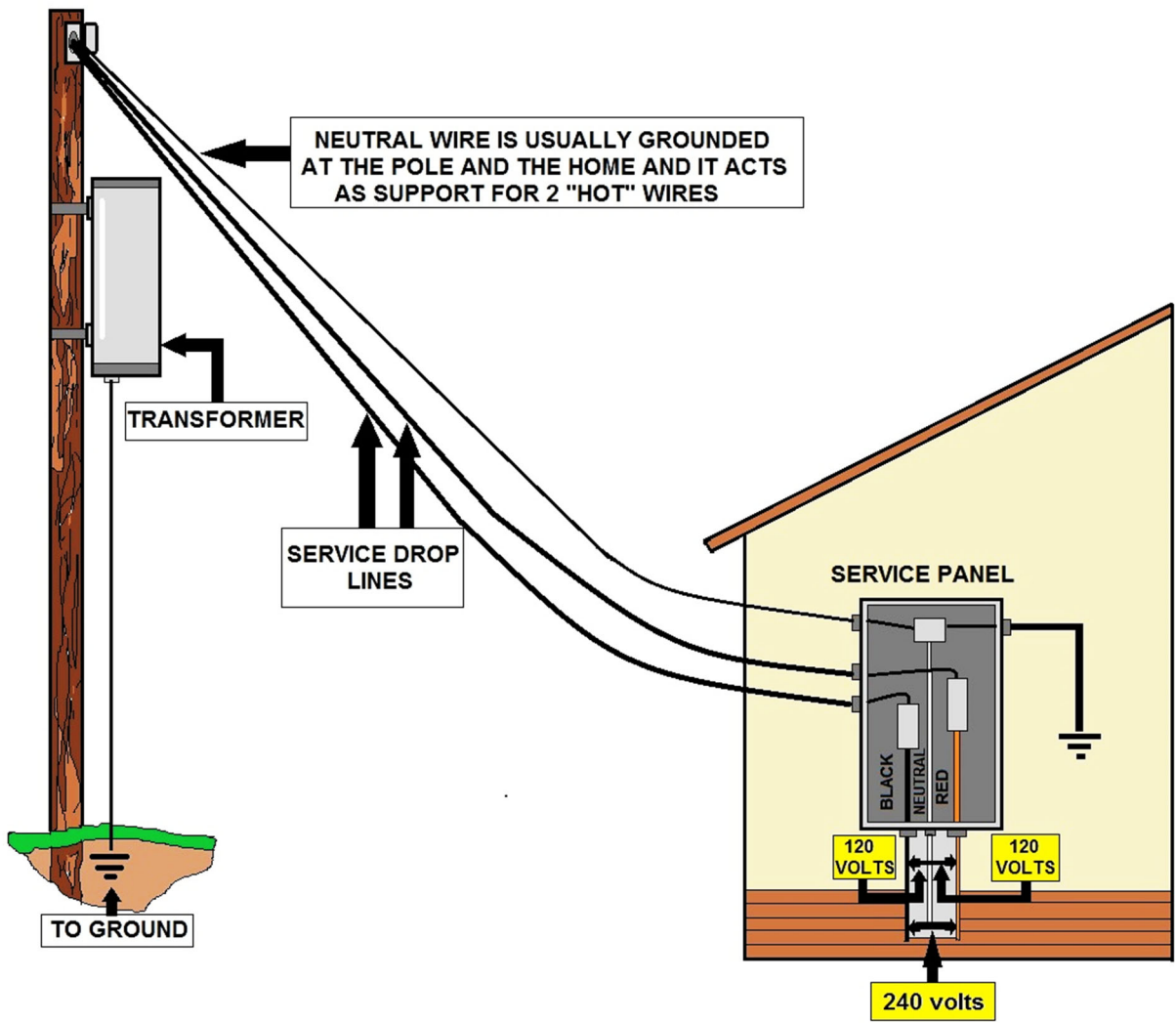

**BASIC HOME ELECTRICITY  
(120/240 VOLTS)**

## Understanding Motors

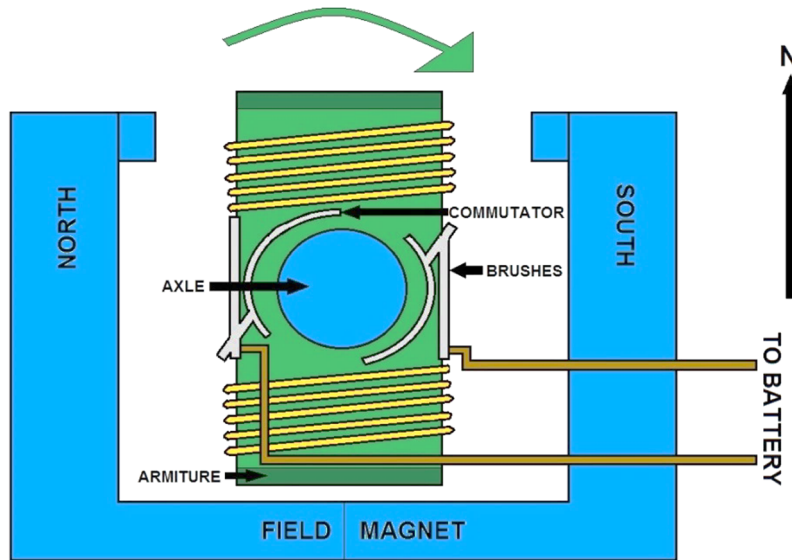

The classic division of electric motors has been that of Direct Current (DC) types vs. Alternating Current (AC) types. This is more a de facto convention, rather than a rigid distinction. For example, many classic DC motors run happily on AC power.

The ongoing trend toward electronic control further muddles the distinction; as modern drivers have moved the commutator out of the motor shell. For this new breed of motor, driver circuits are relied upon to generate sinusoidal AC drive currents, or some approximation of. The two best examples are: the brushless DC motor and the stepping motor, both being polyphase AC motors requiring external electronic control.

There is a clearer distinction between a synchronous motor and asynchronous types. In the synchronous types, the rotor rotates in synchrony with the oscillating field or current (e.g. permanent magnet motors). In contrast, an asynchronous motor is designed to slip; the most ubiquitous example being the common AC induction motor which must slip in order to generate torque.

A DC motor is designed to run on DC electric power. Two examples of pure DC designs are Michael Faraday's homopolar motor (which is uncommon), and the ball bearing motor, which is (so far) a novelty. By far the most common DC motor types are the brushed and brushless types, which use internal and external commutation respectively to create an oscillating AC current from the DC source -- so they are not purely DC machines in a strict sense.

### Brushed DC motors

The classic DC motor design generates an oscillating current in a wound rotor with a split ring commutator, and either a wound or permanent magnet stator. A rotor consists of a coil wound around a rotor which is then powered by any type of battery. Many of the limitations of the classic commutator DC motor are due to the need for brushes to press against the commutator. This creates friction.

At higher speeds, brushes have increasing difficulty in maintaining contact. Brushes may bounce off the irregularities in the commutator surface, creating sparks. This limits the maximum speed of the machine.

The current density per unit area of the brushes limits the output of the motor. The imperfect electric contact also causes electrical noise. Brushes eventually wear out and require replacement, and the commutator itself is subject to wear and maintenance. The commutator assembly on a large machine is a costly element, requiring precision assembly of many parts.

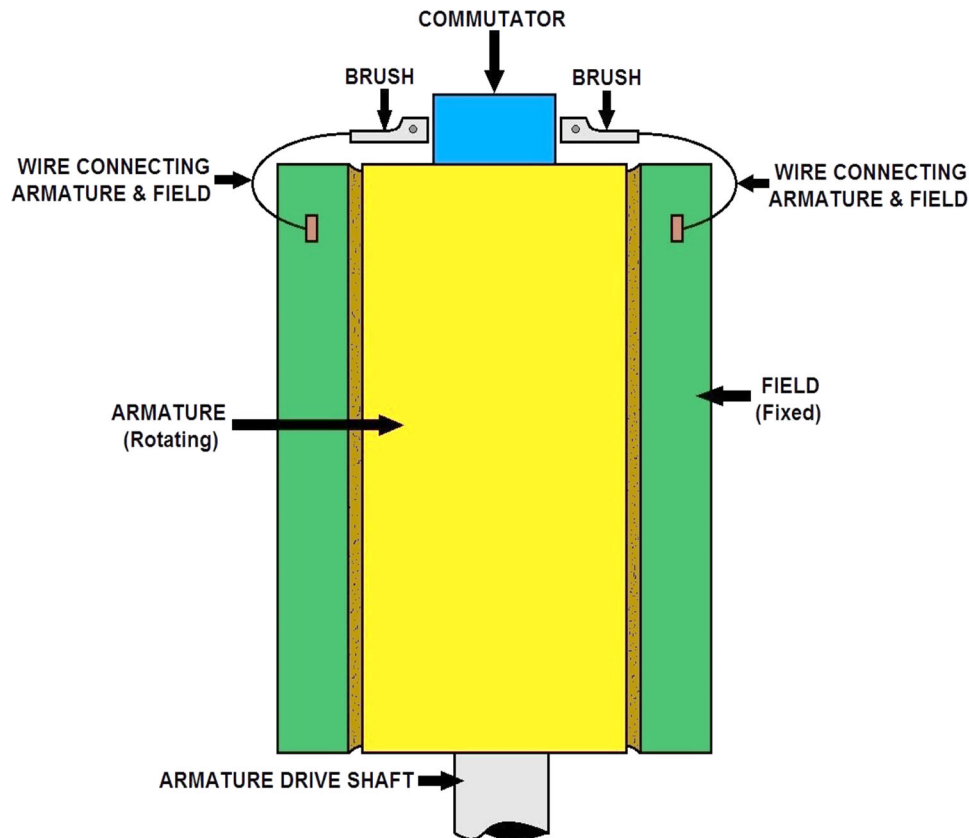

**DIAGRAM SHOWING MECHANICAL CONSTRUCTION  
OF A DC SERIES WOUND MOTOR**

### **Brushless DC Motors**

Some of the problems of the brushed DC motor are eliminated in the brushless design. In this motor, the mechanical "rotating switch" or commutator/brush gear assembly is replaced by an external electronic switch synchronized to the rotor's position. Brushless motors are typically 85-90% efficient, whereas DC motors with brush gear are typically 75-80% efficient.

Midway between ordinary DC motors and stepper motors lies the realm of the brushless DC motor. Built in a fashion very similar to stepper motors, these often use a permanent magnet external rotor, three phases of driving coils, one or more Hall Effect sensors to sense the position of the rotor, and the associated drive electronics.



The coils are activated one phase after the other by the drive electronics, as cued by the signals from the Hall effect sensors. In effect, they act as three-phase synchronous motors containing their own variable-frequency drive electronics. Brushless DC motors are commonly used where precise speed control is necessary, as in computer disk drives or in video cassette recorders, the spindles within CD, CD-ROM (etc.) drives, and mechanisms within office products such as fans, laser printers, and photocopiers.

**They have several advantages over conventional motors:**

- \* Compared to AC fans using shaded-pole motors, they are very efficient, running much cooler than the equivalent AC motors. This cool operation leads to much-improved life of the fan's bearings.
- \* Without a commutator to wear out, the life of a DC brushless motor can be significantly longer compared to a DC motor using brushes and a commutator. Commutation also tends to cause a great deal of electrical and RF noise; without a commutator or brushes, a brushless motor may be used in electrically sensitive devices like audio equipment or computers.
- \* The same Hall Effect sensors that provide the commutation can also provide a convenient tachometer signal for closed-loop control (servo-controlled) applications. In fans, the tachometer signal can be used to derive a "fan OK" signal.
- \* The motor can be easily synchronized to an internal or external clock, leading to precise speed control.
- \* Brushless motors have no chance of sparking, unlike brushed motors, making them better suited to environments with volatile chemicals and fuels.
- \* Brushless motors are usually used in small equipment such as computers, and are generally used to get rid of unwanted heat.
- \* They are also very quiet motors, which is an advantage if being used in equipment that is affected by vibrations.

Modern DC brushless motors range in power from a fraction of a watt to many kilowatts. Larger brushless motors up to about 100 kW rating are used in electric vehicles. They also find significant use in high-performance electric model aircraft.

**Coreless DC Motors**

Nothing in the design of any of the motors described above requires that the iron (steel) portions of the rotor actually rotate; torque is exerted only on the windings of the electromagnets. Taking advantage of this fact is the coreless DC motor, a specialized form of a brush or brushless DC motor. Optimized for rapid acceleration, these motors have a rotor that is constructed without any iron core. The rotor can take the form of a winding-filled cylinder inside the stator magnets, a basket surrounding the stator magnets, or a flat pancake (possibly formed on a printed wiring board) running between upper and lower stator magnets.

The windings are typically stabilized by being impregnated with electrical epoxy potting systems. Filled epoxies that have moderate mixed viscosity and a long gel time. These systems are highlighted by low shrinkage and low exotherm.

Because the rotor is much lighter in weight (mass) than a conventional rotor formed from copper windings on steel laminations, the rotor can accelerate much more rapidly, often achieving a mechanical time constant under 1 ms. This is especially true if the windings use aluminum rather than the heavier copper. But because there is no metal mass in the rotor to act as a heat sink, even small coreless motors must often be cooled by forced air.

These motors were commonly used to drive the capstan(s) of magnetic tape drives and are still widely used in high-performance servo-controlled systems, like radio-controlled vehicles/aircraft, humanoid robotic systems, industrial automation, medical devices, etc.

### **Universal Motors**

A variant of the wound field DC motor is the universal motor. The name derives from the fact that it may use AC or DC supply current, although in practice they are nearly always used with AC supplies.

The principle is that in a wound field DC motor the current in both the field and the armature (and hence the resultant magnetic fields) will alternate (reverse polarity) at the same time, and hence the mechanical force generated is always in the same direction. In practice, the motor must be specially designed to cope with the AC current (impedance must be taken into account, as must the pulsating force), and the resultant motor is generally less efficient than an equivalent pure DC motor.

Operating at normal power line frequencies, the maximum output of universal motors is limited and motors exceeding one kilowatt are rare. But universal motors also form the basis of the traditional railway traction motor in electric railways. In this application, to keep their electrical efficiency high, they were operated from very low frequency AC supplies, with 25 Hz and 16 2/3 hertz operation being common. Because they are universal motors, locomotives using this design were also commonly capable of operating from a third rail powered by DC.

The advantage of the universal motor is that AC supplies may be used on motors which have the typical characteristics of DC motors, specifically high starting torque and very compact design if high running speeds are used. The negative aspect is the maintenance and short life problems caused by the commutator. As a result, such motors are usually used in AC devices such as food mixers and power tools which are used only intermittently.

Continuous speed control of a universal motor running on AC is very easily accomplished using a thyristor circuit, while stepped speed control can be accomplished using multiple taps on the field coil. Household blenders that advertise many speeds frequently combine a field coil with several taps and a diode that can be inserted in series with the motor (causing the motor to run on half-wave rectified AC).

## AC Motor Sub-Section

In 1882, Nicola Tesla identified the rotating magnetic field principle, and pioneered the use of a rotary field of force to operate machines. He exploited the principle to design a unique two-phase induction motor in 1883. In 1885, Galileo Ferraris independently researched the concept. In 1888, Ferraris published his research in a paper to the Royal Academy of Sciences in Turin.

Introduction of Tesla's motor from 1888 onwards initiated what is sometimes referred to as the Second Industrial Revolution, making possible the efficient generation and long distance distribution of electrical energy using the alternating current transmission system, also of Tesla's invention (1888). Before the invention of the rotating magnetic field, motors operated by continually passing a conductor through a stationary magnetic field (as in homopolar motors). Tesla had suggested that the commutators from a machine could be removed and the device could operate on a rotary field of force. Professor Poeschel, his teacher, stated that would be akin to building a perpetual motion machine.

### Components

**A typical AC motor consists of two parts:**

1. An outside stationary stator having coils supplied with AC current to produce a rotating magnetic field, and;
2. An inside rotor attached to the output shaft that is given a torque by the rotating field.

### Torque motors

A torque motor is a specialized form of induction motor which is capable of operating indefinitely at stall (with the rotor blocked from turning) without damage. In this mode, the motor will apply a steady stall torque to the load (hence the name).

A common application of a torque motor would be the supply- and take-up reel motors in a tape drive. In this application, driven from a low voltage, the characteristics of these motors allow a relatively-constant light tension to be applied to the tape whether or not the capstan is feeding tape past the tape heads.

Driven from a higher voltage, (and so delivering a higher torque), the torque motors can also achieve fast-forward and rewind operation without requiring any additional mechanics such as gears or clutches. In the computer world, torque motors are used with force feedback steering wheels.

### Slip Ring

The slip ring or wound rotor motor is an induction machine where the rotor comprises a set of coils that are terminated in slip rings to which external impedances can be connected. The stator is the same as is used with a standard squirrel cage motor. By changing the impedance connected to the rotor circuit, the speed/current and speed/torque curves can be altered.

The slip ring motor is used primarily to start a high inertia load or a load that requires a very high starting torque across the full speed range. By correctly selecting the resistors used in the secondary resistance or slip ring starter, the motor is able to produce maximum torque at a relatively low current from zero speed to full speed. A secondary use of the slip ring motor is to provide a means of speed control.

Because the torque curve of the motor is effectively modified by the resistance connected to the rotor circuit, the speed of the motor can be altered. Increasing the value of resistance on the rotor circuit will move the speed of maximum torque down.

If the resistance connected to the rotor is increased beyond the point where the maximum torque occurs at zero speed, the torque will be further reduced. When used with a load that has a torque curve that increases with speed, the motor will operate at the speed where the torque developed by the motor is equal to the load torque.

Reducing the load will cause the motor to speed up, and increasing the load will cause the motor to slow down until the load and motor torque are equal. Operated in this manner, the slip losses are dissipated in the secondary resistors and can be very significant. The speed regulation is also very poor.

### **Stepper Motors**

Closely related in design to three-phase AC synchronous motors are stepper motors, where an internal rotor containing permanent magnets or a large iron core with salient poles is controlled by a set of external magnets that are switched electronically.

A stepper motor may also be thought of as a cross between a DC electric motor and a solenoid. As each coil is energized in turn, the rotor aligns itself with the magnetic field produced by the energized field winding.

Unlike a synchronous motor, in its application, the motor may not rotate continuously; instead, it "steps" from one position to the next as field windings are energized and de-energized in sequence. Depending on the sequence, the rotor may turn forwards or backwards.

Simple stepper motor drivers entirely energize or entirely de-energize the field windings, leading the rotor to "cog" to a limited number of positions; more sophisticated drivers can proportionally control the power to the field windings, allowing the rotors to position between the cog points and thereby rotate extremely smoothly.

Computer controlled stepper motors are one of the most versatile forms of positioning systems, particularly when part of a digital servo-controlled system.

Stepper motors can be rotated to a specific angle with ease, and hence stepper motors are used in pre-gigabyte era computer disk drives, where the precision they offered was adequate for the correct positioning of the read/write head of a hard disk drive. As drive density increased, the precision limitations of stepper motors made them obsolete for hard drives, thus newer hard disk drives use read/write head control systems based on voice coils. Stepper motors were upscaled to be used in electric vehicles under the term SRM (switched reluctance machine).

## Reviewing A-C Motors

### AC Motor History

In 1882, Nikola Tesla discovered the rotating magnetic field, and pioneered the use of a rotary field of force to operate machines. He exploited the principle to design a unique two-phase induction motor in 1883. In 1885, Galileo Ferraris independently researched the concept. In 1888, Ferraris published his research in a paper to the Royal Academy of Sciences in Turin. Tesla had suggested that the commutators from a machine could be removed and the device could operate on a rotary field of force. Professor Poeschel, his teacher, stated that would be akin to building a perpetual motion machine.

Michail Osipovich Dolivo-Dobrovolsky later developed a three-phase "cage-rotor" in 1890. This type of motor is now used for the vast majority of commercial applications.

An AC motor has two parts: a stationary stator having coils supplied with alternating current to produce a rotating magnetic field, and a rotor attached to the output shaft that is given a torque by the rotating field.

### AC Motor with Sliding Rotor

A conical-rotor brake motor incorporates the brake as an integral part of the conical sliding rotor. When the motor is at rest, a spring acts on the sliding rotor and forces the brake ring against the brake cap in the motor, holding the rotor stationary. When the motor is energized, its magnetic field generates both an axial and a radial component. The axial component overcomes the spring force, releasing the brake; while the radial component causes the rotor to turn. There is no additional brake control required.

### Synchronous Electric Motor

A synchronous electric motor is an AC motor distinguished by a rotor spinning with coils passing magnets at the same rate as the alternating current and resulting magnetic field which drives it. Another way of saying this is that it has zero slip under usual operating conditions. Contrast this with an induction motor, which must slip to produce torque. One type of synchronous motor is like an induction motor except the rotor is excited by a DC field. Slip rings and brushes are used to conduct current to the rotor. The rotor poles connect to each other and move at the same speed hence the name synchronous motor.

Another type, for low load torque, has flats ground onto a conventional squirrel-cage rotor to create discrete poles. Yet another, such as made by Hammond for its pre-World War II clocks, and in the older Hammond organs, has no rotor windings and discrete poles. It is not self-starting. The clock requires manual starting by a small knob on the back, while the older Hammond organs had an auxiliary starting motor connected by a spring-loaded manually operated switch.

Finally, hysteresis synchronous motors typically are (essentially) two-phase motors with a phase-shifting capacitor for one phase. They start like induction motors, but when slip rate decreases sufficiently, the rotor (a smooth cylinder) becomes temporarily magnetized.

Its distributed poles make it act like a permanent-magnet-rotor synchronous motor. The rotor material, like that of a common nail, will stay magnetized, but can also be demagnetized with little difficulty. Once running, the rotor poles stay in place; they do not drift.

Low-power synchronous timing motors (such as those for traditional electric clocks) may have multi-pole permanent-magnet external cup rotors, and use shading coils to provide starting torque. Telechron clock motors have shaded poles for starting torque, and a two-spoke ring rotor that performs like a discrete two-pole rotor.

### **Induction Motor**

An induction motor is an asynchronous AC motor where power is transferred to the rotor by electromagnetic induction, much like transformer action. An induction motor resembles a rotating transformer, because the stator (stationary part) is essentially the primary side of the transformer and the rotor (rotating part) is the secondary side. Polyphase induction motors are widely used in industry.

Induction motors may be further divided into squirrel-cage motors and wound-rotor motors. Squirrel-cage motors have a heavy winding made up of solid bars, usually aluminum or copper, joined by rings at the ends of the rotor. When one considers only the bars and rings as a whole, they are much like an animal's rotating exercise cage, hence the name.

Currents induced into this winding provide the rotor magnetic field. The shape of the rotor bars determines the speed-torque characteristics. At low speeds, the current induced in the squirrel cage is nearly at line frequency and tends to be in the outer parts of the rotor cage. As the motor accelerates, the slip frequency becomes lower, and more current is in the interior of the winding. By shaping the bars to change the resistance of the winding portions in the interior and outer parts of the cage, effectively a variable resistance is inserted in the rotor circuit. However, the majority of such motors have uniform bars.

In a wound-rotor motor, the rotor winding is made of many turns of insulated wire and is connected to slip rings on the motor shaft. An external resistor or other control devices can be connected in the rotor circuit. Resistors allow control of the motor speed, although significant power is dissipated in the external resistance. A converter can be fed from the rotor circuit and return the slip-frequency power that would otherwise be wasted back into the power system through an inverter or separate motor-generator.

The wound-rotor induction motor is used primarily to start a high inertia load or a load that requires a very high starting torque across the full speed range. By correctly selecting the resistors used in the secondary resistance or slip ring starter, the motor is able to produce maximum torque at a relatively low supply current from zero speed to full speed. This type of motor also offers controllable speed.

Motor speed can be changed because the torque curve of the motor is effectively modified by the amount of resistance connected to the rotor circuit. Increasing the value of resistance will move the speed of maximum torque down. If the resistance connected to the rotor is increased beyond the point where the maximum torque occurs at zero speed, the torque will be further reduced.

When used with a load that has a torque curve that increases with speed, the motor will operate at the speed where the torque developed by the motor is equal to the load torque. Reducing the load will cause the motor to speed up, and increasing the load will cause the motor to slow down until the load and motor torque are equal. Operated in this manner, the slip losses are dissipated in the secondary resistors and can be very significant.

## Electric Motor Maintenance Sub-Section

### General

Make a habit of checking that the motor is securely bolted to its platform. Mounting bolts can vibrate loose. Check to see that rotating parts aren't rubbing on stationary parts of the motor, causing damage to the motor.

Remember that an electric motor is an air-cooled piece of equipment and needs all the ventilation it can get. Excessive heat is a main cause of reduced motor life.

Motors also like to be dry. Keep motor windings dry by keeping pump packing in good condition. Even if windings are protected from moisture, minerals in the pumped water can attach to the windings and cause early failure. Motors that operate at 3600 rpm experience twice as much wear as motors operating at 1800 rpm. Regular maintenance is especially critical for 3600 rpm motors and pumps.

### Maintenance Tasks

#### At season startup:

- Remove tape on all openings and clean out rodents, insects, or debris.
- Locate the motor drain hole on the base or support for the base, and clean it out so water won't be trapped and held directly under the air intake.
- Change oil in reduced voltage starters, using an oil recommended by the manufacturer. Be sure to clean the oil pan before refilling.
- Use vacuum suction or air pressure to remove dust and debris from moving parts of the motor. (Don't exceed 50 psi of air pressure.)

#### Periodically:

- Clean grass or debris from air ventilation openings on the motor and from around the motor to allow a full flow of cooling air.
- Check screens on motor ventilation openings. Replace with machine cloth (¼-inch mesh) as necessary.

#### At end of season shutdown:

- Cover the motor with a breathable water-resistant tarp.

### Motor Electrical System

Wide temperature fluctuations during the year can cause electrical connections (especially in aluminum wire) to expand and contract, loosening connectors. Loose electrical connections cause heat buildup and arcing at electrical terminals. The voltage drop across loose connections will cause the motor to operate at less than its rated voltage, increasing internal motor temperature. Increased heat will break down motor winding insulation, resulting in electrical shorts and motor failures. A loose or broken connection can also unbalance the phases of three-phase power and damage the motor windings.

**Caution:** Before conducting these tasks, be sure power is off at the utility disconnect switch. It may be necessary to have the utility company shut the power off.

### Maintenance Tasks

#### At season startup:

- Inspect insulation of motor windings. If the windings are excessively grease-covered, consult your motor repair shop for direction.
- Check all safety switches according to the manufacturer's directions.

**Twice a year:**

- Check electrical connections from meter loop to motor for corrosion and clean if necessary.
- Coat the wiring (especially aluminum) and connectors with an antioxidant that meets electrical code requirements.
- Check electrical connections from the meter loop to the motor for tightness.
- Tighten and re-tape if necessary.
- Replace overheated connections or wires with new material. Overheated connections will show heat damage such as burnt insulation on wires.

**Motor Bearings**

Lubricate the motor according to the manufacturer's instructions. Intervals between lubrication will vary with motor speed, power draw, load, ambient temperatures, exposure to moisture, and seasonal or continuous operation. Electric motors should not be greased daily. Bearings can be ruined by either over- or under-greasing.

Fill a grease gun with electric motor bearing grease and label it so it won't be confused with other types of lubricating grease.

**Maintenance Tasks**

Change the grease at recommended intervals to remove any accumulated moisture:

- Remove the bottom relief plug and clean hardened grease out of passageway.
- Using a grease gun, fill the housing with approved high temperature electric motor bearing grease (refer to the manufacturer's manual for API number of grease) until old grease is expelled.

**Caution:** If old grease is not expelled as the new grease is pumped in, stop adding grease and have your motor checked by a qualified repair person. Adding new grease without old grease being removed could blow the seals and push grease into the motor windings, causing the motor to overheat and reducing its service life. Do not over-grease your motor.

- Run motor until all surplus grease is thrown out through the bottom grease port (may require 5 to 10 minutes).
- Shut off the motor and use a screwdriver or similar device to remove a small amount of grease from the grease port to allow for grease expansion during full load operation.
- Replace grease plug.

**Control Panel Maintenance****Control Panel Safety Precautions**

Never use the main disconnect to start or stop your motor. It is not intended for this purpose. Using the main disconnect to start and stop the motor will cause excessive wear of the contacts and arcing can occur. Use the start and stop button.

If the overhead lines to your control panel's service are obstructed by tree branches or other items, have the utility company clear the lines.

**Have an electrician inspect your panel to ensure that:**

- Control circuits are protected with the correct size and type of fuse.
- Lightning arresters are properly installed on the meter and motor side of the buss and breaker. They should also be mounted in a secure box to protect you if they blow up.
- The service panel is properly grounded, independently of the pumping plant.
- Service head grommets are in place and in good condition.



### **General Maintenance**

Have your electrician or pump maintenance person do a Megger check on the control panel, motor, conduits, and other electrical connections. The Megger device applies a small amount of voltage to an electrical component and measures the electrical resistance. A Megger test can also detect potentially harmful moisture in windings.

Any time the main disconnect switch has been left open or off, operate it several times before leaving it closed or on. Copper oxide can form in a few hours and result in poor contact and overheating. Any type of corrosion can cause poor contact, poor grounding, and direct or high-resistance shorts.

**Caution:** After opening the control panel but before touching the controls inside, use a voltmeter to be sure that the incoming power is disconnected or turned off. If necessary, have your utility disconnect the power. If you have any doubts about the safety of your control panel, WALK AWAY AND CALL A QUALIFIED ELECTRICIAN.

Even a current of 15 milliamps (one milliamp is one one-thousandth of an amp) can cause serious injury or death. Always play it safe!



## Pump Definitions

### Hyperlink to the Glossary and Appendix

<http://www.abctlc.com/downloads/PDF/PumpGlossary.pdf>

**Fluid:** Any substance that can be pumped such as oil, water, refrigerant, or even air.

**Gasket:** Flat material that is compressed between two flanges or faces to form a seal.

**Gland follower:** A bushing used to compress the packing in the stuffing box and to control leakoff.

**Gland sealing line:** A line that directs sealing fluid to the stuffing box.

**Horizontal pumps:** Pumps in which the center line of the shaft is horizontal.

**Impeller:** The part of the pump that increases the speed of the fluid being handled.

**Inboard:** The end of the pump closest to the motor.

**Inter-stage diaphragm:** A barrier that separates stages of a multi-stage pump.

**Key:** A rectangular piece of metal that prevents the impeller from rotating on the shaft.

**Keyway:** The area on the shaft that accepts the key.

**Kinetic energy:** Energy associated with motion.

**Lantern ring:** A metal ring located between rings of packing that distributes gland sealing fluid.

**Leak-off:** Fluid that leaks from the stuffing box.

**Mechanical seal:** A mechanical device that seals the pump stuffing box.

**Mixed flow pump:** A pump that uses both axial-flow and radial-flow components in one impeller.

**Multi-stage pumps:** Pumps with more than one impeller.

**Outboard:** The end of the pump farthest from the motor.

**Packing:** Soft, pliable material that seals the stuffing box.

**Positive displacement pumps:** Pumps that move fluids by physically displacing the fluid inside the pump.

**Radial bearings:** Bearings that prevent shaft movement in any direction outward from the center line of the pump.

**Radial flow:** Flow at 90° to the center line of the shaft.

**Retaining nut:** A nut that keeps the parts in place.

**Rotor:** The rotating parts, usually including the impeller, shaft, bearing housings, and all other parts included between the bearing housing and the impeller.

**Score:** To cause lines, grooves, or scratches.

**Shaft:** A cylindrical bar that transmits power from the driver to the pump impeller.

**Shaft sleeve:** A replaceable tubular covering on the shaft.

**Shroud:** The metal covering over the vanes of an impeller.

**Slop drain:** The drain from the area that collects leak-off from the stuffing box.

**Slurry:** A thick, viscous fluid, usually containing small particles.

**Stages:** Impellers in a multi-stage pump.

**Stethoscope:** A metal device that can amplify and pinpoint pump sounds.

**Strainer:** A device that retains solid pieces while letting liquids through.

**Stuffing box:** The area of the pump where the shaft penetrates the casing.

**Suction:** The place where fluid enters the pump.

**Suction eye:** The place where fluid enters the pump impeller.

**Throat bushing:** A bushing at the bottom of the stuffing box that prevents packing from being pushed out of the stuffing box into the suction eye of the impeller.

**Thrust:** Force, usually along the center line of the pump.

**Thrust bearings:** Bearings that prevent shaft movement back and forth in the same direction as the center line of the shaft.

**Troubleshooting:** Locating a problem.

**Vanes:** The parts of the impeller that push and increase the speed of the fluid in the pump.

**Vertical pumps:** Pumps in which the center line of the shaft runs vertically.

**Volute:** The part of the pump that changes the speed of the fluid into pressure.

**Wearing rings:** Replaceable rings on the impeller or the casing that wear as the pump operates.

## Post Quiz

1. \_\_\_\_\_ are rapidly replacing conventional packing as the means of controlling leakage on rotary and positive-displacement pumps.
2. Mechanical seals eliminate the problem of excessive \_\_\_\_\_ leakage, which causes failure of pump and motor bearings and motor windings.
3. Mechanical seals are ideal for pumps that operate in \_\_\_\_\_. They not only conserve the fluid being pumped, but also improve system operation.
4. Most water service pumps use a carbon material for one of the \_\_\_\_\_ and ceramic (tungsten carbide) for the other. When the seals wear out, they are simply replaced.
5. You should replace a \_\_\_\_\_ whenever the seal is removed from the shaft for any reason, or whenever leakage causes undesirable effects on equipment or surrounding spaces.
6. \_\_\_\_\_ a new seal on the sealing face because body acid and grease or dirt will cause the seal to pit prematurely and leak.
7. Mechanical shaft seals are positioned on the shaft by stub or step sleeves. Mechanical shaft seals must not be positioned by \_\_\_\_\_.
8. \_\_\_\_\_ are chamfered (beveled) on outboard ends for easy mechanical seal mounting.
9. Mechanical shaft seals serve to ensure that \_\_\_\_\_ is supplied to the seal faces under all conditions of operation. They also ensure adequate circulation of the liquid at the seal faces to minimize the deposit of foreign matter on the seal parts.
10. If the packing is allowed to dry out, it will score \_\_\_\_\_.
11. When operating a centrifugal pump, be sure there is always a slight trickle of water coming out of the \_\_\_\_\_.
12. How often the \_\_\_\_\_ in a centrifugal pump should be renewed depends on several factors, such as the type of pump, condition of the shaft sleeve, and hours in use.

13. To ensure the longest possible service from pump packing, make certain the shaft or sleeve is smooth when the packing is removed from\_\_\_\_\_.

14. Rapid wear of the packing will be caused by \_\_\_\_\_(or shaft where no sleeve is installed).

15. When replacing packing, be sure the packing fits uniformly around\_\_\_\_\_.

**Answers:** 1. Mechanical seals, 2. Stuffing box, 3. Closed systems, 4. Seal faces, 5. Mechanical seal, 6. Do not touch, 7. Setscrews, 8. Shaft sleeves, 9. Liquid pressure, 10. The shaft, 11. Stuffing box or seal, 12. Packing, 13. A gland, 14. Roughness of the shaft sleeve, 15. The stuffing box

## Chapter 9 – HYDROGEN SULFIDE SECTION

**Section Focus:** You will learn the basics of hydrogen sulfide gas. At the end of this section, you the student will be able to understand and describe the dangers of hydrogen sulfide gas. There is a post quiz at the end of this section to review your comprehension and a final examination in the Assignment for your contact hours.

**Scope/Background:** Hydrogen sulfide ( $H_2S$ ) is a colorless gas with a strong odor of rotten eggs. Exposure to hydrogen sulfide may cause irritation to the eyes and respiratory system. It can also cause apnea, coma, convulsions; dizziness, headache, weakness, irritability, insomnia; stomach upset, and if liquid: frostbite. Workers may be harmed from exposure to hydrogen sulfide. The level of exposure depends upon the dose, duration, and work being done.

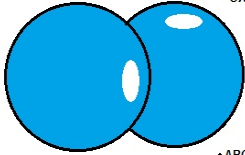
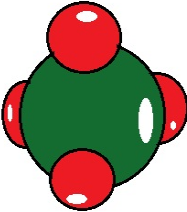
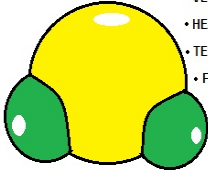
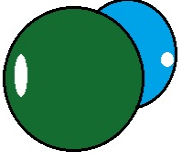
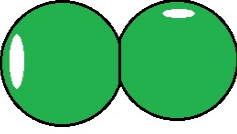
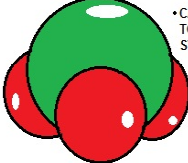
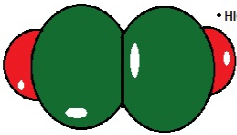
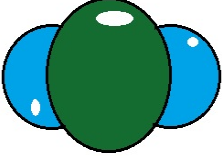
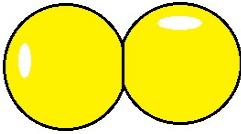
<b>OXYGEN</b> $O_2$  <ul style="list-style-type: none"> <li>• BELOW 19.5% IS OXYGEN DEPLETED</li> <li>• ABOVE 23.5% IS OXYGEN ENRICHED</li> </ul>	<b>METHANE</b> $CH_4$  <ul style="list-style-type: none"> <li>• AN ASPHIXIANT</li> <li>OXYGEN LEVELS SHOULD BE KEPT ABOVE 19.5%</li> </ul>	<b>HYDROGEN SULFIDE</b> $H_2S$  <ul style="list-style-type: none"> <li>• VERY HAZARDOUS</li> <li>• HEAVIER THAN AIR</li> <li>• TENDS TO POOL</li> <li>• FLAMMABLE</li> </ul> LEL OF 4%
<b>CARBON MONOXIDE</b> $CO$  <ul style="list-style-type: none"> <li>• AN ASPHIXIANT</li> </ul> PERMISSIBLE EXPOSURE LIMIT (PEL) IS 50ppm OVER AN 8-HOUR TWA	<b>NITROGEN</b> $N_2$  <ul style="list-style-type: none"> <li>• AN ASPHIXIANT</li> </ul> USED AS AN INERTING AGENT REPLACING OXYGEN IN THE AIR	<b>AMMONIA</b> $NH_3$  <ul style="list-style-type: none"> <li>• CAUSES DAMAGE TO RESPIRATORY SYSTEM, EYES, SKIN</li> </ul> 50ppm PEL 8-HOUR TWA
<b>ACETYLENE</b> $C_2H_2$  <ul style="list-style-type: none"> <li>• LIGHTER THAN AIR</li> <li>• HIGHLY FLAMMABLE</li> <li>• USED FOR WELDING</li> </ul> LEL OF 2.5%	<b>CARBON DIOXIDE</b> $CO_2$  <ul style="list-style-type: none"> <li>• AN ASPHIXIANT</li> </ul> PEL IS 5000ppm OVER 8-HOUR TWA	<b>CHLORINE</b> $Cl_2$ 

### COMMON GASES THAT CAN BE FOUND IN CONFINED SPACE

The health effects of hydrogen sulfide depend on how much  $H_2S$  a worker breathes and for how long. However, many effects are seen even at low concentrations. Effects range from mild, headaches or eye irritation, to very serious, unconsciousness and death.

<b>COMMON HAZARDOUS GASES THAT MAY BE PRESENT IN CONFINED SPACE</b>					
<b>SUBSTANCE *</b>	<b>8-HOUR TIME-WEIGHTED AVERAGE (TWA)</b>	<b>15-MINUTE SHORT-TERM EXPOSURE LIMIT (STEL)</b>	<b>CEILING LIMIT (Never To Be Exceeded)</b>	<b>IMMEDIATELY DANGEROUS TO LIFE AND HEALTH (IDLH)</b>	<b>RECOMMENDED ALARM SETTINGS (Low / High)</b>
AMMONIA	25 ppm	35 ppm	—	300 ppm	13 ppm / 25 ppm
CARBON MONOXIDE	25 ppm	100 ppm	—	1200 ppm	13 ppm / 25 ppm
CHLORINE	0.5 ppm	1 ppm	—	10 ppm	0.25 ppm / 0.5 ppm
HYDROGEN SULFIDE	—	—	10 ppm	100 ppm	5 ppm / 10 ppm
METHANE	1000 ppm	—	—	—	500 ppm / 1000 ppm
NITROGEN DIOXIDE	—	—	1 ppm	20 ppm	0.5 ppm / 1 ppm
SULFUR DIOXIDE	2 ppm	5 ppm	—	100 ppm	1 ppm / 2 ppm
OXYGEN	—	—	—	—	20.5 % of Atmosphere
LOWER EXPLOSIVE LIMIT (LEL)	—	—	—	—	5 % LEL

**EXAMPLE OF A CHART OF CONFINED SPACE GASES**



## Hydrogen Sulfide Gas

This section provides answers to basic questions about hydrogen sulfide gas. It will explain what hydrogen sulfide gas is, where it is found, how it can affect your health, and what you can do to prevent or reduce exposure to it. Hydrogen sulfide gas is also known as “sewer gas” because it is often produced by the decay of waste material. Hydrogen sulfide gas has a strong odor at low levels. At higher levels, your nose can become overwhelmed by the gas and you cannot smell it. At these higher levels, hydrogen sulfide gas can make you sick and even kill you.

### Hydrogen Sulfide Gas

#### **If you wait for a warning, it may be too late**

Hydrogen sulfide is a powerful and deadly gas which smells like rotten eggs at low concentrations and has a sweet smell at high concentrations. But workers should not rely on the smell as a warning. At high concentrations H<sub>2</sub>S may overcome one's sense of smell. The result could be instant death. Long exposure to low concentrations will also deaden the sense of smell.

#### **What it is**

H<sub>2</sub>S is explosive - it will ignite and explode when subjected to a spark or an ordinary flame - in any concentration from 4% to 44% of the air. It is also soluble in water and oil, so it may flow for a considerable distance from its origin before escaping above ground or in an entirely unexpected place. Because the vapor (gas) is heavier than air, it may travel for a long way until ignited and then flash back towards the source. Hydrogen sulfide is found in large amounts in the wastewater collection system.

#### **H<sub>2</sub>S Sources**

H<sub>2</sub>S is easily found widely in our industry and a good manager will warn operators of its dangers or of their exposure. It is formed by the decomposition of organic materials, so it is found in sewers and cesspools.

#### **Health Effects of H<sub>2</sub>S Acute Exposure**

Most importantly, H<sub>2</sub>S will kill you. The extent of acute poisoning danger depends on the concentration of H<sub>2</sub>S in the atmosphere. When you breathe in H<sub>2</sub>S, it goes directly through your lungs and into your bloodstream. To protect itself, your body "oxidizes" (breaks down) the H<sub>2</sub>S as rapidly as possible into a harmless compound. If you breathe in so much H<sub>2</sub>S that your body can't oxidize all of it, the H<sub>2</sub>S builds up in the blood and you become poisoned. The nervous centers in your brain which control breathing are paralyzed.

Your lungs stop working and you asphyxiate--just as though someone had come up and put their hands around your neck and strangled you. A worker can be overcome by H<sub>2</sub>S and lose consciousness in a few seconds. If he is luckily rescued in time and is given artificial respiration within a few minutes, the worker may recover.

This is acute poisoning. It can occur with no warning at all, since even the sense of smell may be overcome, and it can be fatal within a few seconds. Although acute poisoning is deadly if it is not caught in time, when caught and treated it is reversible; this is why rescue attempts with proper safety equipment are so important. Recent evidence has shown irreversible brain damage from acute high doses.

## Chronic Effects

H<sub>2</sub>S can also cause a wide range of sub-acute and chronic effects. At very low concentrations of 10-100 ppm, headache, dizziness, nausea and vomiting may develop, together with irritation of the eyes and respiratory tract (the lungs and trachea and bronchi, or air pipes from the nose and mouth to the lungs). The eyes become red, sore, inflamed, and sensitive to light. Respiratory system effects include cough, pain in the nose and throat, and painful breathing.

If exposure at low levels continues, the worker may develop a state of chronic poisoning. In addition to eye and respiratory tract irritation, there will be a slowed pulse rate, fatigue, insomnia, digestive disturbances, and cold sweats. More dangerous, if exposure at the level of 100 ppm (which results in eye and respiratory tract irritation and drowsiness after 15 minutes) lasts for several hours, it may result in death within the next 48 hours. Symptoms of chronic exposures at low levels are conjunctivitis (eye infections), headache, and attack of dizziness, diarrhea, and loss of weight. Chronic hydrogen sulfide intoxication is marked by headaches, eye disorders, chronic bronchitis, and a grey-green line on the gums. Reports of nervous system disorders including paralysis, meningitis, and neurological problems have been reported, but not confirmed. A study of workers and community residents of a California Wastewater Treatment facility forum complained of headaches, nausea, vomiting, depression, personality changes, nosebleeds and breathing difficulties. When compared to a non-exposed group of people, the exposed people showed abnormalities of color discrimination, hand-eye coordination, balance, and mood disturbances. In rats, exposure to hydrogen sulfide has caused teratogenic effects.

## How Much is Safe?

The OSHA Permissible Exposure Limit (PEL) for a ceiling concentration is 20 ppm hydrogen sulfide, a level which may not ever be exceeded. The acceptable maximum peak, for 10 minutes only, once during an 8 hour day if there is no other measurable exposure, is 50 ppm.

There is no time-weighted average because H<sub>2</sub>S is so fast-acting that no fluctuations above 20 ppm are safe; only one peak per day is allowed. This level is too high and recent recommendations are that it be lowered to 10 ppm. You should remember, however, that H<sub>2</sub>S is an invisible gas, floating freely and unpredictably, and a reading even below a 10 ppm Permissible Exposure Limit (PEL) may not guarantee your safety. There are no particular medical exams for exposure to H<sub>2</sub>S.



## Work Practices and Emergency Procedures

Whenever you enter a confined space such as a tank, make sure that you follow strict work practices, including a permit system. Make sure that the Confined Space Entry Standard 1910.146 is followed, that the air is continually monitored for the presence of H<sub>2</sub>S, and that an attendant be stationed outside a confined space. Both of you should wear supplied air and lifelines and rescue equipment must be immediately available.

- **If you work with H<sub>2</sub>S make sure that...**
  - Your employer has trained you in the hazards of H<sub>2</sub>S.
  - Your employer has appropriate rescue equipment onsite.

## Hazard Information Bulletin

*Following are excerpts from a Hazard Bulletin issued by OSHA after a fatality due to H<sub>2</sub>S exposure.*

Fundamentally, employers and employees must be alert to the fact that working with a "closed system" does not always ensure safety. Operations involving the opening of valves or pumps on otherwise closed systems, or working on such equipment that is not isolated or locked out, are particular sources of danger. When a normally closed system is opened, the potential exists for releasing hazardous chemicals into the workers' breathing zones in unknown concentrations.

**Respiratory Protection** -- Respirators must be provided by the employer when effective engineering controls are not feasible, or while they are being instituted, when such equipment is necessary to protect the health of the worker. The employer must provide respirators that are applicable for the purpose intended. Written procedures must be developed for the safe use of respirators during the performance of operations presenting a potential exposure to hazardous chemicals. Under circumstances where individuals may be exposed to an unknown concentration of hydrogen sulfide or some other hazardous chemical, back-up personnel with appropriate respirators and emergency equipment must be present.



You must be careful around sewer mains and always be careful of Hydrogen Sulfide and Carbon Monoxide gases. Never try to enter a confined space to rescue a downed employee unless you have been trained in rescue procedures and have called 911 first.

## Hydrogen Sulfide Highlights

Hydrogen sulfide or H<sub>2</sub>S problems are very common in the collection and wastewater system. There are many chemicals used to help or treat this problem. Salts of zinc, lime, hydrogen peroxide, chlorine and magnesium hydroxide are used in the treatment of hydrogen sulfide problems.

Hydrogen sulfide production in collection systems can cause a number of problems, including the following: Corrosion of the pipes and manholes, creation of hazardous atmospheres and foul odors.

The best method of controlling hydrogen sulfide is to eliminate its habitat or growth area by keeping sewers cleaner, this will harbor fewer slime bacteria.

Statements regarding the reduction of hydrogen sulfide: Salts of zinc and iron may precipitate sulfides, lime treatments can also kill bacteria that produces hydrogen sulfide, but this creates a sludge disposal problem. Chlorination is effective at reducing the bacteria which produce hydrogen sulfide.

Hydrogen sulfide conditions occur in the sewer system because of the lack of oxygen.

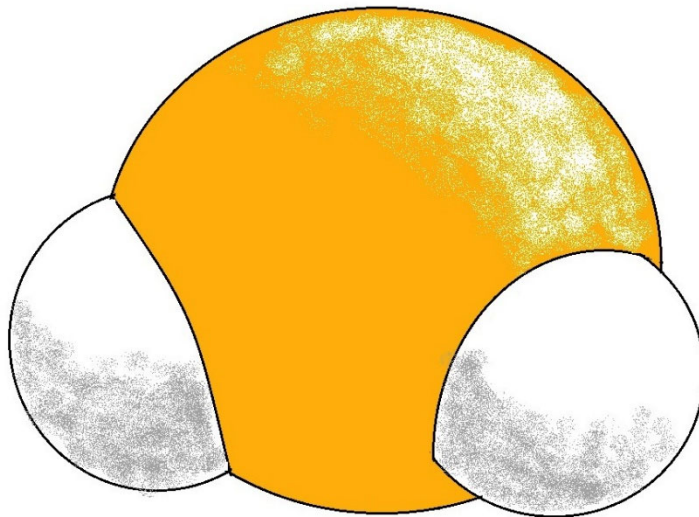

## Hydrogen Sulfide Post-Quiz

1. At very low H<sub>2</sub>S concentrations of \_\_\_\_\_ ppm, headache, dizziness, nausea and vomiting may develop, together with irritation of the eyes and respiratory tract.
2. At very \_\_\_\_\_ H<sub>2</sub>S concentrations, respiratory system effects include cough, pain in the nose and throat, and painful breathing.
3. More dangerous, if exposure at the level of 100 ppm (which results in eye and respiratory tract irritation and drowsiness after 15 minutes) lasts for several hours, it may result in death within the next \_\_\_\_\_ hours.

### How Much is Safe?

4. The OSHA Permissible Exposure Limit (PEL) for a ceiling concentration is \_\_\_\_\_ ppm hydrogen sulfide, a level which may not ever be exceeded.
5. The acceptable maximum peak, for 10 minutes only, once during an \_\_\_\_\_ hour day if there is no other measurable exposure, is 50 ppm.
6. There is no time-weighted average because H<sub>2</sub>S is so fast-acting that no fluctuations above \_\_\_\_\_ ppm are safe; only one peak per day is allowed. This level is too high and recent recommendations are that it be lowered to 10 ppm.
7. You should remember, however, that H<sub>2</sub>S is an invisible gas, floating freely and unpredictably, and a reading even below a \_\_\_\_\_ ppm Permissible Exposure Limit (PEL) may not guarantee your safety. There are no particular medical exams for exposure to H<sub>2</sub>S.

### Work Practices and Emergency Procedures

8. Whenever you enter a confined space such as a tank, make sure that you follow work recommendations, including some type of permit system. True or False
9. Make sure that the Confined Space Entry Standard 1910.146 is followed, that the air is continually monitored for the presence of H<sub>2</sub>S, and that an attendant be stationed outside a confined space. Both of you should wear supplied air and lifelines and rescue equipment must be immediately available. True or False

10. Respirators must be provided by the employer when effective engineering controls are not feasible, or while they are being instituted, when such equipment is necessary to protect the health of the worker. True or False

**Answers**

1. 10-100, 2. Low, 3. 48, 4. 20, 5. 8, 6. 20, 7. 10, 8. False, 9. True, 10. True

# Chapter 10- CONFINED SPACE SECTION

**Section Focus:** You will learn the basics of proper confined space entry. At the end of this section, you the student will be able to understand and describe confined space and permit required confined spaces. There is a post quiz at the end of this section to review your comprehension and a final examination in the Assignment for your contact hours.

**Scope/Background:** The Confined Space Entry Program is provided to protect authorized employees that will enter confined spaces and may be exposed to hazardous atmospheres, engulfment in materials, conditions which may trap or asphyxiate due to converging or sloping walls, or contains any other safety or health hazards.

**Reference:** OSHA-Permit-Required Confined Spaces (29 CFR 1910.146).

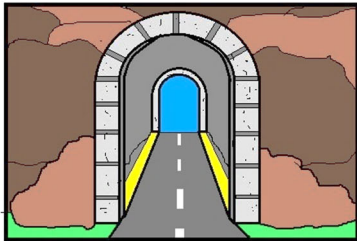

TUNNELS

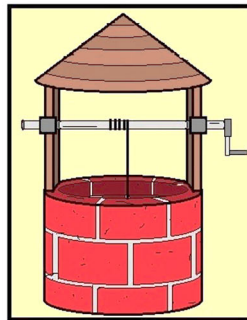

WELLS



MANHOLES

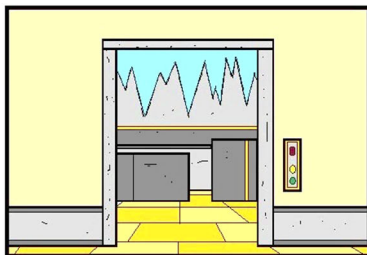

COLD STORAGE

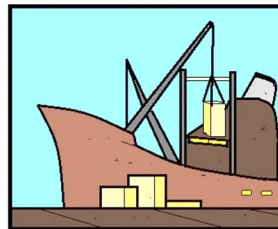

SHIP HOLDS

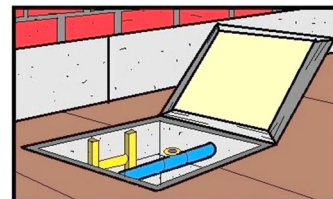

SUB-CELLARS

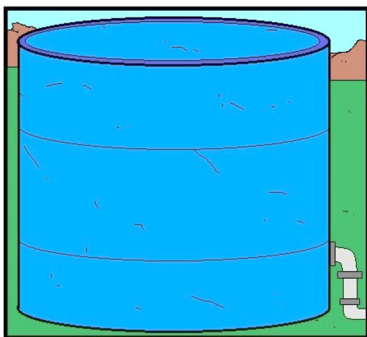

STORAGE TANKS

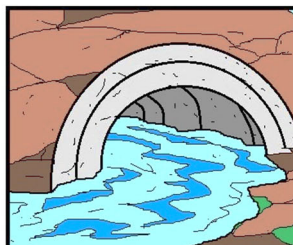

CULVERTS

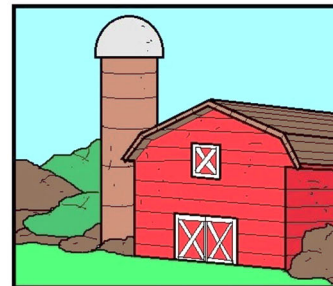

SILOS

## EXAMPLES OF CONFINED SPACES



**Scenario.** A fixed ladder drops deep inside a permit required or type II confined space. One man goes inside and passes out from hazardous fumes. A second man goes in and dies within seconds trying to help his buddy.

A third man goes in to save the others and dies on the spot. Only the first man survives, that is if you can say that being brain dead is surviving. Never try to rescue your buddies unless you are trained and have proper equipment. Never! Call 911 first. This scenario actually happened inside a sewer system. ***Don't be the next victim.***



## Confined Spaces are...

- large enough to allow entry of any body part, and
- limited or restricted entry or exit, and
- not designed for continuous employee occupancy

### **Permit Required Confined Spaces are confined spaces that have any of the following**

- potential hazardous atmosphere
- material inside that may engulf or trap you
- internal design that could trap or asphyxiate you
- any other serious safety or health hazard

### ***Entry Permits are required before you enter any "Permit Required Confined Space"***

#### **Hazards include**

- Fire & Explosion
- Engulfment
- Asphyxiation
- Entrapment
- Slips & Falls
- Electric Shock
- Noise & Vibration
- Chemical Exposure
- Toxic Atmospheres
- Thermal / Chemical Burns

#### **Engineering Controls**

- Ventilation
- Locked Access
- Lighting

#### **Administrative Controls**

- Controlled Access
- Hazard Assessments
- Entry Permits & Procedures
- Signs & Lockout Tagout
- Training

## Smart Safety Rules

Know what you are getting into.

Know how to get out in an emergency.

Know the hazards & how they are controlled.

Only authorized & trained personnel may enter a Confined Space or act as an attendant.

No smoking in Confined Space or near entrance or exit area.

Attendant must be present at all times.

Constant visual or voice communication must be maintained between the attendant and entrants.

No bottom or side entry will be made, or work conducted below the level any hanging material or material which could cause engulfment.

Air and oxygen monitoring is required before entering a Permit-Required Confined Space.

Ventilation & oxygen monitoring is required when welding is performed.

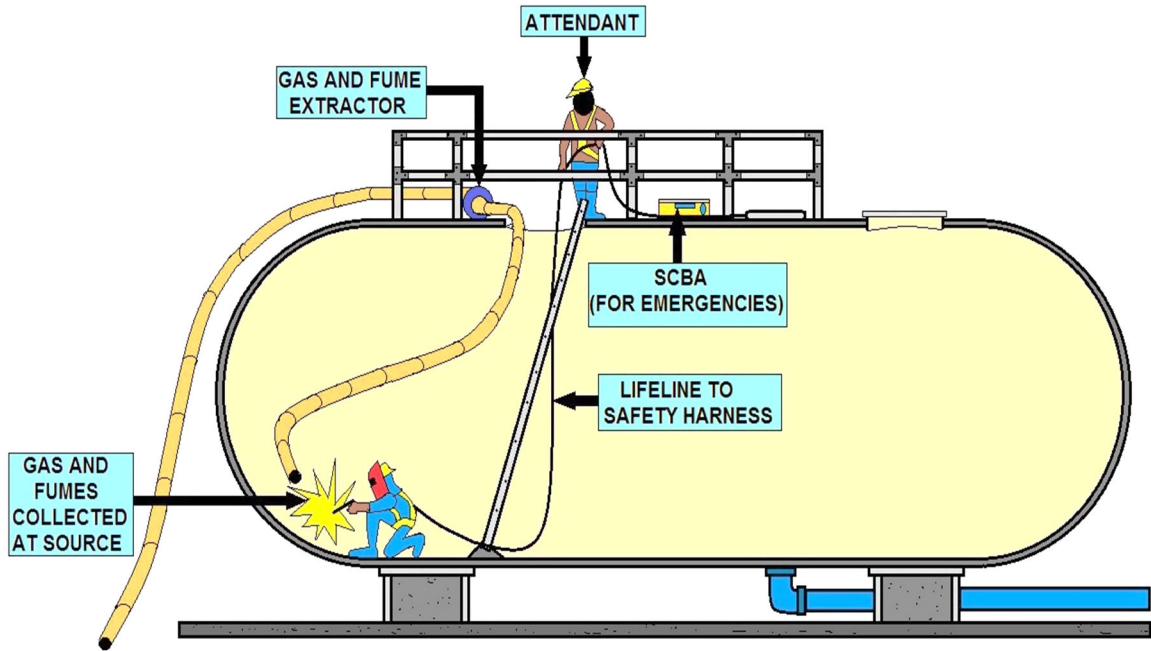

**CONFINED SPACE DIAGRAM**

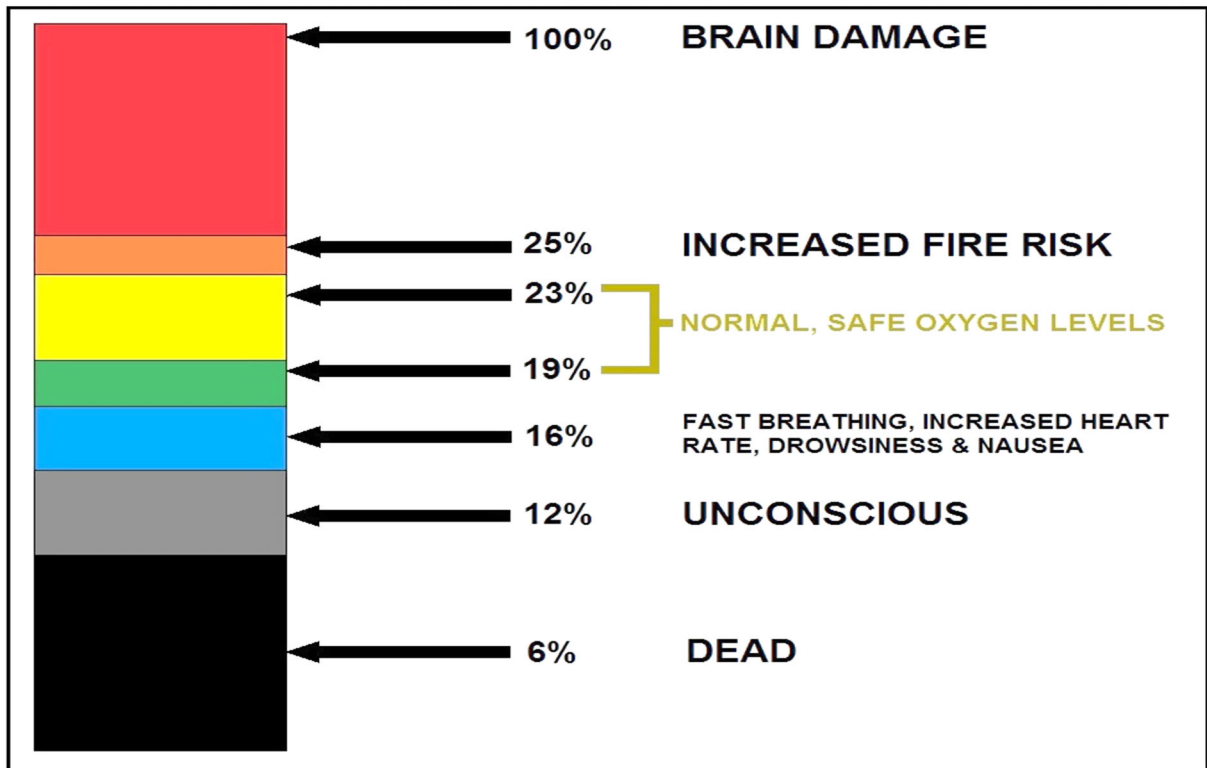

**RESULTS OF OXYGEN LEVELS IN CONFINED SPACES**

## Confined Space Terms

"Acceptable entry conditions" means the conditions that must exist in a permit space to allow entry and to ensure that employees involved with a permit-required confined space entry can safely enter into and work within the space.

"Attendant" means an individual stationed outside one or more permit spaces who monitors the authorized entrants and who performs all attendant's duties assigned in the employer's permit space program.

"Authorized entrant" means an employee who is authorized by the employer to enter a permit space.

"Blanking or blinding" means the absolute closure of a pipe, line, or duct by the fastening of a solid plate (such as a spectacle blind or a skillet blind) that completely covers the bore and that is capable of withstanding the maximum pressure of the pipe, line, or duct with no leakage beyond the plate.

"Confined space" means a space that:

(1) Is large enough and so configured that an employee can bodily enter and perform assigned work; and

(2) Has limited or restricted means for entry or exit (for example, tanks, vessels, silos, storage bins, hoppers, vaults, and pits are spaces that may have limited means of entry.); and

(3) Is not designed for continuous employee occupancy.

"Double block and bleed" means the closure of a line, duct, or pipe by closing and locking or tagging two in-line valves and by opening and locking or tagging a drain or vent valve in the line between the two closed valves.

"Emergency" means any occurrence (including any failure of hazard control or monitoring equipment) or event internal or external to the permit space that could endanger entrants.

"Engulfment" means the surrounding and effective capture of a person by a liquid or finely divided (flowable) solid substance that can be aspirated to cause death by filling or plugging the respiratory system or that can exert enough force on the body to cause death by strangulation, constriction, or crushing.

"Entry" means the action by which a person passes through an opening into a permit-required confined space. Entry includes ensuing work activities in that space and is considered to have occurred as soon as any part of the entrant's body breaks the plane of an opening into the space.

"Entry permit (permit)" means the written or printed document that is provided by the employer to allow and control entry into a permit space and that contains the information specified in paragraph (f) of this section.

"Entry supervisor" means the person (such as the employer, foreman, or crew chief) responsible for determining if acceptable entry conditions are present at a permit space where entry is planned, for authorizing entry and overseeing entry operations, and for terminating entry as required by this section.

NOTE: An entry supervisor also may serve as an attendant or as an authorized entrant, as long as that person is trained and equipped as required by this section for each role he or she fills. Also, the duties of entry supervisor may be passed from one individual to another during the course of an entry operation.

"Hazardous atmosphere" means an atmosphere that may expose employees to the risk of death, incapacitation, impairment of ability to self-rescue (that is, escape unaided from a permit space), injury, or acute illness from one or more of the following causes:

- (1) Flammable gas, vapor, or mist in excess of 10 percent of its lower flammable limit (LFL);
- (2) Airborne combustible dust at a concentration that meets or exceeds its LFL;

NOTE: This concentration may be approximated as a condition in which the dust obscures vision at a distance of 5 feet (1.52 m) or less.

- (3) Atmospheric oxygen concentration below 19.5 percent or above 23.5 percent;
- (4) Atmospheric concentration of any substance for which a dose or a permissible exposure limit is published in Subpart G, Occupational Health and Environmental Control, or in Subpart Z, Toxic and Hazardous Substances, of this Part and which could result in employee exposure in excess of its dose or permissible exposure limit;

NOTE: An atmospheric concentration of any substance that is not capable of causing death, incapacitation, impairment of ability to self-rescue, injury, or acute illness due to its health effects is not covered by this provision.

- (5) Any other atmospheric condition that is immediately dangerous to life or health.

NOTE: For air contaminants for which OSHA has not determined a dose or permissible exposure limit, other sources of information, such as Material Safety Data Sheets that comply with the Hazard Communication Standard, section 1910.1200 of this Part, published information, and internal documents can provide guidance in establishing acceptable atmospheric conditions.

"Hot work permit" means the employer's written authorization to perform operations (for example, riveting, welding, cutting, burning, and heating) capable of providing a source of ignition.

"Immediately dangerous to life or health (IDLH)" means any condition that poses an immediate or delayed threat to life or that would cause irreversible adverse health effects or that would interfere with an individual's ability to escape unaided from a permit space.

NOTE: Some materials -- hydrogen fluoride gas and cadmium vapor, for example -- may produce immediate transient effects that, even if severe, may pass without medical attention, but are followed by sudden, possibly fatal collapse 12-72 hours after exposure. The victim "feels normal" from recovery from transient effects until collapse. Such materials in hazardous quantities are considered to be "immediately" dangerous to life or health.

"Inerting" means the displacement of the atmosphere in a permit space by a noncombustible gas (such as nitrogen) to such an extent that the resulting atmosphere is noncombustible.

NOTE: This procedure produces an IDLH oxygen-deficient atmosphere.

"Isolation" means the process by which a permit space is removed from service and completely protected against the release of energy and material into the space by such means as: blanking or blinding; misaligning or removing sections of lines, pipes, or ducts; a double block and bleed system; lockout or tagout of all sources of energy; or blocking or disconnecting all mechanical linkages.

"Line breaking" means the intentional opening of a pipe, line, or duct that is or has been carrying flammable, corrosive, or toxic material, an inert gas, or any fluid at a volume, pressure, or temperature capable of causing injury.

"Non-permit confined space" means a confined space that does not contain or, with respect to atmospheric hazards, have the potential to contain any hazard capable of causing death or serious physical harm.

"Oxygen deficient atmosphere" means an atmosphere containing less than 19.5 percent oxygen by volume.

"Oxygen enriched atmosphere" means an atmosphere containing more than 23.5 percent oxygen by volume.

"Permit-required confined space (permit space)" means a confined space that has one or more of the following characteristics:

- (1) Contains or has a potential to contain a hazardous atmosphere;
- (2) Contains a material that has the potential for engulfing an entrant;
- (3) Has an internal configuration such that an entrant could be trapped or asphyxiated by inwardly converging walls or by a floor which slopes downward and tapers to a smaller cross-section; or
- (4) Contains any other recognized serious safety or health hazard.

"Permit-required confined space program (permit space program)" means the employer's overall program for controlling, and, where appropriate, for protecting employees from, permit space hazards and for regulating employee entry into permit spaces.

"Permit system" means the employer's written procedure for preparing and issuing permits for entry and for returning the permit space to service following termination of entry.

"Prohibited condition" means any condition in a permit space that is not allowed by the permit during the period when entry is authorized.

"Rescue service" means the personnel designated to rescue employees from permit spaces.

"Retrieval system" means the equipment (including a retrieval line, chest or full-body harness, wristlets, if appropriate, and a lifting device or anchor) used for non-entry rescue of persons from permit spaces.

"Testing" means the process by which the hazards that may confront entrants of a permit space are identified and evaluated. Testing includes specifying the tests that are to be performed in the permit space.



Would you consider this a confined space? How about a permit required?  
Think about the various chemicals that we use inside confined spaces.

## **New Confined Space Construction Standard**

On May 4, 2015, OSHA issued a new standard for construction work in confined spaces, which became effective August 3, 2015. Confined spaces can present physical and atmospheric hazards that can be avoided if they are recognized and addressed prior to entering these spaces to perform work. The new standard, Subpart AA of 29 CFR 1926 will help prevent construction workers from being hurt or killed by eliminating and isolating hazards in confined spaces at construction sites similar to the way workers in other industries are already protected.

The new standard, Subpart AA of 29 CFR 1926, will help prevent construction workers from being hurt or killed by eliminating and isolating hazards in confined spaces at construction sites similar to the way workers in other industries are already protected.

### **Training requirements**

Employers must provide training to each employee whose work is regulated by this standard, at no cost to the employee, and ensure that employees possess the understanding, knowledge and skills necessary to safely perform the duties assigned under this standard. Training must result in an understanding of the hazards in the permit space and the methods used to isolate, control or in other ways protect employees from these hazards. For employees not authorized to perform entry rescues, it must convey the dangers of attempting such rescues.

### **Affected employees must be trained:**

- In both a language and vocabulary that the employee can understand;
- Before the employee is first assigned duties under this standard;
- Before there is a change in assigned duties;
- Whenever there is a change in permit space entry operations that presents a hazard about which an employee has not previously been trained; and
- Whenever there is any evidence of a deviation from the permit space entry procedures required by paragraph §1926.1204(c) of this standard or there are inadequacies in the employee's knowledge or use of these procedures.

The training must establish employee proficiency in the duties required by this standard and must introduce new or revised procedures, as necessary, for compliance.

The employer must maintain training records to show required training has taken place. Training records must contain each employee's name, the name of the trainers, and the dates of training. Documentation must be available for inspection by employees and their authorized representatives, for the period of time the worker is employed by that employer.

### **Common questions**

To assist employers in complying with the new standard, here are some frequently asked questions and answers outline by on its website at [www.osha.gov](http://www.osha.gov):

### **How do I know whether to follow the general industry or construction confined space rule?**

If you are doing construction work – such as building a new structure or upgrading an old one – then you must follow the construction confined space rule.

**Why did OSHA believe that the former standard needed to be changed?**

Previously the only requirement for confined spaces in construction was training. OSHA concluded this was inadequate as injuries and fatalities continued to occur.

**How does the new final rule differ from the rules that previously applied to construction work performed in confined spaces?**

The rule requires employers to determine what kinds of spaces their workers are in, what hazards could be there, how those hazards should be made safe, what training workers should receive, and how to rescue those workers if anything goes wrong.

**Where can I find the final rule for Confined Spaces in Construction?**

Information on the new confined spaces standard can be found on the Confined Spaces page at [www.osha.gov/confinedspaces/index.html](http://www.osha.gov/confinedspaces/index.html).

**How can I contact OSHA if I have questions about the final rule?**

For compliance assistance regarding application of the final rule contact: Directorate of Construction, Room N3468, OSHA, U.S. Department of Labor, 200 Constitution Avenue NW, Washington, DC 20210; telephone (202)-693-2020 or fax (202)-693-1689.

**Who is affected by Subpart AA?**

All construction employers whose workers may be exposed to confined space hazards.

**Do I need to do anything if there are permit spaces at the worksite, but my employees will not need to enter the permit space?**

Yes, you must take effective steps to prevent your employees from entering the space.

**What standard should I follow if my workers are doing construction AND general industry work in confined spaces?**

An employer whose workers are engaged in both construction and general industry work in confined spaces will meet OSHA requirements if that employer meets the requirements of 29 CFR 1926 Subpart AA - Confined Spaces in Construction.



# Confined Space Entry Program - Introduction

## Purpose

The Confined Space Entry Program is provided to protect authorized employees that will enter confined spaces and may be exposed to hazardous atmospheres, engulfment in materials, conditions which may trap or asphyxiate due to converging or sloping walls, or contains any other safety or health hazards.

**Reference:** OSHA-Permit-Required Confined Spaces (**29 CFR 1910.146**).

## Scope

You are required to recognize the dangers and hazards associated with confined spaces, and this program is designed to assist you in the safety of and compliance with the OSHA standards associated with such.

Most communities will utilize the Fire Department for all rescues and additional assistance dealing with confined spaces, understanding that most Fire Department operations utilize additional in house SOG's/SOP's pertaining to such operations.

## Definitions

### **Confined space:**

- ✓ Is large enough or so configured that an employee can bodily enter and perform work.
- ✓ Has limited or restricted means for entry or exit (i.e. tanks, vessels, silos, storage bins, hoppers, vaults, and pits are spaces that may have limited means of entry).
- ✓ Is not designed for continuous employee occupancy.
- ✓ Permit required confined space (permit space), is a confined space that has one or more of the following characteristics:
  1. Contains or has a potential to contain a hazardous atmosphere.
  2. Contains a material that has the potential for engulfing an entrant.
  3. Has an internal configuration such that an entrant could be trapped or asphyxiated by inwardly covering walls or by a floor which slopes downward and tapers to a smaller cross-section.
  4. Contains any other recognized serious safety or health hazard.

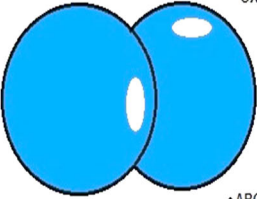
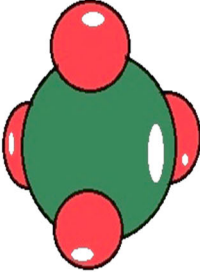
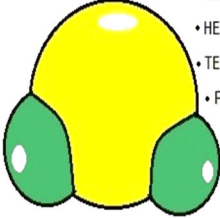
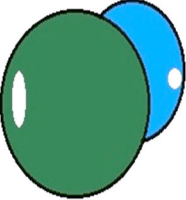
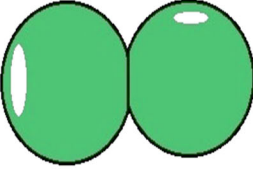
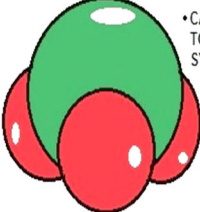
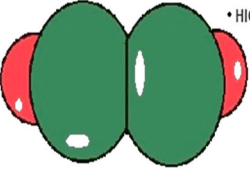
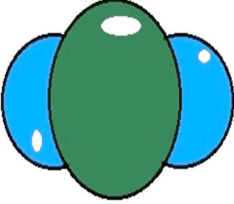
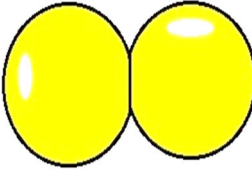

**Each Permit-Required Confined Space will be marked "*Confined Space - Entry Permit Required*".**  
***Most of this text is credited to OSHA.***

<p><b>OXYGEN</b> <math>O_2</math></p>	<p><b>METHANE</b> <math>CH_4</math></p>	<p><b>HYDROGEN SULFIDE</b> <math>H_2S</math></p>
 <ul style="list-style-type: none"> <li>• BELOW 19.5% IS OXYGEN DEPLETED</li> <li>• ABOVE 23.5% IS OXYGEN ENRICHED</li> </ul>	 <ul style="list-style-type: none"> <li>• AN ASPHIXIANT</li> </ul> <p>OXYGEN LEVELS SHOULD BE KEPT ABOVE 19.5%</p>	 <ul style="list-style-type: none"> <li>• VERY HAZARDOUS</li> <li>• HEAVIER THAN AIR</li> <li>• TENDS TO POOL</li> <li>• FLAMMABLE</li> </ul> <p>LEL OF 4%</p>
<p><b>CARBON MONOXIDE</b> <math>CO</math></p>	<p><b>NITROGEN</b> <math>N_2</math></p>	<p><b>AMMONIA</b> <math>NH_3</math></p>
 <ul style="list-style-type: none"> <li>• AN ASPHIXIANT</li> </ul> <p>PERMISSABLE EXPOSURE LIMIT (PEL) IS 50ppm OVER AN 8-HOUR TWA</p>	 <ul style="list-style-type: none"> <li>• AN ASPHIXIANT</li> </ul> <p>USED AS AN INERTING AGENT REPLACING OXYGEN IN THE AIR</p>	 <ul style="list-style-type: none"> <li>• CAUSES DAMAGE TO RESPIRATORY SYSTEM, EYES, SKIN</li> </ul> <p>50ppm PEL 8-HOUR TWA</p>
<p><b>ACETYLENE</b> <math>C_2H_2</math></p>	<p><b>CARBON DIOXIDE</b> <math>CO_2</math></p>	<p><b>CHLORINE</b> <math>Cl_2</math></p>
 <ul style="list-style-type: none"> <li>• LIGHTER THAN AIR</li> <li>• HIGHLY FLAMMABLE</li> <li>• USED FOR WELDING</li> </ul> <p>LEL OF 2.5%</p>	 <ul style="list-style-type: none"> <li>• AN ASPHIXIANT</li> </ul> <p>PEL IS 5000ppm OVER 8-HOUR TWA</p>	

## COMMON GASES THAT CAN BE FOUND IN CONFINED SPACE

## Confined Space Hazards

Fatalities and injuries constantly occur among construction workers who, during the course of their jobs, are required to enter confined spaces. In some circumstances, these workers are exposed to multiple hazards, any of which may cause bodily injury, illness, or death.

Newspaper and magazine articles abound with stories of workers injured and killed from a variety of atmospheric factors and physical agents. Throughout the construction jobsite, contractors and workers encounter both inherent and induced hazards within confined workspaces.

### Inherent Hazards

Inherent hazards, such as electrical, thermal, chemical, mechanical, etc., are associated with specific types of equipment and the interactions among them.

Examples include high voltage (shock or corona discharge and the resulting burns), radiation generated by equipment, defective design, omission of protective features (no provision for grounding non-current-carrying conductive parts), high or low temperatures, high noise levels, and high-pressure vessels and lines (rupturing with resultant release of fragments, fluids, gases, etc.).

Inherent hazards usually cannot be eliminated without degrading the system or equipment, or without making them inoperative. Therefore, emphasis must be placed on hazard control methods.

### Induced Hazards

Induced hazards arise, and are induced from, a multitude of incorrect decisions and actions that occur during the actual construction process. Some examples are: omission of protective features, physical arrangements that may cause unintentional worker contact with electrical energy sources, oxygen-deficient atmospheres created at the bottom of pits or shafts, lack of safety factors in structural strength, and flammable atmospheres.

### Typical Examples of Confined Workspaces

Following are typical examples of confined workspaces in construction which contain both inherent and induced hazards.

#### Vaults

A variety of vaults are found on the construction jobsite. On various occasions, workers must enter these vaults to perform a number of functions.

The restricted nature of vaults and their frequently below-grade location can create an assortment of safety and health problems.

#### Oxygen-Deficient Atmosphere

One of the major problems confronting construction workers while working in vaults is the ever-present possibility of an oxygen-deficient atmosphere.



### **Explosive or Toxic Gases, Vapors, or Fumes**

While working in an electrical vault, workers may be exposed to the build-up of explosive gases such as those used for heating (propane). Welding and soldering produce toxic fumes which are confined in the limited atmosphere.

### **Electrical Shock**

Electrical shock is often encountered from power tools, line cords, etc. In many instances, such electrical shock results from the fact that the contractor has not provided an approved grounding system or the protection afforded by ground-fault circuit interrupters or low-voltage systems.

### **Purging**

In some instances, purging agents such as nitrogen and argon may enter the vault from areas adjacent to it. These agents may displace the oxygen in the vault to the extent that it will asphyxiate workers almost immediately.

### **Materials Falling In and On**

A hazard normally considered a problem associated with confined spaces is material or equipment which may fall into the vault or onto workers as they enter and leave the vault.

Vibration could cause the materials on top of the vault to roll off and strike workers. If the manhole covers were removed, or if they were not installed in the first place, materials could fall into the vault, causing injury to the workers inside.

### **Condenser Pits**

A common confined space found in the construction of nuclear power plants is the condenser pit. Because of their large size, they are often overlooked as potentially hazardous confined spaces.

These below-grade areas create large containment areas for the accumulation of toxic fumes, gases, and so forth, or for the creation of oxygen-deficient atmospheres when purging with argon, Freon, and other inert gases.

Other hazards will be created by workers above dropping equipment, tools, and materials into the pit.

### **Manholes**

Throughout the construction site, manholes are commonplace. As means of entry into and exit from vaults, tanks, pits, and so forth, manholes perform a necessary function. However, these confined spaces may present serious hazards which could cause injuries and fatalities.

A variety of hazards are associated with manholes. To begin with, the manhole could be a dangerous trap into which the worker could fall. Often covers are removed and not replaced, or else they are not provided in the first place.

### **Pipe Assemblies**

One of the most frequently unrecognized types of confined spaces encountered throughout the construction site is the pipe assembly. Piping of sixteen to thirty-six inches in diameter is commonly used for a variety of purposes.

For any number of reasons, workers will enter the pipe. Once inside, they are faced with potential oxygen-deficient atmospheres, often caused by purging with argon or another inert gas. Welding fumes generated by the worker in the pipe, or by other workers operating outside the pipe at either end, subject the worker to toxic atmospheres.

The generally restricted dimensions of the pipe provide little room for the workers to move about and gain any degree of comfort while performing their tasks. Once inside the pipe, communication is extremely difficult. In situations where the pipe bends, communication and extrication become even more difficult. Electrical shock is another problem to which the worker is exposed.

Ungrounded tools and equipment or inadequate line cords are some of the causes. As well, heat within the pipe run may cause the worker to suffer heat prostration.

### **Ventilation Ducts**

Ventilation ducts, like pipe runs, are very common at the construction site. These sheet metal enclosures create a complex network which moves heated and cooled air and exhaust fumes to desired locations in the plant.

Ventilation ducts may require that workers enter them to cut out access holes, install essential parts of the duct, etc. Depending on where these ducts are located, oxygen deficiency could exist. They usually possess many bends, which create difficult entry and exit and which also make it difficult for workers inside the duct to communicate with those outside it. Electrical shock hazards and heat stress are other problems associated with work inside ventilation ducts.

### **Tanks**

Tanks are another type of confined workspace commonly found in construction. They are used for a variety of purposes, including the storage of water, chemicals, etc.

Tanks require entry for cleaning and repairs. Ventilation is always a problem. Oxygen-deficient atmospheres, along with toxic and explosive atmospheres created by the substances stored in the tanks, present hazards to workers. Heat, another problem in tanks, may cause heat prostration, particularly on a hot day.

Since electrical line cords are often taken into the tank, the hazard of electrical shock is always present. The nature of the tank's structure often dictates that workers must climb ladders to reach high places on the walls of the tank.

### **Sumps**

Sumps are commonplace. They are used as collection places for water and other liquids. Workers entering sumps may encounter an oxygen-deficient atmosphere.

Also, because of the wet nature of the sump, electrical shock hazards are present when power tools are used inside. Sumps are often poorly illuminated. Inadequate lighting may create an accident situation.

### **Containment Cavities**

These large below-grade areas are characterized by little or no air movement. Ventilation is always a problem. In addition, the possibility of oxygen deficiency exists. As well, welding and other gases may easily collect in these areas, creating toxic atmospheres. As these structures near completion, more confined spaces will exist as rooms are built off the existing structure.

### **Electrical Transformers**

Electrical transformers are located on the jobsite. They often contain a nitrogen purge or dry air. Before they are opened, they must be well vented by having air pumped in. Workers, particularly electricians and power plant operators, will enter these transformers through hatches on top for various work-related reasons. Testing for oxygen deficiency and for toxic atmospheres is mandatory.

### **Heat Sinks**

These larger pit areas hold cooling water in the event that there is a problem with the pumps located at the water supply to the plant--normally a river or lake--which would prevent cooling water from reaching the reactor core.

When in the pits, workers are exposed to welding fumes and electrical hazards, particularly because water accumulates in the bottom of the sink.

Generally, it is difficult to communicate with workers in the heat sink, because the rebar in the walls of the structure deaden radio signals.



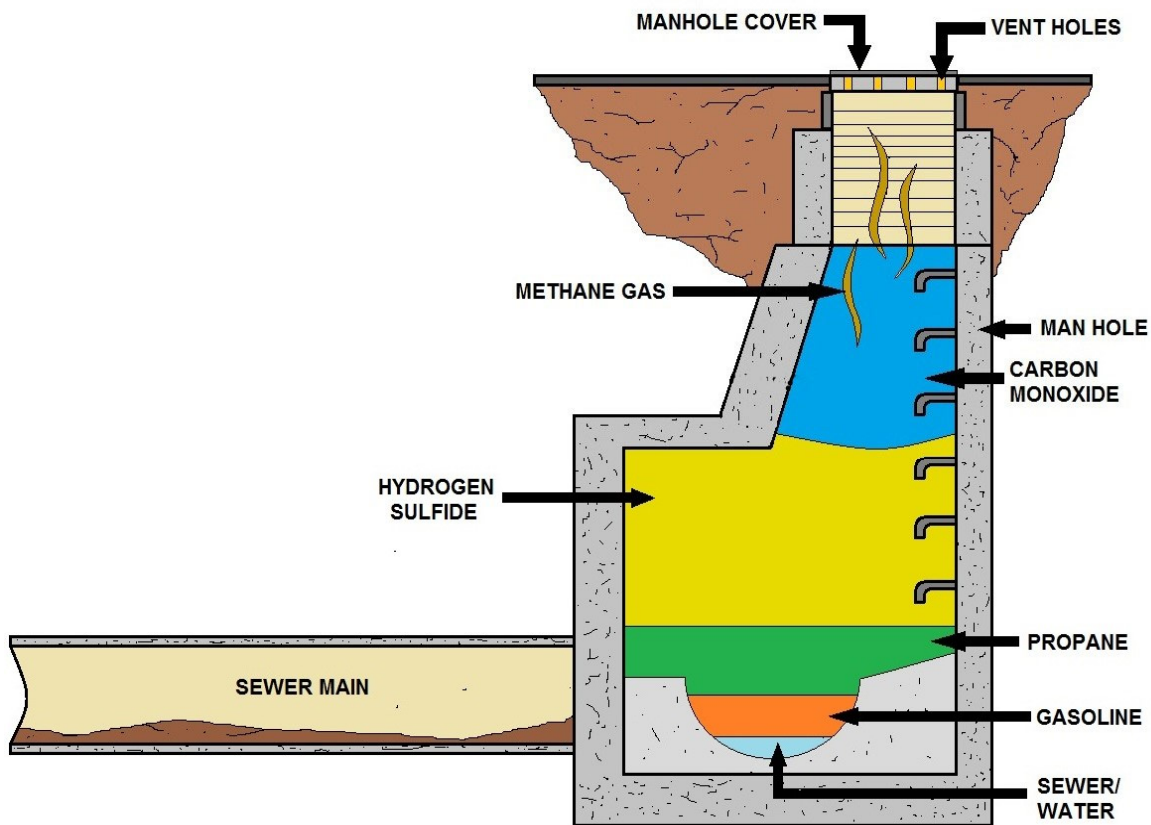

**POSSIBLE HAZARDOUS ATMOSPHERES PRESENT IN A CONFINED SPACE  
(EXAMPLE IS OF A SEWER MAIN)**

COMMON HAZARDOUS GASES THAT MAY BE PRESENT IN CONFINED SPACE					
SUBSTANCE *	8-HOUR TIME-WEIGHTED AVERAGE (TWA)	15-MINUTE SHORT-TERM EXPOSURE LIMIT (STEL)	CEILING LIMIT (Never To Be Exceeded)	IMMEDIATELY DANGEROUS TO LIFE AND HEALTH (IDLH)	RECOMMENDED ALARM SETTINGS (Low / High)
AMMONIA	25 ppm	35 ppm	—	300 ppm	13 ppm / 25 ppm
CARBON MONOXIDE	25 ppm	100 ppm	—	1200 ppm	13 ppm / 25 ppm
CHLORINE	0.5 ppm	1 ppm	—	10 ppm	0.25 ppm / 0.5 ppm
HYDROGEN SULFIDE	—	—	10 ppm	100 ppm	5 ppm / 10 ppm
METHANE	1000 ppm	—	—	—	500 ppm / 1000 ppm
NITROGEN DIOXIDE	—	—	1 ppm	20 ppm	0.5 ppm / 1 ppm
SULFUR DIOXIDE	2 ppm	5 ppm	—	100 ppm	1 ppm / 2 ppm
OXYGEN	—	—	—	—	20.5 % of Atmosphere
LOWER EXPLOSIVE LIMIT (LEL)	—	—	—	—	5 % LEL

**EXAMPLE OF A CHART OF CONFINED SPACE GASES**

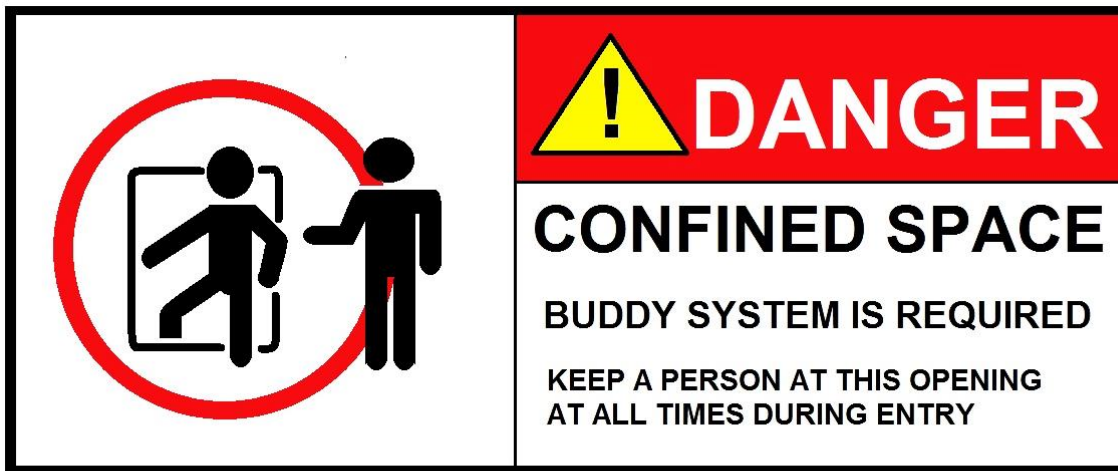

EXAMPLE OF A CONFINED SPACE ENTRY DANGER SIGN

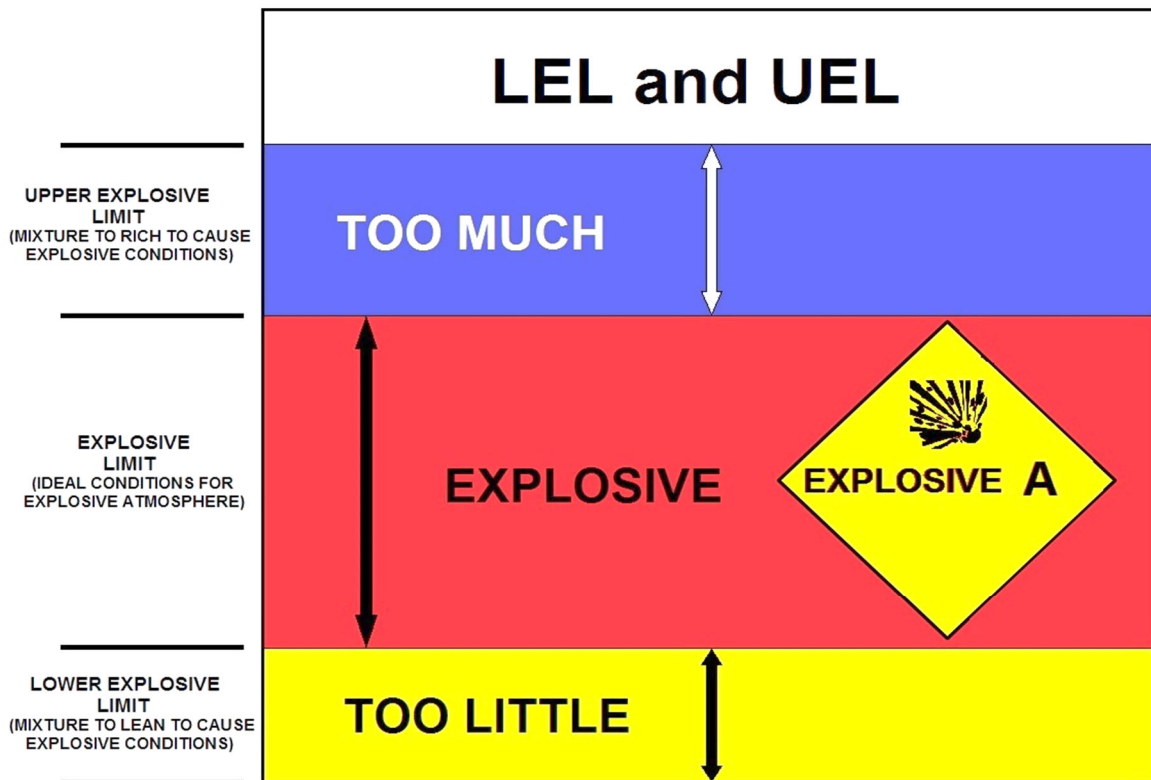

UNDERSTANDING UPPER (UEL) & LOWER (LEL) EXPLOSIVE LIMITS



## Unusual Conditions

### Confined Space within a Confined Space

By the very nature of construction, situations are created which illustrate one of the most hazardous confined spaces of all--a confined space within a confined space.

This situation appears as tanks within pits, pipe assemblies or vessels within pits, etc. In this situation, not only do the potential hazards associated with the outer confined space require testing, monitoring, and control, but those of the inner space also require similar procedures.

Often, only the outer space is evaluated. When workers enter the inner space, they are faced with potentially hazardous conditions.

A good example of a confined space within a confined space is a vessel with a nitrogen purge inside a filtering water access pit. Workers entering the pit and/or the vessel should do so only after both spaces have been evaluated and proper control measures established.

### Hazards in One Space Entering another Space

During an examination of confined spaces in construction, one often encounters situations which are not always easy to evaluate or control. For instance, a room or area which classifies as a confined space may be relatively safe for work.

However, access passages from other areas outside or adjacent to the room could, at some point, allow the transfer of hazardous agents into the "**safe**" one. One such instance would be a pipe coming through a wall into a containment room.

Welding fumes and other toxic materials generated in one room may easily travel through the pipe into another area, causing it to change from a safe to an unsafe workplace.

A serious problem with a situation such as this is that workers working in the "**safe**" area are not aware of the hazards leaking into their area. Thus, they are not prepared to take action to avoid or control it.



### Session Conclusion

In this discussion, we have defined inherent and induced hazards in confined spaces. We have examined typical confined spaces on construction sites and we have described representative hazards within these confined spaces.

***Most of this text is credited to OSHA.***

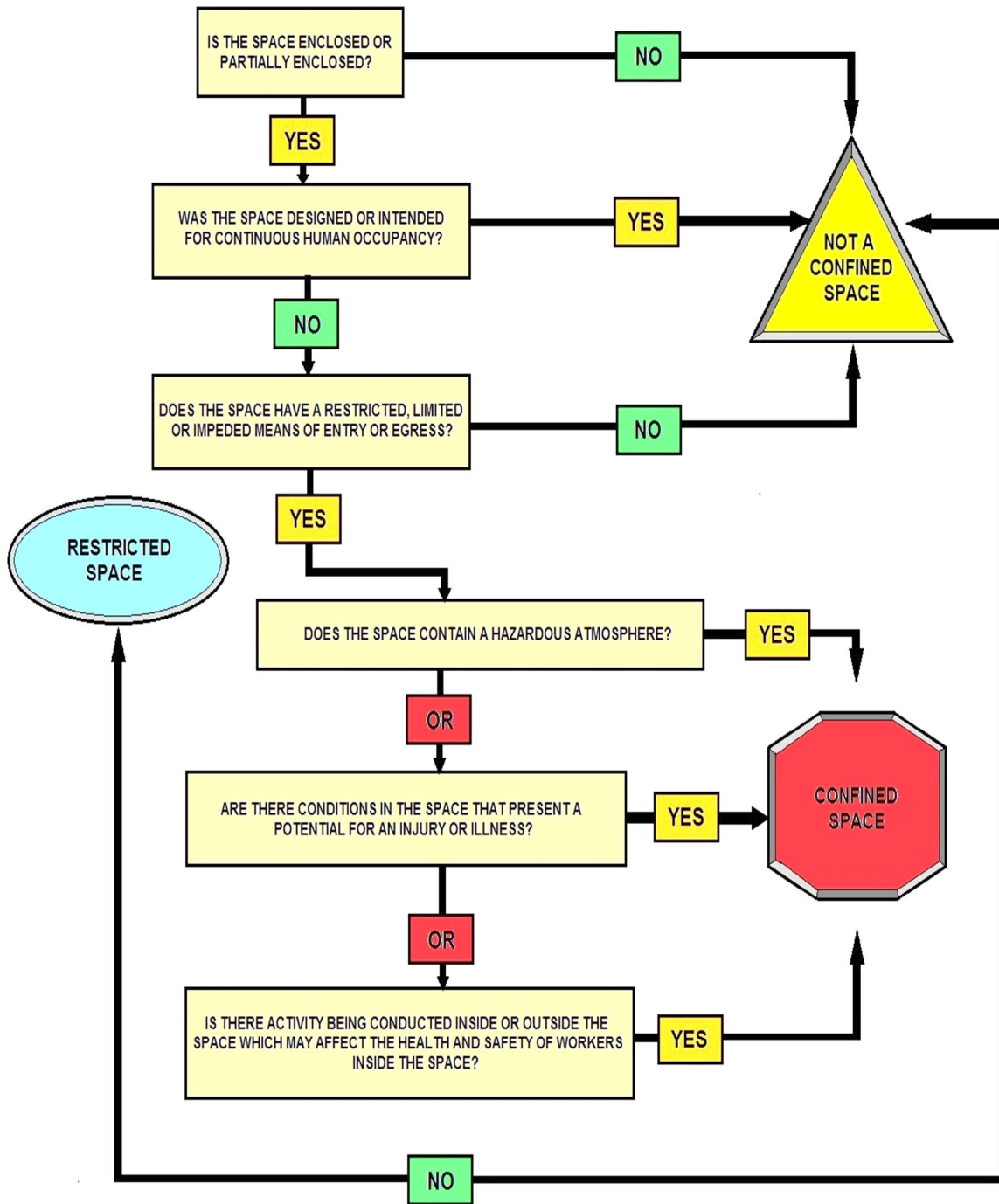

## HOW TO DETERMINE CONFINED SPACES

## Permitted Confined Space Entry Program Sub-Section

### Definition of Confined Spaces Requiring an Entry Permit

#### **Confined space:**

- ✓ Is large enough or so configured that an employee can bodily enter and perform work.
- ✓ Has limited or restricted means for entry or exit (i.e. tanks, vessels, silos, storage bins, hoppers, vaults, and pits are spaces that may have limited means of entry).
- ✓ Is not designed for continuous employee occupancy.

#### **Purpose**

The Permit Required Space (PRCS) Program is provided to protect authorized employees that will enter confined spaces and may be exposed to hazardous atmospheres, engulfment in materials, conditions which may trap or asphyxiate due to converging or sloping walls, or contains any other safety or health hazards.

Many workplaces contain confined spaces not designed for human occupancy which due to their configuration hinder employee activities including entry, work and exit. Asphyxiation is the leading cause of death in confined spaces.

#### **Subpart P applies to all open excavations in the earth's surface.**

- ✓ All trenches are excavations.
- ✓ All excavations are not trenches.

### Permit Required Confined Space Entry General Rules

#### ***During all confined space entries, the following safety rules must be strictly enforced:***

1. Only authorized and trained employees may enter a confined space or act as safety watchmen/attendants.
2. No smoking is permitted in a confined space or near entrance/exit area.
3. During confined space entries, a watchmen or attendant must be present at all times.
4. Constant visual or voice communication will be maintained between the safety watchmen and employees entering a confined space.
5. No bottom or side entry will be made or work conducted below the level any hanging material or material which could cause engulfment.
6. Air and oxygen monitoring is required before entering any permit-required confined space. Oxygen levels in a confined space must be between 19.5 and 23.5 percent. Levels above or below will require the use of an SCBA or other approved air supplied respirator. Additional ventilation and oxygen level monitoring is required when welding is performed. The monitoring will check oxygen levels, explosive gas levels and carbon monoxide levels. Entry will not be permitted if explosive gas is detected above one-half the Lower Explosive Limit (LEL).
7. To prevent injuries to others, all openings to confined spaces will be protected by a barricade when covers are removed.

# Appendix A to §1910.146

## Permit-Required Confined Space Decision Flow Chart

Note: Appendices A through F serve to provide information and non-mandatory guidelines to assist employers and employees in complying with the appropriate requirements of this section.

APPENDIX A TO §1910.146—PERMIT-REQUIRED CONFINED SPACE DECISION FLOW CHART

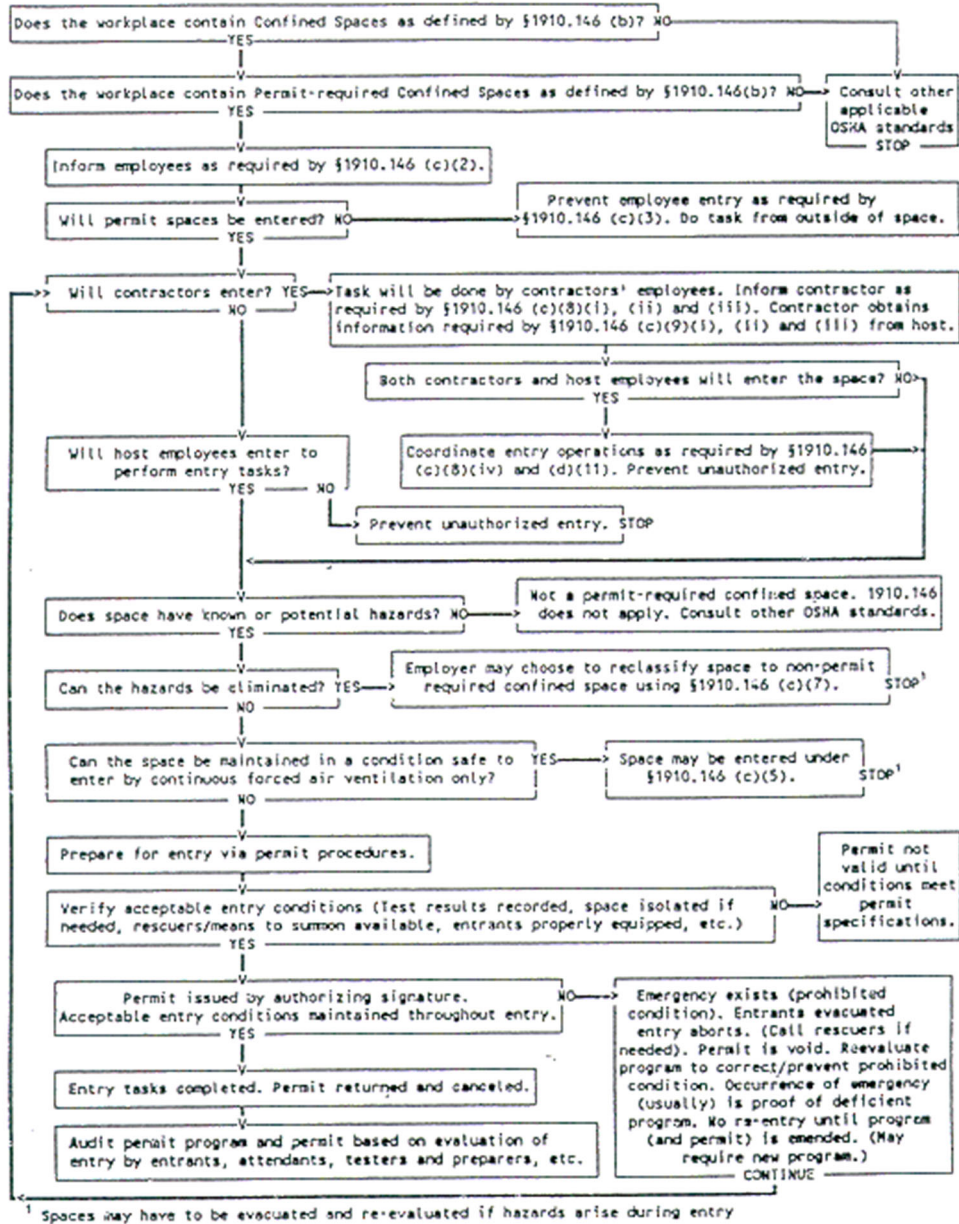

[58 FR 4549, Jan. 14, 1993; 58 FR 34846, June 29, 1993; 63 FR 66039, Dec. 1, 1998]

## Confined Space Entry Permit *Example*

Date & Time Issued		Date & time Expires	
Space I.D.		Supervisor	
Equipment Affected		Task	
Standby Team			
Pre-Entry Atmospheric Checks	Time (am - pm)		
	Oxygen		
	Explosive ( % LEL)		
	Toxic (PPM)		
	Testers Signature		
Pre-entry Fluid System Isolation		Yes	No
Pumps /lines blinded, blocked, disconnected			
Ventilation Source Established			
Mechanical Forced Air			
Natural Ventilation			
<b>Post Ventilation Pre-Entry Atmospheric Checks</b>			
<b>Time</b>			
<b>Oxygen (%)</b>			
<b>Explosive ( % LEL)</b>			
<b>Toxic (PPM)</b>			
<b>Tester Signature</b>			
<b>Communication Procedures</b> Established per specific Confined Space SOP			
Rescue Procedures established per specific Confined Space SOP			

Training Verification - for the following persons & space to be entered				YES	NO	
All persons entering Confined Space						
All persons acting as Supervisor for the Entry						
All persons assigned backup positions						
All persons assigned to monitor access and interior activities						
All persons assigned to emergency rescue team						
Equipment on Scene	YES	NO	NA	YES	NO	NA
Gas Monitor						
Safety Harness						
Fall Arrest Gear						
SCBAs						

Protective Clothing				Elect Gear Properly Rated			
Periodic Atmospheric Checks							
Time (am - pm)							
Oxygen							
Explosive ( % LEL)							
Toxic (PPM)							
Testers Signature							

A review of the work authorized by this permit and the information contained on this Entry Permit. Written instructions and safety procedures have been received and are understood. Entry cannot be approved if any squares are marked in the "No" column. This permit is not valid unless all appropriate items are completed.

**Permit Prepared By:** (Supervisor) \_\_\_\_\_

**Approved By:** (Unit Supervisor) \_\_\_\_\_

**This permit to be kept at job site.  
Return job site copy to Safety Office following job completion.**

Copies: Safety Office, Unit Supervisor, Job site

# Confined Space Duties & Responsibilities

## Examples of Assignments

### Employees

- Follow program requirements.
- Report any previously un-identified hazards associated with confined spaces.
- Do not enter any confined spaces that have not been evaluated for safety concerns.

### Management

- Provide annual Confined Space training to all employees that may need confined space training.
- Ensure confined space assessments have been conducted.
- Annually review this program and all Entry Permits.

### Rescue or Training Department

- Ensure proper training for entry & rescue teams.
- Provide proper equipment for entry & rescue teams.
- Ensure all permit required confined spaces are posted.
- Evaluate rescue teams and service to ensure they are adequately trained and prepared.
- Ensure rescue team at access during entry into spaces with Immediately Dangerous to Life or Health (IDLH) atmospheres.
- Provide annual confined space awareness training to all employees that may need confined space awareness training.

### Entry Supervisor

Entry supervisors are responsible for the overall permit space entry and must coordinate all entry procedures, tests, permits, equipment and other relevant activities.

#### ***The following entry supervisor duties are required:***

Know the hazards that may be faced during entry, including information on the mode, signs or symptoms, and consequences of the exposure.

- Verify by checking that the appropriate entries have been made on the permit, all tests specified by the permit have been conducted, and that all procedures and equipment specified by the permit are in place before endorsing the permit and allowing entry to begin.
- Terminate the entry and cancel the permit when the entry is complete or there is a need for terminating the permit.
- Verify that rescue services are available and that the means for summoning them are operable.



- Remove unauthorized persons who enter or attempt to enter the space during entry operations.

Determine whenever responsibility for a permit space entry operation is transferred and at intervals dictated by the hazards and operations performed within the space that entry operations remain consistent with the permit terms and that acceptable entry conditions are maintained.

### **Entry Attendants**

At least one attendant is required outside the permit space into which entry is authorized for the duration of the entry operation.

#### **Responsibilities include:**

- To know the hazards that may be faced during entry, including information on the mode, signs or symptoms, and consequences of the exposure.
- To be aware of possible behavioral effects of hazard exposure on entrants.
- To continuously maintain an accurate count of entrants in the permit space and ensure a means to accurately identify authorized entrants.
- To remain outside the permit space during entry operations until relieved by another attendant (once properly relieved, they may participate in other permit space activities, including rescue if they are properly trained and equipped).
- To communicate with entrants as necessary to monitor entrant status and alert entrants of the need to evacuate.
- To monitor activities inside and outside the space to determine if it is safe for entrants to remain in the space; orders the entrants to immediately evacuate if: the attendant detects a prohibited condition, detects entrant behavioral effects of hazard exposure, detects a situation outside the space that could endanger the entrants; or if the attendant cannot effectively and safely perform all the attendant duties.
- To summon rescue and other emergency services as soon as the attendant determines the entrants need assistance to escape the permit space hazards.
- To perform non-entry rescues as specified by that rescue procedure and entry supervisor and not to perform duties that might interfere with the attendants' primary duty to monitor and protect the entrants.

***Most of this text is credited to OSHA.***



## Entering a Confined Space Procedures

---



This space requires an emergency retrieval system, continuous air monitoring, and safety watch or two-way communication for safe entry.



Donning the personal protective equipment (PPE) necessary for confined space entry.

The full-body harness provides fully adjustable leg and shoulder straps for worker comfort and proper fit. Stamped steel sliding back D-ring and sub-pelvic strap provide optimum force distribution.



Example of a "**D-Ring**" and fall protection harness used when entering a confined space. The D-Ring provides a compatible anchor point for connecting devices such as lanyards or retractable lifelines. The shock absorbing lanyard provides a deceleration distance during a fall to reduce fall arrest forces for extra protection against injury.



Tripod-retrieval assembly in use for an entry into one of the many confined spaces.



Checking the cable tension and inertial locking mechanism of the retrieval assembly.

Correct use of this device prevents free-falls greater than 2 feet.



The entrant descends into the space as the attendant critiques the operation.



Dramatic rescue simulation using the tripod-retrieval system.



The entrant is now safely out of the space and is ready to return to his many other projects after this simulated exercise.

## Duties of the Person Authorizing or in Charge of the Entry

***The person who authorizes or is in charge of the permit entry confined space must comply with the following:***

1. Make certain that all pre-entry requirements as outlined on the permit have been completed before any worker is allowed to enter the confined space.
2. Make certain that any required pre-entry conditions are present.
3. If an in-plant/facility rescue team is to be used in the event of an emergency, make sure they would be available. If your Employer does not maintain an in-plant rescue team, dial 911 on any telephone for the Rescue Squad.
4. Make sure that any communication equipment which would be used to summon either the in-plant rescue team or other emergency assistance is operating correctly.
5. Terminate the entry upon becoming aware of a condition or set of conditions whose hazard potential exceeds the limits authorized by the entry permit.

If the person who would otherwise issue an entry permit is in charge of the entry and present during the entire entry, then a written permit is not required if that person uses a checklist as provided in the section on "**Permits**".

This person may also serve as the attendant at the site.

### **Special Considerations During A Permit Required Entry**

Certain work being performed in a permit entry confined space could cause the atmosphere in the space to change.

Examples of this are welding, drilling, or sludge removal. In these situations, air monitoring of the confined space should be conducted on a continuous basis throughout the time of the entry.

If the workers leave the confined space for any significant period of time, such as for a lunch or other break, the atmosphere of the confined space must be retested before the workers reenter the confined space.

### **Unauthorized Persons**

**Take the following actions when unauthorized persons approach or enter a permit space while entry is under way:**

1. Warn the unauthorized persons that they must stay away from the permit space,
2. Advise unauthorized persons that they must exit immediately if they have entered the space, and
3. Inform the authorized entrants and the entry supervisor if unauthorized persons have entered the permit space.

## Entrants

All entrants must be authorized by the entry supervisor to enter permit spaces, have received the required training, have used the proper equipment, and observed the entry procedures and permit requirements.

The following entrant duties are required:

Know the hazards that may be faced during entry, including information on the mode, signs or symptoms, and consequences of the exposure;

Properly use the equipment required for safe entry;  
Communicate with the attendant as necessary to enable the attendant to monitor the status of the entrants and to enable the attendant to alert the entrants of the need to evacuate the space if necessary;

Alert the attendant whenever; the entrant recognizes any warning signs or symptoms of exposure to a dangerous situation, or any prohibited condition is detected; and Exit the permit space as quickly as possible whenever the attendant or entry supervisor gives an order to evacuate the permit space, the entrant recognizes any warning signs or symptoms of exposure to a dangerous situation, the entrant detects a prohibited condition, or an evacuation alarm is activated.



## Hazards

- ✓ Explosive / Flammable Atmospheres
- ✓ Toxic Atmospheres
- ✓ Engulfment
- ✓ Asphyxiation
- ✓ Entrapment
- ✓ Slips & falls
- ✓ Chemical Exposure
- ✓ Electric Shock
- ✓ Thermal / Chemical Burns
- ✓ Noise & Vibration

## Hazard Control

### Engineering Controls

- Locked entry points
- Temporary ventilation
- Temporary Lighting

### Administrative Controls

- Signs
- Employee training
- Entry procedures
- Atmospheric Monitoring
- Rescue procedures
- Use of prescribed Personal Protective Equipment

### Entry Standard Operating Procedures

This program outlines:

- Hazards
- Hazard Control & Abatement
- Acceptable Entry Conditions
- Means of Entry
- Entry Equipment Required
- Emergency Procedures



# FRONT



**CONFINED SPACE  
ENTRY PERMIT**

DATE & TIME OF ISSUE

EQUIPMENT I.D.

EQUIPMENT LOCATION

EXPIRATION

WORK TO BE DONE \_\_\_\_\_

CONFINED SPACE APPROVAL

QUALIFIED PERSON \_\_\_\_\_

OTHER QUALIFIED PERSON \_\_\_\_\_

EMPLOYEE(S) TO ENTER \_\_\_\_\_

SUPERVISOR \_\_\_\_\_

CHECKLIST ON OTHER SIDE MUST BE COMPLETED BEFORE APPROVAL

# BACK



**CHECKLIST**

SPECIAL REQUIREMENTS	YES	NO
LOCKOUT - DE-ENERGIZER		
LINES BROKEN - CAPPED OR BLANKED		
PURGE - FLUSH AND VENT		
VENTILATION		
SECURE AREA		
BREATHING APPARATUS (SCBA)		
RESUCITATOR - INHALATOR		
ESCAPE HARNESS		
TRIPOD EMERGENCY ESCAPE UNIT		
LIFELINES		
FIRE EXTINGUISHERS		
LIGHTING		
PROTECTIVE CLOTHING (PPE)		

	P.E.L.	YES	NO
% OF OXYGEN	19.5% - 23.5%		
% OF L.E.L.	ANY % OVER 10		
CARBON MONOXIDE	35ppm		
HYDROGEN SULFIDE	10ppm		

**EXAMPLE OF A CONFINED SPACE ENTRY TAG**



## Permit Required Confined Space Entry General Rules

**During all confined space entries, the following safety rules must be strictly enforced:**

1. Only authorized and trained employees may enter a confined space or act as safety watchman/attendant.
2. No smoking is permitted in a confined space or near entrance/exit area.
3. During confined space entries, a watchman must be present at all times.
4. Constant visual or voice communication will be maintained between the safety watchman/attendant and employees entering a confined space.
5. No bottom or side entry will be made or work conducted below the level of any hanging material or material which could cause engulfment.
6. Air and oxygen monitoring is required before entering any permit-required confined space. Oxygen levels in a confined space must be between 19.5 and 23.5 percent. Levels above or below will require the use of an SCBA or other approved air supplied respirator.

Additional ventilation and oxygen level monitoring is required when welding is performed.

The monitoring will check oxygen levels, explosive gas levels and carbon monoxide levels. Entry will not be permitted if explosive gas is detected above one-half the Lower Explosive Limit (**LEL**), or 10% of a specific gas explosive limit.

7. To prevent injuries to others, all openings to confined spaces will be protected by a barricade when covers are removed.

### Confined Space Entry Procedures

***Each employee who enters or is involved in the entry must:***

1. Understand the procedures for confined space entry
2. Know the Hazards of the specific space
3. Review the specific procedures for each entry
4. Understand how to use entry and rescue equipment

### Confined Space Entry Permits

- ✓ Confined Space Entry Permits must be completed before any employee enters a permit-required confined space. The permit must be completed and signed by an authorized member of management before entry.
- ✓ Permits will expire before the completion of the shift or if any pre-entry conditions change.
- ✓ Permits will be maintained on file for 12 months.

## Contractor Entry

All work by non-company employees that involves the entry into confined spaces will follow the procedures of this program. The information of this program and specific hazards of the confined spaces to be entered will be provided to contractor management prior to commencing entry or work.



### Important Rescue Service Questions

What is the availability of the rescue service?

Is it unavailable at certain times of the day or in certain situations?

What is the likelihood that key personnel of the rescue service might be unavailable at times?

If the rescue service becomes unavailable while an entry is underway, does it have the capability of notifying the employer so that the employer can instruct the attendant to abort the entry immediately?

## Confined Space Training Sub-Section

### ***Training for Confined Space Entry includes:***

1. Duties of entry supervisor, entrant and attendants
2. Confined space entry permits
3. Hazards of confined spaces
4. Use of air monitoring equipment
5. First aid and CPR training
6. Emergency action & rescue procedures
7. Confined space entry & rescue equipment
8. Rescue training, including entry and removal from representative spaces

### **Confined Space Training and Education**

OSHA's General Industry Regulation, §1910.146 Permit-required confined spaces, contains requirements for practices and procedures to protect employees in general industry from the hazards of entry into permit-required confined spaces. This regulation does not apply to construction.

On May 4, 2015, OSHA issued a new standard for construction work in confined spaces, which became effective August 3, 2015. Confined spaces can present physical and atmospheric hazards that can be avoided if they are recognized and addressed prior to entering these spaces to perform work. The new standard, Subpart AA of 29 CFR 1926 will help prevent construction workers from being hurt or killed by eliminating and isolating hazards in confined spaces at construction sites similar to the way workers in other industries are already protected. These requirements are shown below.

### **§1926.21 Safety Training and Education. (Partial)**

(b)(6)(i) All employees required to enter into confined or enclosed spaces shall be instructed as to the nature of the hazards involved, the necessary precautions to be taken, and in the use of protective and emergency equipment required. The employer shall comply with any specific regulations that apply to work in dangerous or potentially dangerous areas.

(ii) For purposes of paragraph (b)(6)(i) of this section, "***confined or enclosed space***" means any space having a limited means of egress, which is subject to the accumulation of toxic or flammable contaminants or has an oxygen deficient atmosphere. Confined or enclosed spaces include, but are not limited to, storage tanks, process vessels, bins, boilers, ventilation or exhaust ducts, sewers, underground utility vaults, tunnels pipelines, and open top spaces more than 4 feet in depth such as pits, tubs, vaults, and vessels.

**OSHA's Construction Regulations** also contain requirements dealing with confined space hazards in underground construction (Subpart S), underground electric transmission and distribution work (§1926.956), excavations (Subpart P), and welding and cutting (Subpart J).

Further guidance may be obtained from American National Standard ANSI Z117.1-1989, Safety Requirements for Confined Spaces. This standard provides minimum safety requirements to be followed while entering, exiting and working in confined spaces at normal atmospheric pressure. This standard does not pertain to underground mining, tunneling, caisson work or other similar tasks that have established national consensus standards.

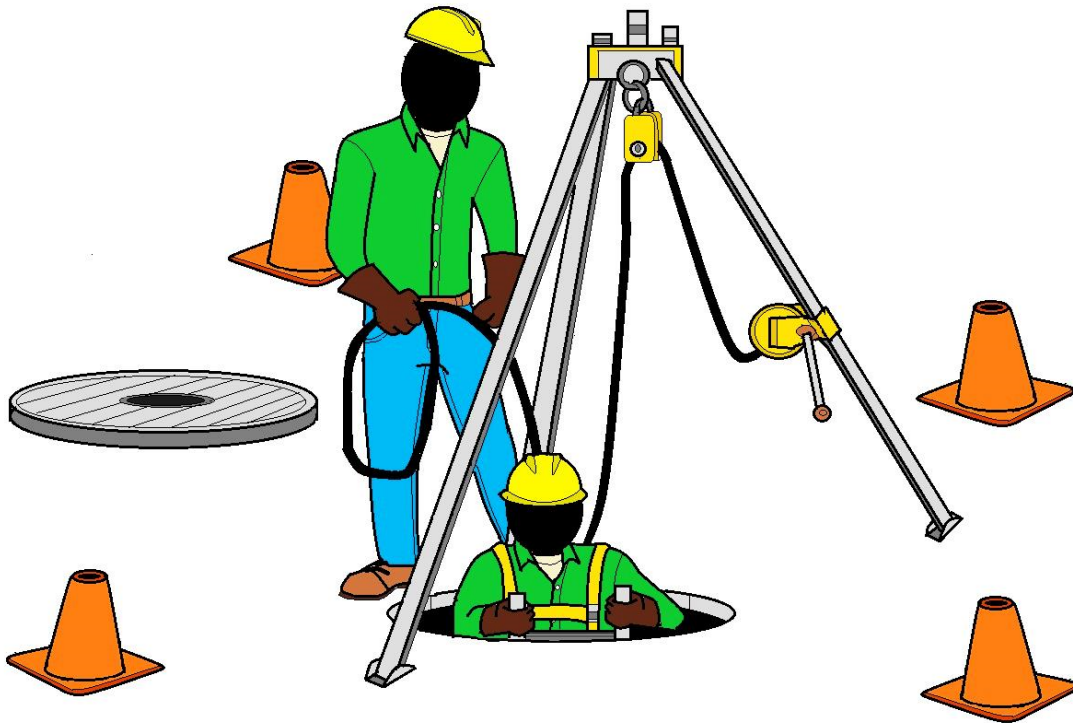

**ENTERING A CONFINED SPACE**

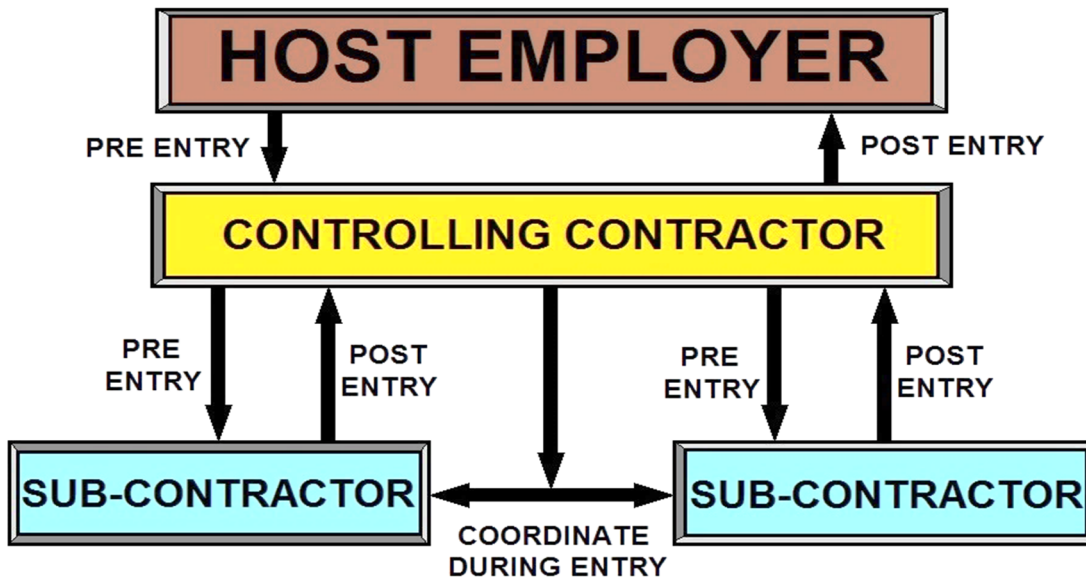

**COORDINATING CONFINED SPACE ENTRY ON JOBSITES**

## **Your Employer is Responsible for Certain Training Requirements**

***These are as follows:***

1. **GENERAL:** As an employer, your employer must ensure that all workers who must enter a permit entry confined space in the course of their work are informed of appropriate procedures and controls for entry into such spaces. These workers must be made aware of the fact that an unauthorized entry could be fatal, and that their senses are unable to detect and evaluate the severity of atmospheric hazards.

2. **TRAINING FOR AUTHORIZED ENTRANTS:** Your employer must ensure that all authorized entrants know the emergency action plan and have received training covering the following subjects prior to entering any permit entry confined space:

a. **Hazard Recognition:** Each worker must understand the nature of the hazard before entering and the need to perform appropriate testing to determine if it is safe to enter.

b. **Use of Personal Protective Equipment:** Each employee must be taught the proper use of all personal protective equipment required for entry or rescue, and the proper use of protective barriers and shields.

c. **Self-Rescue:** Each worker must be trained to get out of the confined space as rapidly as possible without help whenever an order to evacuate is given by the attendant, whenever an automatic evacuation alarm is activated, or whenever workers recognize the warning signs of exposure to substances that could be found in the confined space.

They must also be made aware of the toxic effects or symptoms of exposure to hazardous materials he could encounter in the confined space. This includes anything that could be absorbed through the skin or which could be carried through the skin by any solvents that are used. They must be trained to relay an alarm to the attendant and to attempt self-rescue immediately upon becoming aware of these effects.

d. **Special Work Practices or Procedures:** Each worker must be trained in any modifications of normal work practices that are necessary for permit entry confined space work.

3. **TRAINING FOR PERSONS AUTHORIZING OR IN CHARGE OF ENTRY:** In addition to other requirements already covered, the person authorizing or in charge of entry shall be trained to recognize the effects of exposure to hazards that could be in the confined space. They must also carry out all duties that the permit assigns to them.

**4. TRAINING FOR ATTENDANT** Any worker functioning as an attendant at a permit entry confined space must be trained in the company's emergency action plan, the duties of the attendant, and in;

a. Proper use of the communications equipment furnished for communicating with authorized workers entering the confined space or for summoning emergency or rescue services.

b. Authorized procedures for summoning rescue or other emergency services.

c. Recognition of the unusual actions of a worker which could indicate that they could be experiencing a toxic reaction to contaminants that could be present in the space.

d. Any training for rescuers, if the attendant will function as a rescuer also.

e. Any training for workers who enter the confined space, if the permit specifies that the duty of the attendant will rotate among the workers authorized to enter the confined space.



**Rescue practice training.** This photo is showing a sand bag being utilized as a dummy.

# CONFINED SPACE AUTHORIZED ENTRANT'S LOG EXAMPLE

CONFINED SPACE:

DATE:

TIME:

ENTRANT'S NAME (PRINT)	TIME IN	TIME OUT

ENTRY Attendant:

ENTRY Supervisor Review:

# CONFINED SPACE PROCEDURE CHECKLIST

Space \_\_\_\_\_ Date Last Modified \_\_\_\_\_

**Place check mark in all applicable areas**

Hazards	Personal Protective Equipment	
Explosive / Combustion Hazard	Air supplied Respirator	
Exposed Electrical Circuits	Air Purifying Respirator	
Unguarded Machine Parts	Welding Protection	
Atmospheric Hazard	Gloves	
Potential Atmospheric Hazard	Hard Hat	
Thermal Hazard	<b>Ventilation Requirements</b>	
Chemical Hazard	Continuous ___cu.ft/min Note: See <i>Ventilation Guidelines for Confined Spaces</i> for typical ventilation configurations and formulas.	
Fall Hazard		
Engulfment hazard	Note: Additional ventilation may be required for hot work, grinding or other operations that would produce airborne fumes, mist or dust. Entry Supervisor must assess additional ventilation requirements base on tasks to be performed in the space	
Converging Walls		
Floors slope-small cross-section		
Slip Hazard		
<b>Entry Path</b>		
Side entry	Vent Exhaust Point:	
Bottom entry	Vent Supply Point:	
Door	Space Volume	
Top open entry	<b>Initial Purge Time= <math>\frac{7.5 \times \text{(space volume)}}{\text{Effective Blower Capacity}}</math></b>	
Top manhole entry	<b>20 Air Changes per Hour (ACH) for duration of entry</b>	
Hinged hatch	<b>Minimum initial Purge Time= 20 Minutes</b>	
<b>Entry &amp; Rescue Equipment</b>		
Life Line	<b>Adequate Blower Capacity (ABC) = _____</b> <b>ABC = <math>\frac{\text{Space Volume} \times 20 \text{ ACH}}{60 \text{ minutes}}</math></b>	
<b>Acceptable Entry Conditions</b>		
Floor level opening barrier	Confined Space Entry permit posted	
Body Harness	Oxygen 19.5 - 23.5%	
Tripod	Lower Explosive Level %	
Man Winch	Toxic fumes/vapors Less than PEL	
Fall Arrest Unit	No engulfing material in space	
Emerg Retrieval Line	No hazardous chemicals or material	
Atmospheric Monitor	Drained - Flushed	
Blower /Saddle / Trunks	Rescue Team Available on Site	
Drop Light	Ventilation Established & Maintained	
Communication Gear	LOTO Electrical components in space	
Ladder	LOTO Mechanical Components in space	
Hand held radios	LOTO All pipes to and from space	
Portable Lighting		



## Other Hazards

### Flammable Atmospheres

A flammable atmosphere generally arises from enriched oxygen atmospheres, vaporization of flammable liquids, byproducts of work, chemical reactions, concentrations of combustible dusts, and desorption of chemical from inner surfaces of the confined space.

An atmosphere becomes flammable when the ratio of oxygen to combustible material in the air is neither too rich nor too lean for combustion to occur. Combustible gases or vapors will accumulate when there is inadequate ventilation in areas such as a confined space.

Flammable gases such as acetylene, butane, propane, hydrogen, methane, natural or manufactured gases or vapors from liquid hydrocarbons can be trapped in confined spaces, and since many gases are heavier than air, they will seek lower levels as in pits, sewers, and various types of storage tanks and vessels. In a closed top tank, it should also be noted that lighter than air gases may rise and develop a flammable concentration if trapped above the opening.

The byproducts of work procedures can generate flammable or explosive conditions within a confined space. Specific kinds of work such as spray painting can result in the release of explosive gases or vapors. Welding in a confined space is a major cause of explosions in areas that contain combustible gas.

Chemical reactions forming flammable atmospheres occur when surfaces are initially exposed to the atmosphere, or when chemicals combine to form flammable gases. This condition arises when dilute sulfuric acid reacts with iron to form hydrogen or when calcium carbide makes contact with water to form acetylene.

Other examples of spontaneous chemical reactions that may produce explosions from small amounts of unstable compounds are acetylene-metal compounds, peroxides, and nitrates. In a dry state, these compounds have the potential to explode upon percussion or exposure to increased temperature.

Another class of chemical reactions that form flammable atmospheres arise from deposits of pyrophoric substances (carbon, ferrous oxide, ferrous sulfate, iron, etc.) that can be found in tanks used by the chemical and petroleum industry. These tanks containing flammable deposits will spontaneously ignite upon exposure to air.

Combustible dust concentrations are usually found during the process of loading, unloading, and conveying grain products, nitrated fertilizers, finely ground chemical products, and any other combustible material.

High charges of static electricity, which rapidly accumulate during periods of relatively low humidity (below 50%) can cause certain substances to accumulate electrostatic charges of sufficient energy to produce sparks and ignite a flammable atmosphere.

These sparks may also cause explosions when the right air or oxygen to dust or gas mixture is present.

## Toxic Atmospheres

The substances to be regarded as toxic in a confined space can cover the entire spectrum of gases, vapors, and finely-divided airborne dust in industry. The sources of toxic atmospheres encountered may arise from the following:

1. The manufacturing process (for example, in producing polyvinyl chloride, hydrogen chloride is used as well as vinyl chloride monomer, which is carcinogenic).
2. The product stored [removing decomposed organic material from a tank can liberate toxic substances, such as hydrogen sulfide (H<sub>2</sub>S)].
3. The operation performed in the confined space (for example, welding or brazing with metals capable of producing toxic fumes).

During loading, unloading, formulation, and production, mechanical and/or human error may also produce toxic gases which are not part of the planned operation.

Carbon monoxide (CO) is a hazardous gas that may build up in a confined space. This odorless, colorless gas that has approximately the same density as air is formed from incomplete combustion of organic materials such as wood, coal, gas, oil, and gasoline; it can be formed from microbial decomposition of organic matter in sewers, silos, and fermentation tanks.

CO is an insidious toxic gas because of its poor warning properties. Early stages of CO intoxication are nausea and headache. CO may be fatal at as little as 1000 ppm or 10% in air, and is considered dangerous at 200 ppm or 2%, because it forms Carboxyhemoglobin in the blood which prevents the distribution of oxygen in the body.

CO is a relatively abundant colorless, odorless gas. Therefore, any untested atmosphere must be suspect. It must also be noted that a safe reading on a combustible gas indicator does not ensure that CO is not present. CO must be tested for specifically.

The formation of CO may result from chemical reactions or work activities, therefore fatalities due to CO poisoning are not confined to any particular industry. There have been fatal accidents in sewage treatment plants due to decomposition products and lack of ventilation in confined spaces.

In another area, the paint industry, varnish is manufactured by introducing the various ingredients into a kettle, and heating them in an inert atmosphere, usually town gas, which is a mixture of carbon dioxide and nitrogen.

In welding operations, oxides of nitrogen and ozone are gases of major toxicological importance, and incomplete oxidation may occur and carbon monoxide can form as a byproduct.

Another poor work practice, which has led to fatalities, is the recirculation of diesel exhaust emissions. Increased CO levels can be prevented by strict control of the ventilation and the use of catalytic converters.

# **Procedures for Atmospheric Testing. - 1910.146 App B**

## **OSHA Requirement**

### **Sub-Part Title: General Environmental Controls**

#### **Atmospheric testing is required for two distinct purposes:**

evaluation of the hazards of the permit space and verification that acceptable entry conditions for entry into that space exist.

(1) Evaluation testing. The atmosphere of a confined space should be analyzed using equipment of sufficient sensitivity and specificity to identify and evaluate any hazardous atmospheres that may exist or arise, so that appropriate permit entry procedures can be developed and acceptable entry conditions stipulated for that space.

Evaluation and interpretation of these data, and development of the entry procedure, should be done by, or reviewed by, a technically qualified professional (e.g., OSHA consultation service, or certified industrial hygienist, registered safety engineer, certified safety professional, certified marine chemist, etc.) based on evaluation of all serious hazards.

(2) Verification testing. The atmosphere of a permit space which may contain a hazardous atmosphere should be tested for residues of all contaminants identified by evaluation testing using permit specified equipment to determine that residual concentrations at the time of testing and entry are within the range of acceptable entry conditions.

Results of testing (i.e., actual concentration, etc.) should be recorded on the permit in the space provided adjacent to the stipulated acceptable entry condition.

(3) Duration of testing. Measurement of values for each atmospheric parameter should be made for at least the minimum response time of the test instrument specified by the manufacturer.

(4) Testing stratified atmospheres. When monitoring for entries involving a descent into atmospheres that may be stratified, the atmospheric envelope should be tested a distance of approximately 4 feet (1.22 m) in the direction of travel and to each side. If a sampling probe is used, the entrant's rate of progress should be slowed to accommodate the sampling speed and detector response.

(5) Order of testing. A test for oxygen is performed first because most combustible gas meters are oxygen dependent and will not provide reliable readings in an oxygen deficient atmosphere.

Combustible gases are tested for next because the threat of fire or explosion is both more immediate and more life threatening, in most cases, than exposure to toxic gases and vapors. If tests for toxic gases and vapors are necessary, they are performed last.

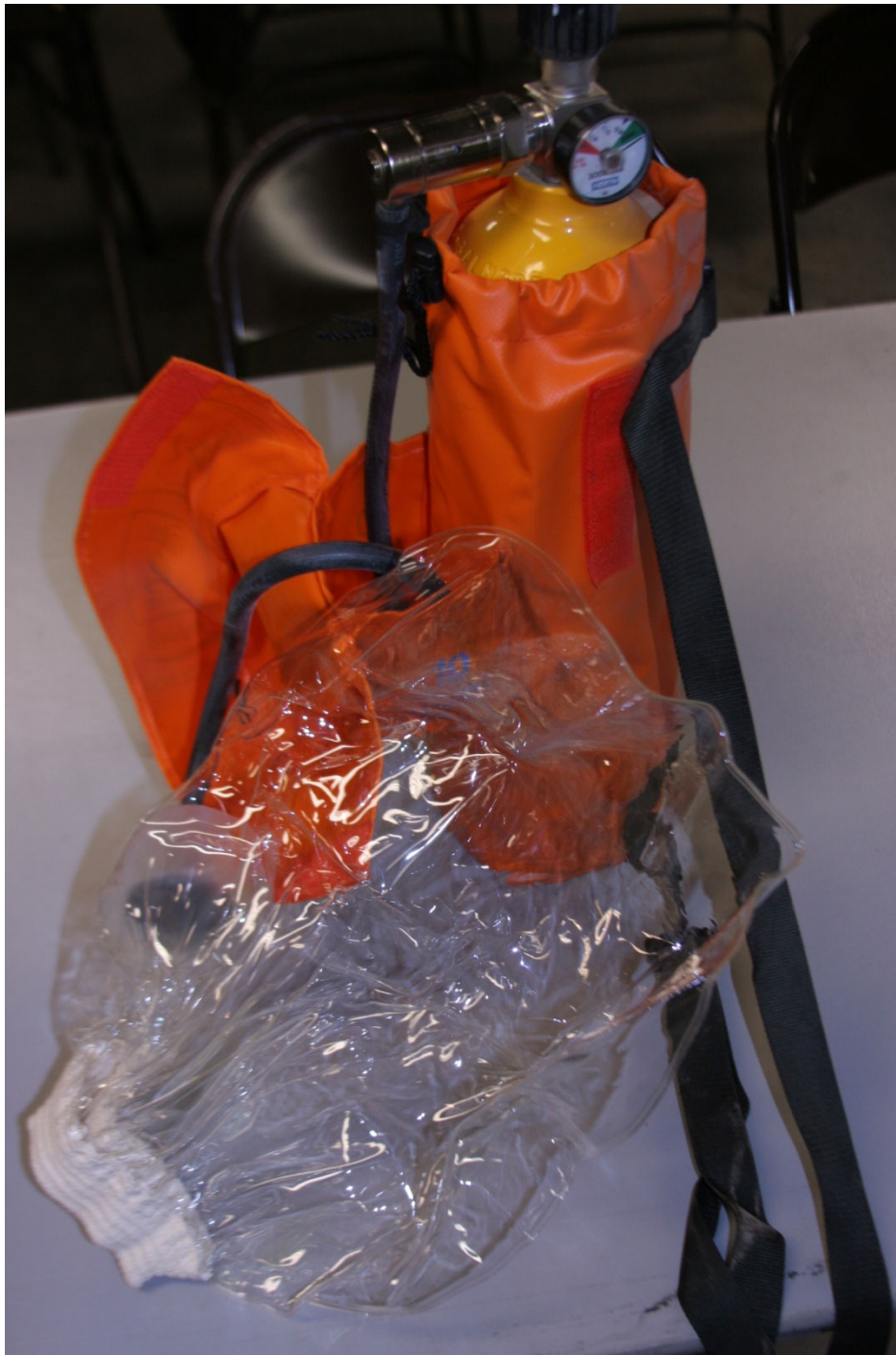

This is a ten-minute escape air pack or emergency air supply. The plastic bag will go over your head during an emergency and provide enough air to get out of the hole. There are smaller versions of this system.

## Confined Space Program *Multi-gas Meter Instructions*

### **Functional Buttons:**



On/Off	Press black button and hold until display tells you to RELEASE. Turn on in a clean-air environment.
Mode	Press "mode" button at display prompt.
E Button	Press (E) button at display prompt.
Alarm Mode	Red lights flash and unit beeps. Beeps are more frequent at higher contaminant levels, or lower oxygen level.



Forced air ventilation with a disposable air shaft.

## Typical Display of the TMX412



Location of gases on display.



Example of a clean air display. Carbon monoxide (**CO**) and hydrogen sulfide (**H<sub>2</sub>S**) are in ppm; oxygen (**O<sub>2</sub>**) and lower explosive limit (**LEL**) readings are percentage values. The battery-life indicator is just right of the oxygen display (i.e., 20.9); each line represents about one hour of service remaining.

## Peak Display Function

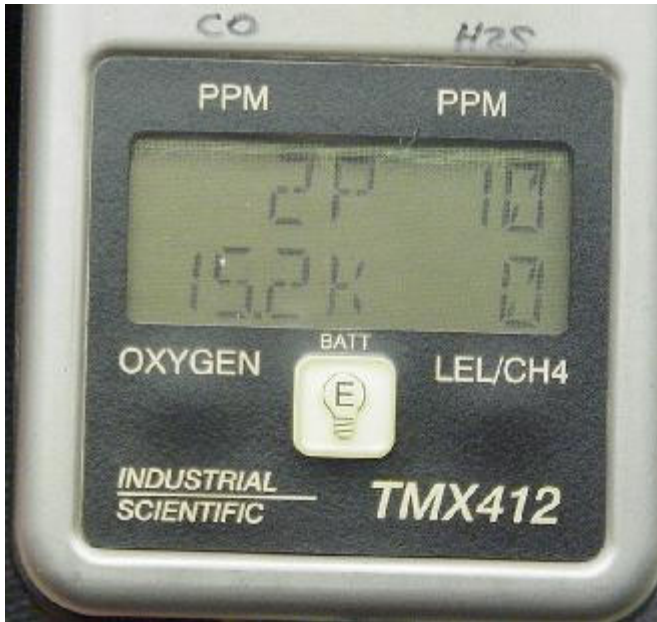

Example Display for Peak Mode: The display reads 2 ppm peak value for CO and 10 ppm peak value for H<sub>2</sub>S (top line); 15.2 % for oxygen and 0 % for LEL (bottom line).

- Use the PEAK function to display highest recorded readings for CO, H<sub>2</sub>S, and LEL, and the lowest reading for O<sub>2</sub>.
- Readings are not erased when you turn the unit off. You must use the PEAK CLEAR function to erase the memory.
- Make sure you check the peak readings have been cleared before you start your monitoring session.
- Press mode button until display reads "P" (top line), and "K" (bottom line) (see photo).

## Peak Clear Function

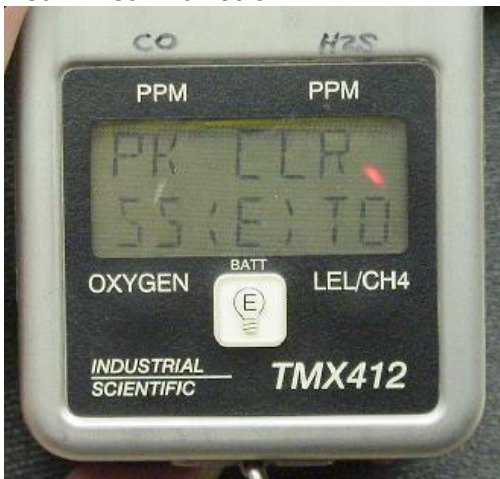

- Use the **PEAK CLEAR** function to clear peak readings from the internal memory. Readings are not erased when you turn the unit off. You must use the **PEAK CLEAR** function to erase the memory.
- Press mode button until display reads "**PK CLR PRESS (E) TO RESET**". After you press the (E) button, press mode button again until peak reading appears. Unit

should now read 0,0 (top line), and 21, 0 (bottom line) assuming this was performed in a clean-air environment.

**Zero Function and Calibration Function:**

- Zero and Calibration Functions are performed by Attendant or as specified by the Supervisor or manufacturer.
- Special equipment and experience is necessary to properly perform these functions.

**Documentation and Training:**

- Make sure you are familiar with all of our confined space entry equipment, including the multi-gas monitor, before use.
- Make sure to document your air monitoring data (e.g., peak values and other relevant data) on the Confined Space Air Monitoring Data Form.



You need continued atmospheric monitoring during the entry in any confined space. Most entrants will carry two gas monitors for increased safety.



## Atmospheric Testing Policy *Example*

Before entry, it is necessary to test the atmosphere in the confined space for oxygen levels, flammability, and/or any contaminants that have a potential to be present in that confined space. This testing must be done by a qualified person using equipment which has been approved for use in such areas.

The testing equipment itself should be checked to make sure it is working properly before using it. Follow the manufacturer's recommended procedures.

Testing of the confined spaces should be conducted throughout the entire portion of the space that workers will occupy during the entry. This testing shall be done without the use of ventilation systems.

Where the entry is vertical into the confined space, it is recommended that remote probes be used to measure the atmosphere at various levels. This is necessary because some gases and vapors are lighter or heavier than air and can accumulate at different levels in the confined space. Test outside the confined space to make sure the surrounding air is not contaminated.

Atmospheric conditions are considered unacceptable if oxygen levels are less than 19.5% or greater than 23.5%. Regulations define the following unacceptable levels of other hazards monitored:

1. A flammable gas, vapor or mist greater than 10% of its lower flammable limit (**LFL**). LFL means the minimum concentration of the flammable material which will ignite if an ignition source is present.
2. An airborne combustible dust at a concentration that obscures vision at a distance of five feet or less.
3. An atmospheric concentration of a substance greater than the allowed limit in the Material Safety Data Sheet for that substance.

If test results conclude that the atmospheric condition of the confined space is unacceptable, entry is prohibited until such conditions are brought into acceptable limits. This may be done by purging, cleaning and/or ventilating the space.

Purging refers to the method by which gases, vapors, or other airborne impurities are displaced from a confined space.

The confined space may also be made non-flammable, non-explosive or otherwise chemically non-reactive by displacing or diluting the original atmosphere with steam or gas that is non-reactive with respect to that space, a process referred to as "***inerting***".

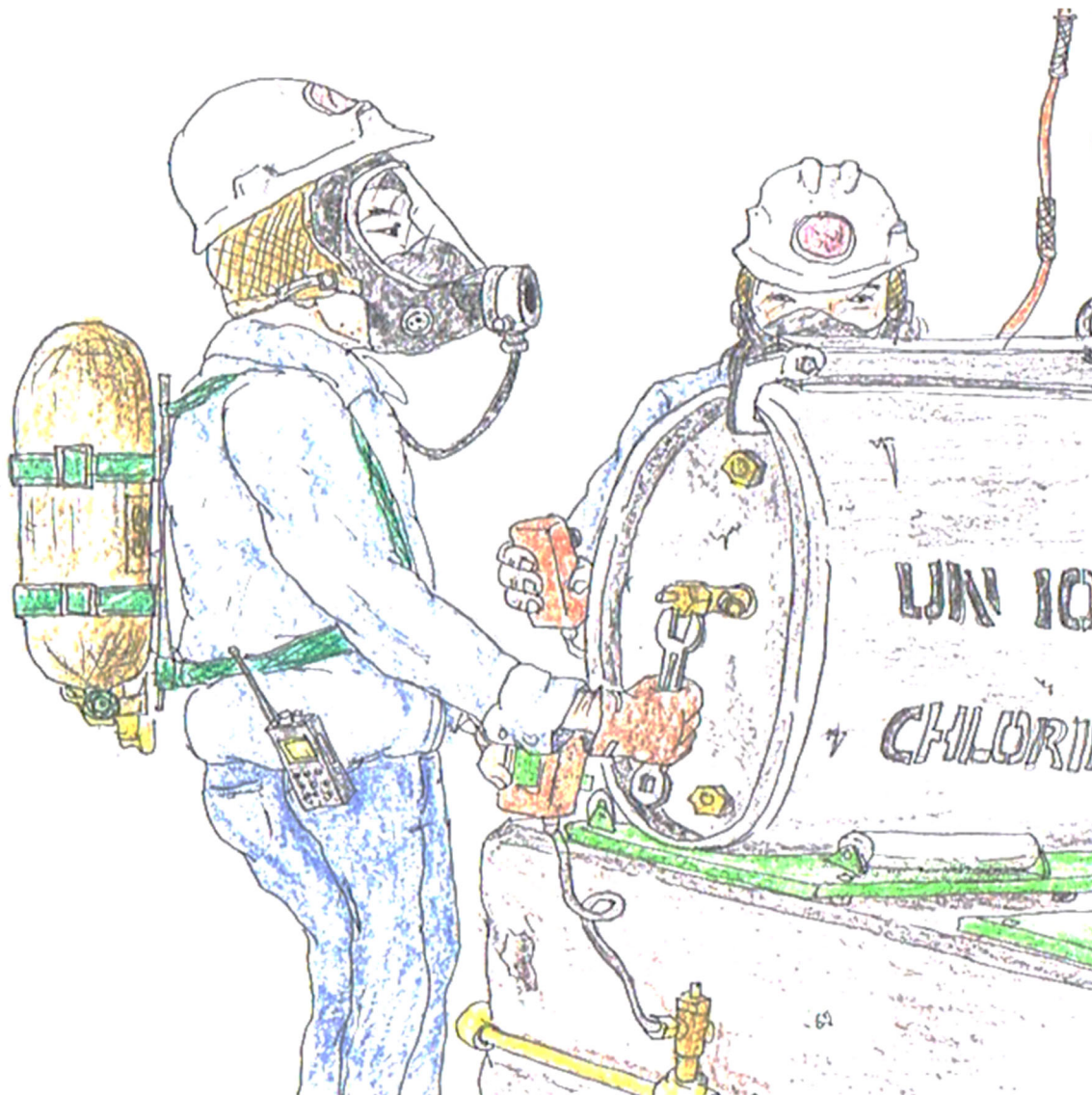

## Fire, Explosion, and Reactivity Hazards

Some chemicals present physical hazards such as the potential for fire, explosion, and reactivity. The SDS formerly called the MSDS explains these physical hazards.

**Flammable chemicals**—catch fire easily. The SDS will tell if it's flammable.

**Flash point**—the minimum temperature at which a liquid gives off enough vapors to burn. The lower the flash point, the more flammable the substance.

**Flammable limits**—the range of concentration of a substance in the air within which a substance can readily catch fire. Concentrations below or above the limits are less likely to ignite or burn.

## **Irritant (Corrosive) Atmospheres**

Irritant or corrosive atmospheres can be divided into primary and secondary groups. The primary irritants exert no systemic toxic effects (effects on the entire body).

Examples of primary irritants are chlorine, ozone, hydrochloric acid, hydrofluoric acid, sulfuric acid, nitrogen dioxide, ammonia, and sulfur dioxide. A secondary irritant is one that may produce systemic toxic effects in addition to surface irritation. Examples of secondary irritants include benzene, carbon tetrachloride, ethyl chloride, trichloroethane, trichloroethylene, and chloropropene.

Irritant gases vary widely among all areas of industrial activity. They can be found in plastics plants, chemical plants, the petroleum industry, tanneries, refrigeration industries, paint manufacturing, and mining operations.

Prolonged exposure at irritant or corrosive concentrations in a confined space may produce little or no evidence of irritation. This may result in a general weakening of the defense reflexes from changes in sensitivity. The danger in this situation is that the worker is usually not aware of any increase in his/her exposure to toxic substances.

### **Asphyxiating Atmospheres**

The normal atmosphere is composed approximately of 20.9% oxygen and 78.1% nitrogen, and 1% argon with small amounts of various other gases. Reduction of oxygen in a confined space may be the result of either consumption or displacement.

The consumption of oxygen takes place during combustion of flammable substances, as in welding, heating, cutting, and brazing. A more subtle consumption of oxygen occurs during bacterial action, as in the fermentation process.

Oxygen may also be consumed during chemical reactions as in the formation of rust on the exposed surface of the confined space (iron oxide). The number of people working in a confined space and the amount of their physical activity will also influence the oxygen consumption rate.

A second factor in oxygen deficiency is displacement by another gas. Examples of gases that are used to displace air, and therefore reduce the oxygen level are helium, argon, and nitrogen.

Carbon dioxide may also be used to displace air and can occur naturally in sewers, storage bins, wells, tunnels, wine vats, and grain elevators.

Aside from the natural development of these gases, or their use in the chemical process, certain gases are also used as inerting agents to displace flammable substances and retard pyrophoric reactions.

Gases such as nitrogen, argon, helium, and carbon dioxide, are frequently referred to as non-toxic inert gases but have claimed many lives. The use of nitrogen to inert a confined space has claimed more lives than carbon dioxide.

The total displacement of oxygen by nitrogen will cause immediate collapse and death.

## **Carbon Dioxide**

Carbon dioxide and argon, with specific gravities greater than air, may lie in a tank or manhole for hours or days after opening. Since these gases are colorless and odorless, they pose an immediate hazard to health unless appropriate oxygen measurements and ventilation are adequately carried out.

## **Oxygen Deprivation**

Oxygen deprivation is one form of asphyxiation. While it is desirable to maintain the atmospheric oxygen level at 21% by volume, the body can tolerate deviation from this ideal. When the oxygen level falls to 17%, the first sign of hypoxia is deterioration to night vision, which is not noticeable until a normal oxygen concentration is restored.

Physiologic effects are increased breathing volume and accelerated heartbeat.

Between 14-16% physiologic effects are increased breathing volume, accelerated heartbeat, very poor muscular coordination, rapid fatigue, and intermittent respiration.

Between 6-10% the effects are nausea, vomiting, inability to perform, and unconsciousness. Less than 6%, the effects are spasmodic breathing, convulsive movements, and death in minutes.

## **Mechanical Hazards**

If activation of electrical or mechanical equipment would cause injury, each piece of equipment should be manually isolated to prevent inadvertent activation before workers enter or while they work in a confined space. The interplay of hazards associated with a confined space, such as the potential of flammable vapors or gases being present, and the build-up of static charge due to mechanical cleaning, such as abrasive blasting, all influence the precautions which must be taken.

To prevent vapor leaks, flashbacks, and other hazards, workers should completely isolate the space. To completely isolate a confined space, the closing of valves is not sufficient.

All pipes must be physically disconnected or isolation blanks bolted in place. Other special precautions must be taken in cases where flammable liquids or vapors may re-contaminate the confined space.

The pipes blanked or disconnected should be inspected and tested for leakage to check the effectiveness of the procedure. Other areas of concern are steam valves, pressure lines, and chemical transfer pipes. A less apparent hazard is the space referred to as a void, such as double walled vessels, which must be given special consideration in blanking off and inerting.

## **Thermal Effects**

Four factors influence the interchange of heat between people and their environment. They are: (1) air temperature, (2) air velocity, (3) moisture contained in the air, and (4) radiant heat. Because of the nature and design of most confined spaces, moisture content and radiant heat are difficult to control.

As the body temperature rises progressively, workers will continue to function until the body temperature reaches approximately 102°F.

When this body temperature is exceeded, the workers are less efficient, and are prone to heat exhaustion, heat cramps, or heat stroke. In a cold environment, certain physiologic mechanisms come into play, which tend to limit heat loss and increase heat production.

The most severe strain in cold conditions is chilling of the extremities so that activity is restricted. Special precautions must be taken in cold environments to prevent frostbite, trench foot, and general hypothermia.



Proper signage is essential.

**Abbreviations:**

**PEL** - permissible exposure limit: Average concentration that must not be exceeded during 8-hour work shift of a 40-hour workweek.

**STEL** - Short-term exposure limit: 15-minute exposure limit that must not be exceeded during the workday.

**REL** - Recommended exposure limit: Average concentration limit recommended for up to a 10-hour workday during a 40-hour workweek.

**IDLH** - Immediately dangerous to life or health: Maximum concentration from which person could escape (in event of respiratory failure) without permanent or escape-impairing effects within 30 minutes.



SCBA Storage Box

## **Required Confined Space Equipment Policy *Example***

### **Air Testing Equipment**

All air-testing equipment should be calibrated in accordance with the manufacturer's instruction.

### **Oxygen Meters and Monitors**

The oxygen content of the air in a confined space is the first and most important constituent to measure before entry is made. The acceptable range of oxygen is between 19.5 and 23.5 percent. This content is measured before flammability is tested because rich mixtures of flammable gases or vapors give erroneous measurement results.

For example, a mixture of 90 percent methane and 10 percent air will test nonflammable because there is not enough oxygen to support the combustion process in the flammability meters. This mixture will not support life and will soon become explosive if ventilation is provided to the space. Before entry, spaces must be ventilated until both oxygen content and flammability are acceptable.

### **Flammability Meters**

Flammability meters are used to measure the amount of flammable vapors or gases in the atmosphere as a percent of the LEL/LFL. The oxygen content must be near 21 percent for results to be meaningful.

### **Toxic Air Contamination Testers**

Tests for toxic contaminants must be specific for the target toxin. The instrument manufacturer should be consulted for interferences. Therefore, it is important to know the history of the confined space so proper tests can be performed. Part of hazard assessment is to identify all possible contaminants that could be in the confined space.

## **Protective Devices**

### **Fall-Protection Equipment**

Fall-protection equipment for confined spaces should be the chest-waist harness type to minimize injuries from uncontrolled movements when it arrests a worker's fall. This type of harness also permits easier retrieval from a confined space than a waist belt. Adjustable lanyards should be used to limit free fall to two feet before arrest.

### **Respirators**

An industrial hygienist should select respirators on the basis of his or her evaluation of possible confined-space hazards. NIOSH-approved respirators should be identified in the approved procedure required by the confined-space entry permit. It is important to note that air-purifying respirators cannot be used in an oxygen deficient atmosphere.

### **Lockout/Tagout Devices**

Lockout/tagout devices permit employees to work safely on de-energized equipment without fear that the devices will be accidentally removed. Lock and tag devices are required to withstand a 50-pound pull without failure.

Devices used to block or restrain stored mechanical energy devices must be engineered for safety.

## **Safety Barriers**

Safety barriers separate workers from hazards that cannot reasonably be eliminated by other engineering controls.

Required barriers will be identified in the approved confined-space entry procedure.

## **Ground Fault Circuit Interrupters**

Ground fault circuit interrupter must be used for all portable electrical tools and equipment in confined spaces because most workers will be in contact with grounded surroundings.

## **Emergency Response Equipment**

### **Fire Extinguishers**

**"Hot work"** inside a confined space requires that an approved fire extinguisher and a person trained in its use be stationed in the confined space or in a suitable vantage point where he or she could effectively suppress any fire that might result from the work.

### **First Aid Equipment**

Blankets, first-aid kit, Stokes stretchers, and any other equipment that may be needed for first-response treatment must be available just outside the confined space. Medical and safety professionals should select equipment on the basis of their evaluations of the potential hazards in the confined space.

### **Retrieval Equipment**

A tripod or another suitable anchorage, hoisting device, harnesses, wristlets, ropes, and any other equipment that may be needed to make a rescue must be identified in the confined-space safe-entry procedures.



It is important that this equipment be available for immediate use. Harnesses and retrieval ropes must be worn by entrants unless they would increase hazards to the entrants or impede their rescue.



## Summary

### A Confined Space Entry Program Should Include the Following:

- Written confined space entry procedures
- Evaluation to determine whether entry is necessary
- Issuance of a confined space entry permit
- Evaluation of the confined space by a qualified person
- Testing and monitoring the air quality in the confined space to ensure:
  - Oxygen level is at least 19.5%
  - Flammable range is less than 10% of the LFL (lower flammable limit)
- Training of workers and supervisors in the selection and use of:
  - *safe entry procedures*
  - *respiratory protection*
  - *lifelines and retrieval systems*
  - *protective clothing*
- Training of employees in safe work procedures in and around confined spaces
- Training of employees in confined space rescue procedures
- Conducting safety meetings to discuss confined space safety
- Availability and use of proper ventilation equipment
- Monitoring the air quality while workers are in the confined space.

**Recommendation #2:** Employers should identify the types of confined spaces within their jurisdiction and develop and implement confined space entry and rescue programs.

**Discussion:** Employers may be required to enter confined spaces to perform either non-emergency tasks or emergency rescue.

Therefore, employers should identify the types of confined spaces within their jurisdiction and develop and implement confined space entry and rescue programs that include written emergency rescue guidelines and procedures for entering confined spaces. A confined space program, as outlined in NIOSH Publications 80-106 and 87-113, should be implemented. At a minimum, the following should be addressed:

1. Is entry necessary? Can the task be accomplished from the outside? For example, measures that eliminate the need for employees to enter confined spaces should be carefully evaluated and implemented if at all possible before considering human entry into confined spaces to perform non-emergency tasks.
2. If entry is to be made, has the air quality in the confined space been tested for safety based on the following:
  - oxygen supply at least 19.5%
  - flammable range for all explosive gases less than 10% of the lower flammable limit
  - absence of toxic air contaminants?
3. Is ventilation equipment available and/or used?
4. Is appropriate rescue equipment available?

5. Are supervisors being continuously trained in the selection and use of appropriate rescue equipment such as:

- SCBA's
- lifelines
- human hoist systems offering mechanical advantage
- protective clothing
- ventilation systems

6. Are employees being properly trained in confined space entry procedures?

7. Are confined space safe work practices discussed in safety meetings?

8. Are employees trained in confined space rescue procedures?

9. Is the air quality monitored when the ventilation equipment is operating?

The American National Standards Institute (ANSI) Standard Z117.1-1989 (Safety Requirements for Confined Spaces), 3.2 and 3.2.1 state, "*Hazards shall be identified for each confined space. The hazard identification process shall include, ... the past and current uses of the confined space which may adversely affect the atmosphere of the confined space; ... The hazard identification process should consider items such as ... the operation of gasoline engine powered equipment in or around the confined space.*"



D-Ring on the rear of the harness is necessary for the entrant to be retrieved from the confined space.

## Confined Space Post Quiz

### Confined space:

1. A confined space is large enough or so configured that an employee can \_\_\_\_\_.
2. A confined space is not designed for \_\_\_\_\_.
3. A permit required confined space (permit space) contains a material that has \_\_\_\_\_.

### Confined Space Hazards

4. Fatalities and injuries constantly occur among construction workers who are required to enter \_\_\_\_\_.
5. \_\_\_\_\_ are associated with specific types of equipment and the interactions among them. These hazards can be electrical, thermal, chemical, mechanical, etc.

### Typical Examples of Confined Workspaces

6. Confined workspaces in construction contain \_\_\_\_\_.
7. Workers must enter \_\_\_\_\_ found on the construction jobsite to perform a number of functions.
8. The ever-present possibility of \_\_\_\_\_ is one of the major problems confronting construction workers while working in vaults.
9. According to the text, a \_\_\_\_\_ normally considered a problem associated with confined spaces is material or equipment which may fall into the vault.
10. Manholes are necessary to provide a means of entry into and exit from vaults, tanks, and pits, but these confined spaces may present \_\_\_\_\_ which could cause injuries and fatalities.
11. The pipe assembly is one of the \_\_\_\_\_ encountered throughout the construction site,

12. Once inside a pipe assembly, workers are faced with \_\_\_\_\_, often caused by purging with argon or another inert gas.

13. \_\_\_\_\_ is another problem to which the worker is exposed when inside a pipe assembly.

14. The worker may suffer \_\_\_\_\_ caused by heat within the pipe run.

15. Tanks are \_\_\_\_\_ that are used for a variety of purposes, including the storage of water and chemicals.

16. According to the text, oxygen-deficient atmospheres, along with toxic and explosive atmospheres created by the substances stored in the tanks, present hazards to workers.

A. True                      B. False

17. Heat in tanks may cause \_\_\_\_\_, particularly on a hot day.

18. Entry supervisors must coordinate all entry procedures, tests, \_\_\_\_\_, equipment, and other activities related to the permit space entry.

19. Before endorsing the permit and allowing entry to begin, the \_\_\_\_\_ must check that all appropriate entries have been made on the permit, all tests specified by the permit have been conducted, and that all procedures and equipment specified by the permit are in place.

20. A responsibility of the entry attendant is to know the hazards that may be faced during entry, including information on the mode, signs or symptoms, and consequences of the exposure.

A. True                      B. False

### **Confined Space Chapter Answers**

1. Bodily enter and perform work, 2. Continuous employee occupancy, 3. The potential for engulfing an entrant, 4. Confined spaces, 5. Inherent hazards, 6. Both inherent and induced hazards, 7. A variety of vaults, 8. An oxygen-deficient atmosphere, 9. Hazard, 10. Serious hazards, 11. Most frequently unrecognized types of confined spaces, 12. Potential oxygen-deficient atmospheres, 13. Electrical shock, 14. Heat prostration, 15. Another type of confined workspace, 16. True, 17. Heat prostration, 18. Permits, 19. Entry supervisor, 20. True

# CHAPTER 11 – EXCAVATION AND TRENCHING SECTION

**Section Focus:** You will learn the basics of proper excavation and trenching safety. At the end of this section, you the student will be able to understand and describe commonly found trench safety procedures and devices. There is a post quiz at the end of this section to review your comprehension and a final examination in the Assignment for your contact hours.

**Scope/Background:** The OSHA SUBPART P - 29 CFR 1926.650-652 requires the employer to set up an excavation safety program to protect employees from cave-in and other excavation dangers.



## OSHA SUBPART P - 29 CFR 1926.650-652 COMPETENT PERSON TRAINING

### PREFACE

Anyone who has done excavation work will tell you that once the first bucket of dirt is out of the ground, you never know what surprises await. Tales of unmarked utilities, unexpected rock and other nightmares are common. The greatest variable, however, is the type of excavation or trenching will be done and how to protect yourself for a cave-in.

The OSHA excavation standard was revised because excavating is the most dangerous of all construction operations. More workers are killed or seriously injured in and around excavations than in any other construction work. The second reason that OSHA revised the existing standard was to clarify the requirements. The revised standard makes the standard easier to understand. The new standard uses performance criteria where ever possible. This added flexibility provides employers with options when classifying soil and when selecting methods to protect the employee from cave-ins.

Although the standard has been clarified and employers have options when meeting some of the requirements, employers must realize that the employee must be protected at all times.

Some employers have a mindset of not needing this training until they are caught by OSHA, which is equivalent to buying car insurance only after a car collision.

Excavation decisions will have to be made right from the planning stages through completion of the work. Some sections of the standard require that documentation be kept. In some situations professional engineers will be required to plan or design the excavation and/or method of protecting the worker (such as when an excavation exceeds 20 feet in depth).

The purpose of this session is to provide you with information about the OSHA excavation standard. This program is not designed or intended to provide participants with all the information, rules, regulations and methods that they may need to know to perform all excavation work safely.

Every plan involving excavation must be studied carefully to determine the specific hazards for each job.



Supporting utilities is mandatory.

## Excavation Facts

### Every year in the United States:

- ✓ 100 to 500 people are killed in an excavation cave-in.
- ✓ 1000 to 5000 employees are seriously injured.

The average worker that is killed by a cave-in is a 20 to 30 year old male who has had little or no training at all. Most deaths occur in trenches 5 feet to 15 feet in depth.

### Cave-ins cause deaths and injuries by:

- ✓ Suffocation
- ✓ Crushing
- ✓ Loss of circulation
- ✓ Falling objects

One cubic foot (12" x 12" x 12") can weigh between 90 and 140 pounds. Therefore, one cubic yard (3' x 3' x 3') weighs as much as a backhoe (approximately 3000 pounds).

### Subpart P applies to all open excavations in the earth's surface.

- ✓ All trenches are excavations.
- ✓ All excavations are not trenches.

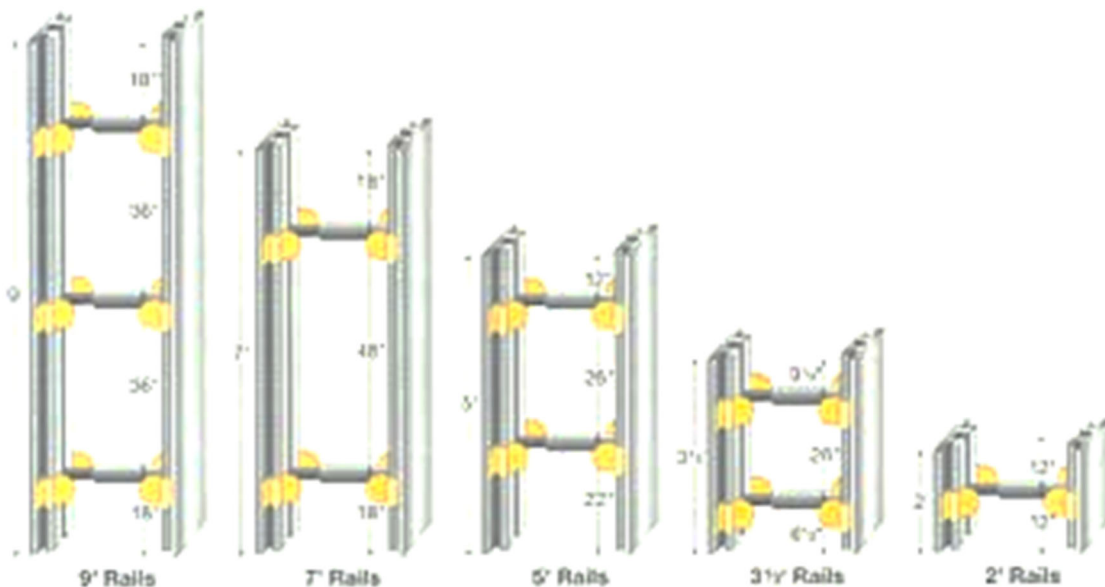



Notice that employees are wearing hard hats but no ladders are present. Spoil piles are too close to the hole. Forgot the ladder.



Notice the ladder it should be three rungs out and tied but not staked.



## Competent Person

Competent person means one who is capable of identifying existing hazards in the surroundings or working conditions which are unsanitary, hazardous, or dangerous to employees and has authorization to take prompt corrective measures to eliminate them.

In order to be a "**Competent Person**" for the purpose of this standard, one must have specific training in and be knowledgeable about soils analysis, the use of protective systems and the requirements of 29 CFR Part 1926.650-652 Subpart P.

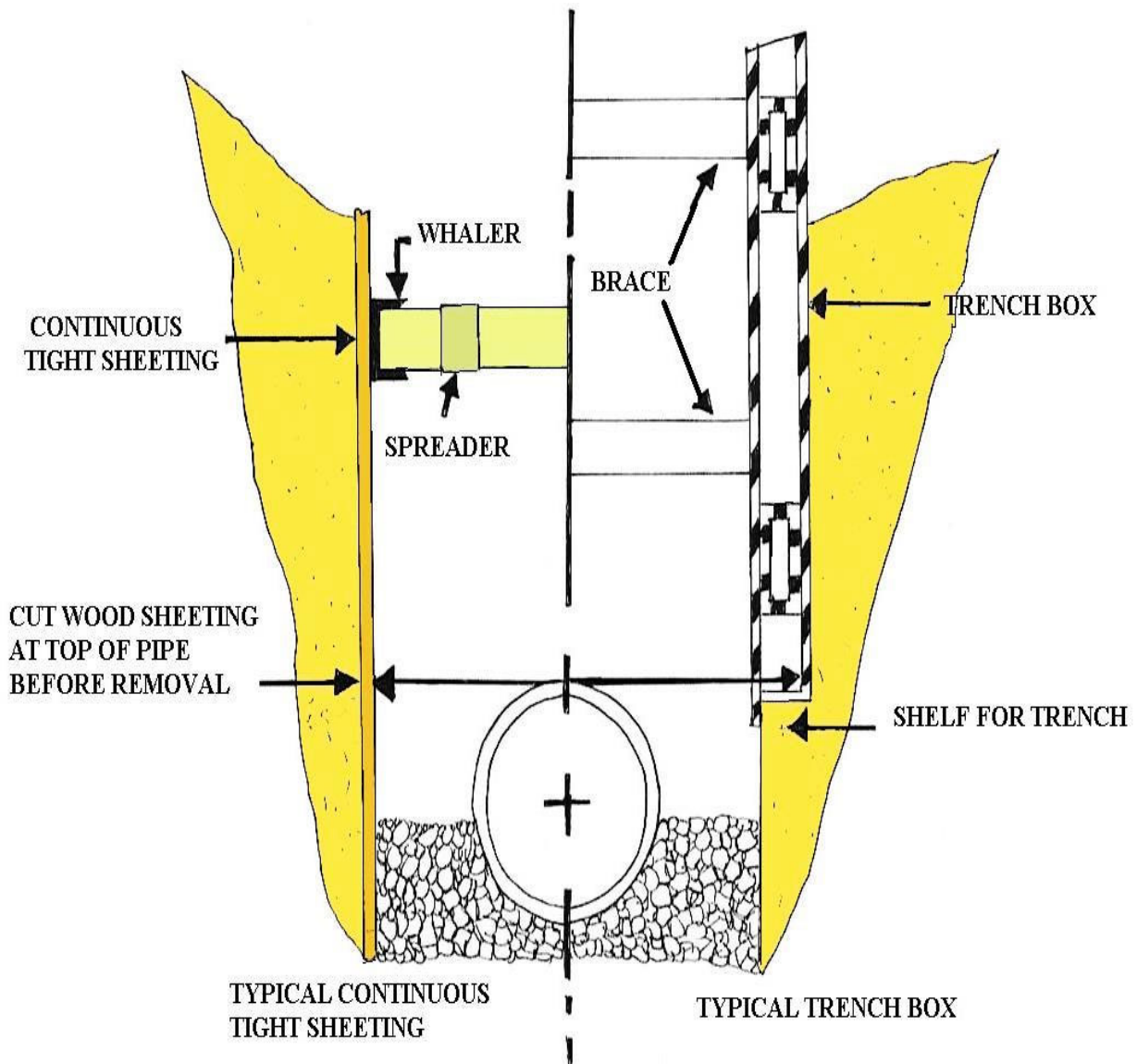

## Competent Person Duties

- Performs daily inspections of the protective equipment, trench conditions, safety equipment and adjacent areas.
- Inspections shall be made prior to the start of work and as needed throughout the shift.
- Inspections shall be made after every rainstorm or other hazard occurrence.
- Knowledge of emergency contact methods, telephone or radio dispatch.
- Removes employees and all other personnel from hazardous conditions and makes all changes necessary to ensure their safety.
- Insures all employees have proper protective equipment, hard-hats, reflective vests, steel-toed boots, harnesses, eye protection, hearing protection and drinking water.
- Categorize soil conditions and conduct visual and manual tests.
- Determine the appropriate protection system to be used.
- Maintain on-site records of inspections and protective systems used.
- Maintain on-site Hazard Communication program, Material Safety Data Sheets and a Risk Management Plan, if necessary.
- Maintain current First Aid and CPR certifications. Maintain current Confined Space certification training.

## Scope of Work

1. During excavation work a competent person shall be on the job site at all times when personnel are working within or around the excavation. This is necessary in order to monitor soil conditions, equipment and protection systems employed.
2. The estimated locations of utility installations, such as sewer, telephone, fuel, electric, water lines, or any other underground installation that reasonably may be expected to be encountered during excavation work, shall be determined prior to opening an excavation.
3. Adequate precautions shall be taken to protect employees working in excavations, against the hazards posed by water accumulation.
4. Employees shall be protected from excavated or other materials or equipment that could pose a hazard by falling or rolling into excavations. Protection shall be provided by placing and keeping such material or equipment at least two (2') feet from the edge of excavations.
5. A stairway, ladder, or ramp shall be used as a means of access or egress in trench excavations that are four (4') feet or more in depth. The ladder(s), stairway(s), or ramp shall be spaced so that no employee in the trench excavation is more than twenty five (25') feet from a means of egress. When ladder(s) are employed, the top of the ladder shall extend a minimum of three (3') feet above the ground and shall be properly secured.
6. When excavations are exposed to vehicular traffic, each employee shall wear a warning vest made with reflective material or highly visibility material. All personnel within the construction area shall wear a hard-hat at all times.
7. Employees shall not be permitted underneath loads handled by lifting or digging equipment. Employees shall be required to stand away from any vehicle being loaded or unloaded to avoid being struck by any spillage or falling materials.
8. In excavations where oxygen deficiency or gaseous conditions exist, or could be reasonably expected to exist, air in the excavation shall be tested.
9. Where oxygen deficiency (atmospheres containing less than 19.5 percent oxygen) exists, the area must be continuously ventilated until the oxygen levels are above 19.5 percent.
10. Where a gaseous condition exists, the area shall be ventilated until the flammable gas concentration is below 20 percent of the lower flammable limit.

11. Whenever oxygen deficiency or gaseous conditions exist or could reasonably exist, the area shall be monitored continuously to assure that employees are protected.
12. Where the stability of adjoining buildings, walls or other structures are endangered by excavation operations, support systems such as shoring, bracing, or underpinning shall be provided to ensure the stability of such structures for the protection of employees.
13. Sidewalks, pavement and appurtenant structures shall not be undermined unless a support system such as shoring is provided to protect employees from the possible collapse of such structures.



Always wait for the buried utilities to be marked before excavation begins. Believe it or not, this crew dug 9 feet deep before the Locator showed up and marked fiber optics in the same trench. Notice that the employees do not have hard hats, ladders, or any protective systems. Several major OSHA violations.

## Personnel Protection

Employees in excavations shall be protected from cave-ins by an adequate protective system, which shall be inspected by a competent person.

The use of protective systems is required for all excavations, in excess of five (5') feet, except when excavation is within stable rock.

Trench excavation less than five (5') feet in depth may not require the use of protective systems, unless there is evidence of a potential cave-in. The competent person shall determine the need for the use of protective systems when such conditions exist.

When sloping, benching or protective systems are required, refer to requirements in CFR 1926.652 (OSHA Construction Standards).

Whenever support systems, shield systems, or other protective systems are being used, a copy of the manufacturer's specifications, recommendations, and limitations sheet shall be in written form and maintained at the job site.



This poor soul is probably going to be a short timer here on earth. He is sitting on the sewer main in a bell shaped hole under a steel plate which cars are driving over. No protection at all. There was a ladder in the trench but was about 50 feet away. He wouldn't make it out of a cave-in unless he had wings.

## Excavation Protection Systems

The three basic protective systems for excavations and trenches are sloping and benching systems, shoring, and shields. The protective systems shall have the capacity to resist without failure all loads that are intended or could reasonably be expected to be applied to or transmitted to the system. Every employee in an excavation shall be protected from cave-ins by an adequate protective system.

### Exceptions to Using Protective System:

- Excavations are made entirely in stable rock.
- Excavations are less than 5 feet deep and declared safe by a competent person.

### Sloping and Benching Systems

There are four options for sloping:

- Slope to the angle required by the standard for Type C, which is the most unstable soil type.
- The table provided in Appendix B of the standard may be used to determine the maximum allowable angle (after determining the soil type).
- Tabulated data prepared by a registered professional engineer can be utilized.
- A registered professional engineer can design a sloping plan for a specific job.

Sloping and benching systems for excavations five (5) to twenty (20) feet in depth must be constructed under the instruction of a designated competent person. Sloping and benching systems for excavations greater than twenty (20) feet must be designed and stamped by a registered professional engineer. Sloping and benching specifications can be found in Appendix B of the OSHA Standard (Subpart P).

### Shoring Systems

Shoring is another protective system or support system. Shoring utilizes a framework of vertical members (uprights), horizontal members (whales), and cross braces to support the sides of the excavation to prevent a cave-in. Metal hydraulic, mechanical or timber shoring are common examples.



This is my favorite photograph of all. Here are two men in a 30 foot deep trench without any protection or ladders. They are lucky to have a rope. Please do not work in this dangerous environment.

The different examples of shoring are found in the OSHA Standard under these appendices:

**APPENDIX C** - Timber Shoring for Trenches

**APPENDIX D** - Aluminum Hydraulic Shoring for Trenches

**APPENDIX E** - Alternatives to Timber Shoring

### **Shield Systems (Trench Boxes)**

Shielding is the third method of providing a safe workplace. Unlike sloping and shoring, shielding does not prevent a cave-in. Shields are designed to withstand the soil forces caused by a cave-in and protect the employees inside the structure. Most shields consist of two flat, parallel metal walls that are held apart by metal cross braces.

Shielding design and construction is not covered in the OSHA Standards. Shields must be certified in design by a registered professional engineer and must have either a registration plate on the shield or registration papers from the manufacturer on file at the jobsite office. **ANY REPAIRS OR MODIFICATIONS MUST BE APPROVED BY THE MANUFACTURER.**

### **Safety Precautions for Shield Systems**

- Shields must not have any lateral movement when installed.
- Employees will be protected from cave-ins when entering and exiting the shield (examples - ladder within the shield or a properly sloped ramp at the end).
- Employees are not allowed in the shield during installation, removal, or during any vertical movement.
- Shields can be 2 ft. above the bottom of an excavation if they are designed to resist loads at the full depth and if there are no indications of caving under or behind the shield.
- The shield must extend at least 18 inches above the point where proper sloping begins (the height of the shield must be greater than the depth of the excavation).
- The open end of the shield must be protected from the exposed excavation wall. The wall must be sloped, shored, or shielded. Engineer designed end plates can be mounted on the ends of the shield to prevent cave-ins.



### **Personal Protective Equipment**

It is **OSHA** policy for you to wear a hard hat, safety glasses, and work boots on the jobsite. Because of the hazards involved with excavations, other personal protective equipment may be necessary, depending on the potential hazards present (examples-goggles, gloves, and respiratory equipment).

## Excavation & Trenching Guidelines

This section outlines procedures and guidelines for the protection of employees working in and around excavations and trenches. This section requires compliance with OSHA Standards described in Subpart P (**CFR 1926.650**) for the construction industry.

Safety compliance is mandatory to ensure employee protection when working in or around excavations.

The competent person(s) must be trained in accordance with the OSHA Excavation Standard, and all other programs that may apply (examples Hazard Communication, Confined Space, and Respiratory Protection), and must demonstrate a thorough understanding and knowledge of the programs and the hazards associated.

All other employees working in and around the excavation must be trained in the recognition of hazards associated with trenching and excavating.

### REFERENCES

- 29 CFR 1926.650, Subpart P - Excavations
- Excavation Equipment Manufacturer Safety Procedures

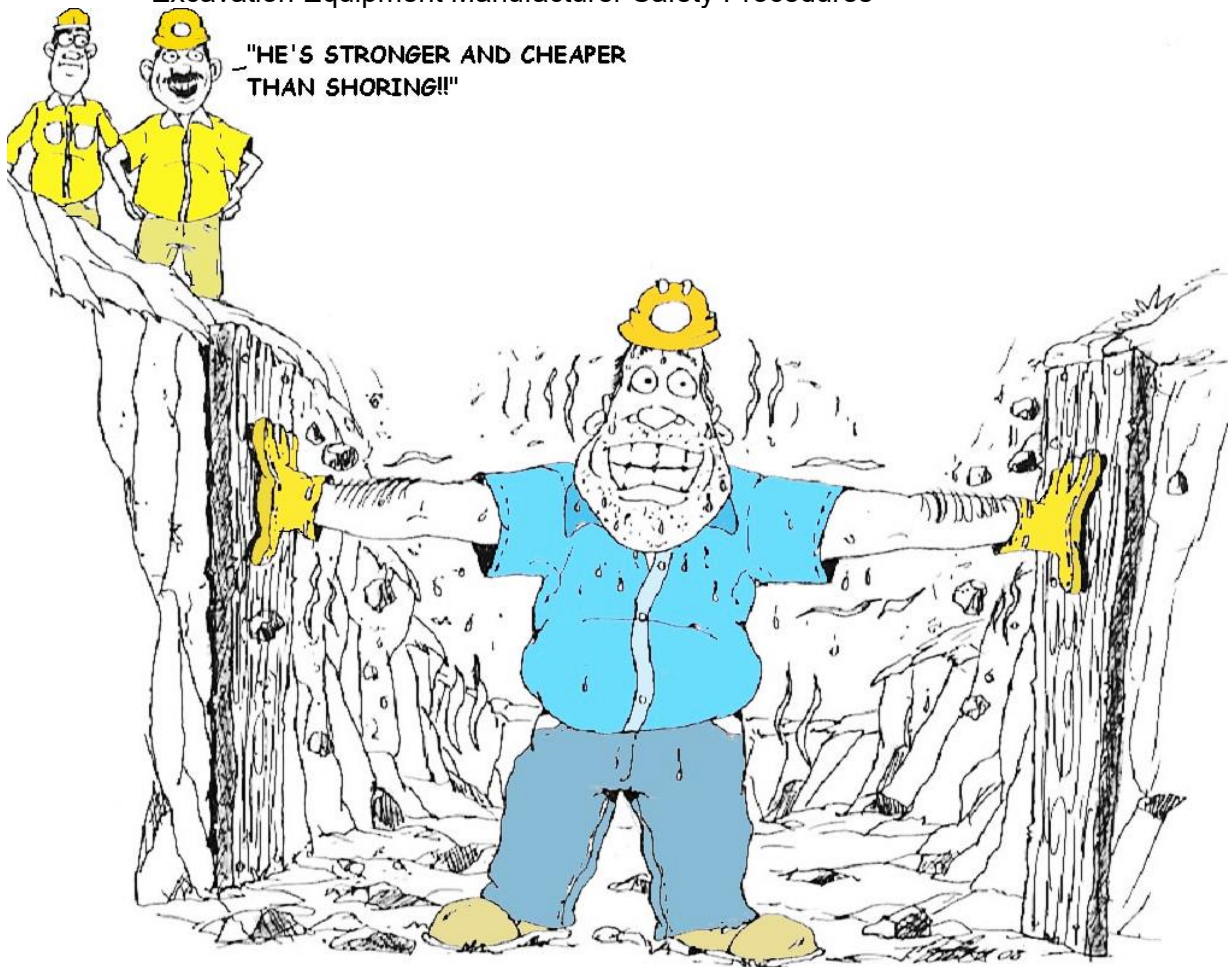

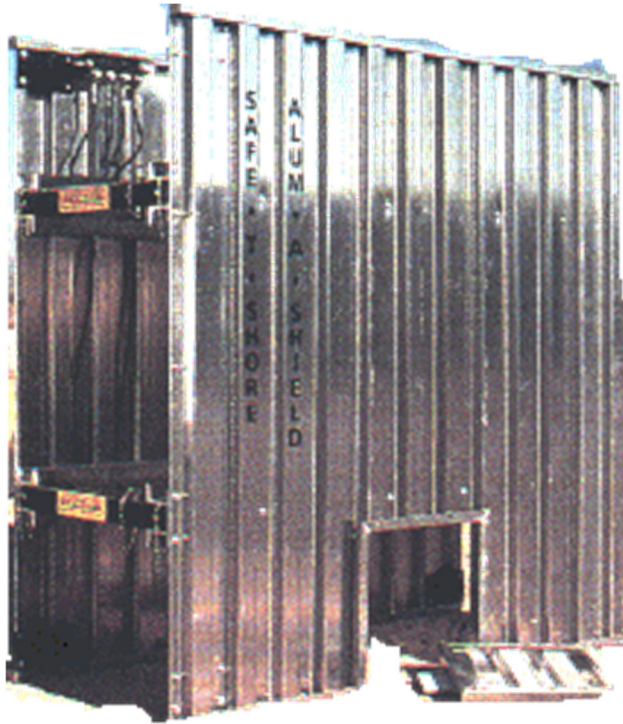

*Trench Shields and Boxes*





## Hazards

One of the reasons OSHA requires a competent person on-site during excavation & trenching are the numerous potential hazardous that may be encountered or created.

### Hazards include:

- Electrocution
- Gas Explosion
- Entrapment
- Struck by equipment
- Suffocation

### Hazard Controls

Before any work is performed and before any employees enter the excavation, a number of items must be checked and insured:

- Before any excavation, underground installations must be determined. This can be accomplished by either contacting the local utility companies or the local "**one-call**" center for the area. All underground utility locations must be documented on the proper forms. All overhead hazards (**surface encumbrances**) that create a hazard to employees must be removed or supported to eliminate the hazard.
- If the excavation is to be over 20 feet deep, it must be designed by a registered professional engineer who is registered in the state where the work will be performed.
- Adequate protective systems will be utilized to protect employees. This can be accomplished through sloping, shoring, or shielding.
- The worksite must be analyzed in order to design adequate protection systems and prevent cave-ins. There must also be an excavation safety plan developed to protect employees.
- Workers must be supplied with, and wear, any personal protective equipment deemed necessary to assure their protection.
- All spoil piles will be stored a minimum of **two (2) feet** from the sides of the excavation. The spoil pile must not block the safe means of egress.
- If a trench or excavation is 4 feet or deeper, stairways, ramps, or ladders will be used as a safe means of access and egress. For trenches, the employee must not have to travel any more than 25 feet of lateral travel to reach the stairway, ramp, or ladder.
- No employee will work in an excavation where water is accumulating unless adequate measures are used to protect the employees.
- A competent person will inspect all excavations and trenches daily, prior to employee exposure or entry, and after any rainfall, soil change, or any other time needed during the shift. The competent person must take prompt measures to eliminate any and all hazards.
- Excavations and trenches 4 feet or deeper that have the potential for toxic substances or hazardous atmospheres will be tested at least daily. If the atmosphere is inadequate, protective systems will be utilized.
- If work is in or around traffic, employees must be supplied with and wear orange reflective vests. Signs and barricades must be utilized to ensure the safety of employees, vehicular traffic, and pedestrians.





## Excavation Safety Plan

An excavation safety plan is required in written form. This plan is to be developed to the level necessary to insure complete compliance with the OSHA Excavation Safety Standard and state and local safety standards.

### Excavation Safety Plan Factors:

- Utilization of the local one-call system.
- Determination of locations of all underground utilities.
- Consideration of confined space atmosphere potential.
- Proper soil protection systems and personal protective equipment and clothing.
- Determination of soil composition and classification.
- Determination of surface and subsurface water.
- Depth of excavation and length of time it will remain open.
- Proper adherence to all OSHA Standards, this excavation and trenching safety program, and any other coinciding safety programs.

**1. Warning system for mobile equipment, methods to help prevent vehicles and equipment from falling in the trench can be accomplished by providing:**

- A. Barricades.
- B. Hand or mechanical signals.
- C. Stop logs.
- D. Grade away from the excavation.

All equipment with an obstructed rear view is required to have a back-up alarm or an observer when backing {1926.601 (b) (4).}

**2. Hazardous atmospheres, you must limit all exposures to hazardous atmospheres.**

- A. Oxygen deficient is anything less than 19.5% oxygen. Symptoms will include dizziness, increased heart rate or may experience a buzzing in the ears.
- B. Normal is 21% oxygen.
- C. Oxygen enriched atmospheres increase flammability of combustible materials.
- D. Carbon monoxide causes oxygen starvation and can be fatal at a concentration of 1% for one minute. This is equal to 10,000 PPM. The Threshold Limit Value (TLV) is only 50 PPM.
- E. If there is a possibility that a hazardous atmosphere exists or could be reasonably expected to exist, test the atmosphere before the employee enters an excavation. Some areas of concern include; digging near gas lines, sewers, landfills and near areas of high traffic.
- F. Provide respirators or ventilation when needed. All personnel must be fit tested before wearing a respirator and all personnel must be training how to use ventilation.

**The use of any respirator by employees will require a written respirator program form the employer {1926.103}.**

- A. Ventilate trench if flammable gas exceeds 20% of the lower flammable limit.
- B. Test the atmosphere often--this will ensure that the trench remains safe.
- C. Perform regular maintenance on gas meters. Calibrate and change out filters regularly.

D. Never enter a hazardous atmosphere to rescue an employee unless you have been trained in rescue techniques and have proper rescue equipment. More than half the deaths occur while attempting a rescue.

**3. Emergency rescue equipment must be available when a hazardous atmosphere exists or could be reasonably expected to exist.**

- A. Respirator must be suitable for the exposure. An air supplied or self-contained breathing apparatus is preferable
- B. Harness and lifeline is required when an employee enters bellbottom piers and other deep confined spaces. The lifeline must be attended at all times.

**Employees entering confined spaces must be trained. {1926.21 (b) (6) I}  
Specific requirements for welding in confined spaces {1926.352 (g) and 1926.653 (b)}.**

**4. Protection from hazards associated with water accumulation is necessary to prevent cave-ins.**

- A. Methods for controlling accumulated water vary with each situation.
- B. Employees are not permitted to work in trenches where water accumulation exists.
- C. Special support system or shield systems may be used to protect employees from cave-ins.
- D. Water removal equipment may be used and must be monitored by a competent person to prevent water accumulation.
- E. Safety harness and lifeline may be used to protect employees.
- F. Surface water must be diverted and controlled.
- G. Trench must be inspected after rain.

**5. Stability of adjacent structures to protect employees from cave-ins.**

- A. Support systems such as shoring, bracing, or underpinning must be used to support structures that may be unstable due to excavation operations.
- B. Excavation below the base or footing of a foundation or wall is not permitted unless:
  - i. **Support system is provided to ensure the stability of the structure.**
  - ii. **The excavation is in stable rock.**
  - iii. **A Registered Professional Engineer approves the operation.**
- C. Support systems must be provided for sidewalks, pavements and other structures that may be affected by the excavation operations.

**6. Protection of employees from loose rock or soil.**

- A. Employees must be protected from being struck by materials falling or rolling from the edge and the face of the trench.
- B. Spoils and equipment must be set back at least 2 feet from the edge of the trench and/or a retaining device must be installed.

7. Fall protection is required for walkways and bridges over trenches. Other fall protection may also be required.

8. Remotely located excavations shall be backfilled, covered, or barricaded (for example wells, pits, shafts, etc.)

***Inspections must be made:***

- A. Daily prior to starting work
- B. As needed throughout the shift by a competent person.
- C. After every rainstorm.
- D. After other hazard increasing occurrence (snowstorm, windstorm, thaw, earthquake, etc.).
- E. Inspect the trench for indications of possible cave-ins (fissures, tension cracks, sloughing, undercutting, water seepage, bulging at the bottom).
- F. Inspect adjacent areas (spoil piles, structures).
- G. To protective systems and their components (uprights, wales sheeting, shields hydraulics) before and after use.
- H. Check for indications of a hazardous or potentially hazardous atmosphere.
- I. Test the atmosphere if a hazard could reasonably be expected to exist.



Major OSHA Violation. Do not operate equipment in unprotected trenches. This guy is trying hard to get to Heaven before his time is up.

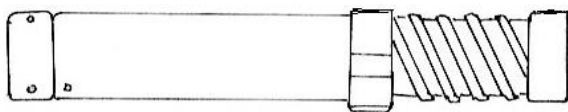

PNEUMATIC / HYDRAULIC JACKS

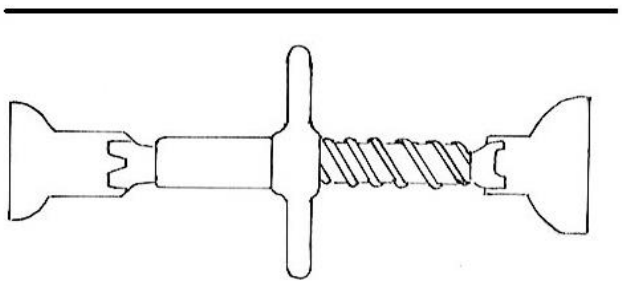
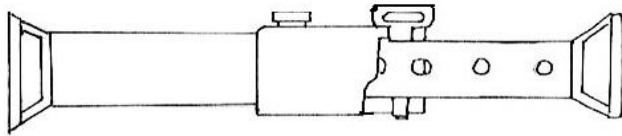

SCREW JACK

UPRIGHT SHEETING

WALE

SCREW JACK

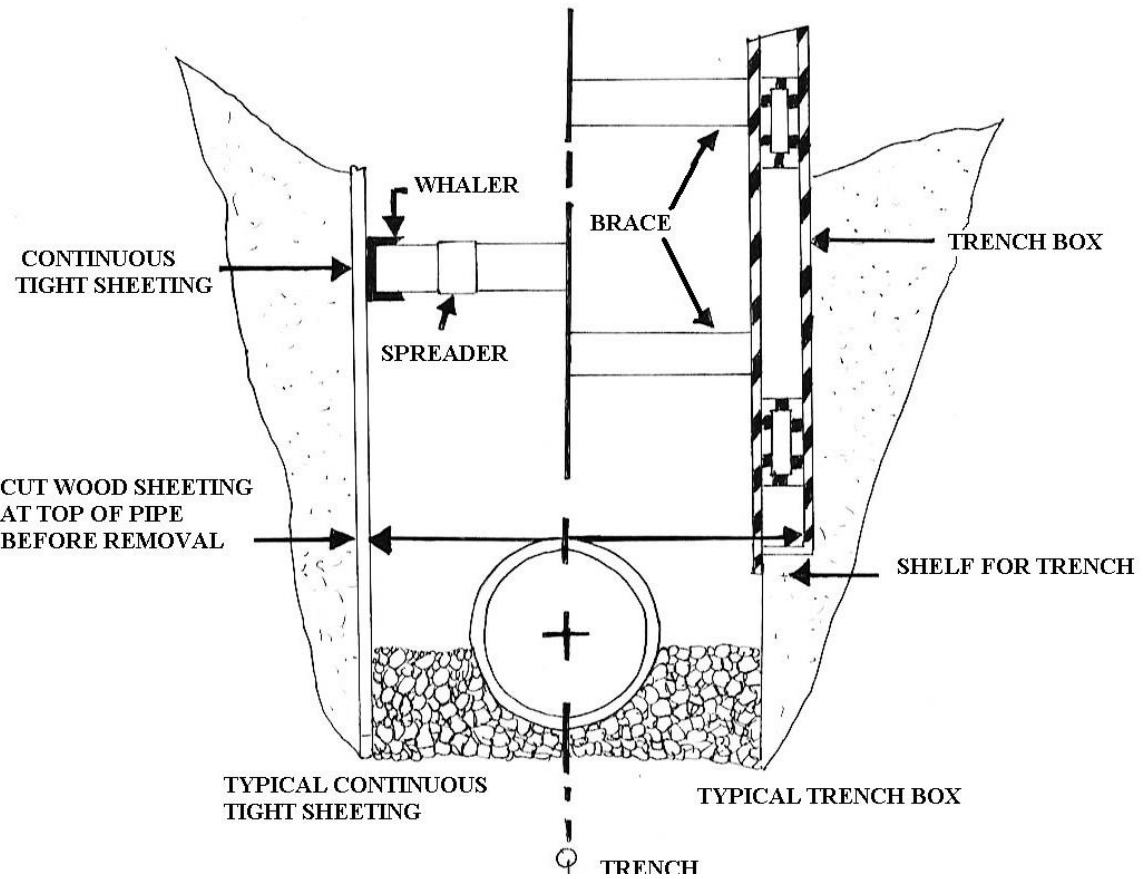
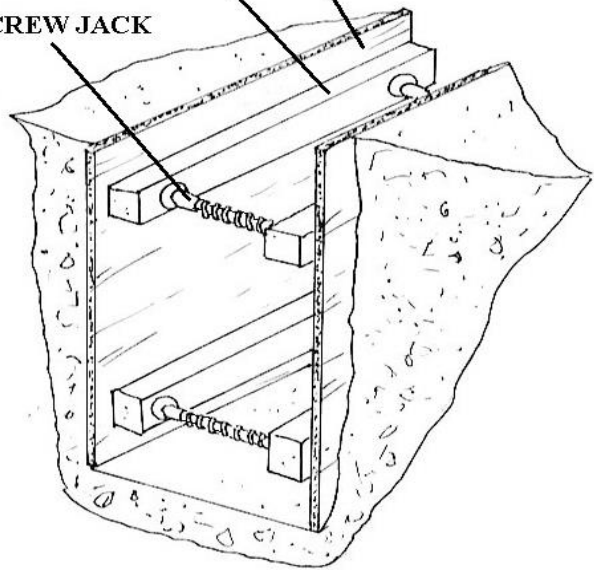

## Soil Classification and Identification

The OSHA Standards define soil classifications within the Simplified Soil Classification Systems, which consist of four categories: Stable rock, Type A, Type B, and Type C. Stability is greatest in stable rock and decreases through Type A and B to Type C, which is the least stable. Appendix A of the standard provides soil mechanics terms and types of field tests used to determine soil classifications. Stable rock is defined as natural solid mineral matter that can be excavated with vertical sides and remain intact while exposed.

### **Type A soil is defined as:**

- Cohesive soils with an unconfined compressive strength of 1.5 tons per square foot (**TSF**) or greater.
- Cemented soils like caliche and hardpan are considered Type A.

### **Soil is NOT Type A if:**

- It is fissured.
- The soil is subject to vibration from heavy traffic, pile driving or similar effects.
- The soil has been previously disturbed.
- The material is subject to other factors that would require it to be classified as a less stable material.
- The exclusions for Type A most generally eliminate it from most construction situations.

### **Type B soil is defined as:**

- Cohesive soil with an unconfined compressive strength greater than .5 TSF, but less than 1.5 TSF.
- Granular cohesion-less soil including angular gravel, silt, silt loam, and sandy loam.
- The soil has been previously disturbed except that soil classified as Type C soil.
- Soil that meets the unconfined compressive strength requirements of Type A soil, but is fissured or subject to vibration.
- Dry rock that is unstable.

### **Type C soil is defined as:**

- Cohesive soil with an unconfined compressive strength of .5 TSF or less.
- Granular soils including gravel, sand and loamy sand.
- Submerged soil or soil from which water is freely seeping.
- Submerged rock that is not stable.



## Soil Test & Identification

The competent person will classify the soil type in accordance with the definitions in Appendix A based on at least one visual and one manual analysis. These tests should be run on freshly excavated samples from the excavation and are designed to determine stability based on a number of criteria: the cohesiveness, the presence of fissures, the presence and amount of water, the unconfined compressive strength, and the duration of exposure, undermining, and the presence of layering, prior excavation and vibration.

The cohesion tests are based on methods to determine the presence of clay. Clay, silt, and sand are size classifications, with clay being the smallest sized particles, silt intermediate and sand the largest.

Clay minerals exhibit good cohesion and plasticity (can be molded). Sand exhibits no elasticity and virtually no cohesion unless surface wetting is present. The degree of cohesiveness and plasticity depend on the amounts of all three types and water.

When examining the soil, three questions must be asked: Is the sample granular or cohesive? Is it fissured or non-fissured? What is the unconfined compressive strength measured in TSF?

The competent person will perform several tests of the excavation to obtain consistent, supporting data along its depth and length. The soil is subject to change several times within the scope of an excavation and the moisture content will vary with weather and job conditions. The competent person must also determine the level of protection based on what conditions exist at the time of the test, and allow for changing conditions.



Ribbon Soil Test



## Sloping

### MAXIMUM ALLOWABLE SLOPES

SOIL TYPE	SLOPE (H:V)	ANGLE( ° )
Stable Rock	Vertical	90°
Type A	3/4 : 1	53°
Type B	1 : 1	45°
Type C	1/2 : 1	34°

**MAXIMUM ALLOWABLE SLOPE** means the steepest incline of an excavation face that is acceptable for the most favorable site conditions as protection against cave-ins and is expressed as the ratio of horizontal distance to vertical rise (H:V).

The tables and configurations within Appendix B may be used to a maximum depth of twenty (20') feet deep. Jobs more than twenty (20') feet in depth require the design of a sloping plan by a registered professional engineer (RPE). If configurations are used for depths less than 20 feet other than those found in Appendix B, they must also be designed by a registered professional engineer.

## Shielding

The third method of providing a safe workplace in excavations is shielding. Shielding is different from shoring and sloping in that it does not prevent cave-ins. Instead, it protects the workers in the event of a cave-in. Its function is therefore somewhat similar to that of a bomb shelter.

Shields are simply devices that, when placed in an excavation, have sufficient structural strength to support the force of a cave-in should one occur.

Shields take a number of different shapes and sizes. Most shields consist of two flat, parallel metal walls which are held apart by metal cross braces which are placed at the ends of the "Box" to allow for the installation of pipe within its interior dimensions.



These boxes are used to greatest effect in what is known as "cut and cover" operations where a contractor excavates just enough trench to install the shield, then sets a joint of pipe, then excavates further, then pulls the shield forward to install another joint while the first is being backfilled.

This method is extremely cost effective in that it is fast, safe, requires minimum excavation and minimum open trench. It has become the preferred method of laying pipe in most instances.

While original shields were quite large, smaller shields have gained in popularity with public works maintenance crews and contractors working in shallow excavations because of their ease of use. Recently, round shields, made of corrugated metal have appeared. The sizes, shapes and possibilities for the applications of shields are endless. If they are to be used, however, several points must be borne in mind.

1. Shield construction is not covered by the standard. Users must rely on manufacturers' requirements. For this reason, it is critical that you know your supplier. Reputable manufacturers supply boxes designed by registered professional engineers, and the standard requires that they are certified for their applications. Do not make the mistake of having the neighborhood welder fabricate one. A user must know that their shield is appropriate for the situation.
2. Bent cross braces are not braces, they are hinges. Any bent or deformed structural member must be repaired or replaced according to the manufactures' guidelines.
3. The manufacturer must approve any modification to the shields.
4. Shields must be installed so as to prevent lateral movement in the event of a cave-in.
5. Shields may ride two feet above the bottom of an excavation, provided they are calculated to support the full depth of the excavation and there is no caving under or behind the shield.
6. Workers must enter and leave the shield in a protected manner, such as by ladder within the shield or a properly sloped ramp at the end.
7. Workers may not remain in the shield during its installation, removal or during vertical movement.
8. Do not forget about the open end of the shield if it exposes a wall of the excavation. The wall should be sloped, shored or shielded off to prevent a cave-in from the end.
9. If the excavation is deeper than the shield is tall, attached shields of the correct specifications may be used or the excavation may be sloped back to maximum allowable angle from a point 18 inches below the top of the shield.

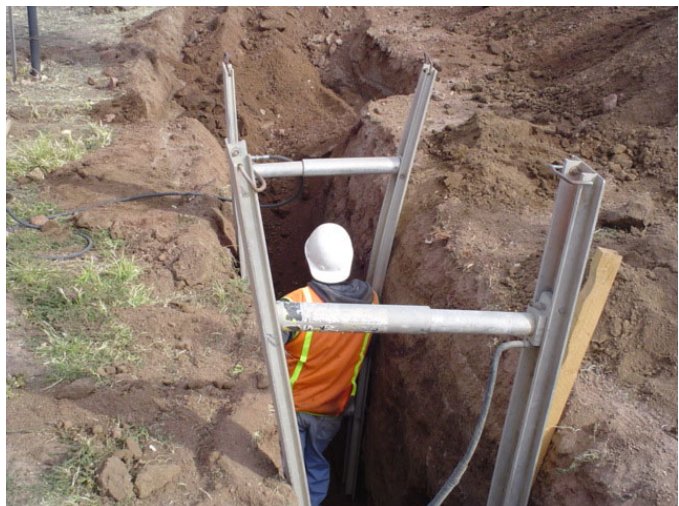

***Complete Rule and further instructions are located in TLC's Competent Person Course.***

## Inspections

Daily inspection of excavations, the adjacent areas and protective systems shall be made by the competent person for evidence of a situation that could result in a cave-in, indications of failure of protective systems, hazardous atmospheres or other hazardous conditions.

- All inspections shall be conducted by the competent person prior to the start of work and as needed throughout the shift.
- Inspections will be made after every rainstorm or any other increasing hazard.
- All documented inspections will be kept on file in the jobsite safety files and forwarded to the Safety Director weekly.
- A copy of the **Daily Excavation Inspection** form is located at the end of this program. The competent person(s) must be trained in accordance with the OSHA Excavation Standard, and all other programs that may apply (examples Hazard Communication, Confined Space, and Respiratory Protection), and must demonstrate a thorough understanding and knowledge of the programs and the hazards associated. All other employees working in and around the excavation must be trained in the recognition of hazards associated with trenching and excavating.





Two unsafe excavation examples: Top, notice the man in a 6 foot deep trench with no ladder or shoring, and the placement of spoil. Bottom photograph, utilities are marked after the excavation has begun, no hard hats, no ladders, no protective system, incorrect spoil placement.



## DAILY EXCAVATION CHECKLIST

Client		Date	
Project Name		Approx. Temp.	
Project Location		Approx. Wind Dir.	
Job Number		Safety Rep	
Excavation Depth & Width		Soil Classification	
Protective System Used			
Activities In Excavation			
Competent Person			

Excavation > 4 feet deep?  Yes  No

**NOTE:** Trenches over 4 feet in depth are considered excavations. Any items marked **NO** on this form **MUST** be remediated prior to any employees entering the excavation.

YES	NO	N/A	DESCRIPTION
<b>GENERAL</b>			
			Employees protected from cave-ins & loose rock/soil that could roll into the excavation
			Spoils, materials & equipment set back at least 2 feet from the edge of the excavation.
			Engineering designs for sheeting &/or manufacturer's data on trench box capabilities on site
			Adequate signs posted and barricades provided
			<b>Training (toolbox meeting) conducted w/ employees prior to entering excavation</b>
<b>UTILITIES</b>			
			Utility company contacted & given 24 hours' notice &/or utilities already located & marked
			Overhead lines located, noted and reviewed with the operator
			Utility locations reviewed with the operator, & precautions taken to ensure contact does not occur
			Utilities crossing the excavation supported, and protected from falling materials
			<b>Underground installations protected, supported or removed when excavation is open</b>
<b>WET CONDITIONS</b>			
			Precautions taken to protect employees from water accumulation (continuous dewatering)
			Surface water or runoff diverted /controlled to prevent accumulation in the excavation
			Inspection made after every rainstorm or other hazard increasing occurrence

HAZARDOUS ATMOSPHERES		
		Air in the excavation tested for oxygen deficiency, combustibles, other contaminants
		Ventilation used in atmospheres that are oxygen rich/deficient &/or contains hazardous substances
		Ventilation provided to keep LEL below 10 %
		Emergency equipment available where hazardous atmospheres could or do exist
		Safety harness and lifeline used
		Supplied air necessary (if yes, contact safety department)
ENTRY & EXIT		
		Exit (i.e. ladder, sloped wall) no further than 25 feet from ANY employee
		Ladders secured and extend 3 feet above the edge of the trench
		Wood ramps constructed of uniform material thickness, cleated together @ the bottom
		Employees protected from cave-ins when entering or exiting the excavation

***Explain how you have secured the site and made it safe to work inside (if possible)***



## One-Call Center or Bluestakes

You are required to locate or call for proper buried utility locations before you dig or excavate. You will usually need a 48-hour notice before you excavate. Please check with your local one-call system.



Red spray marks means - Electricity, Yellow marks-Gas, Blue marks-Water



Orange spray marks means - Telephone & Fiber Optics

## One Call Program

According to federal safety statistics, damage from unauthorized digging is the major cause of natural gas pipeline failures. To prevent excavation damage to all utilities, including pipelines, all 50 states have instituted "One Call" Programs. The programs provide telephone numbers for excavation contractors to call before excavation begins.

The one-call operator will notify a pipeline company of any planned excavation in the vicinity of its pipeline so that the company can flag the location of the pipeline and assign personnel to be present during excavation, if necessary.

In a related effort, a joint government-industry team has developed a public education program entitled "*Dig Safely*". The team involved representatives from the U.S. Department of Transportation, gas and liquid pipeline companies, distribution companies, excavators, the insurance industry, one-call systems and the telecommunications industry. This campaign provides information to the general public concerning underground utilities and the danger of unknowingly digging into buried lines and cables.

The program has posters, brochures, and other printed materials available for use by interested organizations. For more information, contact [www.digsafely.com](http://www.digsafely.com).



Telephone Cables, difficult to dig around. It's almost as bad as electric lines.



## One-Call Center, Underground Utilities

One Call Centers were established as a one-call notification system by underground facility owners to assist excavators with statutory requirements to notify underground facility owners prior to excavation. This damage prevention service is provided free of charge to any individual or company planning to excavate. By participating in the program and getting underground facilities located, you can:

- **Comply with Federal Law**
- **Avoid Injuries**
- **Prevent costly damages and interruptions of facility services**
- **Save time and money**
- **Avoid hazards**
- **Eliminate construction delays**

### Color Codes for marking underground utility lines.

Red..... Electric Power  
Yellow ..... Gas-Oil- Product Lines  
Orange..... Communication, Cable television  
Blue..... Water systems, slurry pipelines  
Green..... Sanitary sewer system  
Pink..... Temporary survey markings

#### ***Example of a One-Call Center's Rules***

Excavations: determining location of underground facilities; providing information; excavator marking; on-site representative; validity period of markings.

- A. A person shall not make or begin any excavation in any public street, alley, right-of-way dedicated to the public use or utility easement or on any express or implied private property utility easement without first determining whether underground facilities will be encountered, and if so where they are located from each and every public utility, municipal corporation or other person having the right to bury such underground facilities within the public street, alley, right-of-way or utility easement and taking measures for control of the facilities in a careful and prudent manner.
- B. Every public utility, municipal corporation or other person having the right to bury underground facilities shall file with the corporation commission the job title, address and telephone number of the person or persons from whom the necessary information may be obtained. Such person or persons shall be readily available during established business hours. The information on file shall also include the name, address and telephone number of each one-call notification center to which the owner of the facility belongs. Upon receipt of inquiry or notice from the excavator, the owner of the facility shall respond as promptly as practical, but in no event later than two days, by marking such facility with stakes, paint or in some customary manner. No person shall begin

excavating before the location and marking are complete or the excavator is notified that marking is unnecessary.

- C. On a timely request by the owner of a facility, the excavator shall mark the boundaries of the location requested to be excavated in accordance with a color code designated by the commission or by applicable custom or standard in the industry. A request under this subsection for excavator marking does not alter any other requirement of this section.
  
- D. In performing the marking required by subsection B of this section, the owner of an underground facility installed after December 31, 1988 in a public street, alley or right-of-way dedicated to public use, but not including any express or implied private property utility easement, shall locate the facility by referring to installation records of the facility and utilizing one of the following methods:
  - 1. Vertical line or facility markers.
  - 2. Locator strip or locator wire.
  - 3. Signs or permanent markers.
  - 4. Electronic or magnetic location or tracing techniques.
  - 5. Electronic or magnetic sensors or markers.
  - 6. Metal sensors or sensing techniques.
  - 7. Sonar techniques.
  - 8. Underground electrical or radio transmitters.
  - 9. Manual location techniques, including pot-holing.
  - 10. Surface extensions of underground facilities.
  - 11. Any other surface or subsurface location technique at least as accurate as the other marking methods in this subsection not prohibited by the commission or by federal or state law.
  
- E. For an underground facility other than one installed after December 31, 1988, in a public street, alley or right-of-way dedicated to public use, in performing the marking required by subsection B of this section, the owner may refer to installation or other records relating to the facility to assist in locating the facility and shall locate the facility utilizing one of the methods listed under subsection D of this section.

If an underground facility owner is unable to complete the location and marking within the time period provided by subsection B of this section, the facility owner shall satisfy the requirements of this section by proving prompt notice of these facts to the excavator.

Assigning one or more representatives to be present on the excavation site at all pertinent times as requested by the excavator to provide facility location services until the facilities have been located and marked.

The underground facility owner shall bear all of its costs associated with assigning representatives. If representatives are assigned under this subsection, the excavator is not responsible or liable for damage or repair of the owner's underground facility while acting under the direction of an assigned representative of the owner, unless the damage or need for repair was caused by the excavator's negligence.

## Natural Gas Safety

That familiar blue flame that plays such an important role in our lives should, like other sources of energy, be treated with respect. Following a few simple guidelines can help ensure that you can safely enjoy all the benefits natural gas has to offer.

Natural gas is colorless and invisible. When it burns it should appear as a clear, blue flame. Because natural gas has no odor, a special chemical called mercaptan is added to make it easy to detect gas leaks from pipes or appliances. This odor is commonly described as a rotten-egg smell.

Natural gas is clean-burning. When burned completely, it produces only water vapor and carbon dioxide, just as you do when you breathe. Natural gas is such a safe and dependable fuel that it's easy to take for granted. But please, never take safety for granted. As with any source of energy, you should follow certain safety measures when using natural gas.

When it's taken from the ground, natural gas is tasteless, colorless and odorless. To make it easier to detect, a harmless but strong-smelling odorant is added, Ethyl Mercaptan. If you ever smell this "**rotten egg-like**" odor, it may mean there is a gas leak.

### WHAT TO DO IF YOU SMELL GAS:

- Do not smoke. Do not use lighters or matches.
- Do not turn on/off any switches or appliances.
- Our personnel are available 24 hours a day to respond to any emergency call.

### Carbon Monoxide

Carbon monoxide is produced when burning any fuel incompletely, such as charcoal, gasoline or wood. Carbon monoxide is highly poisonous and it has no odor, taste or color. If natural gas equipment is not maintained, adjusted and operated properly, it could produce carbon monoxide.

Your natural gas appliances should produce a clear, steady blue flame. If your gas appliances exhibit an unusual behavior or produce a yellowish-color flame, that may be a warning sign that your appliance is producing carbon monoxide.

A licensed professional should inspect appliances annually to insure safe operation. An inspection will accomplish the following:

- Make sure the appliance is installed properly and that it is in good working condition.
- Ensure that there is enough fresh air circulating for the fuel to burn properly.
- Check that vents are in good condition and are not blocked with debris.

### Other helpful tips:

- The area surrounding your gas appliances should be clear from clutter or trash.
- Carbon monoxide detectors may be helpful in your home or business. But remember, a carbon monoxide detector should never be substituted for using equipment safely - which includes having your heating and cooking equipment inspected once a year by a trained professional.



OSHA's General Industry Regulation, §1910.146 Permit-required confined spaces, contains requirements for practices and procedures to protect employees in general industry from the hazards of entry into permit-required confined spaces. This regulation does not apply to construction.

OSHA's Construction Safety and Health Regulations Part 1926 do not contain a permit-required confined space regulation. Subpart C, §1926.21 Safety training and education specifies training for personnel who are required to enter confined spaces and defines a "*confined or enclosed space*."

## Lockout - Tagout Training Sub-Section (LOTO) Lockout and Tagout

### Purpose

Control of Hazardous energy is the purpose of the Lockout- Tagout Policy. This policy establishes the requirements for isolation of both kinetic and potential electrical, chemical, thermal, hydraulic and pneumatic and gravitational energy prior to equipment repair, adjustment or removal. The Lockout -Tagout Electrical Safety Policy is part of your overall safety program. If you do not understand this policy, it's your responsibly to ask your supervisor to have this policy explained to you.

**Reference:** OSHA Standard 29 CFR 1910. 147, the control of hazardous energy.

### Definitions

**Authorized (Qualified) Employees** are the only ones certified to lock and tag-out equipment or machinery. Whether an employee is considered to be qualified will depend upon various circumstances in the workplace. It is likely for an individual to be considered "qualified" with regard to certain equipment in the workplace, but "*unqualified*" as to other equipment.

An employee who is undergoing on-the-job training and in the course of such training, has demonstrated an ability to perform duties safely at his or her level of training and who is under the direct supervision of a qualified person, is considered to be "qualified" for the performance of those duties.

**Affected Employees** are those employees who operate machinery or equipment upon which lockout or tagging out is required under this program. Training of these individuals will be less stringent in that it will include the purpose and use of the lockout procedures.

**Other Employees** are identified as those that do not fall into the authorized, affected or qualified employee category. Essentially, it will include all other employees. These employees will be provided instruction in what the program is and not to touch any machine or equipment when they see that it has been locked or tagged out.

### Training

#### Authorized Employees Training Example

All maintenance employees and Department Supervisors will be trained to use the Lock and Tagout Procedures. The training will be conducted by the Supervisor or Safety Coordinator at time of initial hire. Retraining shall be held at least annually. The training will consist of the following:

- Review of General Procedures.
- Review of Specific Procedures for machinery, equipment and processes.
- Location and use of Specific Procedures.
- Procedures when questions arise.



### **Affected Employee Training**

- Only trained and authorized employees will repair, replace or adjust machinery, equipment or processes.
- Affected employees may not remove Locks, locking devices or tags from machinery, equipment or circuits.
- Purpose and use of the lockout procedures.



### **Other Employee Training**

- Only trained and authorized employees will repair, replace or adjust machinery or Equipment.
- Other employees may not remove Locks, locking devices or tags from machinery, equipment or circuits.

### **Preparation for Lock and Tagout Procedures *Example***

A Lockout - Tagout survey will be conducted to locate and identify all energy sources to verify which switches or valves supply energy to machinery and equipment. Dual or redundant controls will need to be removed.

A Tagout Schedule will be developed for each piece of equipment and machinery. This schedule describes the energy sources, location of disconnects, type of disconnect, special hazards and special safety procedures. The schedule will be reviewed each time to ensure employees properly lock and tag out equipment and machinery.

If a Tagout Schedule does not exist for a particular piece of equipment, machinery and process, one must be developed prior to conducting a Lockout - Tagout. As repairs and/or renovations of existing electrical systems are made, standardized controls will be used. It is your departmental supervisor's responsibility to ensure that a schedule is made.

### **Routine Maintenance & Machine Adjustments**

Lock and Tag out procedures are not required if equipment must be operating for proper adjustment. This rare exception may be used only by trained and authorized employees when specific procedures have been developed to safely avoid hazards with proper training. All consideration shall be made to prevent the need for an employee to break the plane of a normally guarded area of the equipment by use of tools and other devices.

### **Standard Operating Procedure (SOP): General Lock and Tag out Procedures**

Before working on, repairing, adjusting or replacing machinery and equipment, the following procedures will be utilized to place the machinery and equipment in a neutral or zero mechanical state.

## **Preparation for Shutdown *Example***

Before authorized or affected employees turn off a machine or piece of equipment, the authorized employee will have knowledge of the type and magnitude of the energy, the hazards of the energy to be controlled, and the means to control the energy. Notify all affected employees that the machinery, equipment or process will be out of service.

### **Machine or Equipment Shutdown.**

The machine or equipment will be turned off or shut down using the specific procedures for that specific machine. An orderly shutdown will be utilized to avoid any additional or increased hazards to employees as a result of equipment de-energization.

If the machinery, equipment or process is in operation, follow normal stopping procedures (depress stop button, open toggle switch, etc.). Move switch or panel arms to "Off" or "Open" positions and close all valves or other energy isolating devices so that the energy source(s) is disconnected or isolated from the machinery or equipment.

### **Machine or Equipment Isolation.**

All energy control devices that are needed to control the energy to the machine or equipment will be physically located and operated in such a manner as to isolate the machine or equipment from the energy source.

### **Lockout or Tagout Device Application.**

Lockout or tagout devices will be affixed to energy isolating devices by authorized employees.

Lockout devices will be affixed in a manner that will hold the energy isolating devices from the "safe" or "off" position.

Where tagout devices are used, they will be affixed in such a manner that will clearly state that the operation or the movement of energy isolating devices from the "safe" or "off" positions is prohibited.

The tagout devices will be attached to the same point a lock would be attached. If the tag cannot be affixed at that point, the tag will be located as close as possible to the device in a position that will be immediately obvious to anyone attempting to operate the device.

Lock and tag out all energy devices by use of hasps, chains and valve covers with assigned individual locks.

### **Stored Energy**

Following the application of the lockout or tagout devices to the energy isolating devices, all potential or residual energy will be relieved, disconnected, restrained, and otherwise rendered safe.

Where the re-accumulation of stored energy to a hazardous energy level is possible, verification of isolation will be continued until the maintenance or servicing is complete.

Release stored energy (capacitors, springs, elevated members, rotating fly wheels, and hydraulic/air/gas/steam systems) must be relieved or restrained by grounding, repositioning, blocking and/or bleeding the system.

### **Verification of Isolation**

Prior to starting work on machines or equipment that have been locked or tagged out, the authorized employees will verify that isolation or de-energization of the machine or equipment have been accomplished.

After assuring that no employee will be placed in danger, test all lock and tag outs by following the normal start up procedures (depress start button, etc.).

**Caution:** After Test, place controls in neutral position.

### **Extended Lockout - Tagout**

Should the shift change before the machinery or equipment can be restored to service, the lock and tag out must remain. If the task is reassigned to the next shift, those employees must lock and tag out before the previous shift may remove their lock and tag.

### **SOP: Release from LOCKOUT/TAGOUT *Example***

Before lockout or tagout devices are removed and the energy restored to the machine or equipment, the following actions will be taken:

1. The work area will be thoroughly inspected to ensure that nonessential items have been removed and that machine or equipment components are operational.
2. The work area will be checked to ensure that all employees have been safely positioned or removed. Before the lockout or tagout devices are removed, the affected employees will be notified that the lockout or tagout devices are being removed.
3. Each lockout or tagout device will be removed from each energy-isolating device by the employee who applied the device.

### **SOP: LOTO Procedure for Electrical Plug-Type Equipment *Example***

This procedure covers all Electrical Plug-Type Equipment such as battery chargers, some product pumps, office equipment, powered hand tools, powered bench tools, lathes, fans, etc.

When working on, repairing, or adjusting the above equipment, the following procedures must be utilized to prevent accidental or sudden startup:

1. Unplug electrical equipment from wall socket or in-line socket.
2. Attach "**Do Not Operate**" Tag and Plug Box & Lock on end of power cord.  
An exception is granted to not lock & tag the plug if the cord & plug remain in the exclusive control of the Employee working on, adjusting or inspecting the equipment.
3. Test equipment to assure power source has been removed by depressing the "Start" or "On" Switch.
4. Perform required operations.
5. Replace all guards removed.
6. Remove Lock & Plug Box and Tag.
7. Inspect power cord and socket before plugging equipment into power source. Any defects must be repaired before placing the equipment back in service.

**NOTE:** Occasionally used equipment may be unplugged from power source when not in use.



### **SOP: LOTO Procedures Involving More Than One Employee**

In the preceding SOPs, if more than one employee is assigned to a task requiring a lock and tag out, each must place his/her own lock and tag on the energy isolating device(s).

### **SOP: Management Removal of Lock and Tag Out**

Only the employee that locks and tags out machinery, equipment or processes may remove his/her lock and tag. However, the employee should leave the facility before removing his/her lock and tag, and the supervisor may remove the lock and tag. The supervisor must be assured that all tools have been removed, all guards have been replaced and all employees are free from any hazard before the lock and tag are removed and the machinery, equipment or process are returned to service. Notification of the employee who placed the lock is required prior to lock removal.

### **Contractors**

Contractors working on our property and equipment must use this Lockout-Tagout procedure while servicing or maintaining equipment, machinery or processes.

### **Lockout - Tag out Safety Equipment**

The employer will provide all Lockout-Tagout safety equipment and training to any employee that may need or work with electricity or powered equipment. Your supervisor will be able to provide any assistance or equipment.

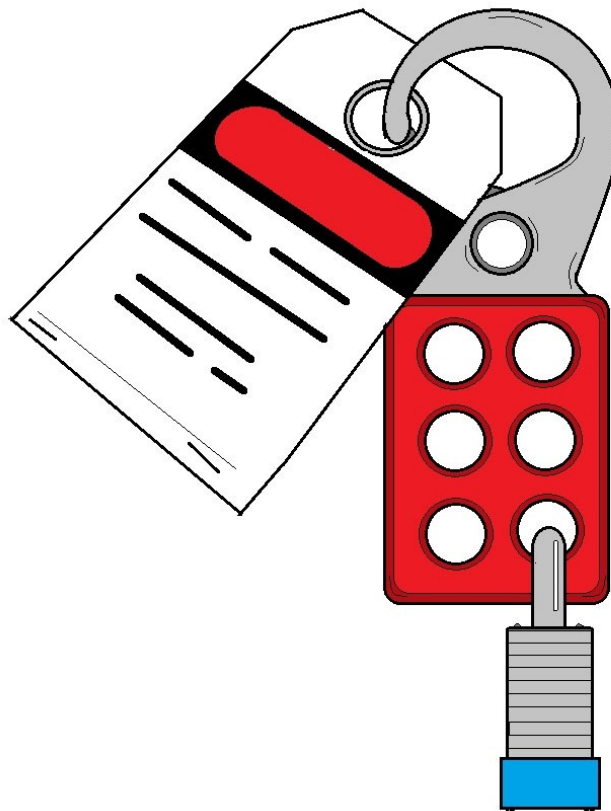

**USE LOCK-OUT TAGS, LOCKS AND HASPS TO DENERGIZE EQUIPMENT TO  
AVOID ACCIDENTAL START-UP AND PREVENT INJURIES OR DEATH**



## Ladder Safety Sub-Section

### Purpose

Ladders present unique opportunities for unsafe acts and unsafe conditions. Employees who use ladders must be trained in proper selection, inspection, use and storage. Improper use of ladders has caused a large percentage of accidents in the workplace. Use caution on ladders.

**OSHA reference:** (29 CFR 1910.25, 1910.26, and 1910.27).

### Ladder Hazards

Falls from ladders can result in broken bones and death. Ladder safety is a lifesaving program at our company.

### Hazards include:

- Ladders with missing or broken parts.
- Using a ladder with too low a weight rating.
- Using a ladder that is too short for the intended purpose.
- Using metal ladders near electrical wires.
- Using ladders as a working platform.
- Objects falling from ladders.

### Ladder Inspection

Inspect ladders before each use.

- All rungs and steps are free of oil, grease, dirt, etc.
- All fittings are tight.
- Spreaders or other locking devices are in place.
- Non-skid safety feet are in place.
- No structural defects, all support braces intact.

Do not use broken ladders. Most ladders cannot be repaired to manufacturer specifications. Throw away all broken ladders.



### Ladder Storage

Store ladders on sturdy hooks in areas where they cannot be damaged. Store to prevent warping or sagging. Do not hang anything on ladders that are in a stored condition.

### Ladder Ratings & Limits

#### Ladder weight ratings

- I-A 300 pounds (heavy duty)
- I 250 pounds (heavy duty)
- II 225 pounds (medium duty)
- III 200 pounds (light duty).

### Limits on ladder length.

- A stepladder should be no more than 20 feet high.
- A one-section ladder should be no more than 30 feet.
- An extension ladder can go to 60 feet, but the sections must overlap.

### Ladder Setup

The following procedure must be followed to prevent ladder accidents:

- ✓ Place ladder on a clean, slip-free level surface.
- ✓ Extend the ladder to have about 4 feet above the top support or work area.
- ✓ Anchor the top and bottom of the ladder.
- ✓ Place the ladder base 1/4 the height of the ladder from the wall when using an extension ladder.
- ✓ Never allow more than one person on a ladder.
- ✓ Use carriers and tool belts to carry objects up a ladder.
- ✓ Do not lean out from the ladder in any direction.
- ✓ If you have a fear of heights - don't climb a ladder.
- ✓ Do not allow others to work under a ladder in use.

### Ladder Maintenance

- ✓ Keep ladders clean.
- ✓ Never replace broken parts unless provided by the original manufacturer.
- ✓ Do not attempt to repair broken side rails.



We have a ladder in an excavation, but no protective system in place or hard hat.

## SAFETY SECTION GLOSSARY

**Barricades:** Visible warning barriers that keep vehicles and pedestrians from entering a construction site.

**Braces:** Devices that hold or fasten two or more parts together or in place. Braces are diagonal or horizontal. They may be made of wood or metal.

**Bracing System:** A system of braces which applies pressure against trench walls to stabilize them. A bracing system is part of a trench shoring system used to prevent trench walls from collapsing.

**Benching:** A method of cutting back the sides of a trench into horizontal steps to prevent cave-ins.

**Bulge:** An outward swelling in the soil of a trench; may be a warning sign of trench failure.

**Buried Structures:** Manholes, junction boxes or catch basins beneath the ground or any other installations that may be encountered during trenching.

**Clay:** Fine-grained natural soil that is plastic when moist and hard and brittle when dry. Clay is made up of particles smaller than .0002 millimeters.

**Clumps:** Heavy lumps or thick groupings of soil.

**Cohesion:** The relative ability to clump together, the force holding two like substances together.

**Cohesive:** When a soil has grains that hold together and clump well.

**Competent Person:** One who is capable of identifying existing, and predictable hazards in the surroundings, or working conditions which are unsanitary, hazardous or dangerous to employees. They have the authorization to take prompt corrective measures to eliminate hazards. The Competent Person is trained and knowledgeable about soil analysis and the use of protective systems.

**Confined Space:** Has limited or restricted means of entry or exit, is large enough for an employee to enter and perform assigned work, and is not designed for continuous occupancy by the employee. These spaces may include, but are not limited to, underground vaults, tanks, storage bins, pits, and diked areas, vessels, and silos.

**Diversion Ditches:** A ditch cut around the work site to keep water from entering the trench.

**Drainage System:** Pumps, pipe or channel used to drain off rain or groundwater from inside the trench.

**Excavation:** Any man-made cut, cavity trench or depression in an earth surface, formed by earth removal.

**Fissure:** A long narrow opening or crack in the rock or soil. Fissures are often a sign of trench wall failure.

**Grain:** Particles that once were large rocks, but have been broken down through time and the effects of weathering. The size of the grain of a soil determines the stability and cohesiveness of a soil. The larger the grain is, the more unstable the soil is.

**Gravel:** A loose mixture of pebbles and rock fragments, which is coarser than sand.

**Hardpan:** A layer of hard subsoil or clay that does not allow water in. Hardpan is classified as a Type A soil.

**Heaving:** The swelling of a soil.

**Jacks:** Jacks are braces or supports within a shoring system. They are placed against beams to resist the pressure of the earth.

**Loamy Sand:** Soil composed of a mixture of sand, clay and silt, with more sand grains than clay or silt. It is classified as a Type C soil.

**Manufacturer's Tabulated Data:** Tables and charts approved by a registered professional engineer and used to design and construct a protective system.

**Permit Required Confined Space:** Meets the definition of a confined space and has one or more of these characteristics: (1) contains or has potential to contain a hazardous atmosphere, (2) contains a material that has the potential for engulfing an entrant, (3) has an internal configuration that might cause an entrant to be trapped or asphyxiated by inwardly converging walls or by a floor that slopes downward and tapers to a smaller cross section, and/or (4) contains any other recognized serious safety or health hazards.

**Personal Protective Equipment:** Safety goggles and glasses, reflective clothing, work gloves, hard hat, safety shoes, rubber boots, earplugs or protectors, face shield and face mask or respirator.

**Registered Professional Engineer:** A person who is registered as a professional engineer in the state where the work is to be performed.

**Sand:** A type C soil with small, loose grains of disintegrated rock.

**Sandy Loam:** Granular soil with enough silt and clay to make it slightly cohesive

**Saturation:** The process of a soil being filled to capacity with moisture.

**Shear:** A phenomenon which happens when a trench wall is subjected to stress. Fissured cracks widen until a portion of the trench wall breaks off and slides into the trench.

**Sheeting:** Durable sheets of metal or wood, which are held firmly against a trench wall to prevent it from caving-in. Sheeting is a component of a trench shoring system.

**Shielding:** A device which provides adequate protection from falling or collapsing earth loads. The trench box is a common form of shielding.

**Shoring:** Main method of stabilizing and supporting a trench wall to prevent cave-ins. It consists of uprights, stingers and braces.

**Silt:** A soil which contains fine particles and is very smooth.

**Silty Clay:** A plastic soil that will appear rough or broken when rubbed over the thumb and finger.

**Sloping:** The process of cutting back the sides of a trench to avoid a cave-in.

**Sloughing:** When loose soil begins to run in from the lower part of the wall into the excavation. It is the first step to a wall collapse.

**Soil Type:** A system of classifying soils and rock deposits. Soil must be classified by a qualified person as: Stable rock, Type-A, Type-B, Type-C.

**Spall:** When a soil begins to crack or flake due to pressure, or from moisture from within the trench.

**Spoil Pile/Spoilage:** Rock waste, banks and dumps from the excavation.

**Supports:** Part of a shoring system which helps to bear the weight of braces and other parts of the shoring system.

**Trench Box:** A prefabricated moveable box usually constructed of metal plates welded to a heavy steel frame. The box is moved along as work progresses. It is able to withstand the forces imposed on it by a cave-in and thereby protects trench workers.

**Type-A Soil:** The most stable and cohesive type of soil while working at a trench site. Examples are clay, silty clay and hardpan.

**Type-B Soil:** Type-B soil is next to the most stable soil. Silt, silt loam, sandy loam, medium clay and unstable rock would be good examples of Type-B soils.

**Type-C Soil:** The least stable type of soil. Examples of Type-C soils are gravel, loamy sand, soft clay, submerged silt and heavy unstable rock.

**Unconfined Compressive Strength:** Through a variety of tests, a soil's strength is found. The unconfined compressive strength is the soil's measure of bearing capacity and shearing resistance. Measured as the amount of weight per square foot needed to collapse a soil sample.

**Uprights:** Vertical members of a trench shoring system placed in contact with the earth. These members usually are not placed in direct contact with one another.

**Vibration:** When a soil or excavation site trembles and shakes rapidly due to forces such as loud noises or heavy equipment or traffic.

**Voids:** Voids are empty spaces between particles of rocks.

**Wales:** Wales are parts of a shoring system. They are positioned horizontally and help to brace vertical beams and supports. Wales can be fastened to studs with nails, clips or brackets.

**Wall Stability:** The relative strength and capacity of walls of a trench.



Provide at least one attendant outside the permit space into which entry is authorized for the duration of entry operations;

**NOTE:** Attendants may be assigned to monitor more than one permit space provided the duties described in paragraph (i) of this section can be effectively performed for each permit space that is monitored. Likewise, attendants may be stationed at any location outside the permit space to be monitored as long as the duties described in paragraph (i) of this section can be effectively performed for each permit space that is monitored.



## Post Quiz

1. A competent person is one who is capable of \_\_\_\_\_ existing hazards in the surroundings or working conditions which are unsanitary, hazardous, or dangerous to employees; and who has authorization to take prompt corrective measures to eliminate them.
2. In order to be a "Competent Person" for the purpose of this standard, one must have specific training in and be \_\_\_\_\_ about soils analysis, the use of protective systems and the requirements of 29 CFR Part 1926.650-652 Subpart P.

### Competent Person Duties

3. \_\_\_\_\_ daily inspections of the protective equipment, trench conditions, safety equipment and adjacent areas.
4. \_\_\_\_\_ shall be made prior to the start of work and as needed throughout the shift.
5. \_\_\_\_\_ shall be made after every rainstorm or other hazard occurrence.
6. \_\_\_\_\_ of emergency contact methods, telephone or radio dispatch.
7. \_\_\_\_\_ the appropriate protection system to be used.
8. \_\_\_\_\_ on-site records of inspections and protective systems used.
9. \_\_\_\_\_ current First Aid and CPR certifications. Maintain current confined space certification training.
10. During excavation work, a competent person shall be on the job site at all times when personnel are working within or around the excavation. This is necessary in order to \_\_\_\_\_ soil conditions, equipment and protection systems employed.
11. The estimated locations of utility installations, such as sewer, telephone, fuel, electric, water lines, or any other underground installation that reasonably may be expected to be encountered during excavation work, shall be \_\_\_\_\_ prior to opening an excavation.

12. Adequate \_\_\_\_\_ shall be taken to protect employees working in excavations, against the hazards posed by water accumulation.

13. \_\_\_\_\_ shall be protected from excavated or other materials, or equipment, that could pose a hazard by falling or rolling into excavations.

14. Protection shall be provided by placing and keeping such material or equipment at least two (2') feet from the edge of \_\_\_\_\_.

15. A stairway, ladder, or ramp shall be used as a means of \_\_\_\_\_ in trench excavations that are four (4') feet or more in depth.

16. The ladder(s), stairway(s), or ramp shall be spaced so that no employee in the trench excavation is more than twenty (25') feet from a \_\_\_\_\_.

17. When ladder(s) are employed, the top of the ladder shall extend a minimum of three (3') feet above the ground and shall be \_\_\_\_\_.

18. When \_\_\_\_\_ are exposed to vehicular traffic, each employee shall wear a warning vest made with reflective material or high visibility material.

#### **Excavation Chapter Post Quiz Answers**

1. Identifying, 2. Knowledgeable, 3. Performs, 4. Inspection(s) or Inspect, 5. Inspection(s) or Inspect, 6. Knowledge, 7. Determine(s), 8. Maintain(s), 9. Maintain(s), 10. Monitor, 11. Determine(d), 12. Precautions, 13. Employees, 14. Excavation(s), 15. Access or egress, 16. Means of egress, 17. Properly secured, 18. Excavation(s)

# Math Conversion Factors

1 PSI = 2.31 Feet of Water  
 1 Foot of Water = .433 PSI  
 1.13 Feet of Water = 1 Inch of Mercury  
 454 Grams = 1 Pound  
 2.54 CM = Inch  
 1 Gallon of Water = 8.34 Pounds  
 1 mg/L = 1 PPM  
 17.1 mg/L = 1 Grain/Gallon  
 1% = 10,000 mg/L  
 694 Gallons per Minute = MGD  
 1.55 Cubic Feet per Second = 1 MGD  
 60 Seconds = 1 Minute  
 1440 Minutes = 1 Day  
 .746 kW = 1 Horsepower

## LENGTH

12 Inches = 1 Foot  
 3 Feet = 1 Yard  
 5280 Feet = 1 Mile

## AREA

144 Square Inches = 1 Square Foot  
 43,560 Square Feet = 1 Acre

## VOLUME

1000 Milliliters = 1 Liter  
 3.785 Liters = 1 Gallon  
 231 Cubic Inches = 1 Gallon  
 7.48 Gallons = 1 Cubic Foot of water  
 62.38 Pounds = 1 Cubic Foot of water

## Dimensions

**SQUARE:** Area (sq.ft.) = Length X Width  
 Volume (cu.ft.) = Length (ft) X Width (ft) X Height (ft)

**CIRCLE:** Area (sq.ft.) = 3.14 X Radius (ft) X Radius (ft)

**CYLINDER:** Volume (Cu. ft) = 3.14 X Radius (ft) X Radius (ft) X Depth (ft)

**PIPE VOLUME:** .785 X Diameter <sup>2</sup> X Length = ? To obtain gallons multiply by 7.48

**SPHERE:**  $\frac{(3.14) (\text{Diameter})^3}{(6)}$  Circumference = 3.14 X Diameter

## General Conversions

### Flowrate

Multiply	→	to get
to get	←	Divide
cc/min	1	mL/min
cfm (ft <sup>3</sup> /min)	28.31	L/min
cfm (ft <sup>3</sup> /min)	1.699	m <sup>3</sup> /hr
cfh (ft <sup>3</sup> /hr)	472	mL/min
cfh (ft <sup>3</sup> /hr)	0.125	GPM
GPH	63.1	mL/min
GPH	0.134	cfh
GPM	0.227	m <sup>3</sup> /hr
GPM	3.785	L/min
oz/min	29.57	mL/min

**POUNDS PER DAY** = Concentration (mg/L) X Flow (MG) X 8.34

**A.K.A. Solids Applied Formula** = Flow X Dose X 8.34

$$\text{PERCENT EFFICIENCY} = \frac{\text{In} - \text{Out}}{\text{In}} \times 100$$

$$\begin{aligned} \text{TEMPERATURE: } \quad {}^{\circ}\text{F} &= ({}^{\circ}\text{C} \times 9/5) + 32 & 9/5 &= 1.8 \\ {}^{\circ}\text{C} &= ({}^{\circ}\text{F} - 32) \times 5/9 & 5/9 &= .555 \end{aligned}$$

$$\text{CONCENTRATION: Conc. (A) X Volume (A) = Conc. (B) X Volume (B)}$$

$$\text{FLOW RATE (Q): } Q = A \times V \text{ (Quantity = Area X Velocity)}$$

$$\text{FLOW RATE (gpm): Flow Rate (gpm) = } \frac{2.83 (\text{Diameter, in})^2 (\text{Distance, in})}{\text{Height, in}}$$

$$\% \text{ SLOPE} = \frac{\text{Rise (feet)}}{\text{Run (feet)}} \times 100$$

$$\text{ACTUAL LEAKAGE} = \frac{\text{Leak Rate (GPD)}}{\text{Length (mi.) X Diameter (in)}}$$

$$\text{VELOCITY} = \frac{\text{Distance (ft)}}{\text{Time (Sec)}}$$

**N** = Manning's Coefficient of Roughness

**R** = Hydraulic Radius (ft.)

**S** = Slope of Sewer (ft/ft.)

$$\text{HYDRAULIC RADIUS (ft)} = \frac{\text{Cross Sectional Area of Flow (ft)}}{\text{Wetted pipe Perimeter (ft)}}$$

$$\text{WATER HORSEPOWER} = \frac{\text{Flow (gpm)} \times \text{Head (ft)}}{3960}$$

$$\text{BRAKE HORSEPOWER} = \frac{\text{Flow (gpm)} \times \text{Head (ft)}}{3960 \times \text{Pump Efficiency}}$$

$$\text{MOTOR HORSEPOWER} = \frac{\text{Flow (gpm)} \times \text{Head (ft)}}{3960 \times \text{Pump Eff.} \times \text{Motor Eff.}}$$

$$\text{MEAN OR AVERAGE} = \frac{\text{Sum of the Values}}{\text{Number of Values}}$$

$$\text{TOTAL HEAD (ft)} = \text{Suction Lift (ft)} \times \text{Discharge Head (ft)}$$

$$\text{SURFACE LOADING RATE} = \frac{\text{Flow Rate (gpm)}}{\text{Surface Area (sq. ft)}} \text{ (gal/min/sq.ft)}$$

$$\text{MIXTURE STRENGTH (\%)} = \frac{(\text{Volume 1, gal}) (\text{Strength 1, \%}) + (\text{Volume 2, gal}) (\text{Strength 2, \%})}{(\text{Volume 1, gal}) + (\text{Volume 2, gal})}$$

$$\text{INJURY FREQUENCY RATE} = \frac{(\text{Number of Injuries}) \times 1,000,000}{\text{Number of hours worked per year}}$$

$$\text{DETENTION TIME (hrs)} = \frac{\text{Volume of Basin (gals)} \times 24 \text{ hrs}}{\text{Flow (GPD)}}$$

$$\text{SLOPE} = \frac{\text{Rise (ft)}}{\text{Run (ft)}}$$

$$\text{SLOPE (\%)} = \frac{\text{Rise (ft)} \times 100}{\text{Run (ft)}}$$

**POPULATION EQUIVALENT (PE):**

- 1 PE = .17 Pounds of BOD per Day
- 1 PE = .20 Pounds of Solids per Day
- 1 PE = 100 Gallons per Day

$$\text{LEAKAGE (GPD/inch)} = \frac{\text{Leakage of Water per Day (GPD)}}{\text{Sewer Diameter (inch)}}$$

$$\text{CHLORINE DEMAND (mg/L)} = \text{Chlorine Dose (mg/L)} - \text{Chlorine Residual (mg/L)}$$

**MANNING FORMULA**

$\tau Q$  = Allowable time for decrease in pressure from 3.5 PSI to 2.5 PSI

$\tau q$  = As below

$$\tau Q = (0.022) (d_1^2 L_1) / Q \quad \tau q = \frac{[0.085] [(d_1^2 L_1)]}{q}$$

Q = 2.0 cfm air loss

$\theta$  = .0030 cfm air loss per square foot of internal pipe surface

$\delta$  = Pipe diameter (inches)

L = Pipe Length (feet)

$$V = \frac{1.486 R^{2/3} S^{1/2}}{v}$$

V = Velocity (ft./sec.)

v = Pipe Roughness

R = Hydraulic Radius (ft)

S = Slope (ft/ft)

$$\text{HYDRAULIC RADIUS (ft)} = \frac{\text{Flow Area (ft.}^2\text{)}}{\text{Wetted Perimeter (ft.)}}$$

$$\text{WIDTH OF TRENCH (ft)} = \text{Base (ft)} + (2 \text{ Sides}) \times \frac{\text{Depth (ft}^2\text{)}}{\text{Slope}}$$

## Conversion Factors

1 acre = 43,560 square feet

1 cubic foot = 7.48 gallons

1 foot = 0.305 meters

1 gallon = 3.785 liters

1 gallon = 8.34 pounds

1 grain per gallon = 17.1 mg/L

1 horsepower = 0.746 kilowatts

1 million gallons per day = 694.45 gallons per minute

1 pound = 0.454 kilograms

1 pound per square inch = 2.31 feet of water

1% = 10,000 mg/L

Degrees Celsius = (Degrees Fahrenheit - 32) (5/9)

Degrees Fahrenheit = (Degrees Celsius \* 9/5) + 32

64.7 grains = 1 cubic foot

1,000 meters = 1 kilometer

1,000 grams = 1 kilogram

## Formula/Conversion Table

$$\text{Acid Feed Rate} = \frac{(\text{Waste Flow}) (\text{Waste Normality})}{\text{Acid Normality}}$$

$$\text{Alkalinity} = \frac{(\text{mL of Titrant}) (\text{Acid Normality}) (50,000)}{\text{mL of Sample}}$$

$$\text{Amperage} = \text{Voltage} \div \text{Ohms}$$

$$\text{Area of Circle} = (0.785)(\text{Diameter}^2) \text{ OR } (\pi)(\text{Radius}^2)$$

$$\text{Area of Rectangle} = (\text{Length})(\text{Width})$$

$$\text{Area of Triangle} = \frac{(\text{Base}) (\text{Height})}{2}$$

$$\text{C Factor Slope} = \text{Energy loss, ft.} \div \text{Distance, ft.}$$

$$\text{C Factor Calculation} = \text{Flow, GPM} \div [193.75 (\text{Diameter, ft.})^{2.63}(\text{Slope})^{0.54}]$$

$$\text{Chemical Feed Pump Setting, \% Stroke} = \frac{(\text{Desired Flow}) (100\%)}{\text{Maximum Flow}}$$

$$\text{Chemical Feed Pump Setting, mL/min} = \frac{(\text{Flow, MGD}) (\text{Dose, mg/L}) (3.785\text{L/gal}) (1,000,000 \text{ gal/MG})}{(\text{Liquid, mg/mL}) (24 \text{ hr. / day}) (60 \text{ min/hr.})}$$

$$\text{Chlorine Demand (mg/L)} = \text{Chlorine dose (mg/L)} - \text{Chlorine residual (mg/L)}$$

$$\text{Circumference of Circle} = (3.141) (\text{Diameter})$$

$$\text{Composite Sample Single Portion} = \frac{(\text{Instantaneous Flow}) (\text{Total Sample Volume})}{(\text{Number of Portions}) (\text{Average Flow})}$$

$$\text{Detention Time} = \frac{\text{Volume}}{\text{Flow}}$$

$$\text{Digested Sludge Remaining, \%} = \frac{(\text{Raw Dry Solids}) (\text{Ash Solids}) (100\%)}{(\text{Digested Dry Solids}) (\text{Digested Ash Solids})}$$

$$\text{Discharge} = \frac{\text{Volume}}{\text{Time}}$$

$$\text{Dosage, lbs/day} = (\text{mg/L})(8.34)(\text{MGD})$$

Dry Polymer (lbs.) = (gal. of solution) (8.34 lbs/gal)(% polymer solution)

Efficiency, % =  $\frac{(\text{In} - \text{Out})}{\text{In}} (100\%)$

Feed rate, lbs/day =  $\frac{(\text{Dosage, mg/L}) (\text{Capacity, MGD}) (8.34 \text{ lbs/gals})}{(\text{Available fluoride ion}) (\text{Purity})}$

Feed rate, gal/min (Saturator) =  $\frac{(\text{Plant capacity, gal/min.}) (\text{Dosage, mg/L})}{18,000 \text{ mg/L}}$

Filter Backwash Rate =  $\frac{\text{Flow}}{\text{Filter Area}}$

Filter Yield, lbs/hr./sq. ft =  $\frac{(\text{Solids Loading, lbs/day}) (\text{Recovery, \%} / 100\%)}{(\text{Filter operation, hr./day}) (\text{Area, ft}^2)}$

Flow, cu. ft./sec. = (Area, Sq. Ft.)(Velocity, ft./sec.)

Gallons/Capita/Day =  $\frac{\text{Gallons / day}}{\text{Population}}$

Hardness =  $\frac{(\text{mL of Titrant}) (1,000)}{\text{mL of Sample}}$

Horsepower (brake) =  $\frac{(\text{Flow, gpm}) (\text{Head, ft})}{(3,960) (\text{Efficiency})}$

Horsepower (motor) =  $\frac{(\text{Flow, gpm}) (\text{Head, ft})}{(3960) (\text{Pump, Eff}) (\text{Motor, Eff})}$

Horsepower (water) =  $\frac{(\text{Flow, gpm}) (\text{Head, ft})}{(3960)}$

Hydraulic Loading Rate =  $\frac{\text{Flow}}{\text{Area}}$

Leakage (actual) = Leak rate (GPD) ÷ [Length (mi.) x Diameter (in.)]

Mean = Sum of values ÷ total number of values

Mean Cell Residence Time (MCRT) =  $\frac{\text{Suspended Solids in Aeration System, lbs}}{\text{SS Wasted, lbs / day} + \text{SS lost, lbs / day}}$



$$\text{Organic Loading Rate} = \frac{\text{Organic Load, lbs BOD / day}}{\text{Volume}}$$

$$\text{Oxygen Uptake} = \frac{\text{Oxygen Usage}}{\text{Time}}$$

$$\text{Pounds per day} = (\text{Flow, MGD}) (\text{Dose, mg/L}) (8.34)$$

$$\text{Population Equivalent} = \frac{(\text{Flow MGD}) (\text{BOD, mg/L}) (8.34 \text{ lbs / gal})}{\text{Lbs BOD / day / person}}$$

$$\text{RAS Suspended Solids, mg/l} = \frac{1,000,000}{\text{SVI}}$$

$$\text{RAS Flow, MGD} = \frac{(\text{Infl. Flow, MGD}) (\text{MLSS, mg/l})}{\text{RAS Susp. Sol., mg/l} - \text{MLSS, mg/l}}$$

$$\text{RAS Flow \%} = \frac{(\text{RAS Flow, MGD}) (100 \%)}{\text{Infl. Flow, MGD}}$$

$$\text{Reduction in Flow, \%} = \frac{(\text{Original Flow} - \text{Reduced Flow}) (100\%)}{\text{Original Flow}}$$

$$\text{Slope} = \frac{\text{Drop or Rise}}{\text{Run or Distance}}$$

$$\text{Sludge Age} = \frac{\text{Mixed Liquor Solids, lbs}}{\text{Primary Effluent Solids, lbs / day}}$$

$$\text{Sludge Index} = \frac{\% \text{ Settleable Solids}}{\% \text{ Suspended Solids}}$$

$$\text{Sludge Volume Index} = \frac{(\text{Settleable Solids, \%}) (10,000)}{\text{MLSS, mg/L}}$$

$$\text{Solids, mg/L} = \frac{(\text{Dry Solids, grams}) (1,000,000)}{\text{mL of Sample}}$$

$$\text{Solids Applied, lbs/day} = (\text{Flow, MGD})(\text{Concentration, mg/L})(8.34 \text{ lbs/gal})$$

$$\text{Solids Concentration} = \frac{\text{Weight}}{\text{Volume}}$$

$$\text{Solids Loading, lbs/day/sq. ft} = \frac{\text{Solids Applied, lbs / day}}{\text{Surface Area, sq. ft}}$$

$$\text{Surface Loading Rate} = \frac{\text{Flow}}{\text{Rate}}$$

$$\text{Total suspended solids (TSS), mg/L} = \frac{\text{(Dry weight, mg)}(1,000 \text{ mL/L})}{\text{(Sample vol., mL)}}$$

$$\text{Velocity} = \frac{\text{Flow}}{\text{Area}} \quad \text{O R} \quad \frac{\text{Distance}}{\text{Time}}$$

$$\text{Volatile Solids, \%} = \frac{\text{(Dry Solids - Ash Solids)} (100\%)}{\text{Dry Solids}}$$

$$\text{Volume of Cone} = (1/3)(0.785)(\text{Diameter}^2)(\text{Height})$$

$$\text{Volume of Cylinder} = (0.785)(\text{Diameter}^2)(\text{Height}) \text{ OR } (\pi)(r^2)(h)$$

$$\text{Volume of Rectangle} = (\text{Length})(\text{Width})(\text{Height})$$

$$\text{Volume of Sphere} = [(\pi)(\text{diameter}^3)] \div 6$$

$$\text{Waste Milliequivalent} = (\text{mL}) (\text{Normality})$$

$$\text{Waste Normality} = \frac{\text{(Titrant Volume)} (\text{Titrant Normality})}{\text{Sample Volume}}$$

$$\text{Weir Overflow Rate} = \frac{\text{Flow}}{\text{Weir Length}}$$

## References

TITLE	DATE	EPA Number	NTIS Number	ERIC Number
Introduction to the National Pretreatment Program:	Feb. 99	EPA-833-B-98-002		
Aluminum, Copper, And Nonferrous Metals Forming And Metal Powders Pretreatment Standards: A Guidance Manual	December 1989	800-B-89-001	PB91-145441	W119
CERCLA Site Discharges to POTWs Guidance Manual	August 1990	540-G-90-005	PB90-274531	W150
Control Authority Pretreatment Audit Checklist and Instructions	May 1992	-- -- --		
Control of Slug Loadings To POTWs: Guidance Manual	February 1991	21W-4001	-- --	
Environmental Regulations and Technology: The National Pretreatment Program	July 1986	625-10-86-005	PB90-246521	W350
Guidance for Conducting a Pretreatment Compliance Inspection	September 1991	300-R-92-009	PB94-120631	W273
Guidance For Developing Control Authority Enforcement Response Plans	September 1989	--	PB90-185083/AS	--
Guidance for Reporting and Evaluating POTW Noncompliance with Pretreatment Implementation Requirements	September 1987	--	PB95-157764	W304
Guidance Manual For Battery Manufacturing Pretreatment Standards	August 1987	440-1-87-014	PB92-117951	W195
Guidance Manual for Electroplating and Metal Finishing Pretreatment Standard	February 1984	440-1-84-091-G	PB87-192597	W118
Guidance Manual For Implementing Total Toxic Organics (TTO) Pretreatment Standards	September 1985	440-1-85-009-T	PB93-167005	W339
Guidance Manual For Iron And Steel Manufacturing Pretreatment Standards	September 1985	821-B-85-001	PB92-114388	W103
Guidance Manual for Leather Tanning and Finishing Pretreatment Standards	September 1986	800-R-86-001	PB92-232024	W117
Guidance Manual for POTW Pretreatment Program Development	October 1983	--	PB93-186112	W639
Guidance Manual for POTWs to Calculate the Economic Benefit of Noncompliance	September 1990	833-B-93-007	-- --	
Guidance Manual for Preparation and Review of Removal Credit Applications	July 1985	833-B-85-200	-- --	
Guidance Manual for Preventing Interference at POTWs	September 1987	833-B-87-201	PB92-117969	W106
Guidance Manual for Pulp, Paper, and Paperboard and Builders' Paper and Board Mills Pretreatment Standards	July 1984	--	PB92-231638	W196
Guidance Manual for the Identification of Hazardous Wastes Delivered to Publicly Owned Treatment Works by Truck, Rail, or Dedicated Pipe	June 1987	--	PB92-149251	W202
Guidance Manual for the Use of Production-Based Pretreatment Standards and the Combined Wastestream Formula	September 1985	833-B-85-201	PB92-232024	U095
Guidance Manual on the Development and Implementation of Local Discharge Limitations Under the Pretreatment Program	December 1987	833-B-87-202	PB92-129188	W107
Guidance on Evaluation, Resolution, and Documentation of Analytical Problems Associated with Compliance Monitoring	June 1993	821-B-93-001	-- --	
Guidance to Protect POTW Workers From Toxic And Reactive Gases And Vapors	June 1992	812-B-92-001	PB92-173236	W115
Guides to Pollution Prevention: Municipal Pretreatment Programs	October 1993	625-R-93-006	-- --	
Industrial User Inspection and Sampling Manual For POTWs	April 1994	831-B-94-001	PB94-170271	W305

Industrial User Permitting Guidance Manual September 1989 833-B-89-001 PB92-123017 W109

Model Pretreatment Ordinance June 1992 833-B-92-003 PB93-122414 W108

Multijurisdictional Pretreatment Programs: Guidance Manual June 1994 833-B-94-005 PB94-203544 W607

National Pretreatment Program: Report to Congress July 1991 21-W-4004 PB91-228726 W694

NPDES Compliance Inspection Manual September 1994 300-B-94-014 -- --

POTW Sludge Sampling and Analysis Guidance Document August 1989 833-B-89-100 -- --

Prelim User's Guide, Documentation for the EPA Computer Program/Model for Developing Local Limits for Industrial Pretreatment Programs at Publicly Owned Treatment Works, Version 5.0 January 1997 -- -- --

Pretreatment Compliance Inspection and Audit Manual For Approval Authorities July 1986 833-B-86-100 PB90-183625 W277

Pretreatment Compliance Monitoring and Enforcement Guidance and Software (Version 3.0) (Manual) September 1986 (Software) September 1992 (Software) 831-F-92-001 (Software) PB94-118577 (Software) W269

Procedures Manual for Reviewing a POTW Pretreatment Program Submission October 1983 833-B-83-200 PB93-209880 W137

RCRA Information on Hazardous Wastes for Publicly Owned Treatment Works September 1985 833-B-85-202 PB92-114396 W351

Report to Congress on the Discharge of Hazardous Wastes to Publicly Owned Treatment Works February 1986 530-SW-86-004 PB86-184017 & PB95-157228 W922 & W692

Supplemental Manual On the Development And Implementation of Local Discharge Limitations Under The Pretreatment Program: Residential and Commercial Toxic Pollutant Loadings And POTW Removal Efficiency Estimation May 1991 21W-4002 PB93-209872 W113

The Nalco Water Handbook, ed. Frank N. Kemmer (New York: McGraw-Hill Book Company, 1988), pp. 35.1.

1996 Clean Water Needs Survey Report to Congress: Assessment of Needs for Publicly Owned Wastewater Treatment Facilities, Correction of Combined Sewer Overflows, and Management of Stormwater and Nonpoint Source Pollution in the United States.

## ***Other Guidance Documents that can help you***

Guidance Manual For Implementing Total Toxic Organics (TTO) Pretreatment Standards

Guidance Manual for Preparation and Review of Removal Credit Applications

Guidance Manual for Preventing Interference at POTWs

Guidance Manual for the Identification of Hazardous Wastes Delivered to Publicly Owned Treatment Works by Truck, Rail, or Dedicated Pipe

Guidance Manual for the Use of Production-Based Pretreatment Standards and the Combined Wastestream Formula

Guidance Manual on the Development and Implementation of Local Discharge Limitations Under the Pretreatment Program

Guidance to Protect POTW Workers From Toxic And Reactive Gases And Vapors

Prelim User's Guide, Documentation for the EPA Computer Program/Model for Developing Local Limits for Industrial Pretreatment Programs at Publicly Owned Treatment Works

Supplemental Manual On the Development And Implementation of Local

Discharge Limitations Under The Pretreatment Program: Residential and Commercial

Toxic Pollutant Loadings And POTW Removal Efficiency Estimation

CERCLA Site Discharges to POTWs Guidance Manual

Control of Slug Loadings To POTWs: Guidance Manual

Guidance For Developing Control Authority Enforcement Response Plans

Guidance Manual for POTWs to Calculate the Economic Benefit of Noncompliance

Industrial User Inspection and Sampling Manual For POTWs

Industrial User Permitting Guidance Manual

Model Pretreatment Ordinance

Multijurisdictional Pretreatment Programs: Guidance Manual

NPDES Compliance Inspection Manual

POTW Sludge Sampling and Analysis Guidance Document

Pretreatment Compliance Monitoring and Enforcement Guidance

RCRA Information on Hazardous Wastes for Publicly Owned Treatment Works

U.S. EPA Pretreatment Compliance Monitoring and Enforcement

## Acknowledgements

The principle authors of this document, titled "Nutrient Control Design Manual: State of Technology Review Report," were:

The Cadmus Group, Inc.

Dr. Clifford Randall, Professor Emeritus of Civil and Environmental Engineering at Virginia Tech and Director of the Occoquan Watershed Monitoring Program

Dr. James Barnard, Global Practice and Technology Leader at Black & Veatch

Jeanette Brown, Executive Director of the Stamford Water Pollution Control Authority and Adjunct Professor of Environmental Engineering at Manhattan College

Dr. H. David Stensel, Professor of Civil and Environmental Engineering at the University of Washington

### **EPA technical reviews of the document were performed by:**

*EPA Office of Research and Development*

Donald Brown

George Moore

Douglas Grosse

Richard Brenner

James Smith

Marc Mills

Dan Murray

*EPA Headquarters*

Donald Anderson

Phil Zahreddine

James Wheeler

*EPA Regions*

David Pincumbe, Region 1

Roger Janson, Region 1

Dave Ragsdale, Region 10, Office of Water and Watersheds

*Nutrient Control Design Manual: xiii January 2009*

*State of Technology Review Report*

### **External technical reviews of the document were performed by**

Dale E. Kocarek, Ohio Water Environment Association

Y. Jeffrey Yang, USEPA Office of Research and Development

### **Diagrams for illustration of specific concepts were provided by:**

Dr. James Barnard, Black and Veatch

Dr. H. David Stensel, University of Washington

## Bibliography

- Ahmed, Z., B. Lim, J. Cho, K. Song, K. Kim, and K. Ahn. 2007. Biological Nitrogen and Phosphorus Removal and Changes in Microbial Community Structure in a Membrane Bioreactor: Effect of Different Carbon Sources. *Water Research*. 42(1-2): 198-210.
- Alexander, R.B., R.A. Smith, G.E. Schwarz, E.W. Boyer, J.V. Nolan, and J.W. Brakebill. 2008. Differences in Phosphorus and Nitrogen Delivery to the Gulf of Mexico from the Mississippi River Basin. *Environmental Science and Technology*. 42(3): 822-830. Available online: [http://water.usgs.gov/nawqa/sparrow/gulf\\_findings](http://water.usgs.gov/nawqa/sparrow/gulf_findings).
- American Public Health Association (APHA), AWWA, and Water Environment Federation (WEF). 1998. *Standard Methods for the Examination of Water and Wastewater*. 20th Edition. 220 pp. Washington, D.C.: APHA, AWWA, and WEF.
- Anderson, J.L., and D.M. Gustafson. 1998. *Residential Cluster Development: Alternative Wastewater Treatment Systems*. MI-07059.
- ATV-DVWK. 2000. ATV-DVWK-Regelwerk, Arbeitsblatt ATV-DVWK-A131. Bemessung von einstufigen Belebungsanlagen. ATV-DVWK Standard A131: Design of Biological Wastewater Treatment Plants. In: Deutsche Vereinigung für Wasserwirtschaft Abwasser und Abfall e.V. (Eds.), GFAGesellschaft zur Förderung der Abwassertechnik. Hennef, Germany, ISBN 3-933707-41-2. <http://www.gfa-verlag.de>.
- Barker, P.S. and P.L. Dold. 1997. General Model for Biological Nutrient Removal Activated Sludge Systems: Model Presentation. *Water Environment Research*. 69(5): 969-999.
- Barnard, J.L. 1975. Biological Nutrient Removal without the Addition of Chemicals. *Water Research*. 9: 485-490.
- Barnard, J.L. 1984. Activated Primary Tanks for Phosphate Removal. *Water SA*. 10(3): 121-126.
- Barnard, J.L. 2006. Biological Nutrient Removal: Where We Have Been, Where We are Going? In *Proceedings of the Water Environment Federation, WEFTEC 2006*.
- Baronti, C., R. Curini, G. D'Ascenzo, A. Di Corcia, A. Gentili, and R. Samperi. 2000. Monitoring Natural and Synthetic Estrogens at Activated Sludge Sewage Treatment Plants and in a Receiving River Water. *Environmental Science and Technology*. 34(24): 5059-5066.
- Batt, A. L., S. Kim, and D.S. Aga. 2006. Enhanced Biodegradation of Iopromide and Trimethoprim in Nitrifying Activated Sludge. *Environmental Science and Technology*. 40(23): 7367-7373.
- Block, T.J., L. Rogacki, C. Voigt, D.G. Esping, D.S. Parker, J.R. Bratby, and J.A. Gruman. 2008. No Chemicals Required: This Minnesota Plant Removes Phosphorus Using a Completely Biological Process. *Water Environment & Technology*. Alexandria, VA: WEF. 20(1): 42-47.
- Blue Water Technologies. 2008. Blue Pro Pilot Project Report: Phosphorus Removal from Wastewater Located at a Municipal Wastewater Treatment Plant in Florida. Blue Water Technologies, Inc. Hayden, Idaho.
- Bott, C.B., S. N. Murthy, T. T. Spano, and C.W. Randall. 2007. WERF Workshop on Nutrient Removal: How Low Can We Go and What is Stopping Us from Going Lower? Alexandria, VA: WERF.
- Braghetta, A. and B. Brownawell. 2002. Removal of Pharmaceuticals and Endocrine Disrupting Compounds through Advanced Wastewater Treatment Technologies. AWWA – Water Quality Technology Conference.
- Braghetta, A.H., T. Gillogly, M.W. Harza, B. Brownawell, and M. Benotti. 2002. Removal of Pharmaceuticals and Endocrine Disrupting Compounds through Advanced Wastewater Treatment Technologies. AWWA – Water Quality Technology Conference.
- Brdjanovic, D., M.C.M. van Loosdrecht, P. Versteeg, C.M. Hooijmans, G.J. Alaerts, and J.J. Heijnen. 2000.

Modeling COD, N and P Removal in a Full-scale WWTP Haarlem Waarderpolder. *Water Research*. 34(3):846–858.

Bricker, S., B. Longstaff, W. Dennison, A. Jones, K. Boicourt, C. Wicks, and J. Woerner. 2007. Effects of Nutrient Enrichment in the Nation's Estuaries: A Decade of Change. NOAA Coastal Ocean Program Decision Analysis Series No. 26. Silver Spring, MD: National Centers for Coastal Ocean Science. 328 pp.

Available online: <http://ccma.nos.noaa.gov/publications/eutrouupdate/>

Bucheli-Witschel, M. and T. Egli. 2001. Environmental fate and microbial degradation of aminopolycarboxylic acids. *FEMS Microbiology Reviews*. 25(1): 69-106.

Bufe, M. 2008. Getting Warm? Climate Change Concerns Prompt Utilities to Rethink Water Resources, Energy Use. State of the Industry. *Water Environment & Technology*. Alexandria, VA: WEF. 20(1): 29-32.

Buser, H.-R., T. Poiger, and M.D. Müller. 1999. Occurrence and Environmental Behavior of the Chiral Pharmaceutical Drug Ibuprofen in Surface Waters and in Wastewater. *Environmental Science and Technology*. 33(15): 2529–2535.

CCME. 2006. Review of the State of Knowledge of Municipal Effluent Science and Research: Review of Existing and Emerging Technologies, Review of Wastewater Treatment Best Management Practices.

Canadian Council of Ministers of the Environment. Report prepared by Hydromantis Inc., University of Waterloo Dept. of Civil Engineering.

Chesapeake Bay Program, 2008. Chesapeake Bay Program – A Watershed Partnership. Accessed July 1, 2008. Available online: <http://www.chesapeakebay.net/nutr1.htm>

Clara, M., N. Kreuzinger, B. Strenn, O. Gans, E. Martinez, and H. Kroiss. 2005a. The Solids Retention Time – A Suitable Design Parameter to Evaluate the Capacity of Wastewater Treatment Plants to Remove Micropollutants. *Water Research*. 39(1):97-106.

Clara, M., B. Strenn, O. Gans, E. Martinez, N. Kreuzinger, and H. Kroiss. 2005b. Removal of Selected Pharmaceuticals, Fragrances and Endocrine Disrupting Compounds in a Membrane Bioreactor and Conventional Wastewater Treatment Plant. *Water Research*. 39: 4797-4807.

Crites R. and G. Tchobanoglous. 1998. *Small and Decentralized Wastewater Management Systems*. New York, NY: McGraw Hill.

DeBarbadillo, C., J. Barnard, S. Tarallo, and M. Steichen. 2008. Got Carbon? Widespread biological nutrient removal is increasing the demand for supplemental sources. *Water Environment & Technology*. Alexandria, VA: WEF. 20(1): 49-53.

*State of Technology Review Report* DeCarolis, J., S. Adham, W.R. Pearce, Z. Hirani, S. Lacy, and R. Stephenson. 2008. The Bottom Line: Experts Evaluate the Costs of Municipal Membrane Bioreactors. *Water Environment & Technology*. Alexandria, VA: WEF. 20(1): 54-59.

Deksissa, T., G.S. Wyche-Moore, and W.W. Hare. 2007. American Water Resources Association. Occurrence, Fate and Transport of 17B-Estradiol and Testosterone in the Environment. Summer Specialty Conference. June 25-27, 2007. Vail, Colorado.

Desbrow, C., E.J. Routledge, G.C. Brighty, J.P. Sumpter, M. Waldock. 1998. Identification of Estrogenic Chemicals in Stw Effluent. (1998) 1. Chemical Fractionation and in Vitro Biological Screening. *Environmental Science and Technology*. 32 (11): 1549-1558.

Dolan, G. 2007 *Methanol Safe Handling. Proceedings from the 2nd External Carbon Source Workshop*. Washington, DC, December 2007.

Dold, P., I. Takács, Y. Mokhayeri, A. Nichols, J. Hinojosa, R. Riffat, C. Bott, W. Bailey, and S. Murthy. 2008. Denitrification with Carbon Addition—Kinetic Considerations. *Water Environment Research*. 80(5): 417-427. WEF.

Eberle, K.C. and T.J. Baldwin. 2008. A Winning Combination - Innovative MBR technologies and reclaimed water dispersal systems overcome challenges to wastewater treatment in North Carolina coastal areas. Meeting strict regulations, protecting nearby ecosystems, and appealing to residents. *Water Environment & Technology*. Alexandria, VA: WEF. 20 (2): 35-43.



EPA Region 10. 2007. Advanced Wastewater Treatment to Achieve Low Concentration of Phosphorus.

EPA Region 10. EPA 910-R-07-002.

Erdal, U.G., Z.K. Erdal, and C.W. Randall. 2002. Effect of Temperature on EBPR System Performance and Bacterial Community. In *Proceedings of WEFTEC 2002*.

Everest, W.R., K. L. Alexander, S.S. Deshmukh, M.V. Patel, J.L. Daugherty, and J.D. Herberg. 2003.

Emerging Contaminant Removal Using Reverse Osmosis for Indirect Potable Use. In *Proceedings of the IDA World Congress on Desalination and Water Reuse*. Paradise Island, Bahamas, 2003. New York, NY: International Desalination Association.

*Federal Water Pollution Control Act*. 33 U.S.C. §§ 1251-1387, October 18, 1972, as amended 1973-1983, 1987, 1988, 1990-1992, 1994, 1995 and 1996.

Federal Register. 2001. Nutrient Criteria Development; Notice of Ecoregional Nutrient Criteria. J. Charles Fox, Assistant Administrator, Office of Water. 66(6): 1671-1674. Available online: <http://www.epa.gov/fedrgstr/EPA-WATER/2001/January/Day-09/w569.htm>

Filipe, C.D.M., G.T. Daigger, and C.P. L. Grady Jr. 2001. pH As a Key Factor in the Competition Between Glycogen Accumulating Organisms and Phosphate Accumulating Organisms. *Water Environment Research*. Alexandria, VA: WEF. 73(2): 223-232.

Fuhs, G.W. and M. Chen. 1975. Microbiological Basis of Phosphate Removal in the Activated Sludge Process for the Treatment of Wastewater. *Microbial Ecology*. 2(2): 119-38.

Gernaey, K.V., M.C.M. VanLoosdracht, M. Henze, M. Lind, and S.B. Jorgensen. 2004. Activated Sludge Wastewater Treatment Plant Modeling and Simulation: State of the Art. *Environmental Modeling and Software*. 19: 763-783.

Goodbred, S. L., R. J. Gilliom, T. S. Gross, N. P. Denslow, W. L. Bryant, and T. R. Schoeb. 1997. Reconnaissance of 17\_ -Estradiol, 11-Ketotestosterone, Vitellogenin, and Gonad Histopathology in Common Carp of United States Streams: Potential for Contaminant-Induced Endocrine Disruption. Denver, CO: USGS.

Gujer, W. , M. Henze, T. Mino, and M.C.M. van Loostrecht. 1999. Activated Sludge Model No. 3. *Water Science and Technology*. 39(1):183-193

Grohmann, K., E. Gilbert and S. H. Eberle. 1998. Identification of nitrogen-containing compounds of low molecular weight in effluents of biologically treated municipal wastewater. *Acta Hydrochimica Et Hydrobiologica* 26(1): 20-30.

Gross, C.M., J.A. Delgado, S.P. McKinney, H. Lal, H. Cover, and M.J. Shaffer. 2008. Nitrogen Trading Tool to Facilitate Water Quality Trading. *Journal of Soil and Water Conservation*. March/April 2008. 63(2): 44-45.

Gurr, C.J., M. Reinhard. 2006. Harnessing Natural Attenuation of Pharmaceuticals and Hormones in Rivers. *Environmental Science & Technology*. American Chemical Society. 40(8): 2872-2876.

Heberer, T. 2002a. Occurrence, Fate and Removal of Pharmaceutical Residues in the Aquatic Environment: A Review of Recent Research Data. *Toxicology Letters*. 131(1-2): 5-17.

Heinzle, E., I.J. Dunn, and G.B. Rhyner. 1993. Modeling and Control for Anaerobic Wastewater Treatment. *Advances in Biochemical Engineering and Biotechnology*. Vol. 48.

Henze, M., C.P.L. Grady, W. Gujer, G.v.R. Marais, and T. Matsuo. 1987. Activated Sludge Model No. 1. *IAWPRC Scientific and Technical Report No. 1*. London, UK. IWA

Henze, M., W. Gujer, T. Mino, T. Matsuo, M. Wentzel, and G.v.R. Marais. 1995. Activated Sludge Model No. 2. *IAWPRC Scientific and Technical Report No. 3*. London, UK. IWA

Henze, M., W. Gujer, T. Mino, T. Matsuo, M. Wentzel, G.v.R. Marais, and M.C.M. van Loostrecht. 1999.

Activated Sludge Model No. 2d: ASM2d. *Water Science and Technology*. 17(1):165-182

Hortskotte, G.A., D.G. Niles, D.S. Parker, and D. H. Caldwell. 1974. Full-scale testing of a water reclamation system. *Journal of the Water Pollution Control Federation*. 46(1): 181-197.

Jahan, K. 2003. *A Novel Membrane Process for Autotrophic Denitrification*. Alexandria, VA: WERF and IWA Publishing.

Jenkins, D.I. and W.F. Harper. 2003. *Use of Enhanced Biological Phosphorus Removal for Treating Nutrient-Deficient Wastewater*. Alexandria, VA: WERF and IWA Publishing.

Johnson, A. C., J.P. Sumpter. 2001. Removal of Endocrine-Disrupting Chemicals in Activated Sludge Treatment Works. *Environmental Science and Technology*. 35 (24): 4697-4703.

Joss, A., H. Andersen, T. Ternes, P.R. Richle, and H. Siegrist. 2004. Removal of Estrogens in Municipal Wastewater Treatment under Aerobic and Anaerobic Conditions: Consequences for Plant Optimization. *Environmental Science and Technology*. 38(11):3047-3055.

Kaiser, J. 1996. Scientists Angle for Answers. *Science*. 274 (December 13): 1837-1838.

*Nutrient Control Design Manual: 94 January 2009*

*State of Technology Review Report*

Kalogo, Y., and H. Monteith. 2008. State of Science Report: Energy and Resource Recovery from Sludge. Prepared for Global Water Research Coalition, by WERF, STOWA, and UK Water Industry Research Limited.

Katehis, D. 2007. Methanol, glycerol, ethanol, and others (Microc<sup>TM</sup>, Unicarb-DN, corn syrup, etc.) Including Suppliers, Costs, Chemical Physical Characteristics, and Advantages/Disadvantages. 2<sup>nd</sup> External Carbon Workshop. December 12-13, 2007. Sponsored by WERF, CWEA, VWEA, DC-WASA, MWCOG. Washington, D.C.

Khan, E., M. Awobamise, K. Jones, and S. Murthy. 2007. Development of Technology Based Biodegradable Dissolved Organic Nitrogen (BDON) Protocol. Presentation at the STAC-WERF Workshop:

Establishing a Research Agenda for Assessing the Bioavailability of Wastewater-Derived Organic Nitrogen in Treatment Systems and Receiving Waters. Baltimore, MD. September, 27-28, 2007.

Khunjar, W., C. Klein, J. Skotnicka-Pitak, T. Yi, N.G. Love, D. Aga, and W.F. Harper Jr. 2007. Biotransformation of Pharmaceuticals and Personal Care Products (PPCP) During Nitrification: The Role of Ammonia Oxidizing Bacteria versus Heterotrophic Bacteria.

Knocke, W.R., J.W. Nash, and C.W. Randall. 1992. Conditioning and Dewatering of Anaerobically Digested BPR Sludge. *Journal of Environmental Engineering*. 118(5): 642-656.

Kreuzinger, N., M. Clara, and H. Droiss. 2004. Relevance of the Sludge Retention Time (SRT) as Design Criteria for Wastewater Treatment Plants for the Removal of Endocrine Disruptors and Pharmaceuticals from Wastewater. *Water Science Technology*. 50(5): 149-156.

Landers, Jay. 2008. Halting Hypoxia. *Civil Engineering*. PP. 54-65. Reston, VA: ASCE Publications.

Long Island Sound Study. 2004. Protection+ Progress: Long Island Sound Study Biennial Report 2003–2004. Project Manager/Writer Robert Burg, NEIWPC/LISS. U.S. EPA Long Island Sound Office, Stamford Government Center. Stamford, CT. Available online: <http://www.longislandsoundstudy.net/pubs/reports/30350report.pdf>

Larsen, T.A., and J. Leinert, Editors. 2007. Novaquatis Final Report. *NoMix – A New Approach to Urban Water Management*. Switzerland: Eawag, Novaquatis.

Lombardo, P. 2008. Small Communities: Nutrient Management. *Water Environment & Technology*. Alexandria, VA: WEF. 20(1): 14-16.

Love, N. 2007. Maximizing the Dual Benefits of Advanced Wastewater Treatment Plant Processes: Reducing Nutrients and Emerging Contaminants: A Workshop Vision. University of Michigan. Department of Civil and Environmental Engineering.

Marttinen, S. K., R. H. Kettunen, and J.A. Rintala. 2003. Occurrence and removal of organic pollutants in sewages and landfill leachates. *The Science of the Total Environment*. 301(1-3): 1-12.

Mega, M., B.L., and R. Sykes. 1998. *Residential Cluster Development: Overview of Key Issues*. MI-07059.

Melcer, H., P.L. Dold, R.M. Jones, C.M. Bye, I. Takacs, H.D. Stensel, A.W. Wilson, P. Sun, and S. Bury. 2003. Methods for Wastewater Characterization in Activated Sludge Modeling. WERF Final Report. Project 99-WWF-3.

Munn, B., R. Ott, N. Hatala, and G. Hook. 2008. Tertiary Troubleshooting: Lessons Learned from the Startup of the Largest Tertiary Ballasted Settling System in the United States. *Water Environment & Technology*. Alexandria, VA: WEF. 20(3): 70 -75.

National Association of Clean Water Agencies. 2008. Letter to Ben Grumbles, Assistant Administrator for Water. February 29, 2008.

Neethling, J.B., B. Bakke, M. Benisch, A. Gu, H. Stephens, H.D. Stensel, and R. Moore. 2005. *Factors Influencing the Reliability of Enhanced Biological Phosphorus Removal*. Alexandria, VA: WERF and IWA Publishing.

Neethling, J.B., H.D. Stensel, C. Bott, and D. Clark. 2008. Limits of Technology and Research on Nutrient Removal. WERF Online Conference. October 8.

Nelson, D.J. and T.R. Renner. 2008. Nitrifying in the Cold: A Wisconsin facility experiments with IFAS to ensure nitrification in winter. *Water Environment & Technology*. Alexandria, VA: WEF. 20(4): 54-58.

Oberstar, J. 2008. Excerpt from Statement of The Honorable James Oberstar, May 12, 2008. *Impacts of Nutrients on Water Quality in the Great Lakes*. Presented before the House Subcommittee on Water Resources and the Environment field hearing. Port Huron, MI.

Oehmen, A., A.M. Sanders, M.T. Vives, Z. Yuan, and J. Keller. 2006. Competition between Phosphate and Glycogen Accumulating Organisms in Enhanced Biological Phosphorus Removal Systems with Acetate and Propionate Carbon Sources. *Journal of Biotechnology*. Elsevier Science BV. 123(1):22-32.

Oehmen, A., Z. Yuan, L.L. Blackall, and J. Keller. 2005. Comparison of Acetate and Propionate Uptake by Polyphosphate Accumulating Organisms and Glycogen Accumulating Organisms. *Biotechnology and Bioengineering*. 91(2). New York, NY: John Wiley & Sons, Inc.

Oppenheimer, J., R. Stephenson, A. Burbano, and L. Liu. 2007. Characterizing the Passage of Personal Care Products through Wastewater Treatment Processes. *Water Environment Research*. ProQuest Science Journals. 79(13): 2564-2577.

Pagilla, K. 2007. Organic Nitrogen in Wastewater Treatment Plant Effluents. Presentation at the STACWERF Workshop: Establishing a Research Agenda for Assessing the Bioavailability of Wastewater-Derived Organic Nitrogen in Treatment Systems and Receiving Waters, Baltimore, MD. September, 28, 2007.

Parkin, G. F. and P. L. McCarty. 1981. Production of Soluble Organic Nitrogen During Activated-Sludge Treatment Journal Water Pollution Control Federation. 53(1): 99-112.

Pearson, J.R., D.A. Dievert, D.J. Chelton, and M.T. Formica. 2008. Denitrification Takes a BAF: Starting up the first separate biological anoxic filter in Connecticut requires some problem-solving and know-how. *Water Environment & Technology*. Alexandria, VA: WEF. 20(5): 48-55.

Pehlivanoglu-Mantas, E. and D. L. Sedlak. 2004. Bioavailability of wastewater-derived organic nitrogen to the alga *Selenastrum capricornutum*. *Water Research* 38(14-15): 3189-3196.

Pehlivanoglu-Mantas, E. and D.L. Sedlak. 2006. Wastewater-Derived Dissolved Organic Nitrogen: Analytical Methods, Characterization, and Effects - A Review. *Critical Reviews in Environmental Science and Technology*. 36:261-285.

Poff, L.N., M. Brinson, and J. Day, Jr. 2002. Aquatic Ecosystems and Global Climate Change – Potential Impacts on Inland Freshwater and Coastal Wetland Ecosystems in the United States. Prepared for the Pew Center on Global Climate Change. January 2002.

Purdum, C. E., P.A. Hardiman, V.J. Bye, N.C. Eno, C.R. Tyler, J.P. Sumpter. 1994. Estrogenic Effects of Effluents from Sewage Treatment Works. 1994. *Chemistry and Ecology*. 8(4): 275-285.

Randall, C. W. and R. W. Chapin. 1997. Acetic Acid Inhibition of Biological Phosphorus Removal. *Water Environment Research*. 69(5):955-960.

Randall, C.W., H.D. Stensel, and J.L. Barnard. 1992. Design of activated sludge biological nutrient removal plants. In *Design and Retrofit of Wastewater Treatment Plants for Biological Nutrient Removal*. Lancaster, PA: Randall, Ed. Technomic Publishing Co. Inc. pp. 125-126.

Rauch, W., H. Alderink, P. Krebs, W. Schilling, and P. Vanrolleghem. 1998. Requirements for Integrated Wastewater Models Driving Receiving Water Objectives. IAWQ Conference, Vancouver.

Reardon, Roderick D. 2005. Tertiary Clarifier Design Concepts and Considerations. Presented at WEFTEC 2005.

Reiger, L., G. Koch, M. Kuhni, W. Gujer, and H. Seigrist. 2001. The EAWAG Bio-P Module for Activated Sludge Model No. 3. *Water Research*. 35(16): 3887-3903.

Robertson, L. A. and J. G. Kuenen. 1990. Combined Heterotrophic Nitrification and Aerobic Denitrification in *Thiosphaera pantotropha* and other Bacteria. *Antonie Van Leeuwenhoke*, vol. 56, pp. 289-299.

Rogalla, F., S. Tarallo, P. Scanlan, and C. Wallis-Lage. 2008. Sustainable Solutions: Much can be learned from recent work in Europe as well as the United States. *Water Environment & Technology*. Alexandria, VA: WEF. 20(4): 30-33.

Schilling, W., W. Bouwens, D. Barcharott, P. Krebs, W. Rauch, and P. VanRollegheem. 1997. Receiving Water Objectives – Scientific Arguments versus Urban Wastewater Management. In *Proceedings IAHR Congress*. San Francisco.

SCOPE. 2004. Newsletter No. 57. July. Centre Européen d'Etudes sur les Polyphosphates. Brussels, Belgium. Available online: <http://www.cepphosphates.org/Files/Newsletter/Scope%20Newsletter%2057%20Struvite%20conference.pdf>

Sedlak, D. 2007. The Chemistry of Organic Nitrogen in Wastewater Effluent: What It Is, What It Was, and What it Shall Be. Presentation at the STAC-WERF Workshop: Establishing a Research Agenda for Assessing the Bioavailability of Wastewater-Derived Organic Nitrogen in Treatment Systems and Receiving Waters. Baltimore, MD, September, 28, 2007.

Sen, D., S. Murthy, H. Phillips, V. Pattarkine, R.R. Copithorn, C.W. Randall, D. Schwinn, and S. Banerjee. 2008. Minimizing aerobic and post anoxic volume requirements in tertiary integrated fixed-film activated sludge (IFAS) and moving bed biofilm reactor (MBBR) systems using the aquifas model. Courtesy of WEFTEC 2008.

Sen, D. and C.W. Randall. 2008a. Improved Computational Model (AQUIFAS) for Activated Sludge, Integrated Fixed-Film Activated Sludge, and Moving-Bed Biofilm Reactor Systems, Part I: Semi-Empirical Model Development. *Water Environment Research*. Alexandria, VA: WEF. 80(5):439-453.

Sen, D. and C.W. Randall. 2008b. Improved Computational Model (AQUIFAS) for Activated Sludge, IFAS and MBBR Systems, Part II: Biofilm Diffusional Model. *Water Environment Research*. 80(7): 624-632.

Sen, D. and C.W. Randall. 2008c. Improved Computational Model (AQUIFAS) for Activated Sludge, IFAS and MBBR Systems, Part III: Analysis and Verification. *Water Environment Research*. 80(7): 633-645.

Shi, J., S. Fujisawa, S. Nakai, and M. Hosomi. 2004. Biodegradation of Natural and Synthetic Estrogen by Nitrifying Activated Sludge and Ammonia-oxidizing Bacterium *Nitromonas europaea*. *Water Research*. 38(9): 2323-2330.

Smith, S., I. Takács, S. Murthy, G.T. Daigger, and A. Szabó. Phosphate Complexation Model and Its Implications for Chemical Phosphorus Removal. 2008. *Water Environment Research*. 80(5): 428-438. Alexandria, VA: WEF.

Snyder, S. A., D.L. Villeneuve, E.M. Snyder, J.P. Giesy. 2001. Identification and Quantification of Estrogen Receptor Agonists in Wastewater Effluents. *Environmental Science and Technology*. 35(18): 3620-3625.

Snyder, S. A., P. Westerhoff, Y. Yoon, and D.L. Sedlak. 2003. Pharmaceuticals, Personal Care Products, and Endocrine Disruptors in Water: Implications for the Water Industry. *Environmental Engineering Science*. 20(5): 449-469.

Snyder, S.A., Y. Yoon, P. Westerhoff, B. Vanderford, R. Pearson, D. Rexing. 2003. Evaluation of Conventional and Advanced Drinking Water Treatment Processes to Remove Endocrine Disruptors and Pharmaceutically Active Compounds: Bench-Scale Results. In *Proceedings of the 3rd International Conference on Pharmaceuticals and Endocrine Disrupting Compounds in Water*. Minneapolis, MN: The National Ground Water Association. STAC-WERF. 2007. Workshop Considerations and Presentations. Establishing a Research Agenda for Assessing the Bioavailability of Wastewater-Derived Organic Nitrogen in Treatment Systems and Receiving Waters, Baltimore, MD, September, 28, 2007.

Stensel H.D. and T.E. Coleman 2000. Technology Assessments: Nitrogen Removal Using Oxidation Ditches. Water Environment Research Foundation. Alexandria, VA: WERF and IWA Publishing.

Stenstrom, M.K. and S.S. Song. 1991. Effects of Oxygen Transport Limitations on Nitrification in the

Activated Sludge Process. *Research Journal, Water Pollution Control Federation*, Vol. 63, p. 208.

Strom, P.F., H. X. Littleton, and G. Daigger. 2004. Characterizing Mechanisms of Simultaneous Biological Nutrient Removal During Wastewater Treatment. Alexandria, VA: WERF and IWA Publishing.

Strous, M., J. A. Fuerst, E. H. M. Kramer, S. Logemann, G. Muyzert, K. T. Van de Pas-Schoonen, R. Webb, J. G. Kuenen, and M.S. M. Jetten. 1999. Missing Lithotroph Identified as New Planctomycete. *Nature*. Vol. 400

Stumpf, M., T.A. Ternes, K. Haberer, and W. Baumann. 1998. Isolierung von Ibuprofen-Metaboliten und deren Bedeutung als Kontaminanten der aquatischen Umwelt. Isolation of Ibuprofen-Metabolites and their Importance as Pollutants of the Aquatic Environment. In *Fachgruppe Wasserchemie in der Gesellschaft Deutscher Chemiker*. Vom Wasser, Ed. VCH Verlagsgesellschaft mbH. Vol. 91: 291–303.

Sumpter, J. P. 1995. *Toxicology Letters*. Proceedings of the International Congress of Toxicology - VII, Washington State Convention and Trade Center Seattle, Washington, USA, Elsevier Ireland Ltd.

Szabó, A., I. Takács, S. Murthy, G.T. Daigger, I. Licskó, and S. Smith. 2008. Significance of Design and Operational Variables in Chemical Phosphorus Removal. *Water Environment Research*. 80(5):407-416. Alexandria, VA: WEF.

Tay, J. and X. Zhang. 2000. A fast Neural Fuzzy Model for High-rate Anaerobic Wastewater Treatment Systems. *Water Research*. Vol. 34(11).

Tchobanoglous, G., F. L. Burton, and H.D. Stensel. 2003. *Wastewater Engineering: Treatment and Reuse*. New York, NY: McGraw-Hill.

Ternes, T.A. 1998. Occurrence of drugs in German sewage treatment plants and rivers. *Water Research*. 32(11): 3245–3260.

Ternes, T.A., P. Kreckel, and J. Müller. 1999. Behaviour and Occurrence of Estrogens in Municipal Sewage Treatment Plants—II. Aerobic Batch Experiments with Activated Sludge. *The Science of the Total Environment*. 225(1–2): 91–99.

Tracy, K. D. and A. Flammino. 1987. Biochemistry and Energetics of Biological Phosphorus Removal. Proceeding, IAWPRC International Specialized Conference, Biological Phosphorus Removal from Wastewater. Rome, Italy. September 28-30. In *Biological Phosphorus Removal from Wastewater*. PP. 15-26. R. Ramadori, Ed. New York, NY: Pergamon Press.

Urgun-Demirtas, M., C. Sattayatewa, and K.R. Pagilla. 2007. Bioavailability Of Dissolved Organic Nitrogen In Treated Effluents. Proceedings from International Water Association/Water Environment Federation Nutrient Removal Conference, Baltimore, MD, March 2007.

USEPA. 1976. Process Design Manual for Phosphorus Removal. Great Lakes National Program Office.

GLNPO Library. EPA 625/1-76-001a. April 1976.

USEPA. 1987. Design Manual: Phosphorus Removal. Center for Environmental Research Information. Cincinnati, OH. EPA/625/1-87/001.

USEPA. 1987a. Handbook: Retrofitting POTWs for Phosphorus Removal in the Chesapeake Bay Drainage Basin. Center for Environmental Research Information. Cincinnati, OH. EPA/625/6-87/017.

USEPA. 1993. Nitrogen Control Manual. Office of Research and Development. EPA/625/R-93/010. September 1993.

USEPA. 1999. Decentralized Systems Technology Fact Sheet: Recirculating Sand Filters. USEPA, Office of Water. EPA 832-F-99-079. September, 1999.

USEPA. 1999a. Enhanced Coagulation and Enhanced Precipitative Softening Guidance Manual. Office of Water. EPA 815-R-99-012.

USEPA. 1999b. Wastewater Technology Fact Sheet: Fine Bubble Aeration. EPA 831-F-99-065. Available online: <http://epa.gov/OWM/mtb/mtbfact.htm>

USEPA. 1999c. Wastewater Technology Fact Sheet: Sequencing Batch Reactors. EPA 832-F-99-073. Available online: [http://www.epa.gov/owm/mtb/sbr\\_new.pdf](http://www.epa.gov/owm/mtb/sbr_new.pdf)

USEPA. 2000a. Wastewater Technology Fact Sheet: Trickling Filter Nitrification. EPA 832-F-00-015.

Available online: [http://www.epa.gov/owm/mtb/trickling\\_filt\\_nitrification.pdf](http://www.epa.gov/owm/mtb/trickling_filt_nitrification.pdf)  
 USEPA. 2000b. Wastewater Technology Fact Sheet: Ammonia Stripping. EPA 832-F-00-019. Available online: [http://www.epa.gov/owm/mtb/ammonia\\_stripping.pdf](http://www.epa.gov/owm/mtb/ammonia_stripping.pdf)  
 USEPA. 2000c. Wastewater Technology Fact Sheet: Oxidation Ditches. EPA 832-F-00-013. Available online: [http://www.epa.gov/owm/mtb/oxidation\\_ditch.pdf](http://www.epa.gov/owm/mtb/oxidation_ditch.pdf)  
 USEPA. 2000d. Wastewater Technology Fact Sheet: Chemical Precipitation. Office of Water. EPA 832-F-00-018.  
 USEPA 2000e. Wastewater Technology Fact Sheet Wetlands: Subsurface Flow. USEPA, Office of Water. EPA 832-F-00-023. September 2000.  
 USEPA. 2003. Wastewater Technology Fact Sheet: Ballasted Flocculation. Office of Waste Management. Municipal Technology Branch. EPA 832-F-03-010.  
 USEPA 2004. Local Limits Development Guidance. EPA 833-R-04-002A. Available online: [http://www.epa.gov/npdes/pubs/final\\_local\\_limits\\_guidance.pdf](http://www.epa.gov/npdes/pubs/final_local_limits_guidance.pdf)  
 USEPA. 2007. Biological Nutrient Removal Processes and Costs. U.S. Environmental Protection Agency Factsheet. EPA 823-R-07-002. June 2007.  
 USEPA. 2007a. Current Status of States & Territories Numeric Nutrient Criteria for Class of Waters Adopted Post-1997. Updated May 14, 2007. Available online: <http://www.epa.gov/waterscience/criteria/nutrient/strategy/status.html>  
 USEPA. 2007b. Memorandum from Benjamin Grumbles, Assistant Administrator for Water. Nutrient Pollution and Numeric Water Quality Standards. May 25, 2007. Available online: <http://www.epa.gov/waterscience/criteria/nutrient/files/policy20070525.pdf>  
 USEPA. 2007c. Wastewater Management Fact Sheet: Denitrifying Filters. EPA 832-F-07-014.  
 USEPA. 2007d. Wastewater Management Fact Sheet: Membrane Bioreactors. Available online: [http://www.epa.gov/owm/mtb/etfs\\_membrane-bioreactors.pdf](http://www.epa.gov/owm/mtb/etfs_membrane-bioreactors.pdf)  
 USEPA. 2007e. Wastewater Technology Fact Sheet: Side Stream Nutrient Removal. EPA 832-F-07-017.  
 USEPA. 2008a. Emerging Technologies for Wastewater Treatment and In-Plant Wet Weather Management. EPA 832-R-06-006. Available online: [http://www.epa.gov/OWOWM.html/mtb/emerging\\_technologies.pdf](http://www.epa.gov/OWOWM.html/mtb/emerging_technologies.pdf)  
 USEPA. 2008b. Mississippi River Basin & Gulf of Mexico Hypoxia. EPA Office of Wetlands, Oceans and Watersheds. Updated June 26, 2008. Available online: <http://www.epa.gov/msbasin/>  
 USEPA. 2008c. Onsite Wastewater Treatment Systems Technology Fact Sheet 2: Fixed Film Processes. EPA 625/R-00/008.  
 USEPA. 2008d. Onsite Wastewater Treatment Systems Technology Fact Sheet 3: Sequencing Batch Reactor Systems. EPA 625/R-00/008.  
 USEPA. 2008e. Onsite Wastewater Treatment Systems Technology Fact Sheet 8: Enhanced Nutrient Removal – Phosphorus. EPA 625/R-00/008.  
 USEPA. 2008f. Onsite Wastewater Treatment Systems Technology Fact Sheet 9 :Enhanced Nutrient Removal – Nitrogen. EPA 625/R-00/008.  
 USEPA. 2008g. Onsite Wastewater Treatment Systems Technology Fact Sheet 10: Intermittent Sand/Media Filters. EPA 625/R-00/008.  
 USEPA. 2008h. Onsite Wastewater Treatment Systems Technology Fact Sheet 11: Recirculating Sand/Media Filters. EPA 625/R-00/008.  
 U.S. Public Health Service and USEPA. 2008. Clean Watersheds Needs Surveys 2004 Report to Congress. Available online: <http://www.epa.gov/cwns/2004rtc/cwns2004rtc.pdf>  
 Vader, J., C. van Ginkel, F. Sperling, F. de Jong, W. de Boer, J. de Graaf, M. van der Most, and P.G.W. Stokman. 2000. Degradation of Ethinyl Estradiol by Nitrifying Activated Sludge. *Chemosphere*. 41 (8):1239-1243.  
 Vanderploeg, H. 2002. The Zebra Mussel Connection: Nuisance Algal Blooms, Lake Erie Anoxia, and other Water Quality Problems in the Great Lakes. 2002. Great Lake Environmental Research Laboratory. Ann Arbor, MI. Revised September 2002. Available online: <http://www.glerl.noaa.gov/pubs/brochures/mcystisflyer/mcystis.html>

Vanhooren, H., J. Meirlaen, V. Amerlink, F. Claeys, H. Vangheluwe, and P.A. Vanrolleghem. 2003. WEST Modelling Biological Wastewater Treatment. *Journal of Hydroinformatics*. London: IWA Publishing. 5(2003)27-50.

VanRollegghem, P.A. and D. Dochan. 1997. *Model Identification in Advanced Instrumentation, Data Interpretation, and Control of Biotechnological Processes*. Eds. J. Van Impe, P.A. VanRollegghem, and B. Igerentant. Netherlands: Kluwer Publishers.

VanRollegghem, P.A., W. Schilling, W. Rauch, P. Krebs, and H. Alderink. 1998. Setting up Campaigns for Integrated Wastewater Modeling. AWQ Conference: Applications of Models in Wastewater Management. Amsterdam.

Verma, M., S.K. Brar, J.F. Blais, R.D Tyagi, and R.Y. Surampalli. 2006. Aerobic Biofiltration Processes--- Advances in Wastewater Treatment. *Pract. Periodical of Haz., Toxic, and Radioactive Waste Mgmt.* 10:264-276.

Vethaak, A. D., J. Lahr, S.M. Schrap, A.C. Belfroid, G.B.J. Rijs, A. Gerritsen, J. de Boer, A.S. Bulder, G.C.M.

Grinwis, R.V. Kuiper. 2005. An Integrated Assessment of Estrogenic Contamination and Biological Effects in the Aquatic Environment of the Netherlands. *Chemosphere*. 59 (4): 511-524.

Wanner, O., H. Eberl, E. Morgenroth, D. Noguera, C. Picioreanu, B. Rittman, and M.V. Loosdrecht. 2006.

Mathematical Modeling of Biofilms. IWA Task Group on Biofilm Modeling. *Scientific and Technical Report 18*. London: IWA Publishing. Water and Wastewater News. 2008. Research Reveals Silver Nanoparticle Impact. May 6, 2008. Available online: <http://www.wwn-online.com/articles/62252>

WEF and ASCE. 1998. Design of Municipal Wastewater Treatment Plants - MOP 8, 4th Ed. Water Environment Federation and American Society of Civil Engineers. Alexandria, VA: WEF.

WEF and ASCE. 2006. Biological Nutrient Removal (BNR) Operation in Wastewater Treatment Plants - MOP 29. Water Environment Federation and the American Society of Civil Engineers. Alexandria, VA: WEF Press.

WEF. 2000. *Aerobic Fixed-Growth Reactors*, a special publication prepared by the Aerobic Fixed-Growth Reactor Task Force. WEF, Alexandria VA.

WEF. 2001. Natural Systems for Wastewater Treatment - MOP FD-16, 2nd Ed. Alexandria, VA: WEF.

WEF. 2005. *Membrane Systems for Wastewater Treatment*. Alexandria, VA: WEF Press.

WERF. 2000a. Technology Assessments: Nitrogen Removal Using Oxidation Ditches. Alexandria, VA, WERF.

WERF. 2000b. Investigation of Hybrid Systems for Enhanced Nutrient Control. Final Report, Collection and Treatment. Project 96-CTS-4. Alexandria, VA: WERF.

WERF. 2003a. A Novel Membrane Process for Autotrophic Denitrification. Alexandria, VA: WERF and IWA Publishing.

WERF. 2003b. Executive Summary: Methods for Wastewater Characterization in Activated Sludge Modeling. Alexandria, VA: WERF and IWA Publishing.

WERF. 2004. Preliminary Investigation of an Anaerobic Membrane Separation Process for Treatment of Low-Strength Wastewaters. Alexandria, VA: WERF and IWA Publishing.

WERF. 2004a. *Acclimation of Nitrifiers for Activated Sludge Treatment: A Bench-Scale Evaluation*. Alexandria, VA: WERF and IWA Publishing.

WERF. 2005. Technical Brief: Endocrine Disrupting Compounds and Implications for Wastewater Treatment. 04-WEM-6. Alexandria, VA: WERF and IWA Publishing.

WERF. 2005a. Nutrient Farming and Traditional Removal: An Economic Comparison. Alexandria, VA: WERF and IWA Publishing.

WERF. 2005b. Technical Approaches for Setting Site-Specific Nutrient Criteria. Alexandria, VA: WERF and IWA Publishing.

WERF. 2007. Nutrient Challenge Research Plan – 2007. October 31, 2007. Available online: <http://www.werfnutrientchallenge.com/>

WE&T. 2008a. Plant Profile: H.L. Mooney Water Reclamation Facility. *Water Environment & Technology*. Alexandria, VA: WEF. 20 (4): 70-71.

WE&T. 2008b. Problem Solvers: Enhanced Nutrient Removal Achieved. *Water Environment & Technology*. Alexandria, VA: WEF. 20(1): 85-86.

- WE&T. 2008c. Research Notes: Seeking to Destroy Hormone like Pollutants in Wastewater. *Water Environment & Technology*. Alexandria, VA: WEF. 20(4): 16.
- WE&T. 2008d. Research Notes: Study Examines Impacts of Membrane Residuals. *Water Environment & Technology*. Alexandria, VA: WEF. 20(2): 6-8.
- WE&T. 2008e. Small Communities: Distributed Wastewater Management, A practical, cost-effective, and sustainable approach to solving wastewater problems. *Water Environment & Technology*. Alexandria, VA: WEF. 20(2): 12-16.
- WE&T. 2008f. Waterline: Composting Toilets Serve Bronx Zoo Visitors. *Water Environment & Technology*. Alexandria, VA: WEF. 20(3): 35.
- Whang, L.M., C.D.M. Filipe, and J.K. Park. 2007. Model-based evaluation of competition between polyphosphate- and glycogen-accumulating organisms. *Water Research*. 41(6): 1312-1324.
- Wilson, T.E. and J. McGettigan. 2007. Biological Limitations: Chemical processes may be better at achieving strict effluent phosphorus limits. *Water Environment & Technology*. 19(6): 77-81. Alexandria, VA: WEF.
- Woods, N.C., S.M. Sock, and G.T. Daigger. 1999. Phosphorus Recovery Technology Modeling and Feasibility Evaluation for Municipal Wastewater Treatment Plants. *Environmental Technology*. 20(7): 663-679.
- Yi, T. and W. F. Harper. 2007. The Link between Nitrification and Biotransformation of 17 - Ethinylestradiol. *Environmental Science and Technology*. 41(12): 4311-4316.
- Zwiener, C., T.J. Gremm, and F.H. Frimmel. 2001. Pharmaceutical Residues in the Aquatic Environment and Their Significance for Drinking Water Production. In *Pharmaceuticals in the Environment*. Klaus, Kümmerer (Ed.). Springer, Berlin, Heidelberg New York, PP. 81–89. *State of Technology Review Report*





We welcome you to complete the assignment in Microsoft Word. You can easily find the assignment at [www.abctlc.com](http://www.abctlc.com).

Once complete, just simply fax or e-mail the answer key along with the registration page to us and allow two weeks for grading.

Once we grade it, we will e-mail a certificate of completion to you.

Call us if you need any help. If you need your certificate back within 48 hours, you may be asked to pay a rush service fee of \$50.00.

You can download the assignment in Microsoft Word from TLC's website under the Assignment Page. [www.abctlc.com](http://www.abctlc.com)

You will have 90 days in order to successfully complete this assignment with a score of 70% or better.

If you need any assistance, please contact TLC's Student Services. Once you are finished, please mail, e-mail or fax your answer sheet along with your registration form.